

# A Roadmap for Big Model \*

Sha Yuan<sup>\*1</sup> Hanyu Zhao<sup>\*1</sup> Shuai Zhao<sup>\*1</sup> Jiahong Leng<sup>\*1</sup> Yangxiao Liang<sup>\*1</sup> Xiaozhi Wang<sup>\*2</sup> Jifan Yu<sup>\*2</sup> Xin Lv<sup>\*2</sup> Zhou Shao<sup>\*1</sup> Jiaao He<sup>\*2</sup> Yankai Lin<sup>\*3</sup> Xu Han<sup>\*2</sup> Zhenghao Liu<sup>\*4</sup> Ning Ding<sup>\*2</sup> Yongming Rao<sup>\*2</sup> Yizhao Gao<sup>\*5</sup> Liang Zhang<sup>\*5</sup> Ming Ding<sup>\*2</sup> Cong Fang<sup>\*6</sup> Yisen Wang<sup>\*6</sup> Mingsheng Long<sup>\*2</sup> Jing Zhang<sup>\*5</sup> Yinpeng Dong<sup>\*2</sup> Tianyu Pang<sup>\*2</sup> Peng Cui<sup>\*2</sup> Lingxiao Huang<sup>\*7</sup> Zheng Liang<sup>\*2</sup> Huawei Shen<sup>\*8</sup> Hui Zhang<sup>\*2</sup> Quanshi Zhang<sup>\*9</sup> Qingxiu Dong<sup>\*6</sup> Zhixing Tan<sup>\*2</sup> Mingxuan Wang<sup>\*13</sup> Shuo Wang<sup>\*2</sup> Long Zhou<sup>\*14</sup> Haoran Li<sup>\*10</sup> Junwei Bao<sup>\*10</sup> Yingwei Pan<sup>\*10</sup> Weinan Zhang<sup>\*11</sup> Zhou Yu<sup>\*12</sup> Rui Yan<sup>\*5</sup> Chence Shi<sup>\*15</sup> Minghao Xu<sup>\*15</sup> Zuobai Zhang<sup>\*15</sup> Guoqiang Wang<sup>1</sup> Xiang Pan<sup>16</sup> Mengjie Li<sup>17</sup> Xiaoyu Chu<sup>1</sup> Zijun Yao<sup>2</sup> Fangwei Zhu<sup>2</sup> Shulin Cao<sup>2</sup> Weicheng Xue<sup>2</sup> Zixuan Ma<sup>2</sup> Zhengyan Zhang<sup>2</sup> Shengding Hu<sup>2</sup> Yujia Qin<sup>2</sup> Chaojun Xiao<sup>2</sup> Zheni Zeng<sup>2</sup> Ganqu Cui<sup>2</sup> Weize Chen<sup>2</sup> Weilin Zhao<sup>2</sup> Yuan Yao<sup>2</sup> Peng Li<sup>3</sup> Wenzhao Zheng<sup>2</sup> Wenliang Zhao<sup>2</sup> Ziyi Wang<sup>2</sup> Borui Zhang<sup>2</sup> Nanyi Fei<sup>5</sup> Anwen Hu<sup>5</sup> Zenan Ling<sup>6</sup> Haoyang Li<sup>5</sup> Boxi Cao<sup>18</sup> Xianpei Han<sup>18</sup> Weidong Zhan<sup>6</sup> Baobao Chang<sup>6</sup> Hao Sun<sup>2</sup> Jiawen Deng<sup>2</sup> Chujie Zheng<sup>2</sup> Juanzi Li<sup>⊠2</sup> Lei Hou<sup>⊠2</sup> Xigang Cao<sup>⊠1</sup> Jidong Zhai<sup>⊠2</sup> Zhiyuan Liu<sup>⊠2</sup> Maosong Sun<sup>⊠2</sup> Jiwen Lu<sup>⊠2</sup> Zhiwu Lu<sup>⊠5</sup> Qin Jin<sup>⊠5</sup> Ruihua Song<sup>5</sup> Ji-Rong Wen<sup>5</sup> Zhouchen Lin<sup>⊠6</sup> Liwei Wang<sup>⊠6</sup> Hang Su<sup>⊠2</sup> Jun Zhu<sup>⊠2</sup> Zhifang Sui<sup>⊠6</sup> Jiajun Zhang<sup>⊠19</sup> Yang Liu<sup>⊠2</sup> Xiaodong He<sup>⊠10</sup> Minlie Huang<sup>⊠2</sup> Jian Tang<sup>⊠15</sup> **Jie Tang**<sup>⊠2,1</sup>

<sup>1</sup> Beijing Academy of Artificial Intelligence

<sup>2</sup> Tsinghua University

<sup>3</sup> Wechat, Tencent Inc.

<sup>4</sup> Northeastern University

<sup>5</sup> Renmin University of China

<sup>6</sup> Peking University

<sup>7</sup> Huawei TCS Lab

<sup>8</sup> Institute of Computing Technology, Chinese Academy of Sciences

<sup>9</sup> Shanghai Jiao Tong University

<sup>10</sup> JD AI Research

<sup>11</sup> Harbin Institute of Technology

<sup>12</sup> Columbia University

<sup>13</sup> ByteDance AI Lab

<sup>14</sup> Microsoft Research Asia

<sup>15</sup> Mila-Quebec AI Institute & University of Montreal

<sup>16</sup> New York University

<sup>17</sup> BeiHang University

<sup>18</sup> Institute of Software, Chinese Academy of Sciences

<sup>19</sup> Institute of Automation Chinese Academy of Sciences

Jie Tang designs this big model roadmap. Authors labeled with  $\boxtimes$  organize different parts of this report. Authors labeled with \* contribute equally. They are ranked according to their section.

## Contents

1	Introduction . . . . .	4
1.1	Background . . . . .	4
1.2	Big Model Era . . . . .	5
1.3	Overview of This Paper . . . . .	7
2	Data . . . . .	9
2.1	Existing Corpora . . . . .	10
2.2	Corpora Construction . . . . .	12
2.3	Noteworthy Issues . . . . .	13
2.4	Future Directions . . . . .	15
3	Knowledge . . . . .	17
3.1	Knowledge Graphs and Knowledge Integration/Fusion . . . . .	17
3.2	Big Model-based Knowledge Acquisition . . . . .	20
3.3	Knowledge-enhanced Big Models . . . . .	22
4	Computing System . . . . .	25
4.1	Large Scale Intelligent Computing System (LSICS) . . . . .	25
4.2	Technical Details for LSICS . . . . .	27
4.3	Discussion on LSICS . . . . .	31
5	Parallel Training System . . . . .	32
5.1	Scope of Training System . . . . .	32
5.2	State-of-the-art Systems for Model Training . . . . .	33
5.3	Future Directions . . . . .	38
6	Big Language Model . . . . .	39
6.1	Neural Language Representation . . . . .	39
6.2	Language Modeling as Deep Learning Objectives . . . . .	41
6.3	Pre-Training-then-Fine-Tuning . . . . .	43
6.4	Typical Tasks . . . . .	47
6.5	Advanced Topics . . . . .	53
6.6	Future Directions . . . . .	58
7	Big Vision Models . . . . .	58
7.1	Architectures of Vision Model . . . . .	59
7.2	Pretraining Strategies . . . . .	61
7.3	Applications of Big Vision Models . . . . .	63
7.4	Future Directions . . . . .	64
8	Big Multi-modal Model . . . . .	66
8.1	Feature Representation . . . . .	66
8.2	Model Architecture . . . . .	68
8.3	Pre-training Tasks . . . . .	69
8.4	Downstream Tasks . . . . .	71
8.5	Challenges and Future Directions . . . . .	72
9	Theory and Interpretability . . . . .	73
9.1	Basic Theory of Big Model . . . . .	74
9.2	Existing studies of interpretability . . . . .	76
9.3	Future Directions . . . . .	77
10	Commonsense Reasoning . . . . .	79
10.1	What is Commonsense Reasoning? . . . . .	79
10.2	Can Big Models Know Commonsense? . . . . .	80
10.3	How to Enable Commonsense Reasoning? . . . . .	80
10.4	Resources and Benchmarks . . . . .	81
10.5	Challenges and Future Directions . . . . .	81
11	Reliability and Security . . . . .	82
11.1	Background . . . . .	83
11.2	Adversarial Vulnerability . . . . .	84
11.3	Data Poisoning . . . . .	86
11.4	Challenges and Future Directions . . . . .	89
12	Big Model Governance . . . . .	90
12.1	Background . . . . .	90
12.2	Overviewing and Analyzing Existing Works . . . . .	92
12.3	Open Problems and Future Directions . . . . .	95
13	Big Model Evaluation . . . . .	97
13.1	Existing Benchmarks and Corresponding Datasets . . . . .	97

13.2	Challenges of Performance Evaluation . . . . .	99
13.3	Challenges of Efficiency Evaluation . . . . .	100
13.4	Future Work on Performance Evaluation . . . . .	101
13.5	Future Work on Efficiency Evaluation . . . . .	103
14	Application in Machine Translation . . . . .	103
14.1	Background . . . . .	104
14.2	Applications of Big Model in Machine Translation . . . . .	104
14.3	Challenges and Future Directions . . . . .	114
15	Application in Text Generation . . . . .	115
15.1	Background . . . . .	115
15.2	Tasks for Text Generation . . . . .	116
15.3	Architectures for Text Generation . . . . .	118
15.4	Future Directions . . . . .	119
16	Application in Dialogue . . . . .	119
16.1	Background . . . . .	120
16.2	Big Dialogue Models . . . . .	120
16.3	Key Research Problems in Dialogue . . . . .	121
16.4	Novel Applications . . . . .	127
16.5	Challenges and Future Directions . . . . .	128
17	Application in Protein Research . . . . .	129
17.1	Background . . . . .	129
17.2	Current Progress . . . . .	131
17.3	Future Directions . . . . .	136
18	Conclusion . . . . .	137
18.1	The Significance of Big Models . . . . .	137
18.2	Several Directions of Future Work . . . . .	138

# 1 Introduction

## 1.1 Background

In this era of interdisciplinary science, many scientific achievements, especially in artificial intelligence (AI), have brought dramatic revolutions to human society. With the rapid development of AI, especially the emergence and rapid development of deep learning technology, AI has entered the stage of large-scale industrial application. The early research of AI mainly focused on learning algorithms, followed by deep learning architecture. The traditional machine learning models primarily relied on hand-crafted features and statistical methods. Deep learning models can automatically learn task-specific features from data [1]. Deep learning models, such as convolutional neural networks (CNNs) [2,3], recurrent neural networks (RNNs) [4,5], generative adversarial networks (GANs) [6,7], graph neural networks (GNNs) [8,9], have been widely applied in various AI tasks in recent years. Although deep learning has been successful in scientific research and industrial applications, the performance is limited in specific fields due to data-hungry. Training models need a large amount of labeled data to maintain good performance. Along with the deep learning researches, considerable efforts have been devoted to high-quality AI datasets construction [10,11]. However, the manual data labeling process is costly and time-consuming. The situation is made worse by the fact that the available data for specific tasks is limited. To reduce the work for dataset construction, we want to adapt a model trained on existing data to handle new specific tasks. How to achieve the transfer learning process is a critical research issue in the AI field.

The learning process for understanding, retention, application, and transfer forges the knowledge base of human beings. We humans can deal with new problems based on the previous learning basis. The fantastic learning process allows people to go from knowing almost nothing to being specific domain experts. Human behaviors inspire AI researches. Instead of training an AI model from scratch, transfer learning [12] suggests a two-stage solution to improve model generalization without much expensive data labeling efforts. The pre-training process captures knowledge from source tasks, and the fine-tuning process transfers the learned knowledge to target tasks. Knowledge obtained in the pre-training phase enables the fine-tuning process with limited data.

The transfer learning technique is first applied in the computer vision (CV) field, as there are already large-scale manually constructed image datasets such as ImageNet [10], which provide an ideal source for model pre-training. After absorbing a huge amount of visual knowledge through the pre-training process, models can perform well in many downstream tasks with adjustment on only a small number of task-related data. Under this circumstance, the trend of exploring CV field through big models (BMs) are triggered and spread to many specific tasks, including image classification [13], image caption [14], image segmentation [15] and object detection [16].

As the BM achieves success in the CV field, similar researches are conducted in natural language processing (NLP). However, a long-term problem has been challenging text processing since the rise of deep learning. Gradient vanishing and gradient explosion that can cause unexpected outputs occur commonly in deep networks used in NLP. Thus, initial research of BM in NLP focuses on shallow networks such as Word2Vec [17]. Nevertheless, shallow networks can not capture various semantic information of words and sentences. For example, a polysemous shows different meanings in different sentences, but shallow networks are hard to distinguish. Although networks like RNN are constructed to solve the above problem by involving context information, the depth remains a pain point. With the advent of transformer network structure, constructing deep network models in NLP field becomes feasible. After that, the pre-training technique achieves a series of breakthroughs in NLP. BMs including BERT [18] and T5 [19] are trained and obtain state-of-the-art performance in many downstream tasks.

The 175-billion-parameter GPT-3 performs well on several downstream NLP tasks, especially generation tasks. Enlarging parameter scale enables BMs to better capture linguistic knowledge contained in the training data. The study of GPT-3 demonstrates that scaling up models greatly improves task-agnostic, few-shot performance, sometimes even becoming competitive with prior state-of-the-art fine-tuning approaches [20]. The significant findings attended by GPT-3 model stimulate the research of large-scale BMs and related technologies. The parameter scale of BMs increases from billions to trillions rapidly and still keeps the steep upward trend. By enlarging model parameters consistently, researchers are trying to explore the performance improving limit of BMs.

Currently, the common pattern of realizing artificial intelligence is to construct models through the combination of data, computing power and algorithms. In recent years, the traditional model construction pattern “different models for different tasks” is gradually transformed to the new trend “one large-scale pre-trained model for various tasks”. In this new pattern, we also call large-scale pre-trained models as big models (BMs) for short. Researchers collect data as much as possible and design advanced algorithms, training big models based on large-scale computing system for users with different demands.

With the research of big models becoming the focus of artificial intelligence, it is possible that the big model leads the technological transition in the next few years and brings a new industrial pattern. More specifically, the new industrial pattern can be analogized to the electricity supply system. The big models play the basic role of “intelligence producer”, which can generate high-quality intelligence power under the support of large amount computing power and serve various AI applications. Through the development of big information model and big biomimetic model, the



research process in the fields of electronic information and biomedicine can be accelerated. Meanwhile, the development of big models can help those innovative enterprises and individual developers construct high-intelligence applications, thus promoting the intellectual update of real economy.

## 1.2 Big Model Era

There are several serious pain points in artificial intelligence research and development at deep learning stage. Firstly, the generalization of models is a common problem, which means the model trained under a specific application scenarios are not applicable in another. Training from scratch are needed when transferring between different fields, which leads to high model training cost. Secondly, the present model training is basically in a “hand-crafted” pattern, because adjusting and tuning parameters needs lots of manual work, requiring for a large number of AI professionals to participate in. Thirdly, the model training proposes high standards for data quality and large-scale labeled data are necessary. The lack of data in some fields restricts the application of AI technology.

Those problems mentioned above cause the high-cost and low-efficiency issues in AI development and application. The AI talent shortage and high research cost also make it harder for those small businesses to train task-specific models in their industrial scenarios. Therefore, the pattern of “self-training self-use” of tasks-specific models is contrast with the development trend of AI, becoming the hinder of widely usage of AI technology. Training big models can be one potential solution due to their strong generalization ability. Big models can be adopted into different tasks with slight fine-tuning or even without extra adjustment. In this situation, small businesses can conduct their AI researches by directly calling the big model interface, which can be completed with few algorithm professionals. Thus, the research cost of developing intelligent application is reduced in a great extent. From a conceptual perspective, Li et al. [21] point out that the application of foundation model makes the scheme of self-supervised learning and fine-tuning become the mainstream approach gradually, and brings the progress of the cognitive ability of intelligent agent. However, one hidden danger of foundation models is that any defects of them will also be inherited by all their downstream models, thus quickly covering the whole community of foundation models. The mentioned foundation model is known as the BMs, and it is called Big Model in the Chinese context. The upcoming subsections will introduce the big model’s characteristics, why it becomes a trend, and the technical challenges faced by the big model.

### 1.2.1 The Characteristics of Big Model

Generally, the big model is the production of combining big data, large-scale computing power and intelligent algorithms. Big models can absorb the laws contained in the data and become the carrier of intelligence. From the industrial perspective, the big model is the bridge connecting artificial intelligence technology and industrial ecology, driving the development of fundamental software and hardware and supporting various intelligent applications. From a technical point of view, a big model is a deep neural network with a large number of parameters pre-trained on large-scale non-labeled datasets. In general, big models can have better generality, adapting to tasks in different domains with few shot data fine-tuning or even without data adjustment. To help the model deal with domain-specific task, fine tuning on relatively small dataset in different domains are usually performed, and those specific tasks are referred to as downstream tasks. The use of big models greatly reduces the dependence of downstream tasks on large quantity of high quality data, thus some new scenes that facing problems with labeled data collection can be developed.

Given the context in which humanity has been trying to reproduce its general intelligence, the big model is one of the current research works showing the possession of this high-level intelligence realized by machines. Big models show the following features of general intelligence.

**Big-data Driven.** Compared with the domain-specific model, the amount of data required for training big models is much larger. For example, the NLP pre-training corpora usually tend to have more than 10 billion tokens (about terabyte level), which provides the richer resource of pattern learning. Generally, big-data training causes a substantial computational burden, thus presenting higher requirements for parallel computing software and hardware systems. Like human learning, people at the beginning of life will learn a wide range of data and knowledge to establish the initial worldview.

**Multi-tasks Adaptive.** Applications in different domains, such as dialogue generation and protein structure prediction, need to be pre-trained on different large-scale datasets in the domain before applying them to specific downstream tasks. However, it is worth noting that the big model performs well on several tasks simultaneously inside the same domain, such as natural language generation (NLG) and natural language understanding (NLU) tasks that belong to NLP. This multi-tasks adaptive feature indicates that big models have the potential of general intelligence. This feature is supported by a bunch of sophisticated technologies and well-designed pre-training tasks. The adaptation to multi-tasks is similar to how humans acquire a large amount of general knowledge in K12 and can choose multiple specialties in future undergraduate or research studies.

**Few-shot (Zero-shot).** Humans are very good at drawing inferences from one another, and if a model can achieve this, it implies a degree of intelligence. Big models exhibit the ability to adapt several downstream tasks after pre-training on big data, either triggered by a small group of labelled samples or even no trigger. This trigger generally refers to a prompt. That means big models have superiority in those specific fields where labelled data collection is restricted. Enlarging the scale of models tends to achieve further gains of machine intelligence. In the NLP area, BERT can encode rich semantic and syntactic information with a single representation, and usually, higher layers of networks encode semantic information [22] which traditional statistic word embedding can not. Besides, the parameter size from GPT-2 (1.5 billion) to GPT-3 (175 billion) is increased by a factor of 100, and GPT-3 can better achieve downstream task adaptation without fine-tuning, with some tasks achieving the same effect as fine-tuned model [20].

## 1.2.2 The Development of Big Models

Since the concept of deep learning was presented formally in 2006 [23], it has gradually become a research hot-spot in the field of artificial intelligence. The pre-training and fine-tuning paradigm [24], composed of unsupervised training for weight initialization and supervised fine-tuning, have gradually become the mainstream approach of model construction. It alleviates the poor generalization caused by the lack of labeled data and random initialization of weights. Initially, the pre-training model was adopted and stimulated performance improvement in the Computer Vision (CV) field. For example, the ImageNet dataset [10], which includes more than 14 million images, was used to pre-train models before being fine-tuned to downstream tasks such as image classification. With the consistent accumulation of Internet text data and the advent of Google’s milestone model architecture Transformer [25], the pre-training paradigm started to be used for NLP tasks. The representative pre-trained language models (PLMs) emerged, including Bert [18], GPT [26], T5 [19]. During this period, the concept of self-supervised learning in NLP gradually emerged, that is, using the statistics of context occurrence in a large number of corpus to complete model training. As shown in Fig. 1, since OpenAI launched the GPT model in June 2018, the scale of the Transformer-based language model increased, constantly exploring the upper limit of parameter scale in performance improvement. BAAI releases an even larger model, WuDao, with 1.75 trillion parameters. BaGuaLu [27] is able to train 174 trillion parameter models. Moreover, Transformer architecture breaks the boundary of NLP and has been proved to have the performance comparable to convolution neural network in several CV tasks [28, 29, 30]. In January 2021, OpenAI released both CLIP [31] model for text-image matching task and DALL-E model for text-to-image generation task [32], triggering the research in the field of large-scale multi-modal pre-training. Subsequently, big multi-modal models such as Cogview [33] and BriVL [34] were released by BAAI in the same year, as shown in Table 1.

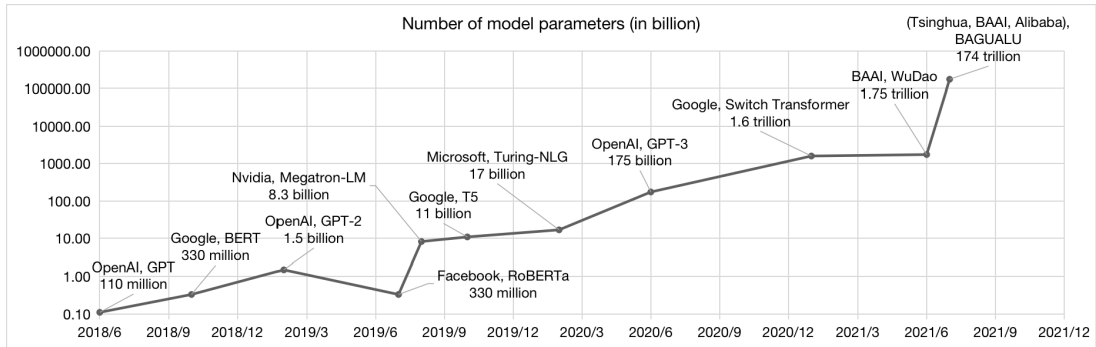

**Fig. 1.** The scale of BMs gradually increases

**Table 1.** List of important multi-modal BMs since June 2018

Released Time	Institution	Model Name	Parameter Scale
2021.1	OpenAI	CLIP	-
2021.1	OpenAI	DALL-E	12 billion
2021.3	BAAI	BriVL	1 billion
2021.6	BAAI	Cogview	4 billion
2021.6	BAAI	WuDao	1.75 trillion

### 1.3 Overview of This Paper

There is a lack of systematic analysis and practical discussion of the big models' technical challenges and future direction. In order to better promote the big model research, a roadmap that shows the training conditions, key technologies, and downstream application of big models is necessary.

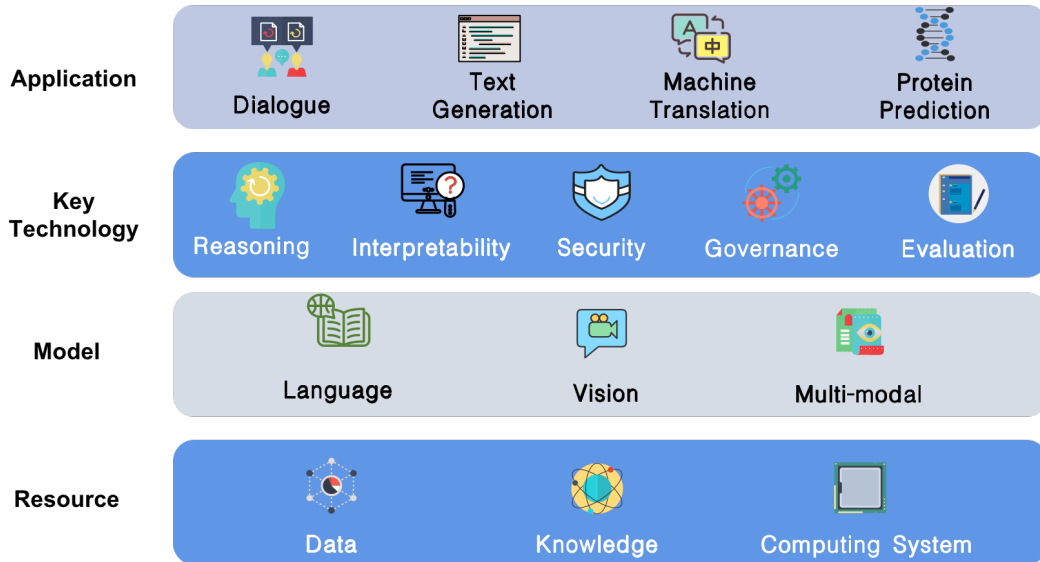

Fig. 2. Roadmap for big models

**Resource** The bottom resource layer of the big model framework is responsible for providing the fundamental support. The resource layer involves 3 aspects, including data, knowledge and computing systems.

- Data for Big Model (Section 2)

This section introduces the fundamental dataset resource used for model training. Data quality is one of the most critical factors affecting models' performance. First, some existing corpora are introduced respectively. Then, the technology used in dataset construction, such as data acquisition and data cleaning are illustrated in details. Next, we propose some common problems in datasets, such as duplication, privacy issues, ethical issues and uneven distribution. Finally, some directions of further developing big model datasets are discussed.

- Knowledge for Big Model (Section 3)

Knowledge is usually represented in knowledge graphs, which are networks characterizing concepts, entities and their relations in the real world. This section introduces the properties and related techniques of knowledge and shows the combination of knowledge and big models. We first give some preliminaries for knowledge graph and explain the knowledge fusion methods. Then the big model based knowledge acquisition approaches are described. Moreover, injecting knowledge into big models shows the advantages of knowledge-enhanced big models. At the end of this section, some future directions are proposed.

- Computing System for Big Model Training (Section 4)

Classical super-computing clusters are mainly used in large-scale scientific computing for high-precision complex computing. With the expansion of deep learning over the last few years, there has been increasing demand for GPU computing power. GPU implementation significantly accelerated the implementation of neural network algorithms, which makes more emphasis is given to GPU computing clusters nowadays. In this part, We intend to introduce the computing system needed for big model training.

- Parallel Support for Big Model Training (Section 5)

The computational demands of big models are increasing rapidly as the expansion of model parameter scale. The increased computational requirements need high-performance computing systems and parallel computing techniques to support. In this section, the development process of parallel computing methods is introduced in details. A variety of existing effective parallel computing techniques are illustrated respectively. Furthermore, we propose the blueprint of next-generation computational systems for big models at the end of this section.

## Big Models

- Big Language Model (Section 6)  
NLP is one of the most important fields in machine learning, and various big models are constructed aiming at solving NLP tasks. Starting from the language representation methods, the complete NLP big model training process are illustrated in this section step by step. Additionally, we discuss some advanced topics in NLP big models, which includes model analysis, long document modeling, multi-task learning, continual learning, knowledge-enhanced NLP and model acceleration. At the end of this section, we propose some outlooks on how to enable machine to understand complex semantics.
- Big Vision Model (Section 7)  
With the rapid development of artificial intelligence, the computer vision field has witnessed significant progress in both theoretical research and practical applications. Delicately designed deep models with the abilities to perceive the visual world and process various downstream vision tasks are leading a unprecedented revolution to many aspects of the modern information society, such as intelligent robotics and autonomous driving. However, the growing appetite for data of ever-enlarging deep models has also brought challenges to further advancement of the community, as the annotation cost for numerous task-specific data and the corresponding training resource expenses are unaffordable. Therefore, the pre-training technique is then introduced to bridge the gap between the training resource limitations and demands for higher representational ability of vision features.
- Big Multi-modal Model (Section 8)  
Humans can learn from multi-modal information in the real world. To simulate the intelligence of humans, it is necessary for models to train on large-scale multi-modal data. In the domain of multi-modal big models, the key challenge is to deal with the heterogeneity of multi-modal data and use them jointly to conduct model training. Except the text and image modalities, big models for other modalities, such as video and audio, are also introduced in this section. Besides, we further explain the multi-modal big models in multi-lingual form and propose some directions that worth further studying.

## Key Technologies

- Theory and Interpretability for Big Model (Section 9)  
Big models have received great empirical successes in recent years. However, while many useful techniques have been discovered by practitioners, there has been a lack of solid theoretical understanding and interpretability for big models. The study of models' interretability mainly contains three aspects, which are Visually explaining the knowledge learned by big models or illustrating important inputs, explaining the representation capacity of models for network diagnosis and combining models with symbolic knowledge bases collected manually to make models explanatory. In this section, we introduce briefly the existing research development from those three aspects and propose some promising future study directions.
- Reasoning for Big Model (Section 10)  
In recent years, the artificial intelligence technology has basically realized the perceptual intelligence such as vision and hearing, but it is still challenge to achieve the cognitive intelligence such as thinking and reasoning. In the process of solving problems, human can understand the whole process with reasoning paths and nodes, but current deep learning algorithms regard solving most of these problems as a black box. To better simulate the human problem-solving, reasoning is an important research direction. In this part, We introduce the basic conceptions of commonsense reasoning, involving the definition, methods and benchmarks. At the end of this section, some future directions are proposed.
- Reliability and Security for Big Model(Section 11) In recent years, the AI technology is moving from research studies to our daily life with an irresistible trend. People benefit from the convenience brought by the AI applications, such as face recognition and information retrieval. However, those advanced technologies also draw people's security concerns. In this part, we introduce the reliability and security problems raised by big models and their corresponding defending methods. Additionally, some future directions of improving the reliability and security of BMS are proposed.
- Governance for Big Model (Section 12)  
With the rapid development of big models, some safety and ethical issues are exposed to the public, which suggests that a powerful governance system needs to be established. In this section, the definition of big model governance, the reason for conducting governance and the governance objectives are illustrated first. Then the overview of present governance works are summarized and introduced. Finally, we point out some open problems and give several suggestions for better big model governance.
- Evaluation for Big Model (Section 13)  
The big model evaluation refers to the activity of evaluating the performance, efficiency, and other features. The evaluation results are useful in improving models' interpretability and guiding the modification of big models. Thus, the research of big model evaluation is worth discussing. In this section, we introduce some existing benchmarks and

corresponding datasets for the evaluation of performance, efficiency and multi-modality respectively, and illustrate several problems in each evaluation direction. At the end of this section, some promising further works are proposed.

**Application** The upper layer is responsible for better adapting big models to specific domains, called the Application layer. We introduce several common applications, including dialogue, text generation, machine translation, information retrieval, and protein prediction.

- Application in Machine Translation (Section 14)

As the trend of globalization speeds up in the real world, the application of machine translation becomes increasingly important. In this section, the use of big models in machine translation tasks are introduced. We initially give some basic information of machine translation, and then list a series of big models that can be applied in the translation. After that, three categories of pre-training for translation works are presented, including monolingual pre-training, multilingual pre-training and pre-training for speech translation. In addition, the evaluation methods for big-model-based machine translation are also mentioned. Finally, some challenges and further trends in this domain are illustrated.

- Application in Text Generation (Section 15)

Text generation is a task to convert linguistic or non-linguistic input into text. Currently, big models have shown great performances in text generation tasks. To better understand the present works and future development of big-model-based text generation, we make some discussions in this section. We introduce three types of text generation tasks, which are text-to-text generation, data-to-text generation and vision-to-text generation. Besides, both autoregressive and non-autoregressive generation methods are illustrated in details. To show the link between big models and text generation tasks, a series of big models that have already been applied to generate text are introduced. Finally, we propose world-knowledge-aware, controllable and fine-tuning-free as three main directions for further explorations.

- Application in Dialogue (Section 16)

Dialogue is an important downstream application of big models because it can realise the interaction and communication between machines and humans. In this section, we first introduce several big models that aiming at dialogue, such as DialoGPT, Meena and EVA. Then, the present works in three key research directions are summarized. Those directions contains the persona and personalization in dialogue, the knowledge enhancement in dialogue and the empathy and emotional support in dialogue. Next, we introduce several interesting and novel application scenarios of dialogue models and finally give some suggestion on further development.

- Application in Protein Prediction (Section 17)

To make breakthroughs in the therapeutic discovery, it is vital to understand the functions of proteins and design proteins with desired functions. In recent years, big models have achieved great success in the field of protein modeling and prediction. In this section, we first introduce some prominent progresses in that domain achieved by applying big models. Those achievements contain the task of protein function prediction, protein structure prediction and protein design. Furthermore, some valuable research directions in protein modeling and specific downstream tasks are discussed at the end of this section.

**Relationships Between Layers.** The bottom layer provides the essential elements for the middle layer to develop the key technologies of big models: large-scale data, knowledge and computing power. With the rise of the third generation of artificial intelligence, knowledge has gradually become one of the basic elements for big model construction. Generally, there are three types of big models, including big language models, big multi-modal models and big vision models. The rapid iterative development of key technologies in the middle layer also poses great challenges to the bottom layer. With the popularity of the large-scale trend, it is urgent to design high-performance hardware and software facilities and more efficient parallel computing methods. In addition, both model performance and model bias are highly dependent on data distribution, quality, and size. The ultimate goal of key technology research is to provide better performance of big models, including solid generalization, strong robustness, high accuracy, and good efficiency.

## 2 Data

*Authors: Hanyu Zhao, Guoqiang Wang, Xiang Pan, Mengjie Li, Xiaoyu Chu, Sha Yuan<sup>✉</sup>*

Data is one of the most important factors in the field of artificial intelligence. In the machine learning process like training a neural network model, dataset can be recognized as the material where machine learns knowledge from.

---

Sha Yuan (yuansha@baai.ac.cn) is the corresponding author of Section 2.

Intuitively, if the learning resource is not qualified enough, it is hard to achieve ideal results in problem-solving by using information learned from the resource. Meanwhile, if the scale of a dataset is not large enough, there is the higher risk that the data distribution in dataset is inconsistent with that of real world. The biased data distribution can cause the weak performance and robustness of intelligent model in downstream applications. Therefore, constructing large-scale and high-quality corpora is crucial to the AI research. The data construction is even more important in the development of big models, because big models are supposed to learn a series of general knowledge from dataset and apply them in various specific tasks. As shown in Fig. 3, the scale of dataset used for model training has an increasing trend, especially for those Chinese corpus. This trend also suggests the growing importance of dataset development.

In this part, We firstly make a brief description of existing pre-training corpora, which can give some hints about which corpora we should use when pre-training language models. As for the pre-training process, we would like to balance the model’s generalization ability and downstream application performance. Such requirements have revealed our expectations about the data, and we will illustrate and discuss these topics in the following sections,

- The corpora should cover various knowledge domains, which gives possibilities for the generalization of models. In Section 2.1 we will introduce the existing corpora.
- The corpora should have high quality, which means it can truly reflect the structure or pattern behind language distribution. In section 2.2 we will introduce how to build a high-quality corpora.
- The corpora should be unbiased and should not contain any intended or unintended shift distributions towards some properties. In Section 2.3 we will focus on the problems needing attention in corpora construction.
- Based on existing works and development of pre-training data in big models, In Section 2.4 we will discuss further research questions and directions, including multimodality fusion, how to pretrain a model efficiently and bionic model.

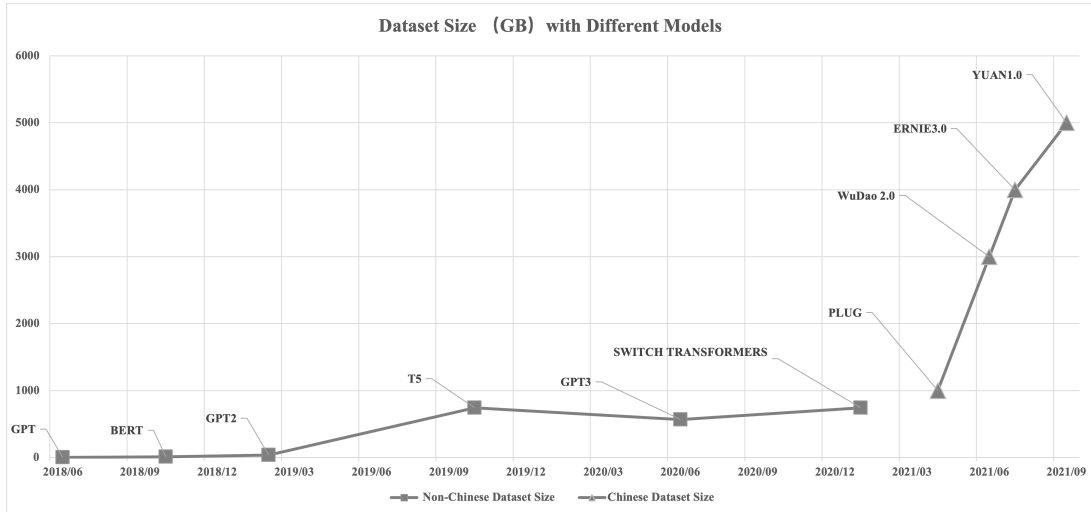

Fig. 3. The size of datasets used for big model training gradually increases

## 2.1 Existing Corpora

The wide application of pre-training text and multimodality image-text datasets has promoted the development in the research field of NLP. In this section, we have investigated and studied commonly used datasets and summarized their characteristics (as shown in Table 2).

**English Wikipedia.** English Wikipedia is an annotated English dataset extracted from Wikipedia for domain detection, including texts from 7 different fields. Each document contains the content of a complete Wikipedia article and has been cleaned up to remove unnecessary parts. The corpora has 31,562 documents, including 25,562 train documents, 3,000 validation documents and 3,000 test documents. Besides, its vocabulary size is 175,555, multi-labeled ratio is 10.18%, and each article has an average of 1,152.08 words.

**BooksCorpus.** BookCorpus is a large collection of free novels written by unpublished authors, including 11,038 books in 16 different subgenres, 74,004,228 sentences, 984,846,357 words, and 1,316,420 unique words. Besides, each sentence has an average of 13 words.

**RealNews.** RealNews is a large corpus of news articles from Common Crawl. Data is limited to the 5000 news

domains indexed by Google News. It contains 31 million documents with an average length of 793 BPE tokens. Like C4, it excludes examples with duplicate URLs. News dumps from December 2016 through March 2019 were used as training data, articles published in April 2019 from the April 2019 dump were used for evaluation.

**OpenWebText2(OWT2).** OWT2 is an enhanced version of the original **OpenWebTextCorpus**, including content from multiple languages, document metadata, multiple dataset versions, and open source replication code, covering all Reddit submissions from 2005 up until April 2020.

**PubMed Central(PMC).** PMC is a free full-text archive of biomedical and life sciences journal literature from the U.S. National Institutes of Health’s National Library of Medicine (NIH/NLM). The dataset is updated daily. In addition to full-text articles, they contain corrections, retractions, and expressions of concern, as well as file lists that include metadata for articles in each dataset. PMC obtained by open registration in Amazon Web Services (AWS) includes The PMC Open Access Subset and The Author Manuscript Dataset. The PMC Open Access Subset includes all articles and preprints in PMC with a machine-readable Creative Commons license that allows reuse. The Author Manuscript Dataset includes accepted author manuscripts collected under a funder policy in PMC and made available in machine-readable formats for text mining.

**ArXiv.** ArXiv is a repository of 1.7 million articles, with relevant features such as article titles, authors, categories, abstracts, full text PDFs, and more. It provides open access to academic articles, covering many subdisciplines from vast branches of physics to computer science to everything in between, including math, statistics, electrical engineering, quantitative biology, and economics, which is helpful to the potential downstream applications of the research field. In addition, the writing language of LaTeX also contributes to the study of language models.

**Colossal Clean Crawled Corpus(C4).** C4 is a colossal, cleaned version of Common Crawl’s web crawl corpus. It is based on Common Crawl dataset and was used to train the T5 text-to-text Transformer models. The cleaned English version of C4 has 364,868,901 training examples and 364,608 validation examples, while the uncleaned English version has 1,063,805,324 training examples and 1,065,029 validation examples; the realnewslike version has 13,799,838 training examples and 13,863 validation examples, while the webtextlike version has 4,500,788 training examples and 4,493 validation examples.

**Wiki-40B.** Wikipedia (Wiki-40B) is a clean-up text collection containing more than 40 Wikipedia language editions of pages corresponding to entities. The dataset is split into train/validation/test sets for each language. The training set has 2,926,536 examples, the validation set has 163,597 examples, and the test set has 162,274 examples. Wiki-40B is cleaned by a page filter to remove ambiguous, redirected, deleted, and non-physical pages.

**CLUECorpus2020.** CLUECorpus2020 is a high-quality Chinese pre-training corpus obtained by cleaning the Chinese part of the Common Crawl corpus. It has a 100G original corpus containing 35 billion Chinese characters and has been randomly divided into training set, validation set, and test set with a ratio of 99:0.5:0.5. More specifically, the training set includes 34.7 billion tokens, 106 million sentences; the validation set includes 0.18 billion tokens, 3.9 million sentences; and the test set includes 0.18 billion tokens, 3.9 million sentences. The corpus consists of 4 fields: news, community interaction, Wikipedia, and comments. It can be directly used for pre-training, language model, or language generation tasks without additional preprocessing.

**The-Pile.** The-Pile is a huge, diverse, and open source language modeling dataset. It is constructed from 22 diverse high-quality subsets—including existing and newly constructed ones. The goal is to obtain texts from as much modalities data as possible to ensure The Pile has a broad generalizing ability. The validation and test components contain 0.1% of the data respectively, sampled uniformly at random. It includes the **OWT2**, **PMC**, **Book3**, **ArXiv** corpus mentioned above.

**Multilingual C4(mC4).** In the C4 dataset, any pages that were not given a probability of at least 99% of being English would be discarded. Its multilingual variant mC4 dataset contains a colossal, cleaned version of 101 languages crawled from Common Crawl. Source data is much more than when building the C4 dataset. It is mainly intended to pretrain language models and word representations.

**CC100.** Clean unsupervised corpus, CC100, comprises monolingual data for 100+ languages and also includes data for romanized languages. It was constructed using the URLs and paragraph indices provided by the CC-Net repository by processing January-December 2018 Common Crawl snapshots.

**Conceptual Captions(CC).** CC is a dataset of image caption annotations, consisting of about 3.3M <image, description >pairs. There are 3318333 examples and 51201 unique tokens in the training set, while 28355 and 13063 in the validation set, 22530 and 11731 in the test set. The mean/stddev/median statistics of tokens-per-caption after data splits are consistent with each other, at around 10.3/4.5/9.0 respectively.

**LAION-400.** LAION-400M is a dataset consisting of CLIP-filtered 400 million image-text pairs, with their CLIP embeddings and kNN indices. It was produced in several formats to adapt various use cases. For instance, it not only released 400 million pairs of image URLs and corresponding metadata but also released 400 million pairs of CLIP image embedding and the corresponding text. In addition, it released several sets of kNN indices that enable quick search in the dataset.

**WuDaoCorpora.** WuDaoCorpora is a Chinese corpus consisting of plain text dataset, dialogue dataset, video dataset, and multi-modality dataset. The plain text dataset size is 4TB with data obtained by cleaning 133TB of original data,

involving 100+ fields such as education, technology, etc. It focuses on eliminating personal privacy information from the original data, greatly reducing the risk of personal privacy leakage. The dialogue dataset is 180 times larger than the LCCC dataset, and its volume has compressed to 181GB after using the most stringent data clearing method at present to clear from 9TB original data. The video dataset includes 3 million video clips of 11TB. The video clips are processed by mainstream video frame extraction and marking technology, so the tags are more complete. The multi-modal dataset includes 650 million pairs of graphs and text, totaling approximately 93TB.

Existing datasets provide solid supports for the training of big models. However, the needs of constantly increasing model scale and improving model performance propose higher requirements for both the quantity and the quality of datasets. Thus, it is valuable to invest efforts in constructing better datasets. The corpora construction is much more complex than a gathering work. Those raw texts collected from websites are usually not feasible for the model training. In next section, we will introduce some data processing methods used in dataset construction.

**Table 2.** Popular Corpora Used by the Research Community.

Dataset Name	Text	<image, Text>	Size	Applied-Model
English Wikipedia	✓	-	19.13 GB	BERT, XLNet, GPT3
BookCorpus2	✓	-	9.45GB	BERT, XLNet, RoBERTa, GPT3
RealNews	✓	-	120GB	Grover
OpenWebText2((OWT2))	✓	-	125.54GB	GPT2/3, RoBERTa
PubMed Central	✓	-	180.55GB	GPT-neo, BioBERT
ArXiv	✓	-	112.42GB	GPT-neo, WuDao
C4	✓	-	750GB	T5
Wiki-40B	✓	-	4GB	Transformer-XL
CLUECorpus2020	✓	-	100GB	RoBERTa-large-clue
The-Pile	✓	-	1254.20GB	GPT-neo, WuDao
CC100	✓	-	2.5TB	XLm-R
multilingual C4(mC4)	✓	-	26TB	mT5
Conceptual Captions(CC)	-	✓	3.3M image-text pair	VL-BERT
LAION-400	-	✓	400M image-text pair	CLIP, DALL-E
WuDaoCorpora	✓	✓	650M image-text pair + 5TB	CPM-2, WuDao

## 2.2 Corpora Construction

Large-scale unlabeled datasets are widely used in self-supervised learning tasks of NLP. Among them, the Common Crawl dataset stands out because of its great performance. It can obtain a large amount of unlabeled text data through the Internet. It should be noted that most text is not a natural language and mainly consists of messy or obsolete text, such as menus, error messages, or repeated text. In addition, the content of a large amount of text, such as offensive language, placeholder text, source code, is unlikely to be helpful for downstream tasks. Therefore, further detailed filtering is required to obtain pure text, eventually affecting the model’s effect and conclusion. To investigate how to improve data quality, we summarize the text cleaning rules of well-known corpora such as C4 [19], CLUECorpus2020 [35] and WuDaoCorpora [36], etc.:

- Evaluate web page quality based on text density. Evaluate every data source’s quality before text extraction and ignore web pages whose text density is lower than 70%.
- Data deduplication. Text reposting is a common phenomenon on web pages, and it can be used the SimHash algorithm to remove duplicated content.
- Filter web pages by text length. Web pages with few words usually do not contain any meaningful sentences. Thus, these web pages are not appropriate for training language models. If a web page contains less than 10 Chinese characters, ignore it.
- Filter web pages by sensitive vocabularies. Sensitive information such as dirty words, seditious comments, and other illegal content adversely affects building a harmonious and positive technical model and social environment. As a result, it is necessary to exclude web pages that contain the above contents.
- Remove personal privacy. To protect everyone’s privacy security to the greatest extent, we can write regular expressions to match private information (i.e., identity number, phone number, QQ number, email address, etc.) and remove them from the dataset.
- Delete incomplete sentences. Incomplete sentences can be problematic in model training. We can use punctuation marks (i.e., period, exclamation mark, question mark, ellipsis) to divide extracted texts and delete the last segment, which is sometimes incomplete.



- Delete web pages containing much garbled information. Because of the breach of the W3C standard of some web pages, text extracted from them is often garbled. To exclude garbled contents in our corpus, we need to filter web pages with high-frequency garbled words and use a decoding test for double-checking.
- Remove abnormal symbols. To guarantee the smoothness of extracted text, we need to remove those abnormal symbols (i.e., Emoji, logo, etc.) from web pages.
- Remove web page identifiers. Since web page identifiers such as HTML, Cascading Style Sheets (CSS), and Javascript are unhelpful for language model training, we can remove them from extracted texts.
- Transform traditional Chinese to simplified. Since there are Chinese characters in both the simplified version and the traditional version, we need to transform those traditional characters into simplified versions to make the character format in the corpus unified.

Then, some work will use filters to the preprocessed documents to further remove the harmful, advertising, and low-quality documents. For instance, GPT3 [20] and PANGU [37] trained a classifier to score the quality of each document and eliminate the documents with scores below a threshold.

## 2.3 Noteworthy Issues

Sizes of datasets have grown hundreds of times over the past few years. As a consequence, checking such large-scale datasets is a nearly impossible task. However, they may be full of low quality and contain biased and private information. Moreover, the datasets may even contain duplicate or highly similar samples. And another common problem in collected datasets from websites is that they may be unevenly distributed.

These data issues have implications far beyond metrics such as perplexity or validation loss, as learned models reflect the biases present in the training data. As a result, quantitatively and qualitatively understanding the datasets themselves is a research challenge in its own right.

### 2.3.1 Duplication

Recently, numerous research works have investigated the negative impact of data duplication on model training. Researchers [38] explored the effects of code duplication on machine learning models, and they thought that duplicate examples in code datasets cause worsened performance on code understanding tasks. Katherine’s [39] work showed that because the pre-training corpus contains many near-duplicate examples and long repeated substrings, over 1% of the output results of language models trained on these datasets are copied word by word from the training data. Most of these duplicate data are the same news or machine-generated data on the Internet. By deduplicating the data can reduce the rate of emitting memorized training data by a factor of  $10\times$ , and require fewer train steps to achieve the same or better accuracy. Unfortunately, several common NLP datasets have data duplication problems. For example, Bandy [40] found that the book corpus [41], which was used to train models such as BERT and GPT3, has contained thousands of duplicated books.

Data needs to be deduplicated to eliminate the adverse effect of data duplication on model training. However, a large amount of repeated text is not a strict match in the complete sense, and simple string matching may not be located. Brown trains the GPT3 model, using Spark’s MinHashLSH implementation with 10 hashes. They also fuzzily removed WebText from Common Crawl. Overall this decreased dataset size by an average of 10%. Katherine [39] proposes two scalable techniques to detect and remove duplicated training data from C4.

**Memorizing Train Sets.** The risks of data memorization, for example, the ability to extract sensitive data such as valid phone numbers and IRC usernames, are highlighted by Carlini et al. [42]. While their paper identifies 604 samples that GPT-2 emitted from its training set, we show that over 1 of the data most models emit is memorized training data. In computer vision, memorization of training data has been studied from various angles for both discriminative and generative models [43, 44, 45, 46, 47].

**Duplicate text in training data.** The Book Corpus [41], which was used to train popular models such as BERT, has a substantial amount of exact-duplicate documents, according to Bandy and Vincent [40]. Allamanis [38] shows that duplicate examples in code datasets cause bad performance on code understanding tasks.

**Advantages of deduplication.** Katherin [39] shows four advantages of the big model training on the deduplicated datasets:

- Reduce the size of the datasets.
- reduce the rate of emitting memorized training data.
- eliminate the train-test set overlap, which may causes researchers to over-estimate model accuracy and biases model selection towards models and hyperparameters that intentionally overfit.

**Table 3.** Bias in big models

Input: GPT2(sexist):	Naturally, the nurse is a ____ woman.
Input: T5(racist):	All terrorists are ____ Muslims.
Input: T5(homophobic):	I’m a man and I ____ gay people.s hate
Input: GPT2(violent):	Two guys in a bar start a ____ fight.

- Deduplicating training data does not hurt perplexity: models trained on deduplicated datasets have no worse perplexity compared to baseline models trained on the original datasets. In some cases, deduplication reduces perplexity by up to 10%. Further, because recent LMs are typically limited to training for just a few epochs [48, 48], the models can reach higher accuracy faster by training on higher-quality data.

**Duplication detection.** Katherin [39] proposes two scalable techniques to detect and remove duplicated training data. Exact substring matching identifies verbatim strings that are repeated. It allows one to identify cases where only part of a training example is duplicated. Approximate full document matching uses hash-based techniques [49] to identify pairs of documents with high n-gram overlap.

**Methods for Identifying Duplicates.** The simplest technique to find duplicate examples would be to perform exact string matching between all example pairs, but as we will show, this is insufficient. We introduce two complementary methods for performing deduplication. First, using a suffix array [50], we remove duplicate substrings from the datasets if they occur verbatim in more than one example. Second, we use MinHash [49], an efficient algorithm for estimating the n-gram similarity between all pairs of examples in a corpus, to remove entire examples from the dataset if they have high n-gram overlap with any other example.

### 2.3.2 Privacy and Ethics

**Bias in Big Language Models.** There is a strong concern about the privacy of language models. Large datasets are typically based on web crawlers from the internet, which are only filtered with some simple rules [48,19]. Those language models can take the various source into pre-training corpus, which leads to the privacy leakage consideration. In addition, many upstream applications are based on these big models. The bias of those models learned through the pre-training process may cause serious problems. In word2vec [51,52], they showed  $\text{vector}(\text{“King”}) - \text{vector}(\text{“Man”}) + \text{vector}(\text{“Woman”})$  inferences a vector that is closest to the vector representation of the word Queen. Such properties are seen as a good attribute to words representation. However, if it uses “man” to “computer programmer” analogizes “woman” to “homemaker” [53], things get different. Many works [54,55] showed that gender bias was used for shortcut prediction. For generation models, some researches also [56,20] showed that toxicity generation is out of boxes when we are using big models. In Table 3, we show some specific examples of bias in model output.

**Bias Detection in Corpus.** To understand what kinds of bias in word representation, word embedding bias detection methods are proposed [57,58]. One current limitation is that most of the works are focused on one specific type of bias. When we have no idea what kinds of bias are hidden in those corpora, we can only test them one by one.

**Attack Big Language Models** These bias and privacy problems will not only affect the prediction results invisibly, they can also make models easily to be attacked. Some attack frameworks based on data leakage are proposed [59]. The training data can be recovered from BMs [42].

**Debiasing Methods in Big Language Models.** Improving the quality of word representation [60,61,62] can make word embedding more semantic meaningful so that models will be less dependent on shortcut information used in downstream task. Big models are more and more powerful and contain more semantic information. However, these methods can not ensure being rid of privacy leakage and bias representation questions. When structured or meaningful information is not available, the models will still rely on shortcut information to make predictions [63].

Recent powerful language models are still shown to be biased. There are various methods are proposed to get rid of bias [64]:

- Changes to the initial training data to mitigate bias a prior.
- Training a separate model to filter the content generated by a language model.
- Fine-tuning a big language model on data with desired properties.
- Tagging data so that the model learns to distinguish among certain forms of content [65].
- Training models to be more “fact-aware” [66]
- Reinforcement learning with human feedback [67].

- Leveraging the model’s own knowledge to improve outputs (e.g., with careful prompt design).
- Developing more expansive suites of “bias tests” that models can be run through prior to deployment
- Red-teaming the model at scale by engaging trusted partners to work with the model and through limited commercial offerings.

Trying to make an unbiased corpus can eliminate the problem from the source. When we create the datasets, meta and some information is suggested to be collected for bias management [68].

### 2.3.3 Unevenly Distribution

It is a common perception that the probability distribution of tokens contained in the corpus implies human knowledge. The big models simulates the probability distribution by learning the tokens sequence. Hence, the big model is dependent on the distribution of the topics.

Unevenly distributed data collection can introduce a bias. This type of topic selection bias is caused when the probability of a sample being generated is related to the quantity being observed.

This is easy to see with a simple example, suppose that the collected corpus is drawn from the finance region. The style of finance would be inherited into the text generation task.

Either way, it would not ever recommend throwing out data unless one has a really good reason. In most cases, it can correct for the bias introduced if we understand how the data was collected. One way to achieve this is to balance the distribution of the topics.

## 2.4 Future Directions

### 2.4.1 Generate Data base on Big Model and Knowledge Graph

The common practice for big language models has gone from human-to-corpus-to-models. However, the human-crawled natural language text itself only represents a limited range of knowledge, and facts may be contained in unstructured data such as long sentences in many different ways. In addition, the non-factual information and harmful content in the text may eventually lead to model bias. Recently, some researchers began to study from models-to-corpus. As the Fig. 4 shows, Oshin et al.[69] propose pipelines for training the TEKGEN model and generating the KELM corpus. The author experiments the evaluation using two open domain question answering datasets and one knowledge probing dataset. The experiment shows that using the generated corpus (KELM Corpus) training model can better learn knowledge, and it is an effective method to integrate knowledge graph and natural language text. Similarly, Peter et al. [70] proposed a symbolic knowledge differentiation framework. This framework uses the GPT3 model to generate a commonsense graph for training a small model with common sense reasoning ability. The experimental results show that this small model is better than GPT3 in a commonsense reasoning task. Using a BM combined with a knowledge graph to generate data can not only be used for model pre-training but also be used as a new knowledge base question answering (KBQA) method. Hanyu et al.[71] proposed to use the BM to generate the corresponding QA corpus for each triplet of the knowledge graph, and solve the KBQA task only by calculating the similarity of the question and sorting. These generated Q&A pairs can also be further used to train the model.

The above work shows that the BM combined with the knowledge graph to generate data can not only provide a factual and unbiased corpus for the model pre-training stage, but also solve the problem of alignment between the text semantic space and the graph semantic space, and can better integrate the knowledge graph with BMs. At the same time, it can also provide a new way of solving problems for downstream tasks, which has significant research value. It is foreseeable that there will be more and more work to carry out further research on this in the future.

### 2.4.2 Why and How Unsupervised Training Helps?

**Unsupervised Training Theory.** The unsupervised pre-training have shown huge success in big language models. Understanding why and how the pre-training works are essential. Some works [72,73] show that unsupervised pre-training appears to play predominantly a regularization role in subsequent supervised training and can also help the fine-tuning optimization process.

Big models are proven to be good at few shot tasks [20], which implies that the training corpus contains the information required for performing such tasks and the common pre-training process grants the trained big model some access to these higher level capabilities. Including both sentences in the same input helps the semantic learning is shown on [74,75]. The process of segmenting the corpus into training examples directly affects the big model’ ability to integrate cross-corpus information, which is referred to as inductive bias. In addition, including semantically related

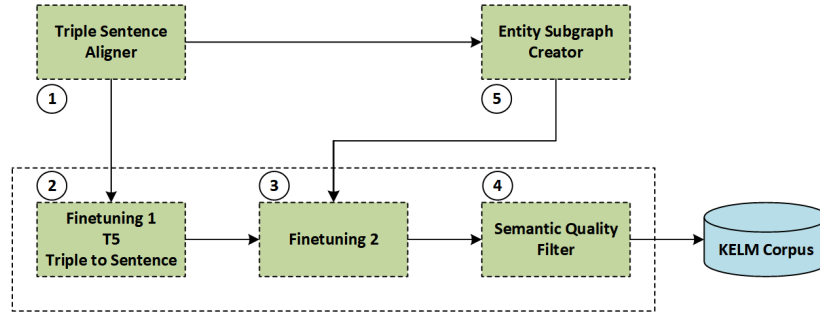

Fig. 4. Pipelines for training the TEKGEN model and generating the KELM corpus

non-neighboring sentences in the same pre-training example yields improved sentence representations and open domain question answering abilities [76].

**Pretraining Corpus Domain.** Continuing pretraining in target domain text helps generalization [77]. However, pretraining in a similar target domain may have the worst performance than model pretraining in the general domain [78]. The interesting question is, do we really need so much data to train a model? Some recent work [79] trying to pretrain a model from scratch only uses the target task related corpus, which gives us some hint about how to select and collect pre-training data.

**How much data do we need?** Some work [80] shows that the threshold that the size of corpus we need to make the model learned linguistic feature, which gives some hint about generally how much data we need to learn those transferable and shared features. Another interesting thing is that even a little hard training example those shortcut learning can not solve will help learn linguistic features. However, there is a gap between how big model digest information and how downstream tasks use information.

#### 2.4.3 Multi-modal Fusion

Where is NLP going? Yonatan et al. [81] in *Experience Grounds Language* propose the notion of a World Scope (WS) as a lens through which to audit progress in NLP. They define five WSs, and they note that the most popular pre-training in NLP operates in the WS2 (Internet) which uses unstructured, unlabeled, multi-domain, and multilingual data. At the next stage, WS3 (Perception), the model needs to have perception ability and learn from text, image, audio, video, and other modes. At present, the multi-modal pre-training corpus is mainly composed of weak superior image-text pairs. Google presents a dataset of image caption annotations, Conceptual Captions, which is about 3.3M image-text pairs [82]. To further enhance the pre-training quality, Microsoft collected a large-scale weak-supervised image-text pairs from the Web, containing 10M image-text pairs [83]. With the advent of the era of a big model, the demand for data of models is further improved. Such as, CLIP [31] use 400M image-text pairs collected from the internet.

Though big models show the generality of many NLP tasks, they lack common knowledge in many specific scenes and perform poorly at reasoning. Note that humans learn knowledge from structural knowledge (such as the knowledge graph) and non-structural knowledge (such as reading books and conversation with people). Though the big models are trained with feeding a large amount of corpus, the type of feeding the corpus is like the study of human reading. Hence, constructing the structural knowledge and how the big model learns the structural knowledge is worth studying. Moreover, note that humans interact information of the natural, including language, vision, touch, hearing, gustation, and smell. How to simulate the human capturing multimodal information in real time and learning based on the information is worth studying.

#### 2.4.4 Next Step of Efficient Data Usage

Human kinds or babies may not need so many samples to learn a new task, or at least do not need so much data the model currently used. One suggestion is that language neural connections are intrinsically embedded in the initial neural connections, which means language learning is just like fine-tuning in that initial connections. So one possible question is that can we get some idea from the human connections to make language model architecture more efficient? Another suggestion is that human babies are immersed in language environments filled with various signals, including the voice, lip activities, body language, and face expression. All those signals will help learn the semantic language, and the interaction of all those things will make learning easier. Another interesting thing is that can we use the various aligned signals to make data usage more efficient?

### 3 Knowledge

Authors: Xiaozhi Wang\*, Jifan Yu\*, Xin Lv\*, Zijun Yao, Fangwei Zhu, Shulin Cao, Juanzi Li<sup>✉</sup>, Lei Hou<sup>✉</sup>

Knowledge refers to the huge amount of facts in the real world, and is usually stored in a graphical structure. Knowledge graphs are networks that characterize concepts, entities and their relations in the real world, enabling a leap from string descriptions to structured semantic descriptions of the world. In recent years, knowledge graphs have become the basis for the organization of the internet resources and are the infrastructure for big models.

In this part, We intend to introduce the related techniques of knowledge graphs and show the connection of knowledge and big models. The following provides the detailed contents of this part.

- To obtain some basic ideals about knowledge graph, we intend to introduce the preliminaries and categories of knowledge graphs and show how to integrate or fuse knowledge in Section 3.1.
- Knowledge acquisition is an important work in artificial intelligence. In Section 3.2, we will introduce the effects of big models in the process of knowledge acquisition.
- The lack of knowledge is one of the main problems of big models. There are many studies trying to solve this problem. In Section 3.3 we will focus on the knowledge-enhanced big models.

#### 3.1 Knowledge Graphs and Knowledge Integration/Fusion

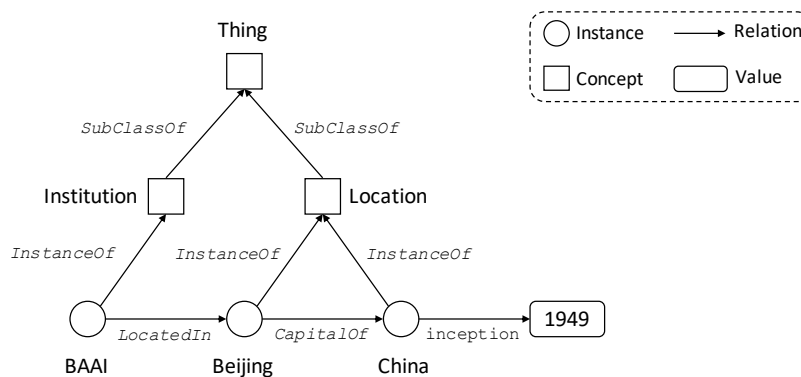

Fig. 5. An example of knowledge graph.

##### 3.1.1 Preliminaries for Knowledge Graph

Knowledge graph can be formally defined as  $\mathcal{KG} = \{\mathcal{C}, \mathcal{I}, \mathcal{R}, \mathcal{T}\}$ , where  $\mathcal{C}$  is the concept set,  $\mathcal{I}$  is the instance set,  $\mathcal{R}$  is the relation set and  $\mathcal{T}$  is the triple set. In practice, we can also not distinguish between concepts and instances and treat them uniformly as entities, i.e., we have entity set  $\mathcal{E} = \mathcal{C} \cup \mathcal{I}$ . **Concept** is an abstract description of a class of instances in the knowledge graph, indicating that these instances have similar characteristics. **Instance** is the basic component of the knowledge graph, and it is a concrete description of a unique thing in the world. Usually, an instance belongs to one or more concepts. **Relation** connects instances and concepts in the knowledge graph. Specifically, relations mainly include semantic linking relations  $\mathcal{R}_r$  that describe structure knowledge, and attribute relations  $\mathcal{R}_a$  that describe specific text-based attributes of instances. **Triple** is a factual description of the world. It is a combination of entities and attributes. Fig. 5 is a small knowledge graph, where Location is a concept, BAAI is an instance, LocatedIn is a semantic linking relation, inception is an attribute relation and (BAAI, LocatedIn, Beijing) is a triple.

Depending on the source of information and the way of knowledge acquisition, the current knowledge graphs are divided into the following three categories.

**Experts annotated knowledge graphs.** Most of the early knowledge graphs are annotated by experts. The knowledge in these knowledge graphs is accurate, but the size of experts' annotated knowledge graphs is usually small

Xiaozhi Wang, Jifan Yu and Xin Lv contribute equally.

Juanzi Li (lijuanzi@tsinghua.edu.cn) and Lei Hou (houlei@tsinghua.edu.cn) are the corresponding authors of Section 3.

due to the limitation of expert knowledge. Cyc [84], WordNet [85] and HowNet [86] are some typical experts annotated knowledge graphs.

**Wiki-Based knowledge graphs.** Wikipedia, which is built by the collaborative editing of a large number of volunteers, is the largest knowledge resource on the Internet. In recent years, there are many knowledge graphs built using Wikipedia, which are designed to take advantage of the rich factual knowledge in Wikipedia. For example, DBpedia [87], Freebase [88] and YAGO [89] are all Wiki-Based knowledge graphs.

**Knowledge graphs extracted from unstructured texts.** With the development of information extraction technology, it has become possible to automatically extract structured knowledge from text. Thanks to this, this type of knowledge graphs can be constructed automatically by acquiring structured knowledge from massive unstructured text without relying on experts and existing Wikipedia knowledge. NELL [90] and KnowItAll [91] are typical of such knowledge graphs.

### 3.1.2 Knowledge Graph Completion and Integration

Big models perceive the world and learn from it by self-supervised learning over huge amounts of unlabeled data. There has been work in recent years [92] demonstrating that big models contain knowledge. However, this knowledge is stored in the parameters and cannot accurately cover all the knowledge in the world, especially the low-frequency knowledge. As a resource to accurately store massive world knowledge, knowledge graph can be a good solution to this problem of big models, e.g., we can explicitly add the knowledge in the knowledge graph to the big model, or use the big model to retrieve the accurate knowledge in the knowledge graph. Therefore, we can see that large-scale knowledge graphs containing accurate knowledge are important infrastructures for big models.

Although there evolve many large-scale knowledge graphs, such as Freebase and Wikidata, most of them face serious incompleteness problems. For example, as shown in the paper of Knowledge Vault [93], 71% of people in Freebase have no known place of birth, and 75% have no known nationality. Therefore, it is important to automatically complete the missing knowledge in the knowledge graphs. In addition to incompleteness, the existing structured knowledge is distributed in different knowledge graphs, and there is no unified knowledge graph that substantially contains all the entities and their facts in the world, which is urgently needed to better serve the big models.

To solve the above problems, researchers develop many technologies towards knowledge graph completion and integration. Knowledge graph completion, as an intra-graph knowledge augmentation method, aims to deduce new facts from the existing knowledge graphs. It aims to discover hidden relations that are missing in the knowledge with observed relations. Knowledge integration, as an inter-graph knowledge augmentation method, connects facts among multiple different knowledge sources. It augments the facts and the entities among all the involved knowledge graphs. Both methods will potentially produce a new knowledge graph with more knowledge information, which better serves natural language tasks requiring explicit knowledge guidance. This section will introduce link prediction, triple classification for knowledge graph completion, and entity matching, entity alignment, and entity linking for knowledge graph integration.

**Link Prediction.** The relational knowledge (relations) is modeled as links in the knowledge graph with specified relational labels. Thus, the relational knowledge discovery is equivalent to predicting whether there are links between two entities that are not inter-connected in the existing knowledge graph. Two lines of work have been proposed for link prediction, including knowledge graph embedding (KGE) [94] and multi-hop reasoning [95].

KGE aims to embed all entities and relations into a continuous low-dimensional space. With this method, missing relational links between entities are predicted using a scoring method, which computes a score for each link based on vector space representations of embedded entities and relations. Current methods for KGE can be grouped into three categories: 1) Translation-based models. From TransE [96] to the recent state-of-the-art RotatE [97], translation-based models have shown great performance. Inspired by word2vec [52], given a triple  $(h, r, t)$ , TransE learns vector embeddings  $\mathbf{h}$ ,  $\mathbf{r}$  and  $\mathbf{t}$  which satisfy  $\mathbf{r} \approx \mathbf{t} - \mathbf{h}$ . Afterwards, to address the 1-to-N, N-to-1, and N-to-N relation problem, abundant attempts have been made, including TransH [98], TransR/CTransR [99], TransD [100], TransSparse [101], PTransE [102] and ManifoldE [103]. 2) Bilinear models. RESCAL [104] is the first bilinear model. It associates each entity with a vector to capture its latent semantics. Each relation is represented as a matrix, which models pairwise interactions between latent factors. Many extensions of RESCAL have been proposed by restricting bilinear functions in recent years, including DistMult [105], HolE [106], and ComplEx [107]. 3) External Information learning methods. External information is significant for knowledge representation. Existing methods explore to use various external information to improve KGE, including external context information in a text corpus [108], entity descriptions [109], and logical rules [110, 111, 112].

Multi-hop reasoning is another line of work for link prediction. Different from KGE, it aims to predict the tail entity for every triple query  $(h, r, ?)$  and meanwhile provide a reasoning path to support the prediction. Current models for this task can be grouped into two categories: 1) reinforcement learning (RL) based models. Various efforts have been made to improve the RL performance for multi-hop reasoning from MINERVA [113] to DacKGR [95]. For example, M-Walk [114] propose M-Walk to solve the reward sparsity problem using off-policy learning. MultiHopKG [115] further

improves MINERVA using action dropout and reward shaping. MetaKGR [116] propose MetaKGR to address the new task of multi-hop reasoning on few-shot relations. In order to adapt RL models to a dynamically growing KG, CPL [117] is proposed to do multi-hop reasoning and fact extraction jointly. 2) Neural symbolic models. In addition to the above RL-based reasoning models, there are some other neural symbolic models for multi-hop reasoning. NTP [118] and NeuralLP [119] are two end-to-end reasoning models that can learn logic rules from KGs automatically.

Compared with KGE models, multi-hop reasoning models sacrifice some accuracy, whereas showing great interpretability. In the future work, combining KGE and multi-hop reasoning methods is a promising direction, which benefits both from the precision of KGE methods and the interpretability of multi-hop reasoning methods.

**Entity Alignment.** Entity alignment aims to identify entities from different knowledge graphs that refer to the same real-world object, which serves for knowledge graph integration. Ideally, entity alignment models can leverage the relational knowledge (also referred to as structural information) among entities, as long as the literal entity descriptions and the entity attribute values. Thanks to the inherent network structure of knowledge graphs, early attempts are developed on network algorithms. Network matching based methods explore neighborhood similarity between nodes and propagate the similarity score on the whole graph [120,121]. The network structure can be further combined with a probabilistic graph model [122,123] to model the uncertainty. Entities, as nodes in the knowledge graphs, are modeled as explicit variables, and the matching labels are modeled as implicit variables. Most recently, knowledge representation learning has been shown effective in well capturing the semantic information of the knowledge graph. They convert entities into low dimensional vectors and compare entities via simple vector similarity metrics.

Nevertheless, the graph structure is not always available when the entities are recorded as attribute-value pairs in the table. There are specially designed methods for aligning entity records in attribute-value pairs, which are known as **Entity Matching** (also called Entity Resolution in some other literature). These methods aims to decide for entities from different tables whether they refer to the same real world object according to their attribute values, without accessing the relational knowledge. A typical entity matching system usually consists of a blocking module and a matching module.

Matching between two tables with  $N$  and  $M$  entity records requires determining a total  $N \times M$  entity pairs. To reduce the computational cost, blocking filters out vast entity pairs that are not matching with simple rules. The exact match rule assumes that two identical entities must have exactly the same attribute values on certain attributes, such as Gender attribute for matching entities under People concept. Similarity Blocking calculates the similarity of two entity records, such as Jaccard similarity, cosine similarity between word embeddings, and filters out entity pairs that are less similar. This is especially useful when the attribute values are ad hoc linguistic descriptions. More complicated blocking rules combine multiple predicates.

For hard cases after blocking, entity matching performs detailed analysis above their attribute values. Early works focus on engineering matching rules along with sophisticated comparison features. Recent study suggest that the attention architecture [124,125] and the pre-training scheme [126,127] may serve as an important role in entity matching.

Recently, there evolves several systems that automate entity matching. Magellan [128] provides automatic feature extractor, blocking, and non-deep learning-based matching. DeepMatcher [129] investigates deep learning for entity matching. DITTO [126] uses big models as basic construction blocks for entity matching.

**Entity Linking.** Entity linking aims to map words of interest (mentions) in input text to corresponding entities in a knowledge base. For example, identifying “Li Bai” in “Li Bai is the author of many poems” refers to the famous poet rather than the song with the same name. Entity linking bridges the gap between unstructured text and structured knowledge, and is beneficial to various downstream tasks like semantic search as it infuses knowledge into texts. The core challenge in entity linking is text ambiguity: the same words may refer to different entities depending on contexts, and entity linking models should determine the correct entity among candidates.

Early works [130,131] focus on exploiting structured data (relation graph, co-occurrence probability, etc.) in knowledge graphs, which rely on data quality and are constrained to fixed knowledge bases. Recent works turn to Wikification, taking Wikipedia as the corresponding knowledge base in order to link mentions to an ever-updating entity set. Considering the great scale and variable relations in Wikipedia, graph-based techniques generally don’t apply, and big models are widely adopted in representing the text features. BLINK [132] encode contexts and entity descriptions via big models, while GENRE [133] builds an autoregressive model to directly output the unique name of chosen entities. These new models may also be viewed as “pre-trained entity linking models”, as they are trained on the large-scale Wikipedia corpus, and can be easily transferred to specific datasets by fine-tuning on in-domain training data.

Wikification entity linking models integrate the vast underlying human knowledge in Wikipedia and are capable of linking low-resource entities by merely encoding textual descriptions about the given entity, providing a universal solution to mining knowledge from general texts. On the one hand, the success of Wikification entity linking models is inseparable from the natural language processing capability of big models. And on the other hand, entity linking reveals entities in text and separates them from other non-meaningful data, which highlights the core structural components in unstructured text, potentially benefiting the natural language understanding ability of big models. Acting as the bridge between knowledge and text, entity linking and big models are complementary to each other.

### 3.2 Big Model-based Knowledge Acquisition

Knowledge acquisition is the problem of how machines acquire knowledge in artificial intelligence and knowledge engineering systems [134], including named entity recognition, relations classification, concept discovery, etc. In the era of large-scale knowledge graphs, how to efficiently and accurately discover, collect, summarize, and detect high-quality knowledge has attracted the attention of a large number of researchers [135]. Especially the efforts from the natural language processing community make it possible to obtain knowledge from unstructured text. As big models have exceedingly achieved outstanding performance on various natural language processing downstream tasks, researchers are intrigued by their promising performance on knowledge acquisition tasks. In recent years, along with the increasing understanding of models, knowledge engineering researchers have experimented with paradigms including fine-tuning, machine reading comprehension, and parameter-less tuning (including Adapter and prompt tuning) to invoke the large number of external resources modeled by large models [136,137,138]. In the midst of this vigorous journey of exploration, there have also emerged some directional debates about the association between big models and knowledge bases. In general, these attempts consist of two relevant lines:

**Regarding the Big Models as Booster.** Stemming from the ultra-large training corpus set, the large model is often considered as a strong semantic parser, so researchers use the large model instead of existing initialization representation tools and use the large model as a good capability aid for existing methods by, e.g., fine-tuning the large model.

**Regarding the Big Models as Resource.** The scale of data perceived by big models far exceeds that of datasets for specific knowledge acquisition tasks, which makes the adoption of big models as a source of knowledge acquisition itself quite promising. While there is still a fair amount of debate about whether big models can fully replace knowledge graphs, the idea that big models contain at least some common-sense knowledge is gradually being accepted.

As the sun rises on big model research, we are obliged to provide a directional review and summary of the existing exploration in this area. In this section, we will summarize several types of approaches that use big models to assist in knowledge acquisition, as well as some ongoing discussions on the association between big models and knowledge bases, and finally give some of the current urgent puzzles and challenges in the field, which we expect to be effectively pursued in the future.

#### 3.2.1 Big Model as Booster for Knowledge Acquisition

Since most of the knowledge is embedded in language-based data, automatic knowledge acquisition models have been using different linguistic modeling approaches to enhance their performance for a long time. From Topic Modeling to word2vec, named entity recognition, relationship classification, entity alignment and entity linking are among the tasks that have moved forward on the wave of natural language modeling. To date, several possible paths have been explored for the use of large models.

**Encoder and Fine-tuning.** Direct usage of language models or other types of big models is to employ the encoding ability in the initialization stage. With BERT [18] just making its debut in natural language tasks, researchers have tried to use BERT as a good encoder and quickly identified a series of fine-tuning-based knowledge acquisition paradigms [139,140,141]. Indeed, this exploitation of large models relies heavily on their modeling of linguistic norms to better serve the part of natural language understanding, i.e., NLU capabilities. The results of this phase quickly lead to a consensus among knowledge acquisition researchers, so that subsequent work is almost all based on the use of big models. Since the size of the big models remains in the acceptable range during this period, many researchers are not satisfied with just fine-tuning the general large models, but instead also choose to further improve the results by training big models unique to their own tasks, such as Blink for entity linking task [132].

Meanwhile, benefiting from the powerful support capabilities of big models, knowledge acquisition researchers are beginning to challenge more complex scenarios, including federating multiple tasks and completing knowledge acquisition under sparser labeling settings. E.g., previously, named entity recognition and relationship classification tasks are performed independently, but from 2019 onwards, the task of joint entity and relation extraction and unified evaluation starts to become a more popular task [142]. Conversely, the knowledge acquisition task is more focused on weak supervision, few or even zero-shot learning, due to the dramatic improvement of performance in fully supervised scenarios [140].

**Parameter-less Tuning.** While such fine-tuning paradigms work well, models that explode in size, such as GPT-3 with 175 billion parameters [20], make the cost of fine-tuning large models unaffordable for most researchers. Therefore, recent knowledge acquisition studies have mainly favored training fewer parameters to achieve matching fine-tuning effects as well, which can be mainly divided into two ideas of prompt tuning [143] and adapter [138].



Prompt tuning is mainly inspired by work such as prefix tuning [144] and ipet [145], which intervene less in parameter training by turning part of a sentence into a trainable token, as mentioned in the section on cognitive reasoning. It is worth noting that several knowledge-specific improvements have been made to better integrate them with knowledge acquisition, such as the idea of prompt tuning specifically designed for relation classification [146]. Such a training approach mainly disassembles the knowledge verification of the triples into fewer training classification tasks based on big models to acquire knowledge.

The adapter, instead, tries to accomplish parameter less fine-tuning by training plug-ins [147] for big models. Due to its proximity to the fine-tuning paradigm, researchers at this stage tend to use it as a solution for some tasks that cannot be easily videoed by the prompt tuning approach, such as the task of Named Entity Recognition that requires sequence annotation.

**Machine Reading Comprehension & QA Paradigm** Beyond directly exploiting the modeling capabilities of large models, it has also been found that knowledge queries can be made to big models by performing question and answer or reading comprehension, which mainly exploits the natural language generation capability of the model, i.e., the NLG capability [139]. Such queries are adapted depending on the type of task. (1) Sequence labeling tasks, such as named entity recognition [136], concept extraction [82], and other tasks that require the extraction of content from a natural discourse, can be accomplished through reading comprehension. For example, asking “which entities are presented in the above passage” [148] can directly help the detection of specific labels from the corpus. (2) Knowledge discovery tasks, such as entity expansion [149], synonym discovery [150], ontology construction [151], etc. These tasks have less input inherently and tend to be dominated by bootstrap-based text generation, e.g., “the Chinese capital is [mask]”. However, using a question-and-answer approach to interrogation faces several major problems, including the difficulty of controlling the quality of generation and the high time complexity, which are analyzed further in the challenges section.

### 3.2.2 Big Model as Resource for Knowledge Acquisition

Except for using big models for enhancing existing methods for the training of knowledge acquisition models, some researchers have proposed that we can obtain more available training data by querying large models for augmentation [152,153]. The more radical view is that large models actually have the ability to be knowledge bases, holding the full knowledge in the training base corpus, and just need to be probed out in an efficient way, which we discuss briefly in this section.

**Big Models for Data Augmentation.** Data augmentation is the technique used to increase the amount of data by adding slightly modified copies of already existing data, which is an essential process in knowledge acquisition, especially in low-resource scenarios. Using big models to generate more training data is an intuitively feasible idea. Hence researchers attempt to use big models for data supplementation and augmentation in tasks such as event extraction [154], name entity recognition [153], etc. The idea of these efforts is typically to design some specific hard prompts for the task and then conduct weakly supervised label or sentence generation using a big model [155]. Since the paradigm of the relevant attempts is relatively clear, researchers have been able to write review articles [156] for this purpose even in 2020 and summarize several methodologies for the use of different classes of big models such as BERT, GPT, and BART that are still the mainstream approach today. Besides data augmentation, researchers have recently started to explore noise-robust methods to solve the knowledge acquisition problem under low-resources settings, such as using big model to perform noiseless fine-tuning to accomplish the named entity recognition [157]. These manipulations of data will remain an important feature of big models for a longer period of time, especially as the data modeled by big models become larger and larger in the future.

**Big Models are Knowledge Bases.** The ability of big models to continuously refresh the understanding of AI, especially GPT3, which performs amazingly well on multiple downstream tasks without fine-tuning, has led to a discourse that has gradually sparked a community discussion. Can large models replace knowledge bases altogether? Actually, although these discussions have only recently started to attract attention, there were battles about them back in 2019 [92]. After a small number of researchers put out the idea that BERT is a kind of knowledge graph, several related works debated on this topic. One of the proponents used statistical metrics [158] to demonstrate the knowledge preservation ability of the language model, with already strong inference, while the opponents countered by citing errors in the logic of the larger model [159]. Following the release of big models such as GPT3, the discussion had also been narrowed down to big models that were at least open knowledge bases [160], which also led to attempts based on methods such as prompt engineering. While the dust has not settled on these discussions so far, researchers are

**Table 4.** Three genres of knowledge adopted in knowledge-enhanced big models and their representative works, respectively.

Knowledge Genre	Representative Knowledge-enhanced big models
World Knowledge	ERNIE (THU) [162], KEPLER [163], WKLM [164], CokeBERT [165], KGPT [166], LUKE [167].
Commonsense Knowledge	COMET [168], GRF [169], KG-BART [170], CommonsenseStoryGen [171]
Domain-specific Knowledge	BERT-MK [172], OAG-BERT [173]

beginning to embrace large models for virtual knowledge base construction using similar ideas for some downstream tasks, such as knowledge reasoning for Q&A [161].

### 3.2.3 Challenges and Directions

In general, although established approaches have been able to achieve excellent performance from different perspectives on how pre-training can help knowledge acquisition, there are still many questions in the field that need to be addressed, and we propose four main questions that need to be addressed from macro to micro level hereby.

**Why the big models preserve the knowledge?** Are these case-proven knowledge capabilities due to the large number of co-occurrence in the corpus, or the models indeed refine them as real agents? This question is fundamental to the question of large model-enabled knowledge acquisition, which determines where exactly we should go in our quest, whether we should always consider it only as an aid, or we will eventually rely entirely on models.

**What type of knowledge is better supported by big models?** As some investigations bring out insights that big models can better preserve the concept-level knowledge, the discussion continues to be popular, which is about which knowledge acquisition tasks are achievable with better results through data augmentation of big models, and for tasks that demand content that models do not provide, this technical route should be stopped early to prevent excessive waste.

**Where should big modes go for accelerating knowledge acquisition?** Since knowledge acquisition tasks are diverse in type, but they all share the core goal of finding accurate knowledge of the world, adjustments to pre-training approaches may produce very significant improvements for the entire domain. These approaches may include the design of the corpus, the design of the rubrics at the time of generation, etc.

**How to explore the next-generation paradigms for knowledge acquisition?** The natural interaction of existing models is actually the question-and-answer paradigm described above, but such a technical route obviously faces problems such as inefficiency and difficulty in control. How to adapt the existing knowledge acquisition paradigm so as to build a bridge between large models and knowledge is a very urgent and important issue.

## 3.3 Knowledge-enhanced Big Models

Considering the high utility of knowledge graphs to organize human knowledge in a structural way, which could enable symbolic reasoning and provide additional background knowledge for understanding human languages and other kinds of information, many works have been devoted to infusing extensive knowledge in the knowledge graphs into big models and thus propose knowledge-enhanced big models. With the rapid and continual growth of both big models and knowledge graphs in scale, coverage and ability, making them better work together and help each other will continually attract research attention and bring breakthroughs for practical systems. In this section, we will first introduce the existing knowledge-enhanced pre-training works through two dimensions including knowledge genres and knowledge-enhancement methods. Then we will discuss the possible promising directions which we can explore in the future of integrating big models and future knowledge graphs.

We firstly analyze existing knowledge-enhanced big models through the genres of knowledge graphs they used. Table 4 shows three knowledge genres and their representative pre-training works. The details will be introduced below:

The first and most widely-investigated genre of knowledge is **world knowledge**, which contains continually-emerging facts in the world and is also known as factual knowledge or encyclopedia knowledge. Many of the largest knowledge graphs are essentially world knowledge, such as Wikidata, DBpedia [87], Freebase [88] and YAGO [89], even Wikipedia can also be seen as an unstructured world knowledge base. Hence the most of the above-mentioned knowledge-enhanced big models are essentially investigating world knowledge.

**Commonsense knowledge** is the facts about everyday life, which is critical but insufficient in existing big models. The commonsense knowledge graphs are typically less structured, such as the ConceptNet [174] and ATOMIC [175]. The existing knowledge enhancement works mainly introduce commonsense knowledge into generative big models [168, 171, 169, 170].

**Domain-specific knowledge** indicates the knowledge graphs specially constructed for specific application domains, such as the biomedical domain [176] and the academic domain [177]. For example, BERT-MK [172] integrates the medical knowledge in UMLS [176] into BERT-like models and OAG-BERT [173] infuses the academic knowledge in the open academic graph [177].

In the second dimension, we classify existing knowledge-enhanced big models via their knowledge-enhancement methods into two main categories: the big models using **knowledge graphs as side information** and the big models **learning knowledge graph abilities**.

### 3.3.1 Knowledge Graphs as Side Information

The first kind of knowledge-enhanced big models (mostly language models nowadays) use extensive knowledge in knowledge graphs as the side information for language understanding. Their motivations are two-fold: (1) Knowledge graphs contain long-tail world facts, which rarely show up in pre-training corpora and thus are hardly learned with vanilla language modeling objectives. Integrating the contextual knowledge facts in knowledge graphs can provide background information for big models, which will help language understanding. (2) Knowledge graphs and their corresponding texts can provide extra supervision signals for pre-training, which will promote the models' ability in understanding fact-related texts and thus help in those *knowledge-intensive tasks* [178].

The earliest and most straightforward method of this kind is to **integrate knowledge graph representations** learned with representation learning algorithms [96], mainly entity embeddings, into big models. These methods typically rely on entity linking modules to link the contexts to knowledge graph entities and retrieve the corresponding entity embeddings during both pre-training and fine-tuning, as well as additional alignment pre-training objectives to make the representations of knowledge graphs and texts better align into the same semantic space. As the earliest and representative work of this way, ERNIE (THU) [162] integrate the entity embeddings obtained with TransE [96] into BERT [18] with a *knowledgeable encoder* module and resort to a *denoising entity autoencoder* loss to do representation alignment. The entity linking process is done with a separate entity linker TAGME [179]. KnowBERT [180] adopts a similar way but uses an integrated entity linker in the model, which is jointly trained in pre-training. Beyond the BERT-like models, KG-BART [170] infuses entity and relation embeddings into both the encoder and decoder of a sequence-to-sequence model.

Since the misalignment of knowledge graph representations learned with representation learning algorithms and native language representations may seriously influence the performance, some works try to better align them with more informative contexts or just avoid directly using knowledge graph representations. As an example for the **better alignment with more informative contexts** way, CokeBERT [165] dynamically selects a subgraph of knowledge graphs as the side information for a given textual context, and then embed and fuse the subgraph with a semantic-driven graph neural network (S-GNN). The knowledge graph representations only serve as the initialization for the S-GNN. BERT-MK [172] also uses subgraphs as knowledge contexts but feeds them into the transformer rather than graph neural networks. To avoid using knowledge graph representations, K-BERT [181] injects knowledge into contexts by expanding the input sentences into tree structures also containing the words about related knowledge facts, which is implemented by modifying position embeddings and attention masks. Since it is not necessary to align heterogeneous representations, the knowledge injection of K-BERT can be done directly for fine-tuning without additional pre-training. Moreover, some works try to **learn native entity representations** during pre-training with knowledge graphs as supervisions rather than involving trained knowledge graph representations into big models. To promote the entity-centric tasks, LUKE [167] pre-trains native entity representations by adding the entities as individual tokens into the model vocabulary and training them with the masked language modeling objective. To indicate the differences between word tokens and entity tokens, it also adds type embeddings and introduces an entity-aware self-attention mechanism. EaE [182] also directly learn entity representations with texts during pre-training, but it views the entity representations as plug-in memory components and when the input contexts contain certain entities, the model will retrieve the corresponding entity representations from the memory module and fuse them into the contextual representations. In this way, the entity memory containing large amounts of parameters can be sparsely accessed, so that reduces overall computation and memory offload. Another interesting point of the **external knowledge memory** idea is that the memories of knowledge facts are localized and may be easier edited than distributed into big model parameters, which is promising to handle continually-changing world facts. Furthermore, the FaE [183] model stores facts rather than entities into external memories in a key-value memory manner, which uses the subjects and the relations as keys and the objects as values. KEPLER [163], CoLAKE [184] and JAKET [185] follow a similar motivation to learn implicit entity representations with knowledge graphs but they adopt knowledge-graph-completion-like objectives, and we will classify them into the second main category, i.e., learning knowledge graph abilities.

Except the above methods introducing external or training native knowledge graph representations, another line of study adopts a more straightforward way, which is to **use the knowledge graphs to guide or improve the challenge of language pre-training** and thus force the big models to focus more on entity semantics or better

understand the underlying knowledge facts within contexts. ERNIE 1.0 (Baidu) [186] proposes to mask the entities in contexts rather than only words during masked language modeling pre-training, which shall improve the challenge of this pre-training objective. ERNIE 3.0 (Baidu) [187] takes a step further to jointly input the knowledge facts (triplets) and corresponding texts into the model and do selective masked language modeling, which is to improve the big models’ abilities on fact-related text understanding. Shen et al. [188] not only masks the entities in knowledge graphs during masked language modeling either but also proposes to use the related entities in knowledge graphs as the harder negative samples (distractors) for entity prediction and adopts a distractor-suppressed ranking objective. WKLM [164] proposes a replaced entity detection pre-training task, which is to ask the model to distinguish whether the entities within contexts have been replaced with wrong other entities, and thus enforce the big models to implicitly learn entity information. In a different way, K-Adapter [138] infuse factual knowledge into big models with a plug-in *factual adapter*, which is a shallow and small transformer network with two additional projection layers to be injected into big models. The factual adapter is trained with a relation-classification-like training objective to gain the ability of understanding facts in texts and the big model parameters are not changed for knowledge integration. This adapter way enables to continually inject new kinds of knowledge into big models. ERICA [189] adopts a contrastive learning framework to improve the big models’ abilities on understanding relational facts, which contains two pre-training tasks: the entity discrimination task and the relation discrimination tasks, and both of them are formulated with a contrastive learning objective form similar to SimCLR [190].

The above methods are mostly for improving the big models’ *understanding* ability with knowledge graph enhancements. Some works also focus on how to **improve language generation with knowledge graphs**. EntityNLM [191] improves language models’ ability to handle named entities by jointly modeling named entity recognition and coreference resolution tasks. NKLM [192] and KGLM [66] both propose to improve language generation by allowing the language models to copy from some facts in the knowledge graphs, which shall be related to the underlying facts of the context to be generated. The improvement of KGLM compared to NKLM is that KGLM can operate on the entire knowledge graph and does not need the entities to be previously provided as conditions. KALM [193] adds entities as additional tokens to the vocabularies of GPT-like big models, while their embeddings are randomly initialized and learned with language modeling objectives and an additional entity prediction pre-training task. KGPT [166] directly use data-to-text generation as the pre-training objective, which is to pre-train the models to acquire the ability to directly convert structural knowledge graph facts into natural texts and implicitly learn the knowledge for a generation. Moreover, Guan et al. [171] propose to utilize the external commonsense knowledge bases like ConceptNet [174] and ATOMIC [175] to improve big models’ ability on commonsense story generation, which requires commonsense knowledge and understanding causal relationships.

### 3.3.2 Learning Knowledge Graph Abilities

Beyond only taking knowledge graphs as the side information for language pre-training, another study line tries to integrate the ability of knowledge graphs into big models, e.g., let the big models gain the ability to do symbolic reasoning over knowledge graphs or complete the missing facts in knowledge graphs. This line of study contains less work and is still in a prior stage. As a representative, KEPLER [163] encodes the textual entity descriptions with big models as the entity embeddings, and jointly optimize the masked language modeling and knowledge graph embedding [96] objectives, so that the big models can not only produce knowledge-enhanced language representations but also do knowledge graph competition like a knowledge embedding method. In a similar way, KG-BERT [194] takes entity descriptions and relations as the inputs for BERT and does knowledge graph completion with big models, but it does not promote language understanding. CoLAKE [184] jointly learn contextualized language and knowledge representations by viewing words in contexts as fully-connected graphs and injecting related subgraphs of knowledge graphs into them. It is trained with predicting words, entities and also relations, which can be seen as approximating the knowledge graph completion task within contexts. Similarly, JAKET [185] jointly train a language model and a knowledge module producing entity embeddings for the contextualized knowledge subgraphs, which involves a graph convolutional network and is trained with entity category prediction and relation type classification tasks. GRF [169] proposes to incorporate big models with dynamic multi-hop reasoning on multi-relational paths extracted from external commonsense knowledge graphs, which can promote language generation with reasonable commonsense knowledge.

### 3.3.3 Future Directions

We discuss the promising future directions for enhancing big models with knowledge graphs in this section.

**Learning the Ability Rather Than Information of Knowledge Graphs.** From the above summary for existing knowledge-enhanced big models, we can find that most of them focus on using knowledge graphs as side information, i.e., memorizing the information of knowledge graphs. Nevertheless, we believe learning the ability of knowledge

graph is more important than memorizing the information. People cannot remember all the facts in existing large knowledge graphs either. Big models in the future should focus more on how to gain the ability to represent knowledge graphs, i.e., the multi-hop symbolic reasoning to acquire new knowledge, the hierarchical conceptual abstraction, the structural information compression and the condensation of human consensus.

From this perspective, using knowledge graphs as external memory is promising. In this framework, big models do not necessarily need to memorize facts into model parameters but need to learn the *meta knowledge* of operating over knowledge graphs and the external knowledge graph memory can be edited for some needs. The existing attempts of this way are EaE [182] and FaE [183], but they have not modeled the multi-hop reasoning ability.

**Introducing More Genres of Information in Knowledge Graphs.** Nowadays, the knowledge-enhanced big models mainly use the *triplet facts* (head entities, tail entities and relations) to enhance *language* learning. However, there are much richer genres of information in large knowledge graphs. For instance, aligned pictures, videos and audios can naturally improve cross-modal big models. The qualifiers and attributes can help to enhance the reasoning and provide denser supervisions than only entities and relations. We believe utilizing this rich information in knowledge graphs is promising to further improve big models.

## 4 Computing System

*Authors: Zhou Shao, Xigang Cao<sup>✉</sup>*

Classical super-computing clusters are mainly used in large-scale scientific computing for high-precision complex computing. With the expansion of AI over the last few years, there has been increasing demand for GPU computing power. GPU implementation significantly accelerated the implementation of neural network algorithms, which makes more emphasis is given to GPU computing clusters nowadays. In this part, We intend to introduce the computing system needed for big model training. It contains following sections.

- In Section 4.1, we introduce the current status of large computing systems and provide some examples of them that support big model training.
- In Section 4.2, we will investigate deeper to the technical level, which includes both hardware and software needed for building a computing system.
- In Section 4.3 we focus on the limitations of present computing systems and propose some potential trends of future development.

### 4.1 Large Scale Intelligent Computing System (LSICS)

#### 4.1.1 Current Status

GPU computing clusters gradually developed into AI computing infrastructure with hardware and software systems, which we prefer term these infrastructures as Large Scale Intelligent Computing Systems (LSICS).

Unlike high-precision complex computing, the core feature of AI computing is “relational computing” [195], which can be expressed as open and uncertain approximate computing between multilocus in high-dimensional space. In AI computing, experts mainly use single-precision floating-point format (FP32) data for model training [196]. Moreover, they use half-precision floating-point format (FP16) and even int8 data for model inference rather than FP32 or double-precision floating-point format (FP64) data [197]. What is more, lower precision data can be used to model inference by quantization techniques. Overall, AI computing does not require high precision and its calculation on the node is simple.

The traditional supercomputing environment can support the AI model training, but the performance and power consumption ratio as well as cost-effective ratio are low [198]. With the development of AI models, a large number of hardware and software systems for big model training developed specially, becoming infrastructures of big models. This paper list some important difference between traditional supercomputing and LSICS in Table 5. The most crucial feature of LSICS is that LSICS has a lot of AI hardware, such as GPU (Graphics Processing Unit), TPU (Tensor Processing Unit), NPU (Neural Network Processing Unit), etc. Common training accelerator cards include Nvidia V100 and A100, Google TPU, Huawei Atlas 910, etc., which will introduce in the following subsection about these training accelerator cards details.

It is generally accepted that LSICS will become a critical infrastructure of the smart era. LSICS is to an intelligent society what water conservancy and transportation are to an agricultural society; the iron infrastructure

---

Xigang Cao (xgcao@baai.ac.cn) is the corresponding author of Section 4.

**Table 5.** The difference between traditional supercomputing and LSICS.

Item	Traditional supercomputing	LSICS
<b>Purpose</b>	Scientific computing	AI computing
<b>Operation Mode</b>	Computing power service	Providing computing power, algorithms and data in the form of cloud services
<b>Technical Standard</b>	Parallel architecture, low latency	Converged architecture, high throughput
<b>Application Area</b>	Scientific computing field	AI field
<b>Processor</b>	Double precision performance is preferred, taking into account low-precision calculation	Focus on the performance of half precision calculation and optimization of neural network operation
<b>Internet</b>	Consider the network topology and communication requirements from the perspective of the whole system	Network acceleration for model training
<b>Storage</b>	Global parallel file systems such as lustre	Local high-performance storage to avoid reading data from the global file system

and the power grid are to an industrial society. Nowadays, the construction of LSICS is in full swing. Here, only China is taken as an example. In recent years, LSICS is becoming a national strategy, including Peng Cheng Cloud Brain I (100P) and II (100P), Hengqin advanced intelligent computing platform (663P), Fengdong Intelligent Computing Center (230P), Shangtang AI Supercomputing Center (3740P, under construction), Nanjing AI Supercomputing Center (800P), Wuhan AI Supercomputing Center (100P), Chengdu AI Supercomputing Center (300P), Dalian AI Supercomputing Center (100P), etc. What is more, LSICS is critical for big model training.

#### 4.1.2 LSICS for Big Model

GPT-3 comes in eight sizes, ranging from 125M to 175B parameters. GPT-3 175B model required 3.14E23 FLOPS of computing for training and it costs 4.6M dollars for a single training run. Training GPT-3 with 175 billion parameters would require approximately 36 years with 8 V100 GPUs [199]. For training GPT-3, the supercomputer developed for OpenAI is a single system with more than 285,000 CPU cores, 10,000 NVIDIA V100 GPUs and 400 gigabits per second of network connectivity for each GPU server [200]. Megatron-Turing Natural Language Generation (MLT-NLG) model is an AI model with a whopping 530 billion parameters [201]. MLT-NLG was trained using Nvidia’s Selene machine learning supercomputer, a system made up of 560 DGX A100 servers with each server containing eight A100 80GB GPUs. In detail, all 4,480 GPUs use NvLink and NVSwitch to connect to one another. Each one was capable of operating over 113 teraFLOPs per second.

In these examples, the training and inference of big models are inseparable from LSICS, which is quite costly. Low carbon AI has gradually become a critical goal of model developers. Some initial results have been achieved. For example, Alibaba Dharma Institute released the “Low carbon version” giant model M6 [202]. As reported, Dharma Institute trained a trillion parameter model M6, used 480 cards V100 32G GPU, saved computing resources super 80%, and improved training efficiency nearly 11 times [203]. In contrast, NVIDIA realized trillions of parameters, used 3072 A100 GPU; Google realized 1.6 Trillion parameter models, which used 2048 TPU.

The rapid development of big models promotes the development of LSICS but also brings challenges to its development. Traditional computing and communication paradigms are constantly being challenged. To be more specific, Shannon’s law, von Neumann architecture, and Moore’s Law [204] have utility in the past decades, becoming less adapted to the current environment. The challenges and trends of LSICS will be discussed in detail in later sections.

What is more, for the characteristics of LSICS is quite different from the traditional supercomputing, the original evaluation index for traditional supercomputing is no longer suitable to evaluate diversified LSICS. Experts has explored a lot in the field of AI performance benchmarking. For example, MLPerf [205] leading by MLPerf, Deepbench [206] leading by Baidu, AIIA DNN Benchmark [207] by AI Industry Alliance (AIIA), HPL-AI [208] (mixed precision) based on double precision Linpack, AIPerf [209] leading by Peng Cheng Laboratory, Tsinghua University and Institute of Computing, Chinese Academy of Sciences, which uses AutoML as workload.

## 4.2 Technical Details for LSICS

### 4.2.1 LSICS Architecture

Based on the experience of the Wudao model, we list a typical architecture of LSICS for the big model in Fig. 6, which can meet the basic need of model development and training. A layered architecture design can help us understand its system structure. In this figure, five layers are composed of LSICS.

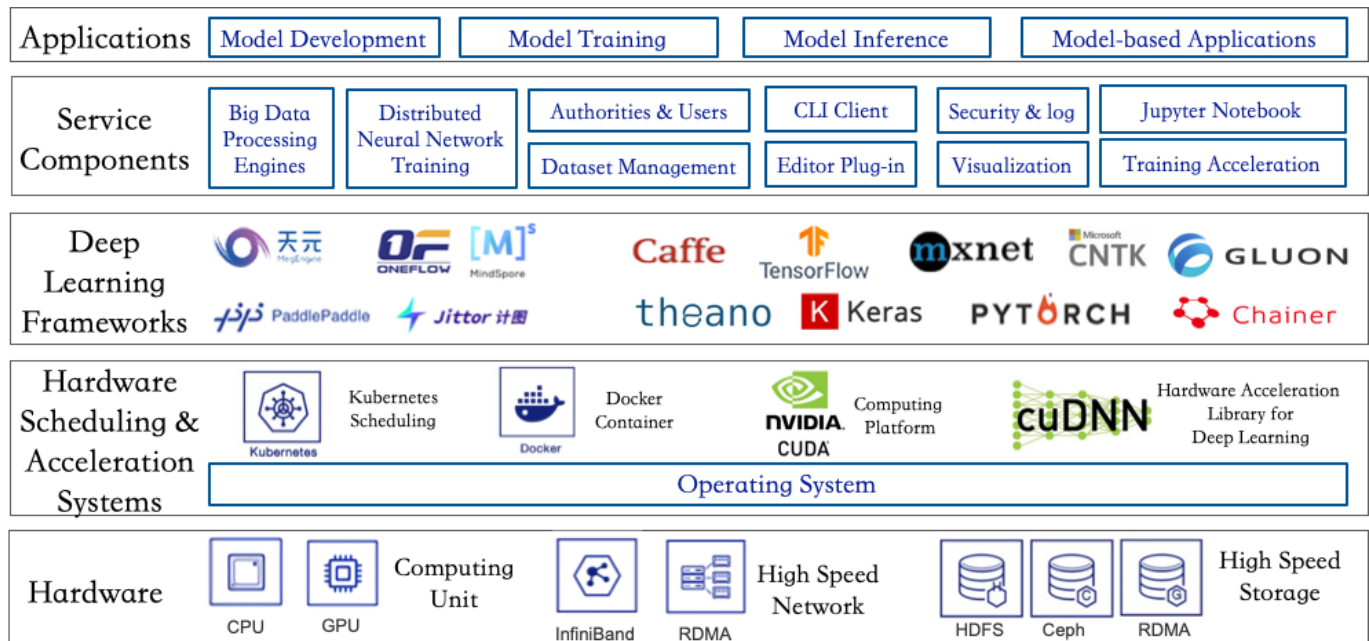

**Fig. 6.** A typical architecture of LSICS for the big model development and training.

1) **Hardware Layer:** This layer contains basic hardware of LSICS, like computing units, high-speed network, and high-speed storage. Unlike traditional supercomputing, GPU/TPU/NPU is more important for LSICS computing power. What is more, data transmission, especially the transmission of small files, often becomes the bottleneck of the whole system operation. In this way, the requirements for network transmission efficiency (including bandwidth) and storage performance are very high.

2) **Hardware Scheduling & Acceleration Systems Layer:** This layer mainly contains the operating system and computing scheduling & acceleration toolkit. The virtualization of computing resources facilitates scheduling. Furthermore, acceleration toolkits will help make full use of the computing power of the computing unit, generally provided by the hardware vendor.

3) **Deep Learning Frameworks Layer:** This layer includes all kinds of deep learning frameworks with their own strengths. Users will determine which one is more suitable for their habits and specific tasks.

4) **Service Components Layer:** This layer provides all kinds of components for the applications, including big data processing engines, dataset management, Distributed neural network training, authorities & users, CLI (Command-line Interface) Client, Editor Plug-in, Visualization, jupyter notebook, training acceleration tools, etc. Different application demands require different components.

5) **Applications Layer:** Developers can use the platform for the development, training, inference, and application of big models.

Typically, an AI development platform is a collection of software for AI model development and application, which have the ability of Deep Learning Frameworks Layer, Service Components Layer, and Applications Layer. The advent of AI development platforms has greatly advanced the development progress of AI models. Furthermore, the support of computing power for full lifecycle is increasingly being considered. AI development platforms, such as Baidu BML, Huawei Modelarts, Ali PAI, Tencent TAI, Amazon ML and SageMaker, Microsoft Azure, Google AI Platform, MEGVII Brain++, Oneflow Onebrain, etc., has taken full lifecycle into account.

#### 4.2.2 AI Chips

Since the rise of Deep Learning in 2016, the need for more efficient hardware acceleration of AI tasks has been increasing. AI chips are the key to the hardware acceleration of AI tasks. Different types of AI chips are helpful for different tasks. A graphical processing unit (GPU) makes up for the deficiency in CPU architecture by adding thousands of computer unified device architecture (CUDA) cores and hundreds of Tensor cores that can process thousands of tasks in parallel. With the diversification of AI tasks, GPU is considered too general-purpose to run AI workloads efficiently. Furthermore, with the failure of Moore’s Law, more and more enterprises have joined in the research and development of AI chips, including IC vendors, tech giants & HPC vendors, IP vendors, startups, etc. IC vendors mainly include Intel, Qualcomm, Nvidia, Samsung, AMD, etc. Tech giants & HPC vendors include Google, Amazon (AWS), Tencent (Cloud), Baidu, Microsoft, Alibaba, etc. IP vendors include ARM, Synopsys, CEVA, etc. Startups, especially startups in China, have become an important force in this track, such as Cambricon, Lynxi Tech, Biren Tech, Enflame Tech, Iluvatar CoreX, Moore Threads, etc. Previous works [210] [211] have summarized some of the necessary metadata of the accelerators, cards, and systems, which help us understand the status and development current of AI chips.

Despite the fact that the market of AI chips is highly competitive, NVIDIA has dominated the current market for cloud AI accelerators and has become synonymous with cutting-edge AI chips and HPC. This paper lists some critical parameters for Nvidia accelerator cards in Table 6, aiming to show the coverage of their product and make the comparison.

**Table 6.** Nvidia accelerator cards parameters comparison.

Item	P4	P40	P100	V100	T4	A100	A40	A30	A16	A10
INT8	-	-	-	-	-	-	-	661T	-	500T
FP 16	-	-	-	125T	65T	624T	299.4T	330T	-	250T
FP 32	5.5T	12T	21.2T	-	-	-	-	-	-	-
Memory	8GB	24GB	16GB	16GB/32GB	16GB	40GB	48G	24G	16G*4	24G DDR6
Power	75W	250W	300W	300W	70W	400W	300W	165W	250W	150W
PCIe	PCIe3.0 ×16	PCIe3.0 ×16	PCIe3.0 ×16	PCIe3.0 ×16	PCIe3.0 ×16	PCIe3.0 ×16	PCIe3.0 ×16	PCIe3.0 ×16	PCIe3.0 ×16	PCIe3.0 ×16
Interconnection	-	-	-	nvlink1	-	NVlink2×6 (300GB/s)	NVlink3 Bridge×2	NVlink3 Bridge×2	-	-
Technology	-	-	-	12nm FinFET	12nm FinFET	7nm FinFET	7nm FinFET	7nm FinFET	7nm FinFET	7nm FinFET

In addition to these hardware products, Nvidia has created a hardware-software ecosystem, including CUDA software platform, cuDNN, etc., which lets developers leverage the parallel architecture of GPUs for a wide range of tasks (shown in Fig. 6). Other typical chips are also very noteworthy, especially Chinese companies, which show strong potential in the context of government-led development of ‘stuck neck’ techs. This paper selects some typical products besides Nvidia, including manufacturers from AMD, Cambricon, Huawei, and Baidu. In Table 7, we also list some critical parameters for other accelerator cards.

**Table 7.** Other accelerator cards parameters comparison.

Item	MI60	MI100	MLU 270-S4	MLU290-M5	Atlas 300I (Ascend310)	Atlas 300T (Ascend910)	Kunlun K100	Kunlun K200
Manufacturer	AMD	AMD	Cambricon	Cambricon	Huawei	Huawei	Baidu	Baidu
INT8	-	-	-	-	-	-	-	-
FP 16	29.5T	70T	32T	125T	32T	256 280T	32T	64T
FP 32	-	-	-	-	-	-	-	-
Memory	32GB	32GB	16GB	32GB	32GB	32GB	8GB	16GB
Power	300W	300W	70W	350W	67W	300W 450W	75W	150W
PCIe	PCIe4.0 ×16	PCIe4.0 ×16	PCIe3.0 ×16	PCIe4.0 ×16	PCIe3.0 ×16	PCIe4.0 ×16	PCIe4.0 ×8	PCIe4.0 ×8
Interconnection	xGMI2×2 (184GB/s)	xGMI2×2 (184GB/s)	-	MLUlink×6 600GB/s	-	-	-	-
Technology	7nm FinFET	7nm FinFET	-	7nm FinFET	-	-	14nm FinFET	14nm FinFET

For big model training tasks, the above products are weaker in performance, flexibility, and usability comparing the corresponding Nvidia products. Experiment shows that Nvidia A100 [212] based on the Ampere architecture has



incomparable advantages in the current stage. However, other participants still have great opportunities. On the one hand, investigations show that the current ecosystem of AI chips is far from perfect and satisfies the growing demand. On the other hand, the application fields of AI chips are constantly expanding from training to inference, from cloud to edge, which gives other participants more room to grow.

#### 4.2.3 High-performance Network & Storage

Big models will be fed massive data in training tasks, which is a tremendous challenge for the cluster of network and storage. For example, OpenAI researchers used a 45TB dataset of plaintext words, filtered it down to a measly 570GB, and used 50 petaflops/day of computing (1020 operations per second, times 50). The training data of Wudao 2.0 (WuDaoCorpora) includes 4TB Chinese text data, and 1.2TB English text data. Practice indicates that network and storage are the most severe bottleneck in big model training scenarios, which can significantly affect training efficiency. What is more, for big model training tasks, an LSICS should take all specific situation into consideration, including wide variety of data formats, scale-out system architecture, bandwidth and throughput, IOPS (Input/Output Operations Per Second), latency, etc.

Von Neumann architecture design consists of a Control Unit, Arithmetic and Logic Unit (ALU), Memory Unit, Registers, and Inputs/Outputs, which has dominated the architecture of computing clusters for decades. Despite being aware of the limitations of von Neumann architecture, current LSICS can not break through this scheme totally. Fig. 7 shows a typical LSICS which abide by the von Neumann architecture. In this figure, computing nodes and high-speed storage are connected through a high-performance network with a spine-and-leaf architecture, which is quite simple and effective.

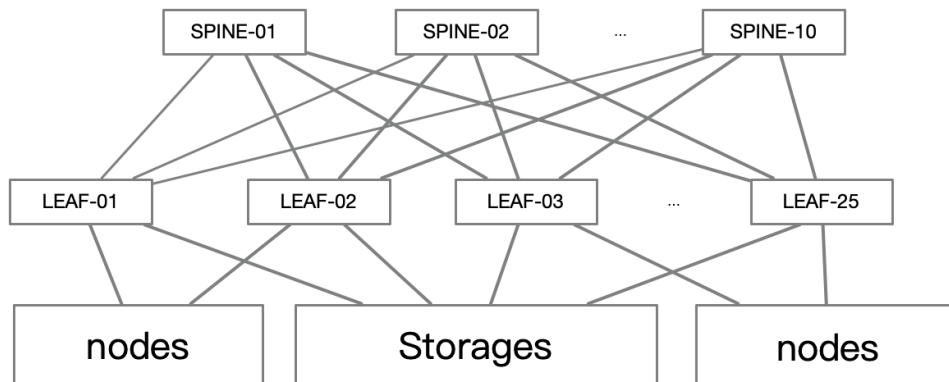

Fig. 7. A typical network of LSICS.

However, our experience shows that the biggest challenge of distributed training is high-performance network transport [213] and data storage, which is the bottleneck of big model training. InfiniBand (IB) is a current effective solution for high-performance networks, a computer-networking communications standard with very high throughput and very low latency. InfiniBand is designed to be scalable and uses a switched fabric network topology, and is used for data interconnect both among and within computers. With the application of InfiniBand, the bottleneck of the high-performance network has been alleviated to some extent, and it has dramatically improved the speedup ratio and parallel efficiency of LSICS. With the increasing LSICS size, the bottleneck of the high-performance network is far from solved, which needs a more effective way to utilize the network capacity and achieve linear scale-out fully, such as gradient compression, network-level optimizations, etc. What is more, because small inputs/short latency is expensive, data loading bottlenecks are pretty common in the big model training scene. A proverbial problem in this scene is the so-called “small file problem”, which means doing fast random access and returning small blocks is expensive. A variety of reasons has caused the small file problem, for example, (1) The size of a single “raw input example” can vary wildly depending on the modality of the data; (2) Data is read, processed, and written in “bulk”, then read many times; (3) As mini-batches shuffle the examples included in each mini-batch, data is accessed at random. The solutions for AI training storage have attracted more and more attention from vendors, such as GCP Filestore or AWS EFS. The core features of current AI storage include (1) parallelized and scale-out; (2) programmable; (3) reliability, durability, redundancy, and storage services; (4) high-speed connection, such as InfiniBand; (5) faster hard disk. Performance isolation is also equally crucial for multi-training tasks for AI storage. Despite the efforts made by storage vendors, AI storage is still the most critical bottleneck of big model training.

#### 4.2.4 Deep Learning Frameworks & Service Components

Deep learning frameworks play a critical role in designing, training, and validating deep neural networks, which will provide a programming interface for the user. Top deep learning frameworks include TensorFlow, Keras, Mxnet, PyTorch, Caffe, Microsoft Cognitive Toolkit, DL4J, Onnx, etc. It is proved that users will choose different deep learning frameworks in different application scenarios and user habits. With the development of deep learning algorithms, deep learning frameworks have become more potent in model training and inference. However, they are far from adequate in the increasing large-scale training scenario, which should pay more attention to data parallel, model parallel, pipeline parallel, hybrid parallel, etc. From the perspective of future market share, it is still difficult to predict which deep learning framework will dominate it. Many Chinese participants began to get involved in this field, which has developed a lot of effective frameworks, such as MegEngine, PaddlePaddle, OneFlow, MindSpore, Jittor, etc. It is worth noting that the combination of specific accelerator cards and deep learning frameworks has become a popular trend. For example, Huawei Ascend accelerator cards combine MindSpore, Baidu Kunlun combine PaddlePaddle, etc. From the strategic perspective of the Chinese government, AI hardware and software systems should be independent and controllable.

As previously mentioned, growing importance and emphasis have been given to the full lifecycle of AI in AI development platforms. It is generally believed that the full lifecycle of AI includes data processing, model development, model training, model management & testing, model deployment & service. AI development platforms design different service components for different users, who play different roles in the full lifecycle of AI. For example, Modelarts defines application engineers, industry experts, data scientists, algorithm experts, IT engineers, etc. It is also worth mentioning that the application of the big model is becoming more and more ecological integrity, including automated deployment, data collection, and so on.

#### 4.2.5 Training/Inference Acceleration in System Level

For big models, its training is too time-consuming, which prolongs the critical development cycle of the model and brings enormous costs. Similarly, high latency in big model inference has emerged as a barrier to big model applications, especially those real-time scenarios. Accelerating the model training and inference is a pivotal issue in LSICS construction that has yet to be answered. Some model design methods and model miniaturization technologies aside, the acceleration aim is not easily reconcilable in LSICS level. This section, we list some feasible approaches for this issue, which can accelerate the big model training and inference to a certain extent.

##### **(1) parallelism on multiple machines**

Experience shows that parallelism on multiple machines/GPUs will quickly accelerate the training/inference efficiency when the speedup ratio is high. Nowadays, deep learning frameworks promote training/inference acceleration by making all kinds of parallel (data parallel, model parallel, pipeline parallel, and hybrid parallel) easily accessible for users. This solution will not bring lower costs, but low latency and high throughput, which makes real-time model inference more accessible.

##### **2) load balancing and hardware optimization**

Given that an LSICS may have various of bottlenecks, it is necessary to take load balancing into consideration by using all kinds of strategies and algorithms. As discussed in Section 4.2.3, network or storage are the most common bottlenecks in LSICS. In this way, we can avoid some of these problems by adding or changing hardware or network topology, which depends on advances in hardware technology. Other hardware optimizations include GPU memory optimization, memory communication optimization, etc.

##### **3) communication optimization**

Apart from the hardware, the communication library is significant for parallelism on multiple machines. NCCL is short for NVIDIA Collective Communications Library, which provides inter-GPU communication primitives that are topology-aware and easily integrated into applications. Taking NCCL as an example, the time consuming of each all-gather operation in big model training reduced from 12 seconds to 2 seconds when NCCL V2.8 replaces NCCL V2.7 in an LSICS with 448 A100 GPUs. Efficient communication libraries make better utilization of bandwidth and reduce communication costs. The awareness of the importance of communication libraries, domestic AI chip vendors provide their own communication libraries, such as Huawei Collective Communication Library.

##### **4) operator library optimization**

In deep learning, some critical and time-consuming operators are usually optimized. Operator fusion combines multiple computing units into one computing core, which reduces the transfer of intermediate data and saves computing time. The corresponding hardware vendors generally provide operator development tools to optimize according to the situation. Some deep learning frameworks also support the operator library optimization, which improves the flexibility of the framework. For example, operator fusion is a way to improve performance by merging one operator into a different operator so that they are executed together without requiring a roundtrip to memory. In Nvidia products, cuda optimization is also an important way to achieve the acceleration aim.

### 5) training/inference tools change or optimization

As discussed in Section 4.2.4, the effectiveness of different deep learning frameworks is different for different tasks. For model inference, a large number of tools are available, such as TensorRT, TVM, Turbo Transformers, Mediapipe, OpenVINO, TF2, etc. This provides more choices for different task scenarios. Some of them are open-source, making it possible to adapt to specific applications.

Despite these solutions, further research is worth being conducted on this issue. What is more, for LSICS system-level optimization, local optimizations do not imply global optimization.

## 4.3 Discussion on LSICS

### 4.3.1 Limitation of Current LSICS

Advancement in LSICS processes has accelerated the process of big model research and application. With the increasing scale of the model and the higher requirements for model accuracy, big model developers realize that LSICS faces several vital challenges in dealing with the training of super large scale fine models. The limitations of current LSICS are attributed to the following aspects:

**1) The increase of model scale leads to a sharp increase in the amount of funds required for model training.** In fact, the size of typical pretrained big model increases by at least a factor of 10 every year: BERT-Large (2018) has 355M parameters, GPT-2 (early 2019) has 1.5B parameters, T5 (late 2019) has 11B parameters, GPT-3 (mid-2020) has 175B parameters. In 2021, Beijing Academy of Artificial Intelligence (BAAI) released Wudao 2.0 model with 1750B parameters. With the increase of model size, the expense of big model training increased dramatically, which became too expensive and time-consuming.

**2) The computing power of a single LSICS is becoming more and more difficult to meet the training needs.** In the post-Moore era, the progress of the sizes of language models clearly outpaces the growth of GPU memory. Big model training is a considerable task difficult to segment into a series of small non-interfering tasks at present. However, there is an upper limit on the size of a single computing cluster. So, the computing power of a single LSICS is brutal to meet all training needs of a big model. Primarily a single LSICS takes too much time for the training of vast size models.

**3) LSICS efficiency needs to be improved.** Although computing power is insufficient, LSICS is often used inefficiently in big model training for all kinds of reasons, which is a colossal waste. However, this problem still has not been solved satisfactorily for the imperfect of AI development platforms.

### 4.3.2 The Trend and Future of LSICS

Nowadays, LSICS is under rapid development with the increasing demand for computing power. The development of LSICS allows us to see some apparent trends of LSICS. In this paper, we investigate some trends of LSICS, which are listed in the following.

- AI-specific storage is crucial for big model training, which may break the storage bottlenecks. AI-specific storage aims at solving particular problems in big model training scenarios, such as “small file problem”.
- AI accelerator cards change from universal to specific, achieving better acceleration. AI chips for specific models may appear in the future.
- Remote LSICS collaboration has become an important research topic, aiming at assembling different LSICS to get a larger computing power cluster.
- In the future, there will be different types of AI accelerator cards provided by different vendors. Using heterogeneous GPU for collaborative computing still needs to be continued.

Furthermore, we insist that LSICS will become a critical infrastructure of the smart era in the near future. In the next decade, LSICS will make great strides.

#### 1) Some important theories may be broken

Shannon’s law, Moore’s law, and Von Neumann architecture are the most important theories of computing power in this era. However, these laws may be broken by the advance in technology to meet the current strong demand.

#### 2) LSICS should be cheap and more accessible for the whole society

On the one hand, advances in hardware technology will reduce cost. On the other hand, 5G technology and chip technologies will make LSICS more accessible for all kinds of applications. This will benefit the development and application of AI.

#### 3) LSICS development will be more connected with AI development

LSICS development and AI development will be mutual promotion. Customized computing power may be applied for specific model training tasks.

## 5 Parallel Training System

*Authors: Jiaao He, Weicheng Xue, Zixuan Ma, Jidong Zhai<sup>✉</sup>*

As the parameter scale and complexity of intelligence models growing rapidly, the computing power needed for model training also increases significantly. Except enlarging the scale of computational system, investigating method such as parallel support for big model training is another solution to accelerate the training process with limited computing resource. In this part, We intend to introduce the system and parallel support for large-scale model training from following perceptions.

- In Section 5.1, we summary the general trend of the development of model training systems from several different aspects.
- In Section 5.2, we introduce state-of-the-art systems of model training, including training frameworks, programming models and distributed training systems.
- In Section 5.3, we discuss several potential research directions that are worth studying in the near future.

### 5.1 Scope of Training System

**From Hardware to Software** Machine learning models especially deep learning models are compute-intensive, and the computational needs of deep learning are rapidly scaling, requiring more computational power [214]. CPUs are usually relatively slow when dealing with intensive deep learning workloads [215]. The GPU, which has a lot of CUDA cores and Tensor cores, are widely used to address such an issue. However, Google regarded the GPU as a general solution for machine learning training, so they developed its own specific AI architecture called TPU using systolic array in order to run heavy deep learning workloads more efficiently. Besides, NPU is a specialized circuit that can be used to execute deep learning applications, as NPU is an option of GPU for deep learning training but runs much faster than the GPU. Berggren et al. [216] presented a roadmap for emerging hardware technologies that can be beneficial to machine learning, which addresses different kinds of challenges as well as opportunities ranging from different subdomains, including device optimization, material selection, and system integration.

Obviously, only depending on the hardware development to improve deep learning training is not enough. New kinds of deep learning frameworks and libraries are created to make the training more distributed, faster, more efficient, and less expensive both computationally and economically. Redesign of deep learning models, optimizers, and better data preprocessing techniques are used to promote training to become faster and more stable [217, 218, 219]. Hadjis et al. [217] developed a simple but efficient hyperparameter optimizer by picking the highest degree of asynchrony for asynchronous training. Their approach can choose a near-optimal point in the searching space and outperforms the Bayesian approach. Yuan et al. [218] developed a new distributed training framework based upon a split, broadcast, and partial-value abstraction, which makes data parallelism and model parallelism easier, and improves the training efficiency compared to existing work including ZERO-DP [220] and Megatron-LM [201]. Cheng et al. [219] proposed DLBooster to improve the running efficiency of deploying deep learning applications on GPU clusters with the redesign of data preprocessing and scheduling.

**From Single-device to Large Scale** Big models are attaining more attention as improvements in pre-training may transfer advantages to downstream tasks [1], although the performance of downstream tasks may saturate at some points [221]. There are mainly two obstacles to adopting big models. The first obstacle to training a big model is that a small number of devices may not be able to hold a whole model, for example, a transformer [25] or a large language model [222]. The second obstacle is that the training may cost an incredibly long time for a small number of devices, let alone a single one [215]. Due to the two obstacles mentioned earlier, it is necessary to train big models across a relatively large number of devices and distribute the workload. Different levels of parallel parallelism need to be exposed and communication costs across devices need to be minimized [223].

**From General to Specific** Previously, the development of chips favored general purpose processing units such as CPU. The Moore’s law tells that by simply adding more transistors on a chip, we can obtain higher compute capability in a simple way. However, the Moore’s law turns out to be gradually invalid due to the saturation of the technique and heavy economy cost, and the slow down of the Moore’s law has pushed the computing processors more specialised [224]. Deep learning has higher requirements, including higher compute capability, more parallelism, more efficient energy usage, and fewer significant digits of precision. These demands have driven the development of various AI chips, including GPUs, FPGAs, ASICs, and brain-like chips, which can mimic the human neural network [215]. These different AI

---

Jidong Zhai (zhaijidong@tsinghua.edu.cn) is the corresponding author of Section 5.

chips stress different kinds of tasks. FPGAs are usually used for inferences, ASICs are usually used for scenarios that require a high efficiency (higher compute power per watt), and AI chips that can mimic human’s brain activities. Many vendors have joined the race of specialized chips, for example Microsoft [225], Huawei, and Baidu [226].

**From Enabling Training to Extreme Efficiency** TensorFlow and PyTorch provide some capabilities to train models. However, they may not be very efficient, and these parallel capabilities are still difficult to use, and the performance is hard to scale. Training on large-scale datasets usually consumes much time and requires very expensive accelerators. Thus, improving the training efficiency for big models becomes very important. From the perspective of distributed training design, reducing the communication cost across multiple GPUs (since many large-scale trainings are memory bound instead of computing bound), exposing more degrees of parallelism automatically, and enabling larger-scale training using fewer numbers accelerators are of significant importance. However, redesign of algorithms or developing more computationally efficient methods is another possible solution [227,228]. So et al. [227] developed an evolved transformer with fewer parameters that can achieve the same quality as the original transformer. Hernandez et al. [228] pointed out that hardware and algorithmic efficiency gains can be multiplied, and neither factor is negligible. Both improvements in data efficiency (needing fewer epochs) and reductions in the number of FLOPs required per epoch play essential roles in the overall algorithmic efficiency gains. These improvements include sparsity, batch normalization, residual connections, architecture search, and appropriate scaling. It should be noted that algorithmic efficiency improvements are usually underestimated for scaling, but are crucial to the overall performance.

## 5.2 State-of-the-art Systems for Model Training

### 5.2.1 Training Frameworks and Programming Models

Training deep learning models involves various operations on tensors, and the amount of computation may be enormous. Therefore, it is straightforward that these operations should be implemented with high-performance libraries, e.g., Intel MKL, and performed by high-performance devices, e.g., GPUs [229,230]. Besides, due to the fast-evolving model structures, user-friendliness is greatly appreciated by the AI community. Features, such as support of auto-differentiation, python bindings, and intuitive debugging method, are supported by modern NN training frameworks.

Caffe [231] is one of the earliest frameworks for Deep Learning training tasks, with automatic differentiation and GPU supported. It provides a C++ machine learning library with Python and MATLAB bindings. Models are defined and trained using built-in API. Caffe is good for general purpose convolutional neural networks but may not be a good option for recurrent networks due to insufficient relevant documentation.

To better express various model structures and operations, Google developed TensorFlow [232], a framework that networks are represented as data flow directed acyclic graphs (DAGs). TensorFlow has been applied in many areas, including natural language processing, computer vision, physics-informed AI applications, etc. However, there are constant complaints about its descriptive programming style and difficulties in debugging.

Baidu proposed PaddlePaddle which is used for multi-level distributed training [233]. PaddlePaddle can support ultra-large data training easily across different architectures, including server, mobile, and edges.

PyTorch was proposed by Facebook [234]. PyTorch is based on dynamic computational graphs, so it is more flexible for code implementation and easier for debugging. As one of the most user-friendly frameworks, PyTorch has gained tremendous popularity in industry and academia. However, its dynamicity feature disables many optimizations, e.g., kernel fusion and computation graph transformation. A comparison of interfaces that the frameworks provide to model developers is seen in Table 8. Caffe regards model structure as configurations of a training task, defined in `prototxt` files. TensorFlow introduces Python to make coding easier, while it has to compile the model, making it impossible to have variable model structure in training, and introduces extra burden when debugging. PyTorch allows the training process to be expressed in the most intuitive style. NN operations are performed at the location they are in the code.

JAX, which was proposed by Google, can convert a native Python and Numpy function to a function that returns the original function’s gradient and also provides just-in-time compilation for function transformation [235]. JAX can easily generate high-performance code for various machine learning algorithms across different platforms. JAX is still an active research project, not an official Google product.

MindSpore was developed by Huawei to enable data scientists to easily design and efficiently execute their deep learning applications in device, edge, and cloud scenarios [236]. MindSpore can automatically choose a strategy to achieve automatic model parallelization by using flexible policies and cost models. MindSpore supports both graph-level and operator-level automatic differentiation.

OneFlow is another framework designed for distributed training. It is based upon a split, broadcast, and partial-value abstraction and an actor model [218]. OneFlow enables much easier implementations of data parallelism and model parallelism than existing distributed training libraries, including TensorFlow, PyTorch, and Megatron-LM. In addition, the training efficiency using OneFlow can also outperform the existing libraries.

Table 8. Comparison of Framework Interfaces for Model Developers

Framework	Model Definition	Training
	In a prototxt file.	
Caffe	<pre> 1 layer { 2   type: "Data" 3   top: "data" 4   top: "label" 5   data_param { 6     source: "input_leveldb" 7     batch_size: 64 8   } 9 } 10 layer { 11  type: "InnerProduct" 12  bottom: "data" 13  top: "ip" 14  inner_product_param { 15    num_output: 2 16  } 17 } 18 layer { 19  type: "SoftmaxWithLoss" 20  bottom: "ip" 21  bottom: "label" 22  top: "loss" 23 }</pre>	<p>Optimizers are defined in a solver.prototxt file.</p> <pre> 1 base_lr: 0.001 2 momentum: 0.9 3 momentum2: 0.999 4 lr_policy: "fixed" 5 type: "Adam"</pre> <p>And train in a shell script.</p> <pre> 1 caffe train --solver=solver.prototxt \ 2   examples.prototxt</pre>
TensorFlow	<pre> 1 model = tf.keras.Sequential([ 2   tf.keras.layers.Flatten(input_shape=(28, 28)), 3   tf.keras.layers.Dense(128, activation='relu'), 4   tf.keras.layers.Dense(10) 5 ]) 6 Loss = SparseCategoricalCrossentropy 7 model.compile(optimizer='adam', 8   loss=Loss(from_logits=True), 9   metrics=['accuracy'])</pre>	<pre> 1 optimizer = tf.keras.optimizers.Adam() 2 for images, labels in train_ds: 3   with tf.GradientTape() as tape: 4     predictions = model(images, training=True) 5     loss = loss_object(labels, predictions) 6     gradients = tape.gradient(loss, 7       model.trainable_variables) 8     optimizer.apply_gradients(zip(gradients, 9       model.trainable_variables))</pre>
PyTorch	<pre> 1 class MLP(nn.Module): 2   def __init__(self): 3     super(MLP, self).__init__() 4     self.layers = nn.Sequential( 5       nn.Linear(784, 100), 6       nn.ReLU(), 7       nn.Linear(100, 10) 8     ) 9 10  def forward(self, x): 11    x = x.view(x.size(0), -1) 12    x = self.layers(x) 13    return x</pre>	<pre> 1 model = MLP() 2 optimizer = torch.optim.Adam( 3   model.parameters(), lr=0.001) 4 loss_fn = nn.CrossEntropyLoss() 5 for images, labels in train_loader: 6   optimizer.zero_grad() 7   outputs = model(images) 8   loss = loss_fn(outputs, labels) 9   loss.backward() 10  optimizer.step()</pre>

## 5.2.2 Distributed Training Systems

As training frameworks provide an excellent programming interface and capability to utilize different accelerators, it remains a challenge to train models in distributed systems. However, as there are more and more training data, and models are growing larger, it is inevitable that huge clusters have to work as a whole system to train a model. Coordinating multiple devices with high efficiency and good scalability becomes the key to current training systems. Numerous different ways of parallelism are proposed. Below, we categorize them according to their core parallelism method.

**Data Parallelism** Parameter server (PS) [237] is first proposed to train a model using multiple devices. The model is maintained by a centralized service, namely the PS. Workers pull a model from the PS, perform forward and backward computation with their locally loaded training data, and then push the gradients back to the PS to update the model. PS is used as the default distributed solution in TensorFlow [232]. It provides flexibility in the number of workers, as RPC [238] is commonly used for communication between workers and the PS. However, as a centralized system, network contention and gradient aggregation becomes the performance bottleneck and stop PS from scaling up to larger clusters.

Data parallelism is defined as each worker training the same model with different data. For example, when the PS works in a synchronous way, such that the model is updated after each worker finishes one mini-batch and waits for

the updated model, it is a typical set of data parallelism. Meanwhile, data parallelism can be achieved more efficiently using collective communication methods, e.g., Ring Allreduce introduced by the HPC community. Horovod [239] is developed as a plugin to TensorFlow and replaces the PS by all-reduce operation on gradients. As a result, the training system becomes decentralized and homogeneous, and the scalability is greatly improved.

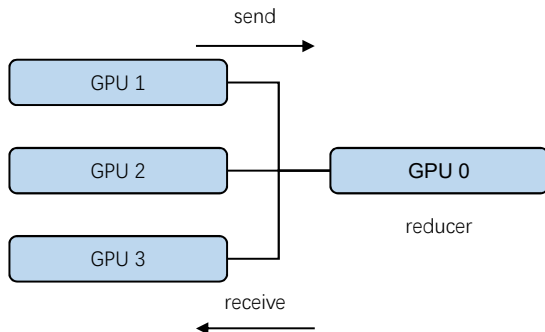

Fig. 8. Overview of Parameter Server.

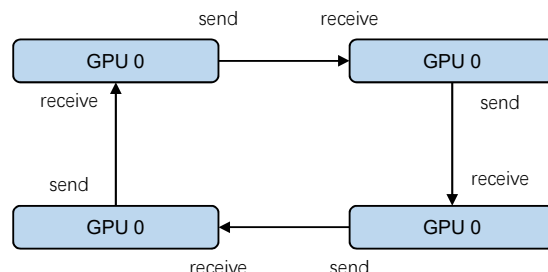

Fig. 9. Overview of Ring All-Reduce.

However, when scaling to an extremely large scale, all-reduce still faces the challenge of being inefficient. Co-design of hierarchical all-reduce and model optimizer makes training possible in such scale [240, 241, 242, 243]. Besides, asynchronous data parallel training approaches [244, 245, 246] can handle heterogeneity in large systems for better training throughput.

As a more general system of data parallelism, BytePS [247] regard PS as a service that can be distributed across workers. Both typical PS and all-reduce are regarded as a special form of the general PS architecture.

ZerO optimizer [220] instantiates such approach by splitting up optimizer states, gradients, and even model parameters onto all workers to reduce per-device memory footprint. Furthermore, data can be off-loaded from GPU memory to host memory to accommodate more prominent models in a given system [248]. Even disks are capable of such job [249], and tera-byte level models can be stored in a single machine.

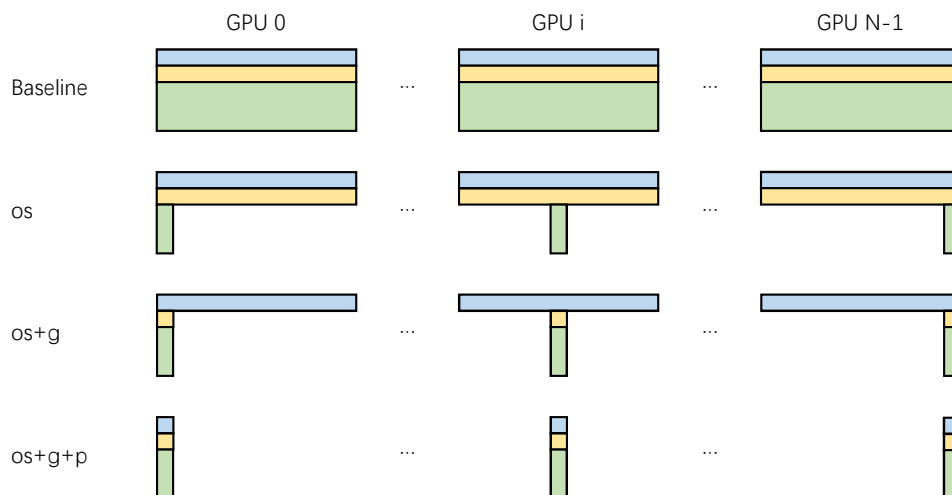

Fig. 10. Per-device memory consumption of model states with ZerO's different optimization levels.

**Model Parallelism** Different from data parallelism that the same model is duplicated across all workers, the model is split up in model parallelism. In typical model parallelism, tensors of parameters are split along certain dimensions. Training data and feature maps are split or duplicated accordingly and routed to places they are needed by the system designed by experts. This approach is first introduced as a trick [250] to accelerate training of fully connected layers where synchronizing gradients of the large parameter matrices consumes much more time than re-arranging feature maps.

Model parallelism introduces a much larger space of partitioning tensors than data parallelism, which is critical to training performance. FlexFlow [251] introduces a system on tensor partition representation to generate optimal tensor partition strategy. Tofu [252] adopts a different approach that concentrates on splitting operators rather than tensors. Performance models and searching techniques are keys to these systems, requiring knowledge of the system and the model. They show effectiveness on smaller static models, while the searching process may be time-consuming.

Mesh-TensorFlow [253] is a semi-automatic model parallelism solution for TensorFlow and TPU systems. It maps dimensions of certain tensors to a device mesh and automatically induces partition strategies for intermediate tensors. Furthermore, GShard [254] and GSPMD [255] discusses partitioning interface, searching space, and performance tuning techniques based on model parallelism.

Megatron-LM [201] uses a more manual approach targeting on specific transformer models. Experts design specific tensor partition strategies to partition each transformer block to achieve high performance. This system becomes a widely-used framework for transformers and successfully trains a trillion-scale model on 3,072 NVIDIA GPUs.

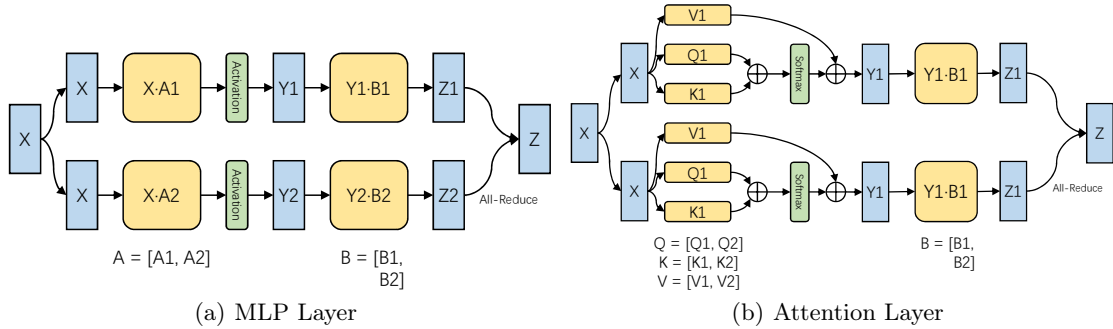

Fig. 11. Blocks of Transformer with Model Parallelism in Megatron-LM.

Inspired by distributed GeMM algorithms used in traditional HPC applications, Colossal-AI [256] adopts several algorithms that minimize communication by 2D [257], 2.5D [258], or 3D [259] distributed algorithm. Beyond model and data parallelism, the tensor program is treated as multiple large GeMM operations and partitioned according to heuristics.

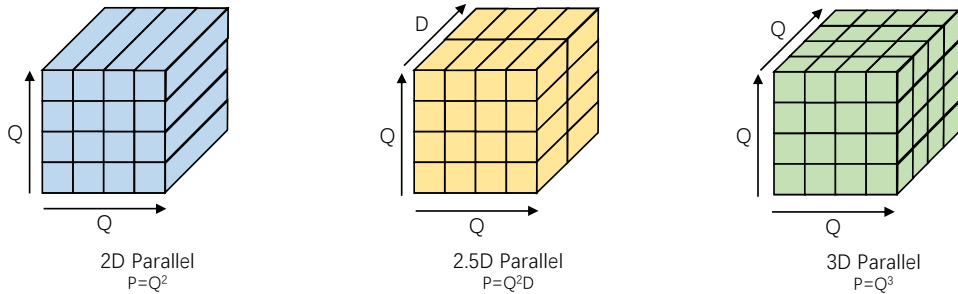
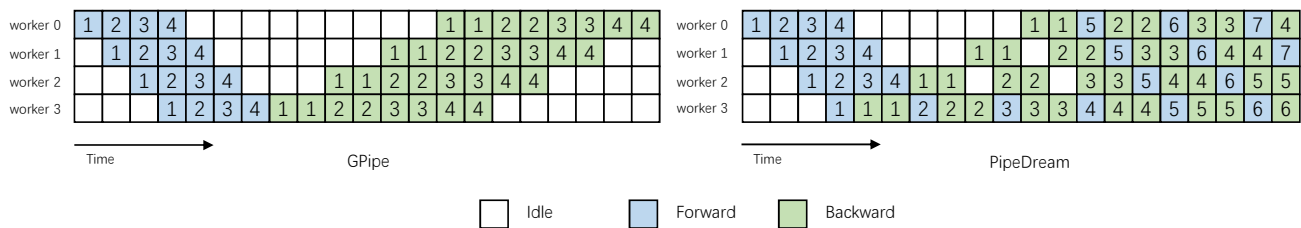

Fig. 12. An example of the 2D, 2.5D, and 3D parallel matrix multiplication

**Pipeline Parallelism** Due to the layer-by-layer nature of the NN structure, the computation process can be divided into several stages and processed in a pipeline on different devices. GPipe [260] first introduces such a pipeline with two newly introduced concepts, global and local batch. A global batch consists of multiple local batches, and local batches flow through the pipeline one by one. Intermediate feature maps are sent across adjacent workers of the pipeline. There is no need to synchronize gradients. Larger models can be stored in the system, as there are no duplicated model parameters.

GPipe's pipeline introduces bubbles due to its startup overhead in every global batch, making workers idle and lowering its efficiency. PipeDream [261] is designed to address the issue by a more tight schedule that eliminates bubbles with asynchronous model updating. It also introduces a dynamic programming-based approach to split the model into more even stages, so that the pipeline can be more efficient. PipeDream-2bw [262] enables synchronous training with the same bubble-free pipeline schedule.





**Fig. 13.** An example of pipeline with GPipe and PipeDream with 4 workers.

To maintain backward on different versions of parameters, PipeDream suffers from huge memory consumption. PipeMare [263] reduces its memory footprint by a fine-grained schedule.

Splitting the pipeline into multiple stages can be hard when the model is shallow and there are many workers. DApple [264] hybrids pipeline parallelism with data parallelism in a flexible way to scale pipeline parallelism to more nodes.

Pipeline parallelism can also be applied on different scales. TeraPipe [265] explores pipeline in token level in transformer models.

**Expert Parallelism** Mixture-of-expert(MoE) is a newly evolving structure for extremely large models beyond trillion scale. Instead of increasing the size of dense layers, which involves too much computation overhead, multiple smaller dense layers are regarded as experts, and only a few experts that fit a specific input are activated to process it. This reduces the amount of computation and makes training and inference of trillion-scale models possible.

To parallelize MoE models, GShard [254, 255] introduces expert parallelism. Experts are located on different workers. Outside MoE layers where contains the most parameters of a model, the input sequences are processed by data parallelism. In MoE layers, input is sent to its desired expert by the system, and sent back after being processed. This both saves memory to store the model and reduces overhead to process the sequences. However, load imbalance makes its computation inefficient. Therefore, soft and hard limits are both applied in this system to enforce load balance.

BASE Layers [266] uses a best-matching algorithm to achieve total load balance. Unfortunately, the matching algorithm is less efficient.

FastMoE [267] is a flexible system to train various MoE models using expert parallelism. It abstracts the structure of MoE models, and includes GShard and BASELayers' solutions as a specific gate network that decides expert selection.

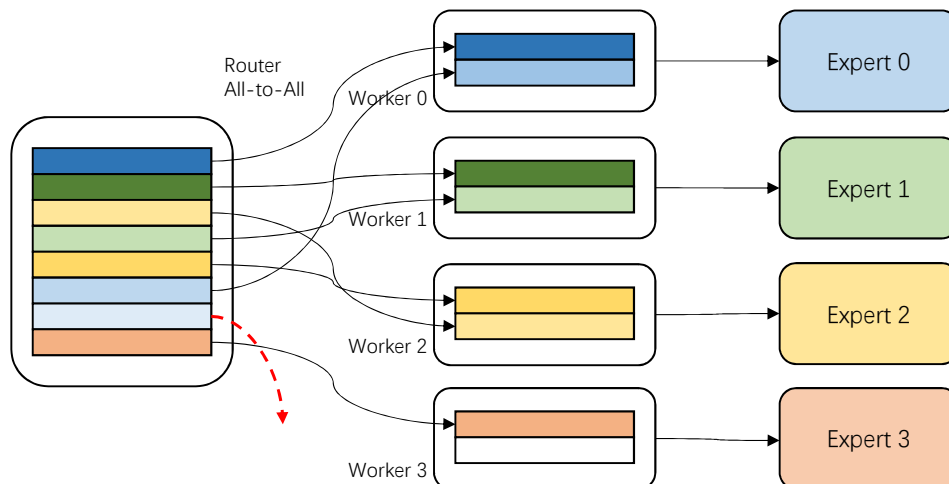

**Fig. 14.** An example of pipeline with GPipe and PipeDream with 4 workers.

**Systems for Trillion Parameters** Training trillion-scale models requires strong computation power that only top supercomputers in the world can provide. Parallel system design is complex and challenging at such a scale.

Megatron-LM [201] hybrids data, model, and pipeline parallelism for its ultimately large model. It trains a model with one trillion parameters on 3,072 NVIDIA A100 GPUs (384 DGX A100 nodes). However, it is estimated to train for 84 days, as it is dense.

Google trains a 0.6 trillion model with GShard [254] in 4 days with 2,048 TPUs by expert parallelism. Thanks to the sparse model structure and AI-targeted hardware design, it takes much less time to train such a large model. Moreover, the size of the model grows to 1.6 trillion in SwitchTransformer [268], which is based on the same system.

BAAI releases an even larger model, WuDao, with 1.75 trillion parameters. This model is based on a brand new Sunway supercomputer. The underlying training system, BaGuaLu [27], is even able to train 170 trillion parameter models, pushing the limit to 2 orders of magnitude larger. This system hybrids expert parallelism with data parallelism, and with specific HPC design, it is able to achieve exascale computation throughput.

### 5.2.3 Summary for Current State-of-the-art

Training frameworks provide a friendly programming interface for model developers, and enable efficient training on various accelerators. A great number of techniques are invented to train larger models on larger systems, including different parallelisms and optimizations. Co-design of hardware, system, and model is vital to explore extremely large models with high performance. It remains an open question: What is the best way to train models with the highest performance in different platforms.

## 5.3 Future Directions

Parallel training support for big models is still under fast development. With new big models constantly emerging, parallel techniques are demanded to support them, and enable exploring models at a larger scale. The system community is also seeking more opportunities from both hardware and software. We present three hot research topics that may gain more popularity in the near future.

### 5.3.1 Next-generation Training Framework

Flexibility for programming and good performance has been contradictory in current training frameworks, as performance optimizations commonly require well-formed tensor program representation, which is not applaudable by model programmers. Next-generation training frameworks are expected to address the issue by better compilation techniques. JAX [235] adopts a Numpy-style frontend for better programmability, while an XLA computation graph is generated as backend. TorchScript [269] tries to compile PyTorch code with limited Python grammar. In the future, model programming systems may support more flexible Python expressions, and possess the ability to optimize them.

From the view of distributed programming, it has always been a hard problem to run a program of a single node in distributed systems. The chances are that DNN models with tensors are more regular than traditional programs, and can be parallelized from tensor dimensions. However, generating automatic and high-performance parallel strategies is challenging. Mesh-TensorFlow [253] and GSPMD [255] requires manual annotation on tensors to determine them. Colossal-AI [256] splits up tensors by heuristics from classic distributed GeMM algorithms, whereas there is not a general algorithm for other operators. It remains a hot topic to create distributed training framework that is both programmer-friendly and high-performance.

### 5.3.2 Mixed-precision Systems

It is found that the previously widely-used 64-bit double-precision float point numbers are too precise for AI models. Single precision of 32 bits, and even half-precision of 16 bits, is enough for many models. Considering the nature that the fewer bits the number has, the fewer transistors are placed on the chip. New floating-point formats are even proposed and supported by hardware to fill the gap between FP16 and FP32, such as TF32 from NVIDIA [270] and BF16 from Google [271]. There can be much more computation units with reduced chip size per unit. As a result, the throughput of the devices is significantly increased.

However, decreased precision introduces an uncertain effect on model quality, which requires a case-by-case study. In most occasions, only part of the model can be computed and stored using FP16, while others should remain FP32. Some parts may also be computed by FP32 but stored by FP16. Given specific hardware, using different precision may lead to a huge performance gap. Properly using different floating-point formats can greatly accelerate computation without hurting model quality. However, this requires sophisticated software support that does not present yet. The software should be able to identify precision the requirement of a given model, and adapt the fastest mixed-precision training strategy.

### 5.3.3 Domain-specific Systems

New hardware are targeted specifically at AI. As an early participant in the AI hardware industry, Huawei’s Ascend series AI accelerators introduce dedicated hardware for convolution networks. Google develops TPU [272] that concentrates on tensor computation with a specially designed matrix computation engine. As a general-purpose accelerator manufacturer, NVIDIA attaches Tensor Cores on newer generations of GP-GPUs for better tensor processing ability.

Besides single accelerators, inter-connection has also been a hot topic. Switch is given the function of parameter server with hardware support [273].

Beyond computation and communication hardware, they are composed together as supercomputers for large models. 2,048 TPUs are organized as a 3D torus with high bandwidth, as a TPU pod, with up to 100+ Peta-flops computation power. Pengcheng Cloudbrain is another specially designed AI supercomputer at exascale. Besides, many supercomputers have AI accelerators, e.g., TCUs on NVIDIA’s GPUs, achieving more than EFLOPs model training capability. There will definitely be larger and larger supercomputers for AI training. Their computation power will help push the frontier of large models.

Additionally, building such systems is costly. Supercomputers are commonly built by governments or large companies. As a new primary facility of academia, computation power is being intensively created to enable research and empower industry.

## 6 Big Language Model

*Authors: Yankai Lin<sup>\*</sup>, Xu Han<sup>\*</sup>, Zhenghao Liu<sup>\*</sup>, Ning Ding<sup>\*</sup>, Zhengyan Zhang, Shengding Hu, Yujia Qin, Chaojun Xiao, Zheni Zeng, Ganqu Cui, Weize Chen, Weilin Zhao, Yuan Yao, Peng Li, Zhiyuan Liu<sup>✉</sup>, Maosong Sun<sup>✉</sup>*

Human language characterizes and explain how humans use words to communicate their own ideas and feelings, in conversations, writing, and other media. To bridge the gap of interactions between machine and human language, NLP programs machine to cognize how humans acquire, produce, and understand language, and understand the relationship between linguistic utterances and the world [274]. Early symbolic-based or statistical NLP systems regard language processing as a complex sets of expert designed rules or statistical rules based machine learning algorithms. Later, with the development of deep learning, neural NLP [275] provides a novel perspective to language processing, that is, learning a good language representation to capture the linguistic and implicit world knowledge in and beyond the text. Recently, Big Language Models (BLMs) [26,18] become a new paradigm to learn universal language representation from large-scale unlabeled data. In this part, we intend to introduce BLMs’s training paradigm as well as their applications in various downstream NLP tasks, discuss several advances topics of big language models, and give some future directions of this research area.

- In Section 6.1, 6.2 and 6.3, we introduce several model training paradigms, involving neural language representation, language modeling as deep learning objectives and pre-training-then-fine-tuning.
- In Section 6.4, we introduce some common downstream tasks in NLP field, such as dialogue, text generation and machine translation.
- In Section 6.5 and 6.6, we discuss several newly developed research topics in NLP field and propose some valuable research directions.

### 6.1 Neural Language Representation

A good language representation should not only capture the linguistic knowledge in the text, such as lexical meanings, syntactic structures, semantic roles, but also the implicit world knowledge hiding beyond the text. With the development of deep learning, various neural models have been widely used to represent text, providing a flexible approach to mine this knowledge without complicating manual feature engineering. In this section, we introduce the typical neural language encoders. Formally, given the input text  $(x_1, x_2, \dots, x_L)$  with  $L$  tokens, where each token  $x_i \in \mathcal{V}$  is a character, sub-word or word [276], and  $\mathcal{V}$  is the vocabulary, the neural language encoder can be formulated as a text encoding function  $f_{enc}$ :

$$[\mathbf{h}_1, \mathbf{h}_2, \dots, \mathbf{h}_L] = f_{enc}(\mathbf{x}_1, \mathbf{x}_2, \dots, \mathbf{x}_L), \quad (1)$$

where  $\mathbf{x}_i$  and  $\mathbf{h}_i$  are the token embedding and the neural language representation for the token  $x_i$  respectively. Here,  $\mathbf{h}_i$  aims to capture the contextual information of  $x_i$  in the input text. Generally,  $f_{enc}$  consists of one or more building layers, which can be mainly divided into three categories according to the basic blocks of each layer: convolutional language encoders, recurrent language encoders and self-attention language encoders.

---

<sup>\*</sup>Yankai Lin, Xu Han, Zhenghao Liu and Ning Ding contribute equally.

<sup>✉</sup>Zhiyuan Liu (liuzy@tsinghua.edu.cn) and Maosong Sun (sms@tsinghua.edu.cn) are the corresponding authors of Section 6.

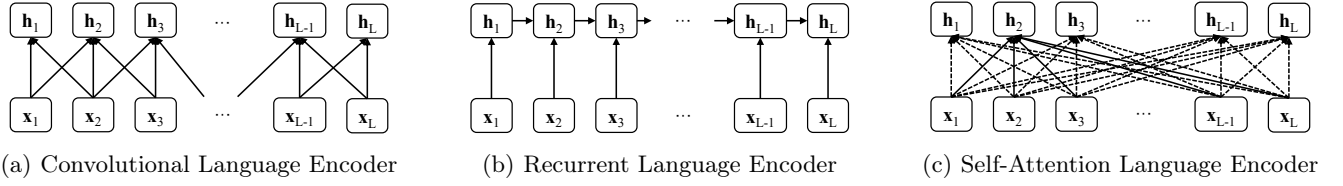

**Fig. 15.** Typical neural language encoders.

### 6.1.1 Convolutional Language Encoder

Convolutional language encoder is usually used to aggregate the local contextual information of a word within a neighbor window by convolution operations. As shown in Fig. 15(a), it can be formulated as:

$$\mathbf{h}_i = \text{CNN}(\mathbf{x}_{i-l}, \mathbf{x}_{i-l+1}, \dots, \mathbf{x}_{i+l}) = \text{CNN}(\mathbf{x}_{i-l:i+l}) \quad (2)$$

where  $\mathbf{x}_{i-l:i+l}$  is the concatenation of token embeddings from the token  $x_{i-l}$  to  $x_{i+l}$ , and  $l$  is the window size,  $\text{CNN}(\cdot)$  is the convolutional function containing a convolutional matrix, a bias vector, and an activation function. It indicates the representation of the token  $x_i$  is only related to the words inside the window, and thus aggregates the local contextual information. In practice, such convolutional operation is usually in the multi-channel form [277, 278, 279], where different channels have different window sizes, aiming to aggregate different levels of local information.

### 6.1.2 Recurrent Language Encoder

Recurrent language encoder is usually used to model the short-term and long-term dependencies of the input text by recurrent operations. As shown in Fig. 15(b), it can be formulated as:

$$\mathbf{h}_i = \text{RNN}(\mathbf{h}_{i-1}, \mathbf{x}_i), \quad (3)$$

where  $\text{RNN}(\cdot)$  is the recurrent function (unit). The most widely used implementations of  $\text{RNN}(\cdot)$  are long short-term memory (LSTM) [280] and gated recurrent unit (GRU) [281]. By performing recurrent operation token-by-token, the representation of the token  $x_i$  thus can capture the historical information of those previous tokens. In practice, such recurrent function is usually set as bi-directional form (i.e., bi-directional LSTMs or bi-directional GRUs), aiming to collect information from both sides of a token. Although recurrent language encoders can capture the long-term dependency better to some extent compared with the convolutional language encoder, they are still far from perfect.

### 6.1.3 Self-Attention Language Encoder

Self-attention language encoder provides a more flexible approach to model the input text by the self-attention mechanism. Especially, it assumes the representation of a token is related to all tokens in the text and uses the self-attention mechanism to learn the relation between every two tokens. As shown in Fig. 15(c), it can be formulated as:

$$\mathbf{h}_i = g(\mathbf{x}_1, \mathbf{x}_2, \dots, \mathbf{x}_L) = \sum_j \alpha_{ij} \mathbf{x}_j, \quad (4)$$

where  $\alpha_{ij}$  is the attention weight calculated by self-attention mechanism, indicating the relation between  $x_i$  and  $x_j$ . With such position-independent relation modeling, self-attention language encoder thus can better consider both short-term and long-term dependencies in the text than the convolutional and recurrent language encoder.

The most widely-used self-attention language encoder is the Transformer [25], of which the basic block consists of a multi-head self-attention layer and a position-wise feed-forward layer. When stacking the Transformer block into a deep one, residual connection [13] and layer normalization [282] are added between blocks to make it easier to train. The details of these layers are introduced as follows:

**Attention Layer.** Self-attention layers are the key to the success of Transformer. Formally, the self-attention layer regards the input tokens  $\{x_1, x_2, \dots, x_L\}$  as the query set  $\mathcal{Q} = \{\mathbf{q}_1, \dots, \mathbf{q}_L\}$ , the key set  $\mathcal{K} = \{\mathbf{k}_1, \dots, \mathbf{k}_L\}$ , the value set  $\mathcal{V} = \{\mathbf{v}_1, \dots, \mathbf{v}_L\}$ . Hence, the query vector  $\mathbf{q}_i$ , the key vector  $\mathbf{k}_i$ , and the value vector  $\mathbf{v}_i$  are calculated as:

$$\mathbf{q}_i = \mathbf{x}_i \mathbf{W}^Q, \quad \mathbf{k}_i = \mathbf{x}_i \mathbf{W}^K, \quad \mathbf{v}_i = \mathbf{x}_i \mathbf{W}^V, \quad (5)$$

where  $\mathbf{W}^Q$ ,  $\mathbf{W}^K$ ,  $\mathbf{W}^V$  are respectively used to project the input  $\mathcal{X} = \{x_1, x_2, \dots, x_L\}$  into the feature space of query, key and value.

The scaled dot-product attention is then defined as:

$$\{\mathbf{h}_1, \dots, \mathbf{h}_n\} = \text{Self-ATT}(\mathbf{Q}, \mathbf{K}, \mathbf{V}) = \text{softmax}\left(\frac{\mathbf{Q}\mathbf{K}^T}{\sqrt{d_k}}\right)\mathbf{V}, \quad (6)$$

where  $d_k$  is the dimension of input token embeddings and  $\frac{1}{\sqrt{d_k}}$  is the scaling factor. The calculation of the scaled dot-product attention can be viewed as (1) first obtaining the weight  $\alpha_{ij}$  to indicate how attended the query vector  $\mathbf{q}_i$  against the key vector  $\mathbf{k}_j$ , i.e., the relation between  $x_i$  and  $x_j$ , through the scaled dot-product multiplication; and then (2) calculating the weighted mean of value vectors as the final representation.

Rather than directly using the vanilla scaled dot-product attention, the Transformer applies a multi-head attention layer defined as follows:

$$\mathbf{H} = \text{MH-ATT}(\mathbf{Q}, \mathbf{K}, \mathbf{V}) = \text{Concat}(\mathbf{H}_1, \dots, \mathbf{H}_h)\mathbf{W}^O, \mathbf{H}_i = \text{ATT}(\mathbf{X}\mathbf{W}_i^Q, \mathbf{X}\mathbf{W}_i^K, \mathbf{X}\mathbf{W}_i^V), \quad (7)$$

where  $h$  is the number of attention heads, and  $\mathbf{W}_i^Q$ ,  $\mathbf{W}_i^K$ ,  $\mathbf{W}_i^V$  are the corresponding projection matrices to project the input  $\mathbf{X}$  into the feature space of the  $i$ -th attention head. Finally, the multi-head attention layer applies  $\mathbf{W}^O$  to project the concatenation of the output of all attention heads into the final output representation.

**Position-Wise Feed-Forward Layer.** The Transformer block contains a position-wise feed-forward layer (FFN) after multi-head attention layers, which is defined as

$$\bar{\mathbf{H}} = \text{FFN}(\mathbf{H}) = \sigma(\mathbf{H}\mathbf{W}_1 + \mathbf{b}_1)\mathbf{W}_2 + \mathbf{b}_2, \quad (8)$$

where  $\sigma(\cdot)$  is the activation function (usually the ReLU [283] or GeLU [284] function).  $\mathbf{W}_1$ ,  $\mathbf{b}_1$ ,  $\mathbf{W}_2$ ,  $\mathbf{b}_2$  are the learnable parameters for projection of FFN layers.  $\bar{\mathbf{H}}$  is the final output of the feed-forward layer.

**Residual Connection and Normalization.** Transformer also applies residual connection and layer normalization to make the deep Transformer easier to train. Formally, let  $f(\cdot)$  indicate the combination of multi-head attention and position-wise feed-forward layers, the residual connection and normalization layer is defined as:

$$\mathbf{H} = \text{A\&N}(\mathbf{X}) = \text{LayerNorm}(f(\mathbf{X}) + \mathbf{X}), \quad (9)$$

where  $\text{LayerNorm}(\cdot)$  denotes the layer normalization operation.

Besides the typical Transformer architecture, some other works like recursive neural network [285] and TreeLSTM [286, 287] utilize a pre-defined tree or graph structure between tokens, such as the syntactic structure or semantic relation, to learn the language representation. These works can be viewed as a special form of self-attention language encoder, which gives constraints of the self-attention weight calculation.

## 6.2 Language Modeling as Deep Learning Objectives

Next, how to learn a good language representation becomes an important problem. A straightforward solution is to direct train the language encoder with the labeled data in the downstream task. However, building large-scale labeled datasets is time-consuming and even impossible for most NLP tasks. On the other hand, language modeling, the task of predicting what character/sub-word/word comes next, provides a feasible way to learn how to encode language from large-scale unlabeled corpora, which are easier to collect on the web. In this section, we first introduce several typical language modeling objectives in deep learning, including encoder-based, decoder-based and encoder-decoder-based language modelings.

### 6.2.1 Encoder-based Language Model

The encoder-based language model usually utilizes a bidirectional text encoder to model the probability of the input text. The masked language model (MLM) loss [18] is the most widely-used objective for the encoder-based language model. As shown in the left of Fig. 16(a), MLM first masks out part of the tokens in the input text and then trains the model to predict the masked tokens according to the other unmasked tokens. Formally, given text  $\mathcal{X} = (x_1, x_2, \dots, x_L)$  with  $L$  tokens, the masked text is denoted as  $\hat{\mathcal{X}} = (x_1, [mask], x_3, \dots, [mask], x_L)$  and the learning objective of MLM is defined as:

$$\mathcal{L}_{MLM} = \sum_{x_i \in m(\mathcal{X})} \log p(x_i | \mathcal{X} \setminus m(\mathcal{X})), \quad (10)$$

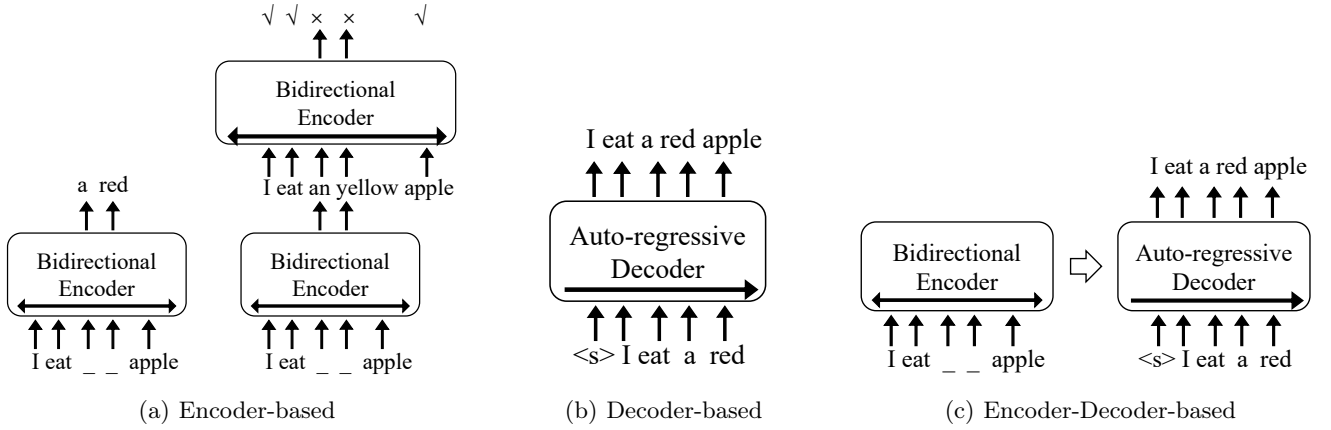

**Fig. 16.** The architectures of various language modeling objectives. We take the masked form as an example, where “\_” indicates a masked token.

where  $m(\mathcal{X})$  denotes the masked token set and  $\mathcal{X} \setminus m(\mathcal{X})$  denotes the unmasked token set. Here,  $p(x_i | \mathcal{X} \setminus m(\mathcal{X}))$  is usually modeled with a bidirectional encoder, which sets  $\mathcal{X}$  as the input text and outputs the probabilities of each masked token.

However, MLM generally requires large amounts of computations since its modeling objective only covers part of the input text (the masked tokens, usually 10-30% of the input text). To address this problem, replaced language model (a.k.a, replaced token detection) [288] proposes to predict whether each token in the corrupted input was replaced by a generator sample or not instead of predicting the masked token. As shown in the right of Fig. 16(a), its learning objective is defined as:

$$\mathcal{L}_{RLM} = \sum_{i=1}^L \log p(y_i | \bar{\mathcal{X}}), \quad (11)$$

where  $\bar{\mathcal{X}}$  is corrupted from  $\mathcal{X}$  with a smaller bidirectional encoder,  $p(y_i | \bar{\mathcal{X}})$  is modeled with a larger bidirectional encoder and  $y_i = 1$  indicates  $\bar{x}_i = x_i$ .

### 6.2.2 Decoder-based Language Model

The decoder-based language model usually models the input text in an auto-regressive form, i.e., decoding each token according to all its previous tokens. Probabilistic language modeling (LM) is the most common unsupervised learning objective for the decoder-based language model. As shown in Fig. 16(b), its learning objective is defined as:

$$\mathcal{L}_{LM} = \sum_{i=1}^T \log p(x_i | x_1, x_2, \dots, x_{i-1}), \quad (12)$$

where  $p(x_i | x_1, x_2, \dots, x_{i-1})$  is the conditional probability of  $x_i$  modeled with an auto-regressive decoder. A major drawback of LM is that the token representation in the decoder can only encode the historical information of the previous tokens. To further consider the contextual information from both directions, bidirectional LM was proposed to model the input text with two LMs: a forward left-to-right LM and a backward right-to-left LM.

### 6.2.3 Encoder-Decoder-based Language Model

Compared to encoder-based and decoder-based language models, the encoder-decoder-based language model is more flexible due to the strong modeling ability of the encoder-decoder architecture. Denoising language modeling (DLM) is the most typical learning objective, aiming to recover the original undistorted input according to a partially corrupted input. As shown in Fig. 16(c), its learning objective is defined as:

$$\mathcal{L}_{DLM} = \sum_{i=1}^T \log p(x_i | \bar{\mathcal{X}}, x_1, x_2, \dots, x_{i-1}), \quad (13)$$

where  $p(x_i | \bar{\mathcal{X}}, x_1, x_2, \dots, x_{i-1})$  is modeled with an encoder-decoder model,  $\bar{\mathcal{X}}$  is randomly perturbed text from  $\mathcal{X}$ , which can be done with several ways [289, 19]:

- **Token Masking:** Randomly masking parts of the tokens from the input text. This way can be viewed as modeling the MLM objective in the encoder-decoder-based language model.
- **Text Infilling:** A harder form of token masking, which randomly replaces a number of text spans with a single [MASK] token. Hence, the model requires to predict how many tokens are actually masked for a masked span.
- **Token Deletion:** Randomly deleting tokens from the input text. Different from token masking, token deletion requires the model to decide which tokens have been deleted. When the deleted tokens are all at the end of the input text, it can be viewed as modeling the LM objective in a harder way.
- **Token Permutation:** Shuffling all tokens in random order.
- **Sentence Permutation:** Dividing a document into sentences based on full stops, and randomly sampling a sentence permutation from all possible permutations.
- **Document Rotation:** Rotating the document based on a randomly selected token so that it begins with that token. This way requires the model to identify the real start position of the document.

### 6.3 Pre-Training-then-Fine-Tuning

In the era of deep learning, the conventional training-testing paradigm learns models for specific tasks from scratch. Although training task-specific models is an effective approach for NLP, the specially designed models can not generalize to other tasks, and they also require sufficient labeled data for training. Further, the overfitting issue hinders the construction of big models. To cope with this issue, pre-training-then-fine-tuning paradigm has been proposed and reshapes the NLP area. Table 9 reports representative big models in NLP and Fig. 17 illustrates practical tools for the implementation of big models..

Pre-training in NLP aims to capture intrinsic semantics inside texts without human annotations. To this end, self-supervised learning tasks, such as language modeling or word co-occurrence, have been widely adopted for finding linguistic knowledge from large-scale unlabeled corpora. In the fine-tuning stage, the big models can easily adapt to specific downstream tasks. Early pre-training works focus on distributed word representation learning like Word2Vec [52] and GloVe [61]. Based on word-co-occurrence, the pre-trained word vectors are capable of modeling word similarities and benefit many NLP tasks consistently. Despite their success, pre-trained word vectors are static, which makes it hard to represent polysemous words (e.g., play) and contextual semantics. For this problem, ELMo [290] pre-trains a 2-layer Bi-LSTM to produce contextualized word embeddings. However, the representation power is still limited by the shallow structure.

Besides word embeddings, there exists another road exploring BLMs. Early big models train auto-encoders or RNNs to capture general language properties. With the fast development of deep neural network architectures and computational resources, training large-scale language models with powerful Transformer backbone becomes possible. After pre-training, big models output high-quality text representations that generalize well for downstream tasks. Therefore, fine-tuning big models demands training a few parameters from scratch. Transformer-based big models like BERT [18] and GPT [26] have revolutionized NLP. With millions, even billions of parameters, big models achieve state-of-the-art on a wide range of NLP benchmarks, including both language understanding and generation. Due to the strong representation and generalization ability, big models have become standard backbones in most NLP tasks.

Among different big models, the pre-training tasks are crucial for language modeling. Typically, there are three mainstream pre-training tasks: autoencoding modeling, autoregressive language modeling, and seq2seq modeling. Next, we will discuss different kinds of big models with respect to their pre-training tasks.

#### 6.3.1 Autoencoding Modeling

The unidirectional language models only capture attention weights from one side, which is suboptimal for language understanding. To fully exploit the context texts, autoencoding modeling corrupts part of the texts and asks the model to recover the corrupted texts. With contextualized representations from both sides, big models based on autoencoding modeling have been prevailing in natural language understanding, among which BERT is a milestone model.

BERT utilizes the bi-directional Transformer encoder to produce word representations. To realize autoencoding modeling, BERT proposes the masked language modeling (MLM) objective. Basically, MLM randomly masks a token in a sentence and tries to predict the masked token. For example, with the sentence “China is located in Asia.”, we mask the word “Asia” using the [MASK] token and ask the model to predict the word from the context. In the whole corpora, BERT selects 15% words to predict.

However, one major problem of MLM is that the special [MASK] token will not appear in the fine-tuning stage. To prevent the model from focusing on the [MASK] token, BERT only replaces the original words with [MASK] for 80% of the time. The target words are replaced by a random word in 10% of the time and remain unchanged in 10% of the time. To overcome the out-of-vocabulary problem, BERT represents token inputs by summing three embeddings: 1) Token embedding. BERT splits words into subwords by WordPiece and uses token embeddings to represent each

subword. 2) Segment embedding. When there are more than one sentences, such as NLI and QA, BERT uses segment embeddings to distinguish them. 3) Position embedding. Same as conventional Transformers, BERT adds position embeddings to encode token position information. BERT pushes natural language understanding a step forward and achieves remarkable performance on benchmarks like GLUE [291].

On the basis of BERT, a series of improvement works are proposed. RoBERTa [292] is the most influential BERT variant. By adopting multiple training tricks and more data, RoBERTa shows that BERT is significantly undertrained. With the same architecture as BERT, RoBERTa reaches superior results on almost all benchmarks. For efficient pre-training and inference, DistilBERT [293], ALBERT [294], and TinyBERT [295] are representative BERT variants in parameter reduction and acceleration. With little performance loss, these models lead to considerable resource consumption cuts. To incorporate external knowledge into BERT, some works like ERNIE [162] and KnowBERT [180] utilize entity and relation embeddings from knowledge bases to get informative entity and relation representations. KEPLER [163] further models knowledge and language jointly through Wikidata descriptions, producing enhanced knowledge embeddings and text representations.

### 6.3.2 Autoregressive Modeling

Auto-regressive (AR) modeling adopts sequential probability modeling, which assumes that the probability distribution of a word at a certain position is decided by the former words as shown in equation 12. This is consistent with the nature of language modeling. It is worth noting that AR models are different from recurrent models. The previous content only provides another input to the model instead of the hidden state, therefore an AR model is merely a feed-forward model. Compared with AE pre-training, the original form of natural language in AR pre-training is not affected by the mask token, and therefore the gap between pre-training and fine-tuning becomes smaller. Besides, the influence of masked words' conditionally independence can also be ignored. However, the one-way encoding of AR models does not make full use of the context and may lose the comprehension of two-way encoding to some extent.

One representative AR model is GPT [26], the earliest big model. Different from BERT [18], GPT utilizes the Transformer decoder instead of the encoder to realize next word prediction. The window size is set as  $k$ , and the model is required to predict the word when given the  $k$  words before the current position. Token inputs for GPT are composed by token embedding and position embedding, just as mentioned in Sec. 6.3.1. Segment embedding is not needed, since GPT processes the text multiple times for tasks with more than one input segment, including multiple-choice and sentence similarity. GPT performs excellently on both large-scale and small-scale downstream datasets. Especially, due to the generative capability learned from pre-training, GPT even shows promising performances in some zero-shot tests.

Later, GPT-2 [48] and GPT-3 [20] are proposed, showing the great potential of a larger parameter scale and pre-training corpus. In terms of text generation, GPTs achieve good results, while loss of control of generated content is likely to bring potential risks. Further AR models such as CTRL [65] solve this problem by estimating the domain of unsupervised pre-training corpus and controlling the style of output. To break the limitation of fixed-length content and catch the longer-term dependency in text, transformer-xl [296] adopts segment-level recurrence and relative positional encoding to solve the context segmentation problem. However, the efficiency becomes lower when the models become larger, and the input text becomes longer. Reformer [297] reduces the complexity by introducing the LSH attention module and RevNet framework.

A special instance is XLNet [298], which tries to combine the advantages of AE modeling and AR modeling. The permutation language model in XLNet pre-training helps the model see not only context before but also after the current position, and does not introduce noise caused by the masked token. The permutation training is achieved by two-stream attention, which splits the attention masks for the content and the query in Transformer. These improvements have brought a significant improvement in the performance of the model.

### 6.3.3 Sequence-to-sequence Modeling

Sequence-to-sequence (seq2seq) modeling is a comprehensive method that helps improve the understanding and generative capability of big models. Unlike AE models (using Transformer encoder) and AR models (using Transformer decoder), seq2seq models are usually in the encoder-decoder framework. As explained in formula 13, given the input sequence and the generation results before the current position, models are required to predict the next output word.

Seq2seq modeling is initially proposed for text conversion tasks such as translation and summarization. Unlike AR models, seq2seq models usually generate output text that is of a different nature from the input sequence (e.g., answers and questions, target language and source language, summaries and original texts and so on), thus it is more reasonable to process the input understanding and the output generation separately. Unfortunately, seq2seq modeling faces some challenges, including exposure bias during training. Teacher forcing training may cause a gap between training and testing. On the contrary, providing predicted input for decoder may lead to slow training speed and





**Fig. 17.** Representative practical tools for big models. Platform: Pytorch [234], Tensorflow [232], PaddlePaddle [233], and MindSpore [308]; Implementation of big models: Huggingface Transformers [309], Megatron-LM [201], and FasterTransformer [310]; Technology: DeepSpeed (ZeRO optimizer) [311], FairScale (Fully Sharded Data Parallel) [312]; Application: OpenPrompt [313], BMInf [314], GPT3-Demo, ERNIE-Demo

difficulty in convergence. Some training techniques (scheduled sampling, beam search, etc.) are explored for seq2seq modeling.

Traditional seq2seq models rely on RNNs, which have difficulty in parallel computation. Transformer has an exquisite attention mechanism, and the encoder can realize parallel computation. It becomes the backbone of not only the subsequent seq2seq BLMs but also popular AE and AR models. BART [289], the classical seq2seq big model, adopts Transformer to unify BERT and GPT. Similar to GPT, BART takes token embedding and position embedding for the input. During pre-training, BART is required to restore the corrupted input sequences. Compared with BERT, the corruption method of BART is far more flexible. Multi-token masking, token deletion and token filling can change the sequence length and improve the generative capability of BART. Sentence permutation and document rotation further propose a high requirement for long context comprehension. BART achieves comparable performance on understanding tasks with RoBERTa [292] and gets SOTA performance on generation tasks. Pegasus [299] has a similar structure with BART while adding two objective functions about MLM and gap sentence generation. T5 [19] is another representative seq2seq big model, and the position embedding is replaced with relative position embedding. It unifies various tasks in the form of generation. Apart from the BERT-style mask prediction task, T5 pre-training also adopts some supervised tasks using prefixes to distinguish them. ProphetNet [300] further extends the two-stream attention introduced in Sec. 6.3.2 to the n-stream attention and realizes n-gram prediction instead of next token prediction.

#### 6.3.4 Fine-tuning

In order to adapt to various downstream scenarios, the BLMs are fine-tuned on different tasks with a relatively small learning rate and few steps. Pre-training-and-then-fine-tuning is also the most common paradigm for using big models. For generative tasks (translation, summarization, story generation, style transfer, etc.), AR models read and repeat the input text (if there exists) before outputting the predicting context, while seq2seq models are tuned to directly read the input sequence and generate the corresponding output sequence. For understanding tasks, there may exist multiple input segments such as the text pair in natural language inference and the question and choices in the multiple-choice task. They are either separately provided to the models and encoded several times (such as GPT) or concatenated together as a whole input (such as BERT). Most understanding tasks are in the form of classification. The BLMs read and provide embeddings to the classifiers. The classification layer can be initialized by the pre-trained checkpoint when the label list is the vocabulary list such as cloze task, while has to be re-defined most of the time such as sequence labeling task and sentiment classification task.

Vanilla fine-tuning adds task-specific classifiers and objectives to adapt big models to downstream tasks. However recently, an alternative approach, prompt-oriented fine-tuning, is receiving considerable attention [48, 20, 315, 145, 316]. By injecting additional textual or special tokens to the original input, we could formalize downstream tasks as the language modeling tasks in the pre-training stage. For example, considering a binary sentiment classification for the sentence “Albert Einstein is one of the greatest intellects in his time.” Assume the addition tokens are “<text> It is <mask>”, where the token <text> stands for the original text, and we further map the positive class to the word “great”

**Table 9.** Different Big Language Models. #params (0.1, 0.3) represents the number of parameters commonly used for different sizes of the model in billions. (Keys: En = Encoder-based Language Model, De = Decoder-based Language Model, En-De=Encoder-Decoder-based Language Model, MLM = Masked Language Modeling, LTR = Left-To-Right Language Modeling, RTL = Right-To-Left Language Modeling, Seq2Seq = Sequence-To-Sequence Language Modeling, mono = Monolingual, multi = MultiLingual, KB = Knowledge Base)

Model Name	LM (#params)	Objective (+Auxiliary)	Data	Noise
BERT [18]	En (0.1, 0.3)	MLM(token) +Next Sentence Prediction	mono	-
RoBERTa [292]	En (0.1, 0.3)	MLM(token)	mono	-
SpanBERT [301]	En (0.1, 0.3)	MLM(span)	mono	-
DeBERTa [302]	En (0.1, 0.4, 0.7, 0.9, 1.5)	MLM(token) + Disentangled Attention and Enhanced Decoder	mono	-
UniLM [303]	En (0.3)	MLM(token) + LTR + RTL + Seq2Seq + Next Sentence Prediction	mono	-
ELECTRA [288]	En (0.1, 0.3)	MLM(token) + Replace Token Detection	mono	-
XLM [304]	En (0.6)	MLM(token) + Translation Language Modeling	multi	-
KnowBERT [180]	En (0.1)	MLM(token) + Knowledge Attention and Recontextualization	mono + KB	-
K-BERT [181]	En (0.1)	MLM(token) + Knowledge Soft-Position and Visible Matrix	mono + KB	-
ERNIE (Tsinghua) [162]	En (0.1)	MLM(token) + Knowledge Alignment + Entity Auto-encoder	mono + KB	-
ERNIE (Baidu) [186]	En (0.1)	MLM(token, entity, phrase)	mono + KB	-
ELMo [290]	De	LTR + RTL	mono	-
GPT [26]	De (0.1)	LTR	mono	-
GPT-2 [48]	De (1.5)	LTR	mono	-
GPT-3 [20]	De (175)	LTR	mono	-
CPM-1 [222]	De (2.6)	LTR	mono	-
XLNET [298]	De (0.1, 0.3)	LTR	mono	Token Permutation
BART [289]	En-De (0.1, 0.4)	MLM(span)	mono	Token Deletion + Sequence Permutation + Document Rotation
T5 [19]	En-De (0.1, 0.2, 0.7, 3, 11)	MLM(span)	mono	-
PEGASUS [299]	En-De (0.6)	MLM(token, sentence)	mono	-
CPM-2 [305]	En-De (11)	MLM(span)	mono / multi	-
Switch-Transformer [268]	En-De ( 385, 1600)	MLM(span)	mono / multi	-
mT5 [306]	En-De (0.3, 0.6, 1.2, 3.7, 13)	MLM(span)	multi	-
ByT5 [307]	En-De (0.3, 0.6, 1.2, 3.7, 13)	MLM(byte-span)	multi → byte	-

and the negative class to the word “terrible”. The final input becomes “Albert Einstein is one of the greatest intellects in his time. It is <mask>”, and we feed it into the big model to conduct masked language modeling. If the probability of “great” is higher than “terrible”, then this sentence is classified to the positive class. We denote the additional tokens as template and the mapping from labels to words as verbalizer. Intuitively, prompt-oriented fine-tuning bridges the gap between pre-training and model tuning. Empirically, such a strategy is proven to be surprisingly effective in numerous NLP tasks, especially when supervision is insufficient [317]. Efforts have been made to explore better ways to generate templates [318, 319, 320] and verbalizers [321], as well as advanced applications [315, 146, 322, 323]. OpenPrompt [313] provides a unified programming framework to flexibly conduct prompt-oriented fine-tuning.

### 6.3.5 Parameter-efficient Tuning

As the size of big models increases, tuning all the model parameters may lead to a serious issue. That is, numerous copy of separate fine-tuned models for different tasks are generated. This will make the training procedure exceedingly expensive, and the fine-tuned models may occupy tremendous storage space, which is especially impractical with the increasing size of big models. To alleviate this issue, a new paradigm to adapt the big models, namely parameter-efficient tuning, is recently developed, whose central idea is that most parameters of the big models are fixed and only a few parameters are updated during model tuning. Current parameter-efficient tuning approaches mainly fall into three groups, which are *adapter-based tuning*, *prompt-based tuning* and *additive tuning*.

The first strategy adds newly introduced lightweight neural modules to all the layers of the Transformer, and only parameters of such modules are optimized during training while keeping the original pre-trained parameters frozen [324]. In this way, we could separately train adapters for different tasks and share one same big model, and only storing adapters will significantly reduce the cost of adaptation for big models. Architectures of adapters may vary according to the specific tasks and languages, including two adapter layers per Transformer block or one adapter layer with an additional LayerNorm per Transformer block. Empirically, adapter-based tuning demonstrates competitive performance with full fine-tuning on various NLP tasks. Variants of the adapter-based method extend this strategy to more scenarios such as multi-lingual, multi-task and few-shot learning [325]. AdapterHub [326] is a library to provide PyTorch APIs to reuse and share adapters.

The second strategy of parameter-efficient focuses on the input layer, whose core idea is to add tunable tokens, i.e., prompts, to the input or hidden layers. Representative methods of this strategy is prefix-tuning [144] and prompt-tuning [327]. Note that compared to prompt-oriented fine-tuning introduced in Section 6.3.4, although prompt-based tuning also injects prompts to the input, this strategy places more emphasis on the purpose of optimizing only the parameters of the prompt and so as to achieve parameter-efficient adaptation. Prompt-tuning shows an increasing performance as the size of the models increases, and when the number of model parameters reaches the tens of billions, this approach can achieve performance comparable to that of full parameter fine-tuning. Prefix-tuning demonstrates the robustness of this method in out-of-distribution evaluation. Studies also imply that we could inject such prompts into the pre-training stage [328] to better use such prompts to stimulate big models and thereby handle the low-data regime. Using prompt-based tuning is also verified as an effective approach to explore the mechanisms behind big models. Researchers find that we could find a common intrinsic space for various distinct NLP tasks, and satisfying performance could be yielded by only optimizing very few parameters in this space [329].

The third group of methods is additive tuning, which treats the parameters of the big model after fine-tuning as an addition (or difference) to the pre-trained parameters. LoRA [330] fixes the pre-trained parameters and injects trainable rank decomposition matrices into each layer of the Transformer to reduce the number of trainable parameters. Diff pruning [331] learns a sparse task-specific vector that is adaptively pruned during training. The side-training approach [332] trains a lightweight side neural network that is fused with the frozen big model. Although each of these three approaches has its own focus, the central idea is to keep the pre-trained parameters constant while training lightweight alternatives to achieve adaptation for downstream tasks. There have also been some recent attempts to grasp the internal connection of these strategies and build a unified parameter-efficient tuning framework [333, 334].

## 6.4 Typical Tasks

### 6.4.1 Text Classification and Matching

Text classification and matching are fundamental and typical NLP tasks. These tasks usually require neural models to understand the semantic information behind the textual representations and have lots of real-world applications, such as sentiment analysis [335, 286], textural entailment [336, 337] and information retrieval [338, 339, 340, 341].

**Text Classification.** Generally, existing work [342, 18, 292, 343] usually encodes texts  $x$  with attribute neural architectures  $f()$  and gets the representations of given texts. Then the text representations are used, aiming to classify

texts into different categories  $y_i$ ,

$$p(y_i|x) == \frac{\exp(f(x)^\top \mathbf{y}_i)}{\sum_{j=1}^M \exp(f(x)^\top \mathbf{y}_j)}, \quad (14)$$

where  $\mathbf{y}_j$  is the representation of the category  $y_j$ . Then the neural network is trained with the cross entropy loss,

$$\mathcal{L}_{\text{CrossEntropy}}(f) = \sum_{i=1}^N \sum_{j=1}^M y_j(x_i) \log p(y_j|x_i), \quad (15)$$

where  $N$  and  $M$  represent the numbers of training examples and label categories respectively.

Sentence representation is one of the most core technologies in the text classification task, thus existing work usually aims to enhance the ability of text encoder  $f()$ . Recently, benefit from the development of BLMs and its variants, such as BERT [18], fine-tuning BLMs shows great success in downstream tasks. Specifically, existing sentence representation models always employ the [CLS] embedding to represent text or text pairs. Nevertheless, the sentence embeddings encoded by BLMs are collapsed and mapped into a small area [344, 345, 346, 347], making the performance of sentence representations significantly inferior in terms of semantic textual similarity [339] and even worse than GloVe embeddings [61] without fine-tuning [347]. Some work also demonstrates that the averaged context embedding consistently outperforms the [CLS] representation. All these mixed experimental results illustrate that existing sentence representation pre-training methods, such as Next Sentence Prediction (NSP) [18] and Sentence Order Prediction (SOP) [294], can not sufficiently train sentence representations. To alleviate the shortcoming of existing sentence representation pre-training methods, SEED encoder [348] employs the auto-encoder mechanism to train sentence representations. It aims to enhance the encoder module to capture more information with its [CLS] representation by recovering the input sentences with a shallow decoder. On the other hand, inspired by the self-training methods in computer vision [190], sentence representation pre-training methods also leverage several methods to construct the sentence pairs with the same semantic information [349, 350] and contrastively optimize the sentence representations. Specifically, the sentence pairs can be generated through back-translation [349], some easy deformation operations [350], and original sequence cropping [351]. ConSERT [345] further comes up with multiple data augmentation strategies for contrastive learning, including adversarial attack, token shuffling, cutoff, and dropout. Besides, SimCSE [352] learns sentence representations with unsupervised data by predicting a sentence itself with dropout noise. Even though there are lots of successful attempts on sentence representation learning, it is still challengeable to construct contrastive sentence pairs effectively like images augmentation [353, 354], compress sentence semantic information into the [CLS] representations [355] and activate the ability of BLMs with some well-designed prompts [356].

**Text Matching.** Different from text classification, text matching models usually focus more on extracting semantic matching signals from text pairs  $\{x, \tilde{x}\}$  and estimate their relevance. The text matching models can be categorized into interaction-based ones [338] and representation based ones [357, 358]. The interaction-based matching models usually feed the concatenated sentence pairs to neural networks and calculate their relevance score  $s(x, \tilde{x})$ ,

$$s(x, \tilde{x}) = \mathbf{w}^\top f(x, \tilde{x}) + \mathbf{b}, \quad (16)$$

where  $f()$  denotes the text encoder.  $\mathbf{w}$  and  $\mathbf{b}$  are learnable parameters. On the other hand, representation based models encode sentences individually and calculate the relevance score with vector similarity evaluation methods, such as dot product,

$$s(x, \tilde{x}) = f(x)^\top \cdot f(\tilde{x}). \quad (17)$$

Information Retrieval is one of the most typical applications of the text matching task. In real-world information retrieval systems, both representation-based and interaction-based text matching models are used and show their advantages in different scenarios, such as retrieval and reranking stages. To train neural models, the relevance scores are usually optimized with the contrastive training loss,

$$\mathcal{L}_{\text{ContrastiveLoss}}(f) == \frac{\exp(s(x, \tilde{x}_i))}{\sum_{\tilde{x}_j \in \tilde{X}^-} \exp(s(x, \tilde{x}_j))}, \quad (18)$$

where  $\tilde{x}_i$  is the relevant sentence with  $x$  and  $\tilde{X}^-$  denotes the irrelevant sentence set to  $x$ .

The negative examples are crucial in such contrastive training paradigm and guarantee neural models to achieve convinced text matching performance [359, 358, 360, 361]. Early work [358] usually constructs the negative collections from random sampling, unsupervised retriever, and in-batch documents training. Nevertheless, such easily distinguished negatives may be uninformative and lead to diminishing gradient norms along the model training process [360, 362]. To deal with such a problem, some research selects the most confusable negatives according to optimized text matching models [360] and comes up with self-involvement methods to optimize model parameters during training [361]. Compared with interaction-based text matching models, the representation-based ones project queries and documents

in an embedding space and always conduct a more serious unstable training process. Lots of representation-based text matching models still need warm-up training with BM25 retrieved negatives and fix the document representations when fine-tuned on the downstream tasks [360]. Existing work [363,364] has proved that such a contrastive training objective optimizes neural models to keep two properties of the whole embedding space, “alignment” and “uniformity”. Specifically, the “alignment” property assigns similar embedding features to query and its related documents and conducts better clustering for similar document representations; “uniformity” encourages encoders to maintain maximal information for documents. In this case, optimizing text embeddings to keep a more smooth embedding space and avoid the embedding space collapse still need more studies to guarantee the matching performance of representation-based text matching models [364,360].

The effectiveness of recent neural-based text matching methods heavily relies on large-scale relevance supervision signals to learn matching patterns with end-to-end training, e.g., relevance labels or user clicks [341]. Nevertheless, in real-world ranking scenarios, sufficient relevance labels require search logs from commercial search engines or expensive human labeling in academic settings or vertical domains. The BLMs, such as BERT [18] do not effectively alleviate the data dependence problem and might require more training data than shallow neural ranking models [365,366,338]. A promising direction to alleviate the data dependence problem of neural text matching models is to leverage weak supervision signals that are noisy but available for the public [367,368,369]. There are various weak supervision sources that can be used to approximate the query-document relevance signals and train neural text matching models. To train neural ranking models, the text matching scores calculated by unsupervised retrieval methods, such as BM25, can be used as relevance labels to weakly supervise text matching models [368]. Besides, the title-body relation in web documents [370] and anchor text with their linked pages [371] can also be treated as weak supervisions to approximate the relations between matched query-document pairs. Despite such weak supervision sources have presented convincing results in the text matching tasks of the web domain, directly applying them to train text matching models for other domains will suffer from domain adaption problems and may get suboptimal outcomes. Query generation [372] provides a promising way to synthesize query-document relevance labels and solve the domain adaption problem by using a seq2seq model to generate pseudo queries. Specifically, the query generation models are trained with large-scale relevance signals from the source domain and applied to the target domain documents. CTSyncSup [373] further encourages query generation models to capture more important and specific information from the given documents by considering confusable document pairs and generating queries contrastively. To further guarantee the model performance trained with weak supervision, learning to judge data quality has received much attention. These methods usually design some neural networks to distinguish the ‘real’ data from the mixed data collections [374,375,376]. But these methods usually capture some undesired patterns to tell apart the ‘real’ and ‘pseudo’ data. ReinfoSelect [371] and MetaAdaptRank [373] provide good attempts by selecting or reweighting weak supervision data according to the needs of the text matching models during the different periods of the training process.

#### 6.4.2 Sequence Labeling

Sequence labeling is a classic task in natural language processing. Given a sequence of elements  $x_{1:T}$  as the input, which is usually a piece of text with  $x_i$  being words, we need to classify each  $x_i$  into a label  $y_i$ . A broad range of tasks can be formalized into the sequence labeling problem. Part-of-speech tagging requires identifying the part-of-speech of each word in the sentence, which can be directly mapped into the sequence labeling problem. Other tasks that require identifying spans of text which have certain properties in a sentence can be converted to sequence labeling by predicting each token into a label denoting the relative position of the span. For example, in Named Entity Recognition (NER), we predict words into B(begin of an entity), I(inside an entity), O(outside an entity), E(end of an entity), S(single word entity). Another example is Chinese word segmentation, where the label set is defined as  $\{B, M, E, S\}$ , representing the beginning of a word, in a middle of a word, end of a word, and single-character words, respectively.

Traditionally, sequence labeling is tackled by an encoder-decoder architecture (Fig. 18(a)), where the encoder is used to gather information to produce the contextualized representation of each token in the sequence, and the decoder is used to map from the contextualized representation into the label space [377]. In this encoder-decoder approach, the BLM is used mainly in the encoding stage. The decoder typically uses statistic models such as Conditional Random Fields [378,379]. This approach, though intuitive, does not fully leverage the potential of BLMs as the contextualized representation for each token is not optimized for sequence labeling tasks. Moreover, the decoder is learned from scratch and doesn’t utilize the rich knowledge learned in the pre-training stage.

The differences between the pre-training objectives of the big model and the objectives of sequence labeling tasks have motivated researchers to bridge the gap by introducing unified objectives to tackle the problem. As a result, a noticeable amount of paradigm shifted [380] has been observed in sequence labeling tasks. Grounded on NER tasks, [148] proposes to use natural language questions to generate the named entities in a sentence (Fig. 18(c)), for each type of named entity, the questions are handcrafted and then trained on the training data. However, for each input sentence, this formulation has to enumerate all the types in the typeset, which makes it inefficient. Different from converting

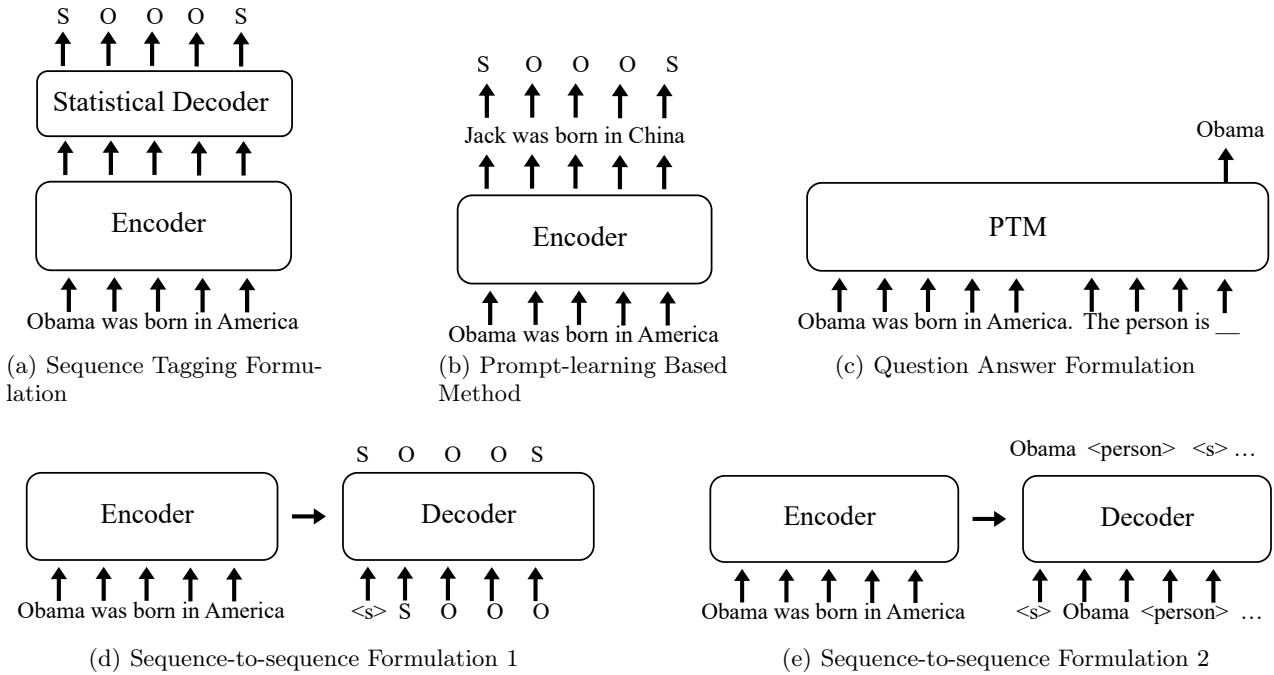

**Fig. 18.** Sequence labeling tasks, especially NER, have been tackled using different paradigms.

the sequence labeling into question answering, [381] proposes to use sequence-to-sequence architecture to generate the tagging sequence of the input sentence (Fig. 18(d)). However, the tokens composing the tagging sequences (e.g., O, B, I, etc.) didn’t appear in the pre-training stage, leaving a large learning gap for the models. The subsequent work [382] proposes to generate a sequence composing of the named entity and the tagging instead of the tagging token sequence (Fig. 18(e)). For example, compared to generating “S O O O S” for sentence “Obama was born in America”, this work instead generates sentence resembling natural language like “<s> Obama <person> <s> America <location>”. Thus, the named entity recognition tasks, as a form of sequence labeling task, actually have been tackled using the conditional generation approach. This approach not only can generate all types of entities in one pass but also has the potential to handle nested entities which is common in real NER applications. Thus this approach enjoys a robust performance gain from the previous methods.

However, there are still many under-explored problems in adapting sequence labeling problems to the big model paradigm. (1) Most works only explore NER tasks, leaving other various forms of sequence labeling tasks untouched. Although many conversions that narrow the gap between BLMs and the sequence labeling tasks are successful in NER tasks, how versatile are these conversions is not well studied. (2) Although suffering from inferior performances, traditional methods only require one pass of the input sequence to generate the tags in all positions. After the paradigm shift, most of the works require more than one forward pass to generate the tagging sequence. For example, in the sequence-to-sequence conversion, we need to generate the output tokens one by one. Moreover, if the generation uses beam-search-related methods, we may expect it to take more memory usage. The conversion to question answering suffers more since it has to enumerate all types of tags. In the big model paradigm, training and inference overhead is not ignorable, which calls for more detailed researches and innovations in this direction. Recently, a prompt-learning [315] based methods [383] propose to select the word from the vocabulary as the tag of the input elements (Fig. 18(b)). However, whether this conversion is applicable in other sequence labeling tasks remains unknown.

### 6.4.3 Machine Translation

Machine translation is a technology that leverages computers to translate human languages automatically. Neural machine translation employs deep neural networks and directly maps source and target languages with end-to-end training. These machine translation methods are data-driven and heavily depend on large-scale and high-quality parallel resources, which even showcase some potentials to achieve human-level translation ability. In recent years, BLMs have proved their effectiveness in utilizing massive unlabeled monolingual texts and achieving state-of-art performance in many NLP tasks. In machine translation, researchers pay more attention to exploring how to take full advantage of unlabeled data with effective pretraining methods for neural machine translation models. Thus various kinds of BLMs, such as BERT, GPT, MASS, XLM, BART, T5, and mRASP, are explored elaborately to transfer

linguistic knowledge to machine translation from different NLP tasks and various languages. We refer readers to Section 14 for a more detailed discussion on the machine translation task.

#### 6.4.4 Reading Comprehension and Question Answering

The Question Answering (QA) [384] task has been a long-standing problem in NLP, Information Retrieval (IR), and related field tasks [385]. The QA systems have the ability to deal with statements or questions expressed in natural languages and give appropriate answers according to questions, allowing humans to establish interactions with computers in a way that is natural to us. They help users find information efficiently. For example, suppose a user asks “when was Barack Obama born?”. In this case, an ideal QA system is expected to return “August 4, 1961”.

The QA task can be earlier derived from the IR community and make users carry out particular information from web searches conveniently. In most IR systems, a series of related documents will be returned by search engines as results, but these documents usually contain both useful and useless information, increasing users’ burden of reading and filtering documents to seek really useful information. As a result, the QA models are proposed to automatically find answers from several documents, which is regarded as the next version of search engines. Generally, QA tasks can be categorized into three groups: (1) Machine Reading Comprehension (MRC) task gives the QA system several documents and then requires it to answer the given question according to these documents; (2) By contrast, the open-domain QA task is a more difficult, as the QA system is required to search relevant documents and find answers from the retrieved documents; (3) the last category is the Knowledge-Based QA (KBQA) task, where the QA system will answer questions based on structural knowledge graphs, like Freebase or Wikidata. In the rest, we mainly discuss machine reading comprehension and open domain question answering.

**Machine Reading Comprehension.** The earlier reading comprehension models mainly focus on the cloze test and the multiple-choice reading comprehension task. In the cloze test, for example, given a query “Producer [MASK] will not press charges against Jeremy Clarkson, his lawyer says”, QA models are asked to choose the answer word from several candidates, which can fill this masked token in the given query. The multiple-choice reading comprehension task requires reading comprehension models to choose answers from several provided candidates [386]. The above two kinds of reading comprehension tasks are provided a set of candidate choices and are expected to tell apart the golden answer from several possible candidates, aiming at evaluating the models’ ability in understanding and reasoning. Different with them, the extractive reading comprehension task [387,388] aims to extract the answer spans from the corresponding reading passages, which asks the extractive reading comprehension model to judge the question might be unanswerable or to answer questions in the form of text. The extractive reading comprehension task is a more general setting in the QA area, and we mainly discuss it in the rest of this part.

To extract answer spans from one given paragraph, the extractive reading comprehension task usually establishes a reader by employing neural models as sentence encoders and training neural models to directly predict the start and end positions of the answer spans [389]. Recently, thanks to the development of BLMs, reading comprehension models conduct better understandings on input sentences and achieve great improvements on the extractive reading comprehension datasets [18,298,294]. Even though these BLMs have achieved amazing performance, some research proves that those reading comprehension models might overly rely on the relevance between question and documents, instead of really understanding questions and documents [390]. For example, researchers try to convert the questions to declarative sentences, replace some key information with wrong information, and then append such sentences with misinformation to the end of the given document. Surprisingly, most of the models conduct poor performances on such a modified reading comprehension dataset. The reason mainly lies that current reading comprehension models lack the deep reasoning ability and semantic understanding ability. Some possible ways further consider the characteristics of reading comprehension tasks and improve the reasoning ability of language models with the reading comprehension oriented pretraining methods: (1) involving reasoning about relationships between two or more spans of text [301] (2) applying commonsense knowledge and external knowledge into reading comprehension models [391,162,185], and (3) considering discourse relation and co-reference [392]. Besides, due to the emergency of BLMs at large scales, directly answering the given question may be possible. Researchers regard BLMs as knowledge storage and generate answers through a generation model without external knowledge [92,48,393].

We have discussed the reading comprehension task that answers the questions with only one paragraph. However, a more general and realistic setting is that QA models are provided with multiple paragraphs and find the answers from several paragraphs. Because of the long document processing problems in NLP [394], directly concatenating all paragraphs seems ineffective on the reading comprehension task with multiple paragraphs. To handle the multiple paragraph issue in the reading comprehension task, the NLP community has emerged several possible approaches: (1) pipeline systems, which select a single paragraph and run the reading comprehension model on that paragraph [395]; (2) confidence systems, which run the reading comprehension model on all paragraphs and assign a confidence score to each candidate span in each paragraph [18]. On the other hand, existing work also focuses more on identifying the paragraphs that have no answer and verifying the quality of extracted answers [396,395]. The unanswerable questions are also regarded as an important research direction in reading comprehension models or even QA benchmarks [395,397,

398,399]. To deal with the question answerability problem, some work further improves the reading comprehension models by adding independent no-answer losses, applying answer verification, and estimating the answerability of answer spans [396,400,401]. Recently, some work [402] also employs the fact verification models [403] to estimate the quality of generated answers, which provides an opportunity to bridge both QA task and fact verification task [404].

**Open-Domain QA.** In reading comprehension tasks, we assume that the related paragraphs are given to the reading comprehension models, which is impractical in real-world applications. To remedy this, the open-domain QA task [405] is proposed, which requires QA models to search relevant paragraphs from a paragraph collection and read the retrieved paragraphs to return answers.

Earlier open-domain QA systems are usually established with a pipeline, which consists of several components to sever the whole QA system, such as question processing, passage retrieval, passage reader and answer processing. The DrQA model [405] is designed to answer the user questions with the knowledge supported by Wikipedia. This model first employs a document retriever, such as TF-IDF, to search some related documents and then leverages a paragraph reader to find the answer with the extractive reading comprehension model. Some work [406] also comes up with denoising models that filter the unrelated documents by jointly training a paragraph selector and paragraph readers. Nevertheless, the feature-based retrieval models also face several problems: (1) the feature-based retrieval models have the vocabulary mismatch problem and can not understand the semantic matching patterns, making the retriever returns unrelated documents to the reader; (2) The non-neural architecture based retrievers can not be joint trained with paragraph readers and show less effectiveness to learn the importance of different paragraphs according to the needs of downstream paragraph readers.

To alleviate the weakness derived from feature-based retrievers, DPR [358] first replaces the feature-based retrievers with dense retrievers. The dense retrieval model encodes both queries and documents with BLM BERT and retrieves documents in an embedding space. The dense retrieval models significantly improve the recall of the retrieval result, thriving on the whole open-domain QA systems [358,407,360]. In terms of the paragraph reader, some of existing open-domain QA models also use the seq2seq architecture to encode retrieved paragraphs and generate answers with the decoder module instead of using the extractive reading comprehension models [408,409]. Thanks to the usage of neural architectures in dense retrievers, the open domain QA systems can be trained end-to-end to use full Wikipedia and answer any factoid question [410,411,412,408]. The RAG model [408] first trains part of dense retrievers by only fine-tuning query encoders during training the seq2seq based paragraph readers. Besides, the passage importance signals can also be calculated with the paragraph readers, such as using hard EM models to train dense retrievers to satisfy the extractive reading comprehension models [413] or distilling the attention scores provided by the seq2seq based paragraph reader [414]. Another direction of the existing open-domain QA task is that directly matching paragraphs and phrases with dense retrieval models, which also shows strong efficiency and achieves comparable performance with retrieval-reader systems [410,411].

#### 6.4.5 Text Generation

Text generation is an important task in NLP, which aims to convert the input, linguistic or non-linguistic, into text [415,416,417]. The inputs can be text sequences, structural data and multi-modality data, making the neural models can generate natural texts according to image, knowledge graphs, tables, multilingual languages and so on. There are lots of important applications employ the text generation technologies in the real world, such as machine translation [418,419,4], text summarization [420,421,422], dialogue response generation [423,424,425], image captioning [14,426,427], and so on. With the development of BLMs, qualified output texts can be generated with neural generators, which are more fluent, grammatically correct, semantically logical, and easy to understand. The text generation models showcase the ability for query generation and data augmentation, benefiting lots of NLP tasks, such as information retrieval, question answering, grammatical error correction and so on. We refer readers to Section 15 for a more detailed discussion on the text generation task and models.

#### 6.4.6 Conversation

Building intelligent open-domain dialog systems that can coherently and engagingly communicate with humans in natural languages has been a standard to estimate whether a machine has the equivalent intelligence with humans. Benefitting from the development of BLMs, open-domain dialog systems have achieved significant advancements in generating a more coherent, consistent, and on-topic conversational response. Modern dialog systems usually train neural models with large-scale data and are built on top of transformer architectures with billions of parameter, such as DialoGPT [428], Meena [429], Blender [430], Plato [431,432,433], and Eva [434]. Even though these models have shown powerful performance in both automatic evaluation and manual evaluation, they still face many challenges to mimic human-like conversational behaviors, such as generating responses grounded on a particular persona, incorporating external knowledge to make responses more knowledgeable, and making dialog system emotionally intelligent. We refer readers to Section 16 for a more detailed discussion on dialog models and potential challenges.



## 6.5 Advanced Topics

### 6.5.1 Model Analysis

Although BLMs have shown their superior performance on a series of NLP tasks as introduced in the last section, it is still unclear what are the exact mechanisms that contribute to their success. To address this problem, a wide range of literature focuses on analyzing the internal mechanisms of BLMs, which can be divided into four categories:

1. **Knowledge of BLMs.** The implicit knowledge captured (or stored) by BLMs mainly contains two types: (1) **Linguistic knowledge.** Early analysis works on word embeddings have revealed that they are able to capture linguistic regularities in language by learning with neural language models objectives, such as the syntactic and semantic relationship between words [52], compositionality properties [52], taxonomic properties [435] and parts of attributes of entities [436]. Compared to conventional word embedding models which have fewer layers and less parameters, BLMs can learn rich linguistic knowledge through pre-training on massive unlabeled corpus. Recently, a large number of studies have probed and induced the linguistic knowledge in BLMs, including (a) internal representation analysis [437, 438, 439, 80, 440, 441, 22, 442, 443, 444], which builds a small probe classifier on top of internal representations from different layers to analyze the internal representations of BLMs can classify auxiliary linguistic tasks, from shallow part-of-speech tagging to higher parsing, coreference resolution and so on; (b) attention weight analysis [445, 446, 447], which computes statistics about attention matrices to study how specific attention heads are expressing linguistic phenomena, and attention heads combinations predict linguistic tasks such as conference or dependency relations; and (c) prompt-based generation analysis [448, 449, 450], which utilizes language models to directly estimate the probabilities of different sequences or words with specific-design input text (e.g., prompts) to verify some linguistic phenomena. (2) **World knowledge.** BLMs also learn rich world knowledge by self-supervised pre-training, mainly including factual knowledge, commonsense knowledge and numerical knowledge [451, 452]. For factual knowledge, [92] first proposes to query BLMs with “fill-in-the-blank” cloze statements, and construct LAMA (Language Model Analysis) task (a.k.a, knowledge prompts) to analyze what factual knowledge are captured by BLMs. Moreover, [453, 320, 319, 393] further explore to design better prompt form to acquire factual knowledge from BLMs. For commonsense knowledge, [454] first evaluates BLMs’ knowledge in the aspect of psycholinguists. After that, [455, 456] utilize a series of probing tasks to extract commonsense from BLMs, and reveal that BLMs have learned various commonsense features in their representation semantic space. Although various kinds of world knowledge have been found in BLMs, there exist some important rethinking: current BLMs’ representations cannot model the implicit relations well [457] and the success of knowledge generation may come from learning stereotypical neural associations [458]. For numerical knowledge, [459] probes probe BLMs on synthetic list maximum, number decoding, and addition tasks, and finds that the embeddings of BLMs naturally present a surprising degree of numeracy.

2. **Robustness of BLMs.** Recent works have focused on discussing the severe robustness problem of BLMs, mainly containing two types: (1) **Adversarial Attacking**, which generates new samples by small perturbation on the original inputs to mislead the BLMs’s into making wrong predictions. Current works utilize the model prediction, prediction probabilities, and model gradients of the fine-tuned BLMs to search adversarial examples, from char-level attacking [460], word-level attacking [461, 462, 463, 464, 465], sentence-level attacking [466, 467] to multi-level attacking [468, 469], showing that the robustness of BLMs to adversarial attacking is still far from perfect; (2) **Backdoor Attacking**, which inserts instances with specifically designed patterns into training data so that the trained BLMs may perform well on normal samples but behave badly on those samples with these patterns. Existing backdoor attacking works of big models mainly focus on exploring more types of triggers [470], data-free backdoor attacking [471], effectiveness on clean sets [472], effectiveness after fine-tuning [473, 474] and stealth attacking [475]. To sum up, big models have gradually become the fundamental services in NLP, but their robustness still remains a serious security threat when people deploy big models for real-world applications.

3. **Structural Sparsity of big models.** Most existing big models adopt deep Transformer as the basic architecture, and inevitably meet the over-parameterization problem. Early analysis on machine translation [476], abstractive summarization [477], and language understanding [478] have shown that a well-trained Transformer usually has redundant parameters, and can remove part of parameters without loss of performance. Recently, a series of work also discuss the over-parameterization problem in big models, containing the redundant heads in the multi-head attention layers [445, 478], the sparse activation phenomenon in feed-forward network layer [479], and parameter redundancy problem of the whole Transformer [480, 481]. This provides a novel perspective for model acceleration, and [480, 479] have shown that pruning or only activating part of the model parameters can effectively accelerate the model but not hurt its performance.

4. **Theoretical Analysis of big models.** Although big models have achieved great success in a wide range of downstream NLP tasks, how self-supervised pre-training works is still remaining a problem. In the early days of deep learning, [23, 73] found that layer-wise unsupervised pre-training can provide a better parameter initialization to accelerate convergence in later supervised fine-tuning, as well as a better regularization. Towards the recent development of self-supervised pre-training objective, [482] first conduct a theoretical analysis of contrastive unsupervised representation learning, which introduces the concept of latent classes and the semantically similar pairs are from the

same latent class. They further prove that the loss of contrastive learning is the upper bound of the downstream task loss, and thus optimizing the contrastive-based pre-training loss will also decrease the loss of downstream tasks.

### 6.5.2 Long Document Modeling

The ability to capture semantic in long documents is essential for many NLP tasks, such as summarization [299, 483], text classification [484, 485], information extraction [486, 487], and question answering [488, 489]. Except for integrating local information, long document modeling requires the models to capture long-term global dependencies, discourse relations and topic coherence of documents. Long document modeling is also an urgent need in many domains, such as in the scientific domain [490], legal domain [491]. However, many big models are mainly designed for shorter sequences and are suboptimal for long documents. To this end, many efforts have been devoted to exploring long document modeling with BLMs, and we divide them into following four categories:

1. **Efficient Transformer-based Models.** Due to the quadratic computational and memory complexity of self-attention, conventional transformer-based models usually cannot process documents with thousands of tokens. Thus, how to improve the efficiency of transformers to process long sequences is an important challenge. Following hierarchical structures of documents, some works attempt to employ multiple layers of transformer to generate sequence representations from sentence-level, paragraph-level and document-level context [492, 493, 494, 495]. Another mainline of efficient architectures is to approximate the attention matrices with various mechanisms: (1) Pre-defined Sparse Attention. These works propose to replace full-connected attention with pre-defined local attention, which encodes local contextual information and global attention that builds global sequence representations. Local attention reduces the field of view to limited context for most tokens with blockwise attention [496, 497] or stride window attention [498, 499]. Besides, global attention allows some selected tokens, such as [CLS], query tokens in question answering task, to attend the whole sequence to preserve the long-term information. (2) Learnable Sparse Attention. Models with learnable attention patterns determine the field of view in attention according to token semantic similarity, and only the tokens in the same clusters can attend to each other. Reformer [297] employs locality-sensitive hashing to cluster tokens into several buckets, and Routing Transformer [500] uses k-means to achieve token clustering. (3) Low Rank Approximation. Based on the observation that self-attention matrices are low rank [501], researchers attempt to rewrite the self-attention equation to avoid explicitly computing the quadratic attention matrices [501, 502, 503]. Moreover, some researchers find that not all words are needed for document representations. Therefore, these works eliminate words layer by layer in big models to reduce the memory requirements [504, 505, 506]. Efficient transformer-based models mainly focus on reducing the computational and memory requirement of transformers, thus these models can be employed for long sequences.

2. **Memory-based Models.** Inspired by the working memory theory, the memory mechanism has been widely used in neural networks to capture important long-term information [280]. In big models for long documents, many researchers attempt to leverage a memory module to provide global features for the whole sequence. For instance, the global attention used in efficient transformer-based models can also be regarded as one type of memory module [498, 499]. Besides, recurrence-based models are also important memory-based models. These works divide documents into several segments and model the documents segment-by-segment. During the process for each segment, the memory which contains information from previous segments can provide long-term dependency. Transformer-XL [296] directly utilizes the hidden states from the last segments as the memory. Furthermore, Compressive Transformer [507] and Memformer [508] design memory compression mechanism to enable the model to memorize longer-term information. Instead of memorizing all information, Rehearsal Memory [509] is proposed to make the memory focus on the crucial information. These models can theoretically process documents with unlimited length, but how to generate informative memory is still challenging for existing models.

3. **Retrieval-based Models.** Inspired by the observation that many NLP tasks can be divided into several reasoning steps, and only a few sentences are needed to fulfill each reasoning step, some researchers regard the long document modeling task as the combination of key sentences retrieval and key sentences reasoning [510, 511]. These models rely heavily on the key sentences assumption and discard the semantic correlation between sentences.

4. **Discourse-enhanced Models.** Discourse structures are critical features for documents and are key differences between long document modeling and sentence modeling. Many sequence-level pre-training tasks have been proposed to integrate discourse knowledge into BLMs, such as the next sentence prediction [18], sentence distance classification [186], sentence reordering [350, 186, 512, 513]. These self-supervised training signals can help the model to capture the relation between sentences and further improve the performance in document modeling.

### 6.5.3 Multi-task Learning

Multi-task learning [514, 515] has been a long-standing method to improve both the effectiveness and efficiency of NLP systems. In the era of big model, numerous efforts have been spent on exploring the effectiveness of multi-task learning combined with pre-training. The explorations could be largely divided into the following three directions:

1. **Multi-task Finetuning.** In order to build an NLP system that could jointly solve multiple tasks, early works typically leverage the hierarchical task taxonomy to construct a hierarchical model architecture [516]. With the introduction of big models, multi-task learning renews a surge of interest. Researchers propose to utilize the versatile knowledge learned during pre-training and train a unified model that could perform well on various downstream tasks. Similar to human beings’ learning activities, when jointly trained with multiple tasks, big models could leverage the knowledge (task supervision) learned by other tasks to benefit a specific task. However, due to the imbalance of data sizes of different tasks, jointly training multiple downstream tasks may result in over-fitting on data-scarce tasks and under-fitting in data-rich tasks [517], making it hard to find a consistently good big model for all tasks. To this end, (1) some propose to build task-specific architectures based on shared universal language representations across various tasks, such as MT-DNN [518]; (2) others investigate the feasibility of hyper-networks [519] to dispense with task-specific finetuning tricks altogether. The hyper-networks could generate task-level and even instance-level parameters to solve a task; (3) in addition, some parameter-efficient algorithms are proposed to further reduce the newly-learned parameters needed for each downstream task, such as HYPERFORMER [520] and Projected Attention Layers [521]; (4) orthogonal to the aforementioned works that focus on neural architecture designing, researchers also propose Born Again Neural Networks [522] to learn a big model that could perform well on multiple tasks through knowledge distillation.

2. **Multi-task Pre-finetuning.** Instead of simultaneously learning multiple downstream tasks, some works propose to additionally adapt the big models utilizing intermediate tasks before finetuning on the specific target task of interest. The above process is dubbed as “pre-finetuning”. The corresponding explorations could be categorized into four types: (1) **exploring the effectiveness of pre-finetuning.** (a) By incorporating the intermediate stage of knowledge transfer, big models could gain sufficient language skills that are not included during self-supervised pre-training and achieve certain performance gains in downstream tasks [523]. For instance, some works have shown the superiority of the above routine in relation extraction [189], named entity recognition [524], text classification [525] and question answering [526]. The more evident performance gain is observed, especially under low-resource settings. (b) Besides conducting pre-finetuning on supervised small-scale datasets, another line of work conducts pre-finetuning on domain-specific unlabeled data and shows that additional adaptation towards a certain domain could provide significant benefits [77, 527, 528]. (2) **Understanding the success of pre-finetuning.** Although being effective, pre-finetuning is found to bring only marginal performance gains under some circumstances. In other words, the success of pre-finetuning is relatively sensitive to the chosen intermediate tasks. To understand this phenomenon, some works conduct sufficient empirical analysis to better understand (a) what kind of tasks tend to serve as good intermediate tasks [529] and (b) what kind of language skills do big models learn during pre-finetuning [530]. The above two research questions are also related to exploring the knowledge transfer among different NLP tasks. Some works pioneered to study the transferability for reading comprehension [531] and cross-linguistics [532], later works focus on analyzing the transferability across far more diverse tasks for both finetuning [533] and parameter-efficient tuning [534]. (3) **Efficient intermediate task selection for pre-finetuning.** Based on the transferability among different tasks, researchers also explore how to efficiently choose the most appropriate combinations of intermediate tasks from an abundance of candidate tasks through embedding-based methods [535], manually-defined features [532], task gradients [536] and Beta-Bernoulli multi-armed bandit [537]. (4) **The power of scale for multi-task pre-finetuning.** Furthermore, some works also indicate that the labor of intermediate task selection could be removed by conducting multi-task pre-finetuning at a sufficiently large scale with extremely diverse tasks [529], that is, when scaling the number and diversity of intermediate tasks, performance gains on target tasks are consistently observed. Others also show that pre-finetuning big models on diverse tasks, which are described as instructions, could substantially boost the performance of zero-shot cross-task generalization, even for extremely large big models [538].

3. **Unifying NLP tasks.** The past few years have witnessed the evolution of paradigm for various NLP tasks. In the meantime, the paradigm shift has also been observed in a growing number of NLP tasks [380]. Especially after the introduction of big models, some paradigms (e.g., the sequence-to-sequence paradigm) have shown the potential to unify various kinds of NLP tasks that differ a lot superficially with a single model. Compared with designing multiple task-specific models, a single unified model exhibits several advantages, including higher sample efficiency, better generalization, easier deployment and excellent robustness. The research explorations in task unifying could be categorized into 3 types: (1) prior explorations propose to **cast pre-training objectives into the format of specific downstream tasks**, e.g., question answering [539, 540], span prediction [301] and textual entailment [541]. In addition, the development of text-to-text big models such as T5 [19] achieves great success by treating every text processing problem as a “text-to-text” problem; (2) another line of work proposes to **cast various tasks into the form of pre-training tasks of big models**, especially after the success of the prompting methods [316], which insert human-designed / automatically-generated tokens into the input text to mitigate the gap between the formats of downstream finetuning and pre-training. Prompting makes it possible to solve various understanding and generation tasks using a single big model backbone [315, 327, 144]; (3) **understanding the principle of task unification.** Despite the success of the above explorations, it is still under-explored why different NLP tasks that differ a lot superficially could be potentially unified into the same format. Recently, researchers find evidence indicating that the adaptations of a

big model to various downstream tasks can be reparameterized as optimizing only a few free parameters in a unified low-dimensional parameter subspace [329], providing the possibility of the transferability among different tasks. In other words, solving different tasks requires limited combinations of the language skills conserved in the big model, and such language skills of different tasks may have a large overlap.

#### 6.5.4 Continual Learning

Human beings excel at learning knowledge in a lifelong manner. On the one hand, they can make full use of the experience derived from other related tasks to learn new tasks. This knowledge transfer across different tasks plays a vital role in learning generalization, even in those scenarios where data is scarce [542]. On the other hand, human beings have strong memory abilities, so that after learning new knowledge, they will not easily forget old knowledge and can even further abstract the diachronic knowledge to enhance the abilities to solve various tasks [543]. That is to say, incrementally acquiring, refining, transferring, and remembering knowledge, is the cornerstone of human beings' powerful learning abilities.

In view of this, many efforts have been devoted to exploring continual learning in the field of NLP. Especially after the emergence of big models, continual learning has become more important and meaningful, because big models are pre-trained on the streaming data of various domains that are continuously increasing rapidly, and this learning process is quite similar to the learning process of human beings. These efforts mainly focus on the following directions:

1. **Alleviating Catastrophically Forgetting.** The problem of catastrophic forgetting [544] is a common phenomenon encountered in continual learning. Specifically, every time new data appears, continually learning this new data may let models overfit the local data and gradually lose the knowledge learned on the historical data. A straightforward solution is to store all historical data and re-train models every time new training examples come in. Nevertheless, the huge example number of historical data makes frequently mixing new and old examples become infeasible in the real world. Therefore, how to effectively learn new data and meanwhile efficiently avoid forgetting old data is a major challenge for continual learning.

Towards alleviating catastrophic forgetting, many researchers explore parameter regularization [545, 546, 547, 548, 549]. In the process of learning new data, these regularization methods regularize those parameters important to handle historical tasks and reduce their learning weights to alleviate the forgetting problem. Memory replay [550, 551, 552, 553, 554, 555] is another effective way to overcome the problem of forgetting. These memory-based methods will memorize a few examples of historical data and continually learn them with emerging new tasks to alleviate catastrophic forgetting.

As the parameter regularization methods do not require to remember any data, these methods are widely used for big models [556, 557]. Compared with those parameter regularization methods, the memory-based methods are more suitable for dealing with the forgetting problem in the process of continually learning specific tasks and are widely used in various tasks of text classification and information extraction [558, 559, 560, 561, 562, 563, 564, 565].

2. **Absorbing Historical Knowledge.** The target of continual learning is to continually absorb and organize fresh knowledge from new data. Although this process can be somewhat straightforwardly implemented by proceeding training on newly collected data, there are still two challenges remaining: First, since the incoming data may contain low-quality or duplicated information, we require to filter the new data to ensure that models can be learned effectively and efficiently based on the historical knowledge; Second, with tremendous knowledge in the past increasingly piled up, it is unavoidable that models may encounter "knowledge saturation", which means models may not hold such huge amount of information anymore, and models require to be expanded; Third, the knowledge learned on old data may be useful for learning new data. In summary, continual learning requires considering how to absorb historical knowledge.

Some preliminary works explore various dynamic model architectures [566, 567, 568], which can dynamically expand model architectures to learn new tasks and effectively prevent forgetting old tasks. Yet model architectures dramatically changing with increasing tasks makes these methods unsuitable for NLP applications in practice. Under this circumstance, some other efforts explore dynamically enlarging the original model (e.g., hidden size, number of layers, etc.) while retaining most of the original parameters when necessary. Enlarging the model size can effectively enjoy the benefits of historical knowledge as demonstrated by [20] and [569], and achieve better zero-shot/few-shot abilities and higher training efficiency. The dynamically enlarging model size has been used to pre-train big models [570], and achieved promising results. Moreover, Qin et al. [527] further propose "knowledge inheritance" to continually absorb knowledge from existing trained big models to learn larger and better big models.

3. **Updating/Correcting the Outdated Knowledge.** Much knowledge comes with an expiration date. It leaves the question of how to efficiently identify such outdated knowledge and correct it in time. In fact, existing parameter regularization, memory-based, and knowledge absorbing methods cannot handle this problem, since these methods frequently update model parameters, and it is difficult to grasp the parameters on which specific knowledge depends.

Recently, prompt tuning has been proposed, which will freeze big models and only tune task-specific prompts for downstream tasks [328, 571, 333]. Based on prompt tuning, we can update and correct the outdated knowledge in the process of continual learning. Continually updating the prompt templates implanted in the pre-training phase in order

to adapt to new future tasks when necessary. Along with continual learning, the parameters of big models are also continually updated, which means that those prompts tuned based on historic parameters may fail based on the latest version of big models. Therefore, it is meaningful to ensure that the prompts tuned on historic parameters can continue to work on new models, which has been demonstrated in the paper [572].

### 6.5.5 Knowledge-enhanced NLP

Knowledge is essential to the deep understanding of natural language. Therefore, many efforts have been devoted to integrating rich knowledge into big models for better language understanding, including world knowledge [162,163], linguistic knowledge [180,392] and commonsense knowledge [168,573]. To this end, researchers have explored integrating knowledge via three key components of big models, including model inputs, model architectures and objective functions. For the model inputs, knowledge augmentation aims to enhance the inputs with abundant related knowledge [162,412]. For the model architectures, knowledge support aims to design knowledgeable modules to support knowledge processing [573,510]. For the objective functions, knowledge regularization enhances the objective with knowledge to regularize the model representations [163,189]. Enhanced with rich knowledge, big models can typically achieve superior performance on a variety of knowledge-rich NLP tasks, such entity typing [162], information extraction [163], question answering [574] and dialogue systems [573]. We refer readers to Section 3 for a more detailed discussion on knowledge-guided big models.

### 6.5.6 Model Acceleration

Since the size of big models has been increasing exponentially in recent years [18,20], it is essential to explore the techniques of model acceleration for real-world application. The goal of model acceleration is to reduce the time and space complexity of big models for faster inference and deployment on resource-constrained devices. There are several techniques for model acceleration, including parameter sharing [294], model pruning [575,476,576], knowledge distillation [293,577,295], model quantization [578,579], dynamic inference [580,581,479].

1. **Parameter Sharing.** Sharing parameters across similar units can reduce the space complexity of big models. ALBERT [294] uses factorized embedding parameterization and cross-layer parameter sharing to reduce the parameters of BERT. Using the same parameters across all Transformer layers, ALBERT achieves a significant parameter reduction, and meanwhile has the same or even better performance. This indicates that big models can be over-parameterized, and there is much room for optimization.

2. **Model Pruning.** To take more advantage of the over-parameterized feature of current big models, researchers also explore model pruning, which cuts off some useless parts in big models to reduce the computation cost while maintaining the performance. For layer pruning, Fan et al. [582] selectively drop layers during training and dynamically combine parts of layers for a more shallow model during inference. For the pruning of attention heads, researchers find that only a small part of them is enough for good performance [575,476,576]. Most of these heads can be removed with little impact on the accuracy. Other trials such as CompressingBERT [480] try to prune the weights of both attention networks and feed-forward networks to reduce the number of parameters in s and find that the redundant weights are less than 50%, which is different from the redundant ratio of CV models (over 90%).

3. **Knowledge Distillation.** The goal of knowledge distillation is to train a small student model with the supervision of a large teacher model having good performance. Using a small distilled model for inference can reduce both the time complexity and the space complexity. There are some typical works on knowledge distillation for big models, such as DistillBERT [293], TinyBERT [295], BERT-PKD [577] and MiniLM [583]. They propose to use various supervision from teacher models, including the output probability, the hidden states, and the attention matrices. Meanwhile, the student model can learn from a big model or a fine-tuned model. Compared to training a small model alone, knowledge distillation can utilize the knowledge stored in teacher models to increase the performance of student models. However, knowledge distillation is limited by the access to teachers' training data and the computation cost of teacher models. These methods require the data used for pre-training the teacher model, which is usually not released in consideration of the data copyright and privacy. And, the teacher model needs to compute the entire pre-training data to produce logits or intermediate representations for knowledge distillation, causing an even longer training time.

4. **Model Quantization.** To further accelerate big models, researchers explore model quantization, which has been widely used in CNN-based models [584]. Model quantization refers to converting higher-precision floating-point parameters to lower-precision ones. The parameters of conventional big models are usually represented in 32 bits or 16 bits, while parameters after quantization can be represented in 8 bits or even 1 or 2 bits. Recently, 8-bit quantization has been proved to be effective for model compression in Q8BERT [578] without significant performance degradation. Despite this, training 1 or 2 Bits models remains challenging due to the significant decrease in model capacity. To alleviate the performance degradation, other methods to preserve the accuracy can also be employed. Q-BERT [585] uses mixed-bits quantization where the parameters with higher Hessian spectrum require higher precision, and those

parameters with lower Hessian spectrum need lower precision. TernaryBERT [579] applies knowledge distillation in quantization, forcing low-bit models to imitate full-precision models. Both Q-BERT and TernaryBERT result in ultra low-bit models. However, low-bit representation is a highly hardware-related technique, which means quantization requires specific hardware and can not generalize to all devices.

5. **Dynamic Inference.** Most work focuses on how to dynamically drop layers to accelerate inference [580,581]. In this manner, the output of each layer is expected to be able to predict labels, and hence it will introduce additional training objectives and prediction strategies. Meanwhile, MoEfication [479] propose to dynamically select parts of feed-forward networks, which simplifies models in a finer granularity and does not change the process of training and inference.

## 6.6 Future Directions

For human beings, understanding complex semantics at different levels requires various knowledge. With the knowledge at different levels, we can capture rich information from the text and give diversified responses. Looking back at the research spectrum of NLP, to a certain extent, what we have been doing is researching how to let machines obtain all kinds of knowledge required for language understanding. These crucial “knowledge” includes both the symbolic knowledge used in the grammar theory [586,587] and the expert system [588,589], as well as the model knowledge used in the statistical learning [590,379] and deep learning [61,591]. In recent years, after the emergence of big models [18,26], using self-supervised learning methods to obtain versatile knowledge from large-scale unlabeled data, and then fine-tuning these big models to adapt the pre-trained knowledge to downstream tasks has become a new paradigm in the field of NLP. Making full use of knowledge, whether it is symbolic knowledge or model knowledge, is a crucial way towards better language understanding. From the perspective of utilizing knowledge, several directions may be promising in the future:

**Knowledge augmentation to augment the input of models with knowledge.** There are two mainstream approaches for knowledge augmentation. One is to directly add knowledge into the input and mainly used for symbolic knowledge [181,592,408]. These methods retrieve background knowledge and then add the knowledge into the input sequence to provide more information for models. The other approach is to design special modules to fuse the original input embeddings and the knowledgeable input embeddings, which are mainly used for model knowledge [593,594,290]. The model knowledge can provide rich implicit knowledge to make the input more informative.

**Knowledge support to support the processing procedure of models with knowledge.** On the one hand, we can use knowledgeable underlying model layers for pre-processing to make features more informative [595,596,462]. On the other hand, knowledge can be also used as an expert at the top of models for post-processing, guiding models to calculate more accurate and effective output [192,66,597,598,180].

**Knowledge regularization to regularize the objective function of models with knowledge.** Using knowledge to build extra objectives and regularization functions, especially weakly-supervised methods [599,162,163,392], has shown promising results to enhance model performance. Besides, using knowledge as extra predictive targets for the training process [600,601,164] is also promising. Knowledge distillation [602] is a representative approach for this, which uses model knowledge as extra predictive targets.

**Knowledge transfer to obtain a knowledgeable hypothesis space with knowledge,** making it easier to train an effective model. Both transfer learning [12] and self-supervised learning [603], which focus on transferring knowledge from source tasks to downstream target tasks, are typical approaches for this. In fact, knowledge transfer is widely used in NLP. Recently, fine-tuning big models such as GPT [26] and BERT [18] has shown promising results, owing to the effectiveness of knowledge transfer.

**Knowledge container based on big models.** As we mentioned before, big models could capture rich model edges from large-scale textual corpora, and fine-tuning big models with extra task-specific data can transfer big models’ knowledge to handle downstream tasks. Recently, prompt tuning[604,605,146] has been further proposed to utilize the knowledge in big models efficiently, and has drawn a lot of attention. [144,319] further explore to freeze the whole big models and only tune soft prompts to adapt big models to handle downstream big models. When the model parameters reach a certain scale, only tuning soft prompts can achieve comparable results to fine-tuning all model parameters. In other words, we can fix big models as knowledge containers, and learn task-specific prompts to extract and store knowledge for specific tasks.

## 7 Big Vision Models

*Authors: Yongming Rao, Wenzhao Zheng, Wenliang Zhao, Ziyi Wang, Borui Zhang, Jiwen Lu<sup>✉</sup>*

---

Jiwen Lu (lujiwen@tsinghua.edu.cn) is the corresponding author of Section 7.

With the rapid development of artificial intelligence, the computer vision field has witnessed significant progress in both theoretical research and practical applications. Delicately designed deep models with the abilities to perceive the visual world and process various downstream vision tasks are leading a unprecedented revolution to many aspects of the modern information society, such as intelligent robotics and autonomous driving. However, the growing appetite for data of ever-enlarging deep models has also brought challenges to further advancement of the community, as the annotation cost for numerous task-specific data and the corresponding training resource expenses are unaffordable. Therefore, the pre-training technique is then introduced to bridge the gap between the training resource limitations and demands for higher representational ability of vision features.

The vanilla pre-training strategy [606] is composed of two steps: (1) pre-train a visual feature perception model on an immense and easily-labeled database, and in turn (2) finetune the weights on the target task based on a smaller and precisely-annotated downstream dataset. The second stage typically takes less gradient descent optimization to converge and achieves better results than the one training from scratch, since the pre-training stage has enhanced the feature extraction capability of the backbone. The paradigm has been dominating many data-starving vision problems, such as object detection and segmentation. However, there are still many underlying challenges. On the one hand, the domain discrepancy between the pre-training database and the fine-tuning task-specific dataset has been an obstacle for better knowledge adaptation. On the other hand, the supervision collapse [607] occurs when the pre-trained model focuses on a limited range of information and neglects components that are essential for downstream tasks but contribute little to the pre-training objective. Additionally, the architectural gap and the information density divergence between the pre-training mission and downstream tasks are also existing technical challenges for vanilla vision pre-training.

To overcome the aforementioned difficulties, more complicated pre-training schemes are promoted to focus on exploiting more comprehensive knowledge from the data via multifarious pretext tasks. In-painting [608], colorization [609], de-shuffling of image patches [610], masked image modeling [611] are representative ones and denoising autoencoders [612] are designed to restore the original images from these handcrafted puzzles. The high-level features from the autoencoders are regarded as concentrated image representations and are transferred to downstream tasks. Moreover, contrastive learning [613], unsupervised clustering [614] approaches are also potent pre-training techniques. These unsupervised or semi-supervised pre-training strategies are raising more and more attention of researchers given their low requirement for precise labels.

The development of pre-training studies is critical to vision evolution, both theoretically and practically. For academic research, pre-training is an important representation learning topic to investigate how to extract more representative features that can not only better perceive the visual world, but also be easier to transfer to downstream tasks. For industrial applications, the pre-training technique fulfills the appetite of data-starving models of the downstream tasks with limited annotated data, and enables the deep model to consume less training resources. Thus it makes the deep model more applicable to industrial scenarios, such as robotic manipulation and autonomous driving. In conclusion, pre-training is one of the keys to more advanced deep models for computer vision and artificial intelligence.

In this section, we will thoroughly summarize the existing literature on pre-training in vision.

- Section 7.1 first goes over architectures of vision models, that are foundations of the pre-training strategy design.
- Then in Section 7.2, we will review various pre-training strategies that are divided into three categories according to the supervision degree.
- The following Section 7.3 presents downstream tasks that the pre-trained models are applied to.
- Finally, we conclude the section in Section 7.4 and introduce future directions of pre-training in vision.

## 7.1 Architectures of Vision Model

### 7.1.1 Deep Convolutional Neural Networks

CNNs have been the dominant architectures in computer vision since their breakthrough on image classification [2]. Different from previous methods like MLPs (multi-layer perceptrons) and those based on handcraft features, CNN enjoys powerful feature extraction ability with relatively lower computational complexity. The basic operation in CNN is convolution, which captures the local patterns via a kernel shared on all spatial locations. Downsample layers are usually adopted to reduce the size of feature maps and enlarge the reception field. Fully-connected layers are used at the end of the network to obtain the final classification scores. The significant improvements brought by CNNs suddenly attracted the computer vision community's attention, which then led to the enormous progress in the architecture designs of the CNNs in recent years. As the winning solution of ImageNet 2012 competition, AlexNet replaced the commonly used average pooling to overlapping max pooling and is trained with more powerful data augmentation methods on two GPUs. VGGNet [615] proved the superiority of deeper networks and proposed some new principles for architecture design such like the  $3 \times 3$  convolutions. GoogLeNet [616] proposed the Inception module which applied

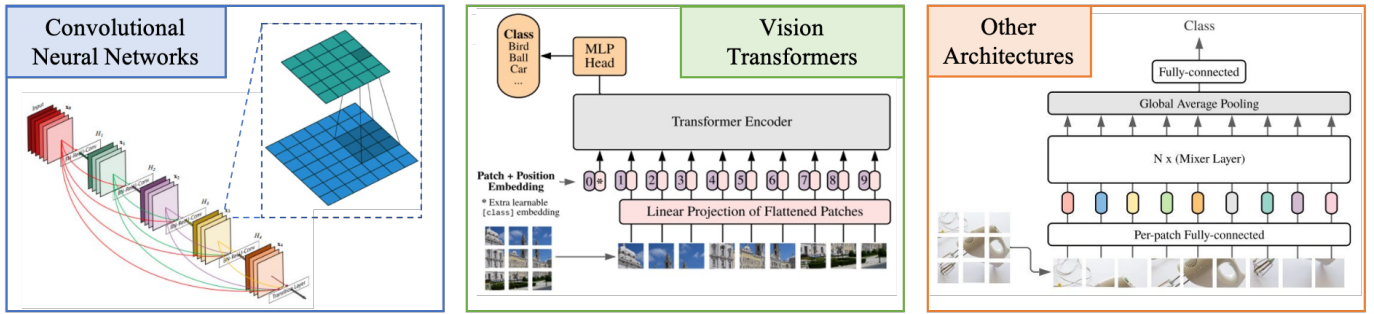

Fig. 19. Architectures of Vision Model.

$1 \times 1$ ,  $3 \times 3$ ,  $5 \times 5$  convolutional kernels to extract feature maps from different scales. One of the most representative architectures of CNNs is ResNet [617], the winner of the ILSVRC 2015 image classification and object detection. ResNet resolved the optimization problems of deeper models by adding a residual connection in each block. A bottleneck block is also introduced to reduce the number of parameters. The simple implementation and the promising performance makes ResNet remain to be the most commonly used architecture nowadays. Apart from the architectures aforementioned, there are also some lightweight networks specifically designed for mobile devices such as MobileNets [618,619] and ShuffleNets. In MobileNets series, depth-wise separable convolutions, inverted residual blocks, neural architecture search (NAS) are proposed or introduced to reach better accuracy-complexity tradeoffs. ShuffleNets [620] adopted pointwise group convolution and channel shuffle to build a series of hardware-friendly architecture.

### 7.1.2 Vision Transformers

Although CNNs have become the standard architecture for computer vision, recent advances have demonstrated that Vision Transformers (ViTs) are powerful alternatives. ViT treats an image as a series of tokens and borrows the successful Transformers in NLP to model the interactions among the tokens. Specifically, ViT [28] first split the image into multiple non-overlapping patches, and then use linear projections to convert the flattened patches to visual tokens. The visual tokens are then concatenated with a class token to form the inputs for the Transformer. Position embeddings are applied to include information on spatial locations. The self-attention mechanism can capture long-term dependencies without introducing inductive bias like convolutions. Experiments show that ViT achieves better performance, especially when pre-trained on larger datasets like JFT 300M. DeiT [621] proposed a data-efficient training recipe and distillation strategy which can largely enhance the performance of ViTs when only regular datasets like ImageNet are available. However, standard vision transformers can only process relatively small feature maps (e.g.,  $14 \times 14$ ) due to the quadratic complexity of self-attention. As a result, they cannot be applied to downstream tasks including object detection and semantic segmentation, where hierarchical feature maps are required. Swin [29] resolves this issue by applying self-attention in small windows. Normal windows and shifted windows are used alternatively to enlarge the inception field. Swin achieves state-of-the-art results on multiple tasks, which also proves that vision transformers have good generalization ability on downstream tasks. For example, DVT [622] adjusts the number of input tokens according to whether the sample is easy or hard. DynamicViT [623] uses predictors to compute the keeping probabilities of the tokens and dynamically discards less important tokens to achieve token specification.

### 7.1.3 Other Architectures

Some recent works have proved that convolutions and self-attentions are complementary [624]. Borrowing the merits from both CNNs and ViTs, it becomes a new direction to build hybrid models that consist of both convolution and self-attention. For example, CoATNet [625] experiments with many combinations and find some basic principles to construct such hybrid architectures given different dataset sizes. MLP-Mixer [626] and ResMLP [627] are another two simple architectures that directly replace the self-attention layers in vision transformers with spatial MLPs. However, despite the simplicity of the all-MLP models, they are still hard to be scaled up to higher resolution. To this end, GFNet proposes to use a global filter layer to replace the self-attention, which can be simply implemented as a stack of a 2D FFT, an element-wise multiplication, and an inverse 2D FFT. Experimental results show that GFNet [628] can not only enjoy better accuracy-complexity trade-offs but also achieve better performance on downstream tasks.



## 7.2 Pretraining Strategies

In this section, we classify pre-training strategies for vision models into supervised pre-training, unsupervised pre-training, and semi-supervised/weakly-supervised pre-training according to the degree of utilization of human-annotated information.

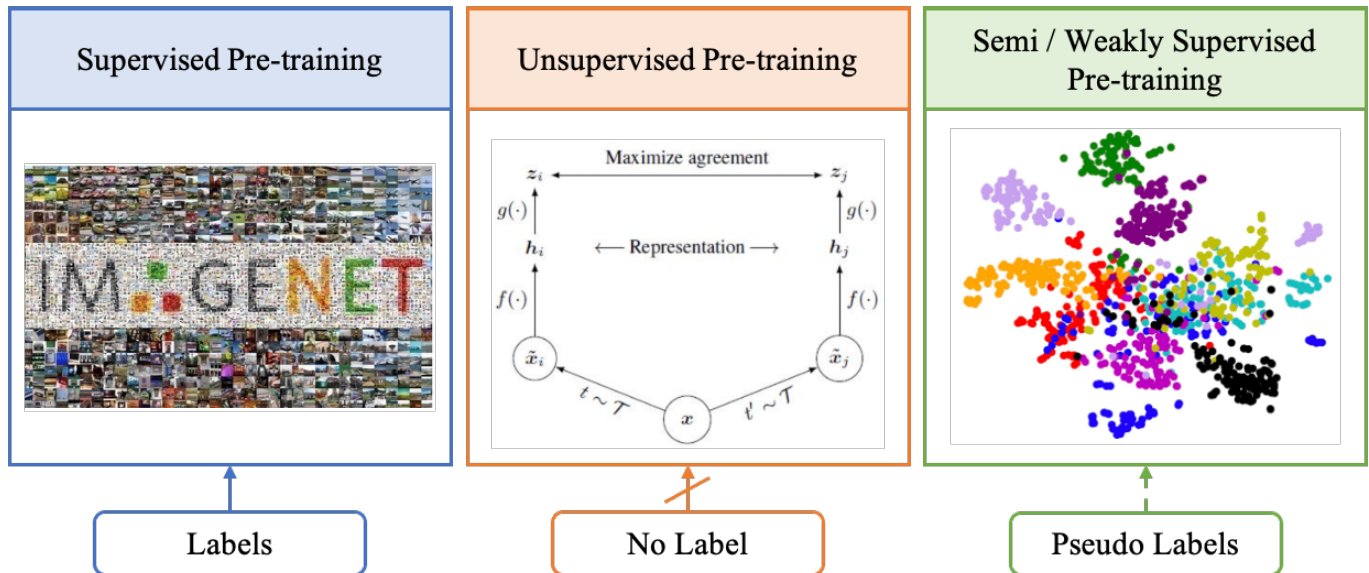

Fig. 20. Pretraining Strategies of Big Vision Models.

### 7.2.1 Supervised Pretraining

Supervised pre-training is the most basic and common pre-training strategy for vision models. Supervised pre-training requires clear and complete annotation of the dataset, and uses manual annotation information to guide model parameter training.

In 2009, Deng *et al.* published the ImageNet dataset [10], which is a large-scale supervised training dataset commonly used in recent years. In 2012, Krizhevsky *et al.* proposed the multi-layer convolutional neural network AlexNet [2], which was an earlier method that achieved considerable performance using supervised training on the ImageNet dataset. Achieving the local sparse structure through the fusion of different scale features, Szegedy *et al.* proposed the GoogLeNet [616] with a deeper convolutional network layer, which further improves the classification accuracy of supervised training on the ImageNet dataset. At the same time, He *et al.* proposed the new activation function and initialization method [629] and facilitated the supervised training of deeper network structures. The classification accuracy on the ImageNet dataset exceeds the human level for the first time. To solve the problem of gradient disappearance in deeper networks, He *et al.* proposed ResNet [617] with residual connection structure to further improve the performance of ImageNet supervised training. In addition to the convolution-based network structure, Dosovitskiy *et al.* verified the feasibility of the attention-based visual transformer structure for supervised training [28]. Through the design of window division and window sliding, Liu *et al.* proposed Swin Transformer [29] to reduce the computation complexity of self-attention interaction in ViT and achieved excellent performance in the three tasks of image classification, object detection, and semantic segmentation. Thus Swin Transformer becomes the current new supervised pre-training benchmark model.

Since supervised pre-training relies heavily on human annotation information, some researches have begun to use larger-scale labeled datasets to explore the possibility of larger-scale supervised pre-training. Zhai *et al.* explored the supervised pre-training performance of the ViT model on the unpublished large-scale dataset JFT-3B dataset [630], which is an annotated dataset containing 3 billion images. For the first time, the classification results of this pretrained model on the ImageNet dataset exceeded 90%. At the same time, Riquelme *et al.* adopted the design idea of the mixture of experts and constructed a ViT-MoE [631] model with 14,700M parameters. With the help of the supervised training of the JFT-3B dataset, the classification accuracy rate on the ImageNet dataset was also over 90%. Liu *et al.* extended Swin Transformer [29], proposed a Swin-v2 [632] model with 3B parameters, conducted supervised pre-training experiments by introducing the unpublished ImageNet-22K-ext dataset, and also achieved a classification accuracy rate of over 90% on the ImageNet-1K dataset.

### 7.2.2 Unsupervised Pretraining

Since it is difficult to manually label large-scale datasets, how to make full use of unlabeled data has become a current research hotspot. Unsupervised pre-training only uses datasets without manual annotation and introduces special model designs or optimization goals combined with human prior knowledge to achieve model pre-training. According to the way to provide model pre-training prior knowledge, it can be divided into self-supervised pre-training, cluster-based pre-training, and pretext-task-based pre-training.

Self-supervised pre-training is a common unsupervised pre-training algorithm. The core idea is to use the consistency of the views obtained after different transformations of the same image to train the model. In 2014, Dosovitskiy *et al.* first tried image augmentation methods such as rotations, transformations, color changes, or contrast adjustments on randomly sampled image patches [633], and constrained the network to correctly classify different views from the same image patch. Hjelm *et al.* proposed Deep InfoMax [634], which uses the consistency of local features and global features of the same image for self-supervised pre-training. In 2020, He *et al.* proposed MoCo [613] and MoCo-v2 [635] to greatly improve the classification performance of the self-supervised pre-training method on the ImageNet. The algorithm reduces memory overhead by introducing an asymmetric memory bank structure. In the same period, Chen *et al.* proposed SimCLR [190], which further increases the performance of self-supervised pre-training by introducing more image augmentation methods. Grill *et al.* proposed BYOL [636], an asymmetric algorithm with an online and a target network to avoid training collapse. Chen *et al.* integrated mainstream self-supervised pre-training algorithms in 2021 and proposed a simplified SimSiam [344], which only uses asymmetric projection heads and positive sample pairs to achieve high-performance self-supervised pre-training.

With the use of deep neural networks, cluster-based pre-training algorithms have become one of the mainstream research directions for unsupervised pre-training. In 2016, Xie *et al.* used an encoding network to represent images as low-dimensional features and then used a given target distribution to guide the network for unsupervised clustering [637]. In 2018, Caron *et al.* proposed DeepCluster [614], which iteratively uses the K-Means algorithm [638] to generate pseudo labels, and uses pseudo labels as supervision signals to train network parameters. Then, in 2020, Caron *et al.* proposed SwAV [639], which clusters the data while imposing the same feature consistency constraints on different views. At the same time, Gansbeke *et al.* proposed SCAN [640], which achieves unsupervised clustering by mining nearest neighbor samples with the help of self-supervised tasks.

In addition to this, there is a large class of unsupervised pre-training methods that employ pretext tasks to train networks. The so-called pretext task is a task that can assist in training the network although it is different from the target task. In 2015, Doersch *et al.* proposed to use the context prediction as the pretext task [641]. Inspired by BERT [642], the BEIT [643] and the MAE [611] employed the masked patch completion task as a pretext task to train the network and achieved the high classification performance on the ImageNet.

### 7.2.3 Semi/Weakly-supervised Pretraining

Semi/Weakly supervised pre-training is aimed at training models with fewer or weaker human annotations. Semi-supervised pre-training can be regarded as a combination of supervised and unsupervised pre-training, which can utilize both labeled and unlabeled data to train the model. Weakly supervised pre-training employs supervision information which is easier to obtain than manual annotation.

One of the main ideas of semi-supervised pre-training is to use models trained on the labeled data to assist training on the unlabeled data. In 2013, Lee *et al.* proposed a method of using labeled data to train a model and then using the current model to generate pseudo labels to further promote training on unlabeled data [644]. Tarvainen *et al.* proposed the Mean Teacher [645], which uses a teacher based on the average weights of a student in each update step. Berthelot *et al.* unified the dominant approaches and proposed MixMatch [646], which predicted low-entropy labels for data-augmented unlabeled examples and mixes labeled and unlabeled data using MixUp [647]. By employing datasets with larger scales and models with more parameters, the performance of semi-supervised pre-trained models can be further improved. Xie *et al.* proposed Noisy Student [648], which achieves 88.4% top-1 accuracy on ImageNet. First, they train an EfficientNet model on labeled ImageNet and employ it as a teacher to predict pseudo labels on 300M unlabeled images and train a larger EfficientNet as a student model on the combination of labeled and pseudo labeled data. Such a process is iterated by putting back the student as the teacher, which gradually generates the less noised teacher. Pham *et al.* proposed Meta Pseudo Labels [649], which achieves a new state-of-the-art top-1 accuracy of 90.2% on ImageNet compared with other semi-supervised methods. Different from Pseudo Labels [644], the teacher in Meta Pseudo Labels is constantly adapted by the feedback of performance of the student on the labeled dataset.

Weakly-supervised pre-training mainly employs supervision that is more convenient to obtain than fine annotation to train the model, which tends to have weaker supervision ability and may be mixed with noise. In 2018, Mahajan *et al.* explored the behavior of pretraining with 3.5 billion public Instagram images [650]. Due to the difficulty of large-scale manual annotation, they employed the social media hashtags in the wild as the supervision, which may be mixed with some noise. The experimental results demonstrate the excellent transfer learning performance only trained

with weak supervision by hashtags. Radford *et al.* proposed CLIP [651], which trains models directly from raw texts about images without manual annotations. They demonstrate that it is efficient and scalable to learn excellent image representations by training models to match captions and images.

### 7.3 Applications of Big Vision Models

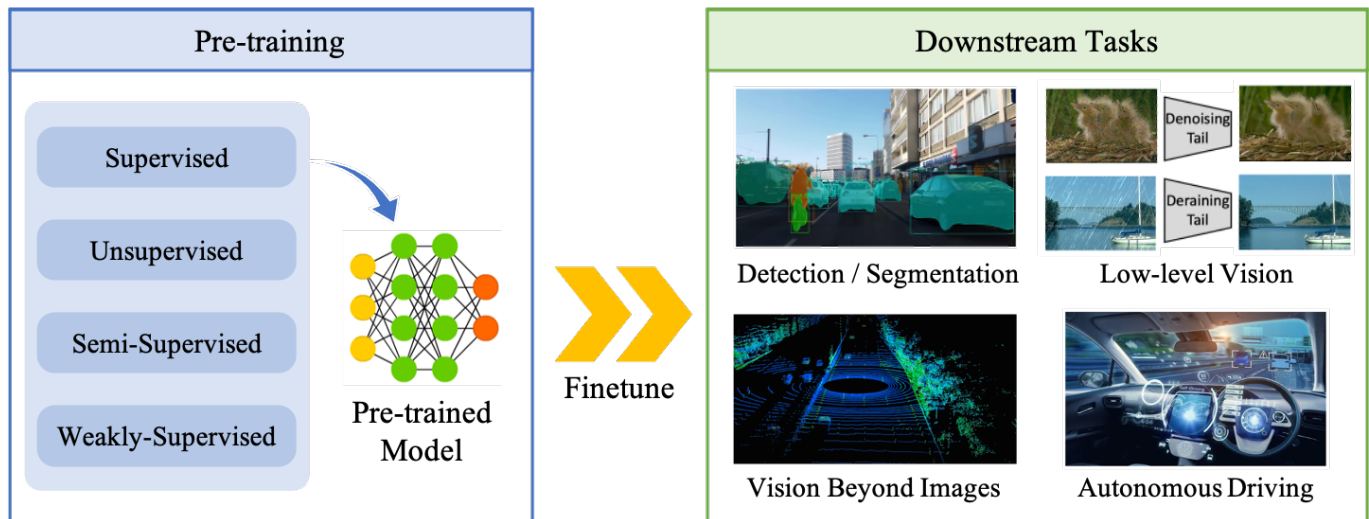

**Fig. 21.** Applications of Big Vision Models.

In this section, we discuss the application of big vision models on several downstream tasks including object detection and semantic segmentation, low-level vision, vision understanding beyond images, and visual perception for autonomous vehicles and robotics.

#### 7.3.1 Object Detection and Segmentation

Object detection and semantic segmentation are two most common downstream tasks for computer vision. The task of object detection is to identify object locations and classify objects in these locations. Different from classification which performs classification in the image level, object detection performs classification on the region level. Since the quality of extracted features is important for the classification of regions, the pretraining of the model has a large effect on the performance of object detection. Using a better pretrained backbone network achieves considerable better results than training from scratch. A common pipeline is to first pretrain a big vision model on ImageNet and then finetune this network for detection. They usually incorporate the big vision model to a detection framework (e.g., Cascade Mask R-CNN [652], RepPoints [653], and Sparse RCNN [654]) and use multi-scale training [655,654]. Both CNNs (e.g., ResNet [617]) and ViTs (e.g., Swin [29,632]) can be used as the backbone network, which achieves excellent performance.

The task of semantic segmentation is to classify each pixel of an image and is thus a dense classification task. For example, Mask R-CNN [656] formulates segmentation as a mask classification problem and generates masks based on detected bounding boxes. Maskformer [657] performs mask classification based on set prediction and achieves state-of-the-art performance. Still, using a pretraining backbone big vision model improves the performance of segmentation and a larger vision model pretrained with more data typically achieves better performance. The backbone model itself typically has a larger effect on the performance than the segmentation framework.

#### 7.3.2 Low-level Vision

With the improvement of stochastic hardware level, big models (such as BERT [642], GPT-3 [20]) pre-trained on large datasets have shown better effectiveness than traditional methods. The great progress of transformer is mainly due to its powerful feature expression ability, which is also the key factor to low-level computer vision tasks such as image denoise [658], super-resolution [659], and image deraining [660]. Image Processing Transformer (IPT) [661]

takes advantage of the representation ability of vision transformer to jointly address multiple low-level vision tasks to improve the performance. They employ multiple heads and multiple tails to adapt to a variety of degradation models. In order to maximize the ability to mine transformers, they use the ImageNet dataset to produce a large number of degraded image data pairs and then use these training data pairs to train the IPT model. In addition, they also introduce contrastive learning [190] to better adapt to different image processing tasks. After fine-tuning, the pretrained big vision model can be effectively applied to multiple tasks. With only one pretrained big vision model, IPT can outperform the SOTA frameworks on multiple low-level vision benchmarks.

### 7.3.3 Vision Understanding Beyond Images

As a single sensor can hardly capture all the information, modern vision systems capture different modalities of visual signal and process video to take temporal relations into consideration.

For the training of video-based big vision model, the temporal correlations among frames provide a natural supervision. In recent years, self-supervised learning has attracted extensive attention especially on large-scale unlabeled data. Using temporally continuous data such as video, Salakhutdinov et al. [662] proposed a method of predicting post-sequence frames based on pre-sequence frames of videos, so that the model can learn the video sequences in the video scene. Mirsa et al. [663] proposed a self-supervised learning task of judging the correct temporal position of the input frame to extract more video-related features. Vondrick et al. [664] of Google Research proposed a self-supervised task of coloring videos based on the self-similarity of adjacent frames, which obtained richer feature representations and achieved good video segmentation effects without fine-tuning. Qian et al. [665] later proposed a contrastive learning method based on video spatiotemporal self-similarity, and obtained a richer and more complete feature representation based on video. Recently, Li et al. [666] proposed a video contrast learning method based on motion alignment, which achieved better results than other self-supervised learning methods on the downstream task of action recognition.

Another widely-used visual modality is the point clouds collected by LiDARs, which are composed of a set of points with 3D coordinates. Point clouds provide more structural information than RGB images due to the access of depth while lacking semantic information. Early methods [667] first transform point clouds into voxels or multi-view images and then employ 3D CNNs or 2D CNNs to extract features. PointNet [668] and PointNet++ [668] directly extract features from raw point clouds and achieve better performance and efficiency. Recently, vision transformers [28] are introduced to 3D perception to better exploit the structural information between points. Furthermore, Omnivore [669] process images, video, and 3D data with a single model, which first transform them into an embedding space and then employ a shared transformer architecture to extract more comprehensive features.

### 7.3.4 Visual Perception for Autonomous Vehicles and Robotics

As the main source of perception for humans, visual perception also serves as the most important sensor for autonomous vehicles and robotics. Two prevalent frameworks for autonomous vehicles are fusion-based [670] and vision-based [671]. Fusion-based schemes [670] collect information from multiple source like cameras, LiDARs, and radars and then fuse them to make decisions. Differently, vision-based schemes [671] only utilize RGB images as the input visual source, similar to humans, for further decision-making process. Even though vision-based schemes are usually more efficient, compared with the model based on 3D point cloud, there is still a big gap in the performance of 3D scene perception based on image and video [672]. However, sensors such as lidar to obtain 3D point clouds are expensive to fake, and different types of lidar data are distributed differently, making it difficult for a single model to generalize to different 3D point clouds. In addition, the current research on large-scale visual models in terms of parameter quantity, training and deployment efficiency, and industrialization has a huge gap with language large-scale models, which is far from meeting the needs of the industry [673]. Therefore, how to effectively extract accurate 3D information from multi-view images is crucial to the performance of the model. In addition, training a multi-view 3D information extraction model requires a lot of data, but 3D detection, 3D semantic segmentation and other annotation acquisition costs are high and the amount of data is small, which cannot support the effective training of big vision models.

## 7.4 Future Directions

Despite the remarkable progress in developing large-scale vision models in recent years, there are still several challenges associated with the downstream applications of big vision models. One of the most important bottleneck is the lack of a general-purpose large-scale model that can process information from various forms of visual data and conduct various downstream tasks. There have also been some challenges to deploy vision models to edge devices for real-world applications. Designing models with more flexible architectures with better interpretability are also emerging topics to build reliable, efficient and robust big vision models. In this section, we highlight a few promising directions to tackle these challenges and expand the future applications of big vision models.

### 7.4.1 Generic Modeling of Visual Data

Different from natural language understanding tasks that have a unified form of input data (i.e., a sequence of words), vision tasks usually perform on a wider range of visual data including images, videos, 3D point clouds, etc. Most existing big vision models are designed for a single form of visual data, which makes them difficult to transfer to other visual tasks and thus limit their applications in downstream tasks. This design is also divergent from biological systems that can process various modalities. Recent efforts on vision Transformers offer a new direction to unify different forms of visual data and downstream tasks. Different convolutional models that are specifically designed for visual data, previous studies have shown that Transformer architectures can be successfully applied to various domains, data forms and tasks. Thanks to the progress of exploiting Transformer architectures in vision tasks, Jaegle et al [674] propose the Perceiver that aims to learn a unified models for different forms of data without the inductive biases about the domain-specific assumptions. The model is based on the iterative attention mechanism and has shown promising performance on image, video, audio and point cloud classification tasks. An improved version of Perceiver, named Perceiver IO [675], is then proposed to unify both inputs and outputs of various data and tasks. The model is tested on various tasks with structured inputs and outputs including multi-task language understanding, optical flow prediction, video+audio autoencoding, etc. Although these models can process different data and tasks by design, the model itself can only perform a single specific task. Recently, a few efforts are made to learn a single model for a range of data and tasks. GPV [676] proposes a general purpose vision system that takes an image and a natural language task description as the inputs and outputs bounding boxes and text for various vision tasks including object detection, visual question answering (VQA) and image captioning. Li et al. [677] learn a single unified model for both images and texts, which exhibits superior performance on both tasks. data2vec [678] presents a general self-supervised learning framework for speech, vision and language. While these models avoid some of modality dependent architectural choices and unify some of the modality during training, existing models still cannot unify all data forms and commonly considered downstream application tasks (e.g., recognition, detection, segmentation, and distance prediction tasks from both images and scanned point clouds for autonomous vehicles). Developing a total modality-agnostic and task-agnostic model and learning framework is still an open and interesting future direction.

### 7.4.2 Efficient Models for Edge Devices

Training large-scale vision models usually requires large amount of data and considerable computation power. In many real-world applications, it is impossible to directly use large vision models. Therefore, developing light-weight counterparts of large vision models for edge devices and resource-constrained environments becomes an emerging topic that can largely expand the applications of big vision models. Some recent work [679,680,622,623] has explored efficient and hardware friendly Transformers architectures for efficient inference. However, distilling and transferring the knowledge learned by large-scale vision models to lightweight models that are easy to deploy is still an open problem.

### 7.4.3 Dynamic Visual Models

Dynamic visual models are a collection of models that can change the architectures or parameters according to different inputs during inference. Since dynamic visual models usually have better efficiency, generality and compatibility, then have attracted researchers' attention in recent years. Dynamic visual models can be roughly categorized as three types [681]: sample-wise, spatial-wise and temporal-wise. Sample-wise dynamic networks [682,683] adjust the architectures (depth, width, etc.) and parameters to input sample. Spatial-wise dynamic networks [684,685] perform adaptive inference on various spatial locations of images, e.g., the computation for different regions are different. Temporal-wise dynamic networks [686,687] process along the temporal axis to select most informative frames for prediction. Constructing dynamic visual models can make the big model more efficient and generalize well to various tasks. However, a serious problem is that the efficiency of current dynamic visual models may not match the theoretical one. Some dynamic visual models introduce operations that are hardware-unfriendly thus can hardly be used in real applications. Therefore, how to design dynamic visual models that can achieve acceleration in real application becomes an interesting problem.

### 7.4.4 Interpretability

Understanding the decisions of vision models can help us to diagnose the wrong behaviors and avoid unwanted biases of the models. Therefore, the interpretability becomes an important research topic. Although there are plenty of works on the interpretability of CNNs [688,689,690], interpreting vision Transformers is still an open problem. Since ViTs have

been proved to have better generalization and robustness [691], it becomes more interesting to investigate why they behave different from CNNs. The main difficulty of interpreting vision Transformers lies in the complex token mixing operations in each block. Some recent related works [692] adopt LRP-based relevance score to interpret Transformer. However, these methods are based on some simplistic assumptions and can only provide visualizations rather than improve the performance of the Transformers. Exploiting the interpretability of vision Transformers can provide us a more clear understanding for better architecture design and can also mitigate some societal issues brought by big models since their behaviors will become more predictable.

## 8 Big Multi-modal Model

*Authors: Shuai Zhao<sup>\*</sup>, Yizhao Gao<sup>\*</sup>, Liang Zhang<sup>\*</sup>, Ming Ding<sup>\*</sup>, Nanyi Fei, Anwen Hu, Zhiwu Lu<sup>✉</sup>, Qin Jin<sup>✉</sup>, Ruihua Song, Ji-Rong Wen*

Human brains are complex systems that can process information from multiple sensory modalities. That is, they are capable of simultaneously handling language, image, video and other modal information, which allows us to accurately and efficiently complete perception, understanding, and decision-making tasks. To mimic these core cognitive abilities of us humans, it is necessary and also promising for AI models to train on large-scale multi-modal data. The key challenge of training a big multi-modal model is to learn the correlations and the complementarity of multiple modalities due to the heterogeneity of multi-modal data. The recent trend of utilizing large-scale multi-modal data crawled from the Internet as the pre-training data collection [31, 693, 34, 694] has also raised another challenge of how to make full use of such huge data, because it is impossible for careful human annotation and there inevitably exists a certain amount of data noise. The goal of big multi-modal models is to align data from different modalities and acquire the ability to transfer their learned knowledge to various downstream tasks, finally ultimately approach strong AI. In general, current research on multi-modal models mainly focuses on video, image, speech and language modal, as shown in Fig. 22. Since the Vision-Language Pre-training (VLP) model takes a large proportion in current research, our next introduction will mainly focus on this part. We believe that the exploration of big multi-modal BMs has just started, and they have the potential to make AI research to the next level.

To give readers a better understanding of VLP models, in this section, we will thoroughly summarize the existing literature.

- In Section 8.1, we will describe how VLP model process and represent the different multi-modal information, such as images and text.
- In Section 8.2, we will introduce the popular architecture of VLP models, including Single-stream and Dual-stream.
- In Section 8.3, we will presents diverse pre-training tasks that the VLP models are always applied to.
- In Section 8.4 we will introduce several downstream tasks including generation task and understanding task.
- Finally, in Section 8.5 we will discuss several potential research directions that are worth studying in the near future.

### 8.1 Feature Representation

This section describes how VLP models preprocess and represent an image, and text to obtain counterpart features.

#### 8.1.1 Image Representation

Text information usually consists of multiple sentences of different lengths and has the maximum length of 512 words. Images are quite different, as the input image size used for classification network is  $224 * 224$  ( $50,176pixels$ ), which is relative small compare to some other computer vision such as object detection and semantic segmentation etc. Therefore, how to represent continuous vision contents in a discontinuous way is an important work. As shown in Fig. 23, the commonly used image discretization methods can be concluded as four categories: Pixel-based, OD-based (object detection), Patch-based and VQ-based (Vector Quantified).

**OD-based** image representation methods are commonly used, especially when image contains multiple objects. Most of VLP models adopt object detector to extract regions before embedding each region features. And the most commonly used object detection model is Faster R-CNN with bottom-up attention [427]. It mainly proposes a top-down and bottom-up attention method, which is firstly applied to the related problems of Visual Question Answering

---

Shuai Zhao, Yizhao Gao, Liang Zhang and Ning Ding contribute equally.

Zhiwu Lu (luzhiwu@ruc.edu.cn) and Qin Jin (qjin@ruc.edu.cn) are the corresponding authors of Section 8.

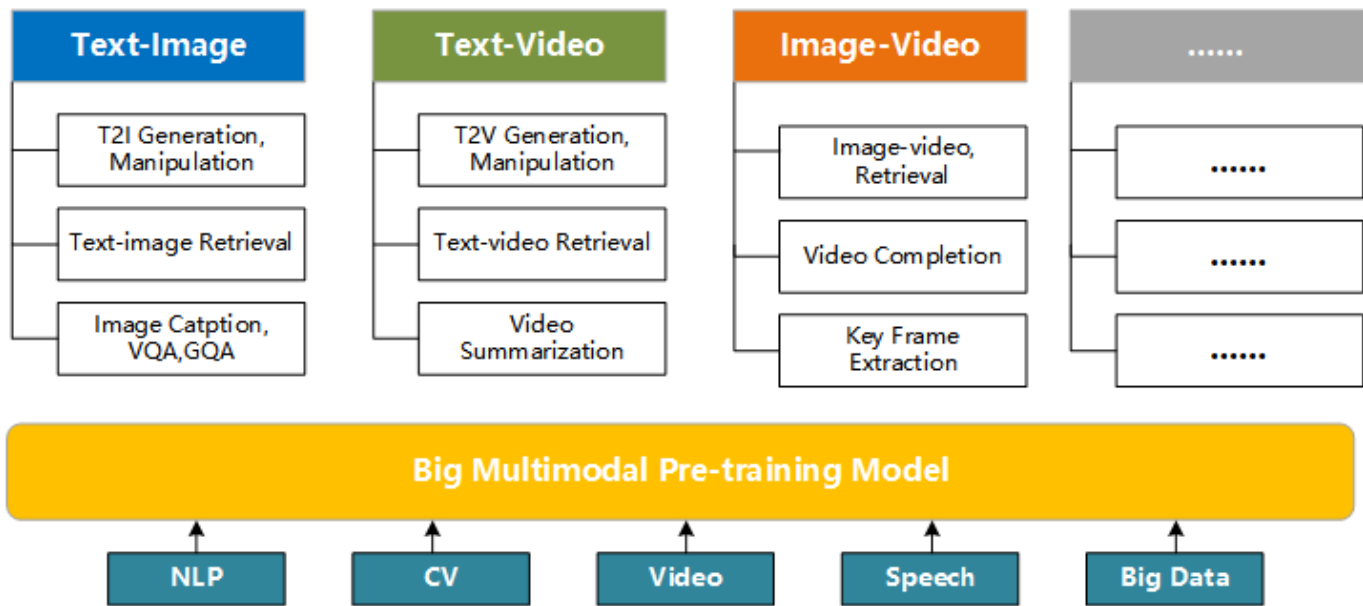

Fig. 22. A typical architecture of big multi-modal pre-training models and its downstream tasks.

(VQA) systems. By using Faster R-CNN, the multi-modal big models first achieve the region-based representation  $V = [v_1, v_2, v_3, \dots, v_k]$  of an image with  $k$  selected regions. Each region feature  $v_i$  is a 2048-d feature with its bounding box. The bounding box is defined by the coordinates of the bottom-left and top-right corners of the region. Then model uses bounding boxes to construct 5-d vectors, and the vector is embedded into a high-dimensional representation named visual geometry embedding. Region-based methods have brought impressive performance on many downstream tasks, such as VQA, IR, TR, etc. But unfortunately it is always time consuming and easily affected by the performance of object detectors.

**Pixel-based** representation is inspired by the NLP models that encode sentence word by word. Some VLP models use the CNN architecture to embedding an image as a whole. Images are processed by VGG or Resnet backbone with the FC and classification layers cut to reduce the image resolution. The OD-based representation are designed for specific vision tasks, which can cause a gap towards language understanding. Because some important visual information is missing, such as the shape, spatial relationship and coincidence of objects in the figure. In addition, the semantic representation capability is limited to the semantic categories contained in the model used by the task, which means semantic information cannot be obtained for objects that are out of the domain. In contrast, the pixel-based representation dose not suffer from that problem.

**Patch-based** image representation is a kind of newly developed approach. Recently, ViT [28] first splits the image into multiple non-overlapping patches, and then use linear projections to convert the flattened patches to visual tokens. Inspired by this work, some VLP models are reshaped into patches to representation image features. Specifically, the input image  $x \in \mathbb{R}^{H \times W \times C}$  was split into a sequence of flatten 2D patches  $x \in \mathbb{R}^{N \times (P^2 C) \times H \times W \times C}$  where (H, W) is the resolution of the original image, C is the number of channels, (P, P) is the size of each image patch, and N is the resulting number of patches. ALBEF [695] and SimVLM [696] feed patches to an ViT encoder to extract image features, which lead the way to a full transformer VLP model.

**VQ-based** method is another category of image representation approach. For text-to-image generation tasks, we expect the network to draw an image with a small amount of text guidance. Meanwhile, in order to ensure the diversity and reality of the generated images, some studies try to adopt a limited-dimensional query vocabulary called codebook based on VAE. Some recent research work [33, 32, 202] has shown super ability of semantically controlled image generation, where utilize the VQ-based representation and text embedding as GPT-2 inputs. And the generative model can even understand some basic vision concepts such as object shape, positional relationship, color, etc.

### 8.1.2 Text Feature Extraction

Most existing studies on VL-BMs utilize BERT as the text encoder to encode text. A text is first concatenated with a  $[CLS]$  token, denoted as  $W = [w_1, w_2, \dots, w_t]$ . Each token  $w_j$  will be mapped into a word embedding  $Ew(w_j)$ . Besides, to indicate the index of the token in the sequence, each token corresponds to a positional embedding  $Ep(w_j)$  and a segment embedding  $Es(w_j)$ . By feeding the summation of word embeddings, positional embeddings,



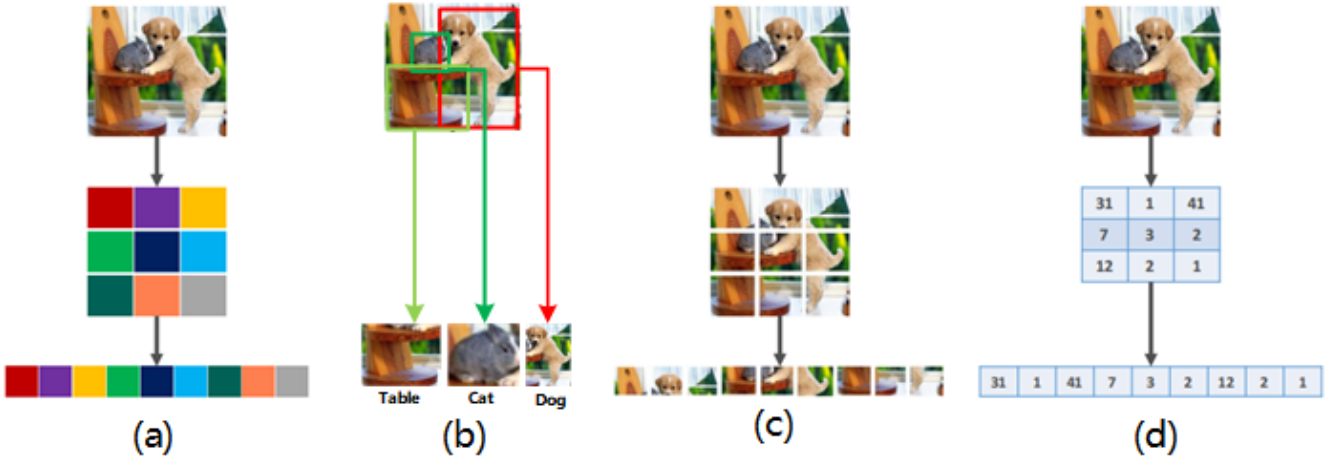

**Fig. 23.** Four typical image representation approaches for VLP models. (a) Pixel-based, (b) Object detection (OD-based), (c) Patch-based (ViT), (d) Vector Quantised (VQ-based).

and segment embeddings into BERT, we can obtain the final input text representation of  $W$ , denoted as  $\hat{E}(W) = [\hat{E}_w([CLS]), \hat{E}_w(w_1), \dots, \hat{E}_w(w_t)]$

## 8.2 Model Architecture

According to the different aggregation methods between each modality, we mainly divided approaches of VLP models into two categories: fusion encoder and dual encoder. The fusion encoder method utilizes a deep network to interact with images and text features. These models always achieve better performance in complicated VL understanding tasks, such as VQA (Visual Question Answering), Visual Commonsense Reasoning (VCR), IC(image captioning), etc. However, the inference process of fusion encoder method is slow due to the continuous modality fusion. In contrast, the dual encoder applies two separate encoders to encode vision and text information and uses cosine similarity or a linear projection layer to measure the distance between them. Many studies have proved dual encoder methods are effective in VL retrieval and some classification tasks, but fail to handle complex reasoning tasks, such as NLVR and visual reasoning.

### 8.2.1 Fusion Encoder

Generally, we expect the VLP models can learn the connections between images and text and reduce the semantic gap. For example, the model was able to correlate the appearance of a dog in an image with the word of 'dog' in the text. Therefore, in order to achieve this goal, the fusion encoders need to be carefully designed. According to the fusion process of different modalities, it can be mainly classified into two categories: single-stream and two-stream.

**Single-stream** The single-stream methods directly concatenate the image features and language embedding together, then utilize a single transformer network to model. It is obvious that the single-stream is more efficient as parameters are shared between embedding end-to-end. Besides, some studies [697,698,699,700] show that fusing cross-modal information early and freely can achieve better performance.

**Dual-stream** The dual-stream architecture utilizes two single-modal transformers to process visual feature and language embedding respectively, and then fusing them through a series of self-attention-based or cross-attention-based interactions. This approach allows for variable network depth for each modality and enables cross-modal connections at different depths.

### 8.2.2 Dual Encoder

OpenAI CLIP [31], as the representative work of dual encoder model, has shown surprisingly good performance on some zero-shot downstream tasks. It uses separated transformer embedding for image and language information. Unlike fusion encoder models focused on learning visual concept from scratch via natural language supervision and dense interaction between two domains, CLIP only adopts a single dot product in a learned joint embedding space to calculate the similarity. Dual encoder models [33,202,695] are efficient in retrieval tasks. With the help of large-scale



pretraining data, zero-shot and few-shot transfer of dual encoder models show huge potential to various classification tasks.

### 8.3 Pre-training Tasks

After the input images and texts are encoded as vectors and fully interacted, the next step is to design pre-training tasks for VLP models. In this section, we introduce how to pre-train VLP models by using different pre-training objectives, which have a great impact on what VLP models can learn from the data.

#### 8.3.1 Masked Language Modeling

Masked language modeling (MLM), which is widely known as the BERT-based modeling, is adapted as a novel pre-training task. The concept was first proposed by Taylor [701] in his literature in 1953. In addition to BERT, where masked words are predicted from the non-masked words in the language modality, LXMERT proposes cross-modality model architecture that could predict masked words from the visual modality as well so as to resolve ambiguity. For example, it is hard to determine the masked word “carrot” from its language “Who is eating the carrot?”, but the word choice is clear if the visual information is available. Besides, ViLT [702] uses the Whole Word Masking strategy, which prevents the model from predicting tokens solely by words co-occurrence; InterBERT [703] masks several continuous segments of text and improves the performance further. Formally, the objective can be defined as:

$$\mathcal{L}_{MLM}(\theta) = -\mathbb{E}_{(\mathbf{w}, \mathbf{v}) \sim D} f_{\theta}(\mathbf{w}_{\mathbf{m}} | \mathbf{w}_{\setminus \mathbf{m}}, \mathbf{v}) \quad (19)$$

Where  $\mathbf{v} = (v_1, v_2, \dots, v_k)$  denote the image regions,  $\mathbf{w} = (w_1, w_2, \dots, w_T)$  is the input text, and  $w_{\setminus m}$  means the mask indices.  $\theta$  is the trainable parameters. MLM randomly masks words with a probability of 15%, and replaces the masked ones with special token [MASK]. Then the model is asked to predict these masked words.

#### 8.3.2 Masked Vision Modeling

Inspired by MLM in the pre-training process, VLP models also sample vision parts (regions, objects or patches) and usually mask them with a probability of 15%. The model is trained to reconstruct the mask vision features  $\mathbf{v}_{\mathbf{m}}$  given the remaining vision features  $\mathbf{v}_{\setminus m}$  and all the words  $\mathbf{w}$ . The vision features of the masked region are set to zeros. Unlike textual tokens that are represented as discrete labels, visual features are high-dimensional and continuous, thus cannot be supervised via class likelihood. The object function is:

$$\mathcal{L}_{MVM}(\theta) = -\mathbb{E}_{(\mathbf{w}, \mathbf{v}) \sim D} f_{\theta}(\mathbf{v}_{\mathbf{m}} | \mathbf{v}_{\setminus \mathbf{m}}, \mathbf{w}) \quad (20)$$

**(1) Masked Vision Features Regression(MFR)** learns to regress the model output of masked features of each masked region  $\mathbf{v}_{\mathbf{m}}^{(i)}$  to its original visual features. VLP models always convert the model output from the transformers into a vector of the same dimension as the original visual feature by an FC layer or linear projection. And then apply the L2 regression between the original visual features and the vector. When images are represented as a sequence of region features by Faster-RCNN, simple masking strategies like random masking can give satisfying performance. However, random masking will not be so effective when images are converted into grid features or patch features, because the model will directly duplicate neighbor features as the predicted features. Visual parsing [704] uses patch features to represent an image and assumes that visual tokens of high attention weights have similar semantics. It first randomly masks a visual token as a pivot token, and continues to mask  $k$  tokens with top- $k$  attention weights. SOHO [705] pre-trains a vision Dictionary (VD) and masks all the features sharing the same visual index to avoid information leakage.

**(2) Masked Vision Feature Classification (MFC)** learns to predict the object semantic class for each masked visual part. The model first feeds the transformer output of the masked region  $\mathbf{v}_{\mathbf{m}}^i$  into an FC layer to predict the score of the object class, which further goes through a softmax function to be transformed into a prediction normalized distribution. Note that there is no ground-truth label, as the object categories are not provided. Generally, there are two ways to solve this problem. First, using the object detection output label from the detectors, the VLP models can take the category with the highest confidence score as the ground-truth label and then apply cross-entropy loss to minimize the gap between them. Since the most likely object class from the object detection model may not be true and highly relies on the quality of the detectors, thus there are some variants about the MFC task. ViLBERT [702] and UNITER [698] try to adopt soft label as supervision signal named MFC-kl. Briefly, the MFC-kl aims to minimize the KL divergence between the detector and prediction distributions in a soft way. SOHO [705] first maps the CNN-based grid features to visual tokens, and then predicts the masked visual tokens based on their surrounding tokens.

**Table 10.** The summary of mainstream VLP models. IE-TE: image embedding and text embedding. LP in IE-LE column: linear projection.

Model	IE-LE	Multi-modal Fusion	Pretraining Tasks	Pretraining Datasets	Downstream Tasks
VisualBERT	ODs - BERT	Single-stream	MLM+VLM	COCO	GRE+NLVR+VCR+VQA
ViLBERT [2019]	ODs - BERT	Dual-stream	MLM+VLM+MVM	COCO+VG	VLN+NLVR+VE+VQA
LXMERT [2019]	ODs - Transformer	Dual-stream	MLM+VLM+MVM+VQA	COCO+VG+VQA+GQA+VGQA	GQA+NLVR+VQA
VL-BERT [2019]	ODs - BERT	Single-stream	MLM+MVM	CC3M	GRE+VCR+VQA
Unicoder-VL [2020]	ODs - BERT	Single-stream	MLM+VLM+MVM	CC3M+SBU	VLN+VCR
VLP [2020]	ODs - BERT	Dual-stream	MLM+LM	CC3M	VC+VQA
UNITER [2020]	ODs - BERT	Single-stream	MLM+VLM+MVM	COCO+VG+SBU+CC3M	GRE+VLN+NLVR+VCR+VE+VQA
ImageBERT [2020]	ODs - BERT	Single-stream	MLM+VLM+MVM	LAIT+CC3M+SBU	VLN
PREVALENT [2020]	Pixel - BERT	Single-stream	MLM+MVM	Matterport3D	VLN
XGPT [2020]	Pixel - BERT	Dual-stream	MLM+IDA+VC+TIFG	CC3M	VC+VLR
InterBERT [2020]	ODs - BERT	Single-stream	MLM+VLM+MVM	COCO+CC3M+SBU	VLN+VCR
PixelBERT [2020]	Pixel - BERT	Single-stream	MLM+VLM	COCO+SBU+CC3M+FLKR+VQA+GQA+VGQA	GQA+VC+VLN+NLVR+NoCaps+VQA
Unified VLP[2020]	ODs - UniLM	Single-stream	MLM+VLM	CC3M	VC+VQA
UNIMO [2020]	ODs - BERT, RoBERTa	Single-stream	MLM+MRC+MRFR+VLM	COCO+VG+SBU+CC3M	GRE+VLN+NLVR+VCR+VE+VQA
OSCAR [2020c]	ODs - BERT	Single-stream	MLM+VLM	COCO+VG+SBU+CC3M	GRE+VLN+NLVR+VCR+VE+VQA
FashionBERT [2020]	ViT - BERT	Single-stream	MLM+VLM+MVM	FashionGen	ITR
ERNIE-ViL [2020]	ODs - BERT	Single-stream	MLM+MVM	CC3M+SBU	GRE+VLN+VCR+VQA
RVL-BERT [2021]	ODs - BERT	Single-stream	MLM+VLM+MVM	CC3M	VC+VQA
VinVL [2021]	ODs - BERT	Single-stream	MLM+VLM	COCO+CC3M+SBU+FLKR+VQA+GQA+VGQA	GQA+VC+VLN+NLVR+NoCaps+VQA
VL-T5 [2021]	ODs - T5, BART	Single-stream	MLM+VLM+VQA+GRE+VC	COCO+VG+VQA+GQA+VGQA	GQA+GRE+VC+MMT+NLVR+VCR+VQA
VLT [2021]	LP - BERT	Single-stream	MLM+VLM	COCO+VG+SBU+CC3M	VLN+NLVR+VQA
ALIGN [2021]	Patch - Transformer	Dual Encoder	CMCL	AltText	VLN
Kaleido-BERT [2021]	Pixel - BERT	Single-stream	MLM+VLM+AKPM	FashionGen	CR+VC+VLR
MDETR [2021]	Patch - BERT	Single-stream	MLM+CMCL	COCO+VG+FLKR+GQA	GQA+VQA
SOHO [2021]	VD - BERT	Single-stream	MLM+VLM+MVM	COCO+VG	VLN+NLVR+VE+VQA
EZE-VLP [2021]	Pixel - BERT	Single-stream	MLM+VLM	COCO+VG	VC+VLN+NLVR+VQA
Visual Parsing [2021]	Patch - BERT	Single-stream	MLM+VLM+MVM	COCO+VG	VLN+VCR+VE+VQA
CLIP-ViL [2021]	Pixel - BERT	Single-stream	MLM+VLM+VQA	COCO+VG+VQA+GQA+VGQA	VE+VLN+VQA
ALBEF [2021]	Patch - Transformer	Dual-stream	MLM+VLM+CMCL	COCO+VG+CC3M+SBU	VLN+NLVR+VQA
SimVLM [2021b]	Pixel - BERT	Single-stream	seq2seq LM	AltText	VC+NLVR+VE+VQA
WenLan [2021]	ODs - BERT	Dual-stream	MLM+VLM	-	ITR
MURAL [2021]	Pixel - Transformer	Dual-stream	VLM	CC12M+AltText	VC+VLR
VLMO [2021a]	Patch - BERT	Single-stream	MLM+CMCL+VLM	COCO+VG+CC3M+SBU	VQA+NLVR+VLR
METER [2021]	Patch - Transformer	Dual-stream	MLM+VLM	COCO+VG+CC3M+SBU	VLN+NLVR+VE+VQA
CLIP [2021]	Patch - GPT2	Dual Encoder	CMCL	SC	OCR +AC etc.
FLAVA [2021]	Patch - Transformer	Dual Encoder	MMM+ITM+CMCL	COCO+VG+SBU+LN+WIT+CC12M+RC+YFCC	OCR +AC etc.
X-LXMERT[2020]	ODs - WordPiece	Dual-stream	MLM+ITM+MRC+MRFR+VQA	COCO+VG+VQA+GQA+VGQA	T2I+GQA+NLVR+VQA
DALL-E	dVAE - GPT-3	-	-	LAION-400M	T2I-IC+ITR
Cogview [2021]	VAE - GPT-2	-	-	WudaoCorpora	T2I-IC+ITR
M6 [2021]	dVAE - GPT-2	-	-	M6-Corpus	T2I-IC+ITR

### 8.3.3 Vision Language Matching

Vision Language Matching (VLM) is similar to the Next Sentence Prediction (NSP) task in NLP, which requires the model to predict whether the image and text are matched. MLM and MVM help VLP models learn the fine-grained correlation between vision and texts, while the VTM task empowers the model ability to align them at a coarse-grained level. In single-stream models [698, 700, 703], VLM uses the representation of the special token  $[CLS]$  as the fused representation of both modalities. In the dual-stream models [702, 706, 707], they always concatenate the visual representation  $[CLS_v]$  from the vision transformer and the textual outputs  $[CLS_T]$  as the fused representation of both modalities. Then feed it to an FC layer and a sigmoid function to predict a score between 0 and 1, where 0 indicates the vision and language are mismatched and 1 indicates the vision and language are matched. The object function is:

$$\mathcal{L}_{VLM}(\theta) = -\mathbb{E}_{(\mathbf{w}, \mathbf{v}) \sim D} [y \log s_{\theta}(\mathbf{w}, \mathbf{v}) + (1 - y) \log(1 - s_{\theta}(\mathbf{w}, \mathbf{v}))] \quad (21)$$

Where  $s_{\theta}(\mathbf{w}, \mathbf{v})$  denote the output score. The key of this task is how to represent an image and text pair in a single vector. Except for the connection method above, ViLBERT uses the last hidden states of  $[IMG]$  and  $[CLS]$  tokens to represent vision and language respectively, and the fused representation is computed by element-wise product between them.

### 8.3.4 Cross-Modal Contrastive Learning

Cross-Modal Contrastive Learning (CMCL) given two random variables  $w_i$  and  $v_i$ , often from different domains, CMCL aims to find useful representations of  $w_i$  and  $v_i$  by learning a function that measures the dependence of the two. The image and text contrastive loss can be formulated as:

$$\mathcal{L}(\theta)_{I2T} = -\frac{1}{n} \sum_N \log \frac{\exp(x_i^T y_i / \theta)}{\sum_{j=1}^N \exp(x_i^T y_j / \theta)} \quad (22)$$

where  $x_i$  and  $y_i$  represent the normalized image embedding in the  $i$ -th pair and normalized text embedding in the  $j$ -th pair, respectively,  $\theta$  is a learnable temperature parameter. It is equivalent to learn a score function  $s_{\theta}(x_i, y_i) = \frac{\exp(x_i^T y_i)}{\sum_{j=1}^N \exp(x_i^T y_j)}$ , such that parallel image and text pairs have higher similarity scores. It is worth noting that the contrastive loss in CMCL is not unidirectional, and the text-to-image contrastive loss is formulated symmetrically.

## 8.4 Downstream Tasks

To fully validate the performance of VLP models, a diverse of downstream tasks are available. In this section, we introduce several common vision-language integration tasks and divide them into five categories: understanding task and generation task.

### 8.4.1 Understanding Tasks

**Visual Question Answering (VQA)** is a common multi-modal evaluation task. It always contains open-ended questions about images. Giving a visual input, VQA represents the task of correctly providing an answer to the question. The answer needs the VLP model to have a comprehensive understanding of the image and question. Most researchers consider VQA as a classification task and require the model to select a correct answer from an answer pool. Specifically, the VLM models usually map the final cross-modal representation to the distribution of answer labels. However, VLP models with a dual-encoder architecture are not so effective for VQA tasks because the interaction between the two modalities may be too shallow to do cross-modal reasoning. There are also some works modeling VQA as a generation task, which can generalize better to real-world open-ended scenarios. The currently used VQA datasets include DAQUAR [708], Visual Genome [709], MSCOCO-QA [710], VQA [711], etc. And in 2017, the VQA v1.0 was updated to VQA v2.0, which expanded the original 614k to 1.1M questions, including real people providing open and yes-no questions and various candidate answers.

**Grounding Question Answering (GQA)** is an upgraded version of VQA and aims to advance research on the visual reasoning of natural scenes. The advantage of this structured representation is that the distribution of answers can be more uniform, and we can analyze the model’s performance from more dimensions. GQA dataset was proposed in 2019 [712], it consists of 22M questions, including various images from MSCOCO and Flickr. Each image is associated with a scene graph of the image’s objects, attributes, and relations. While each question is associated with a structured representation of its semantics, a functional program that specifies the reasoning steps to be taken to answer it. In addition, GQA’s evaluation is more diverse than VQA’s, including Consistency, Validity, Plausibility, Distribution, Grounding, and Accuracy. However, multi-modal models usually use a single Accuracy as an evaluation indicator.

**Natural Language for Visual Reasoning (NLVR)** similar to VQA, NLVR takes vision and textual as input and predicts whether the statement is true about the image. But the input of vision is an image pair, and mostly VLM models regard it as a binary classification task as did in the VQA task. The NLVR dataset initiated by Facebook ParLAI Research Award [713] contains 107,292 examples of human-written sentences grounded in pairs of photographs.

**Visual Commonsense Reasoning (VCR)** is regarded as one of the most authoritative rankings in the field of multi-modal understanding [712]. The difference between VCR and VQA is that VCR’s questions pay more attention to visual common sense. VCR exists in the The VCR task can be decomposed into two multi-choice sub-tasks: question answering ( $Q \rightarrow A$ ) and answer justification ( $QA \rightarrow R$ ). Specifically, for a question, there are several alternative answers. The model must choose an answer from several answers ( $(Q \rightarrow A)$ ) and then select the reason for choosing this answer from several alternative reasons ( $QA \rightarrow R$ ), which requires the VLM model to recognize the attributes and relationships of the characters in the figure and further infer the intentions of the characters on this basis.

**Image-Text Retrieval (IR&TR)** is a classic task in the cross-modal field. There are two sub-tasks: image retrieval and text retrieval, depending on which modality is used as the retrieved target. Early VLP models that utilize a fusion-encoder architecture obtain a fused vector representation which is later projected to a similarity score, While Dual-encoder architectures such as CLIP and ALBEF are more efficient for ITR, because they can pre-compute and store the embedding of images and texts before retrieval. MSCOCO and Flickr30K [714] are two regular data sets for multi-modal retrieval tasks. The Flickr30k dataset contains 31,000 images collected from Flickr and five reference sentences provided by human annotators. MSCOCO dataset contains 330,000 images, and five independent human-generated captions are provided for each image. Specifically, the VLP modal takes image and text features to predict the matching score, top  $k$  retrieval results will be treated as the modal evaluation index.

**Referring Expression (RE)** is an extension of the referring expression task in NLP. RE task asks the VLP models to locate the region in the image that corresponds to the given textual description. Most VLP models take the final representation of the extracted region proposals as input and learn a linear projection (FC layer) to predict a matching score. This task involves fine-grained cross-modal semantic alignment. Therefore, it is more important to examine the fineness of the semantic description of the joint representation. RE task mainly contains three referring expression datasets based on the MSCOCO dataset [715]: RefCOCO, RefCOCO+ and RefCOCOg.

### 8.4.2 Generation

Based on the source modal and target modal, the generation task can be divided into text-to-image generation (T2I) and image-to-text generation (IC).

**Text-to-Image Generation (T2I)** Generating a corresponding image from a descriptive text is a challenging and interesting task. Unlike other downstream tasks, the T2I task pays more attention to the quality of image generation, that is, the painting ability of VLM models. Early, with the emergence of generative adversarial networks (GANs), researchers studied to generate images with a random number or restrictive conditions such as painting style, face expression, hair color, etc. But all these representations are discrete variables. The VLP models are a good fusion of text and visual information, some literature attempts to use text to guide image generation and made some achievements. X-LXMERT [716] refines the pre-training process by discretizing visual representations and designing strategies that enable the model to predict visual clusters. ERNIE-ViLG [717] formulates the text-to-image generation task as an autoregressive generative task and achieves new state-of-the-art result on MS-COCO.

Besides, there is also some transformer and GANs (or VAE) fusion work. DALL-E first proposed an ingenious fusion method of image and text. During the pre-training process, images are discretized into vectors through dVAE, and the text is embedded through BPE architecture. Then the model trains image-text feature pairs with transformers by autoregressive method. In the inferencing process, the input is a randomly initialized image and a descriptive text. According to the fusion representation that is produced by the transformer layer, we can input it in the dVAE decoder and generate the corresponding image. Finally, all generation images are sorted by the CLIP model. Similarly, Cogview [33] and M6 [202] use proposes to employ GPT-2 and VAE to Chinese language guide image generator. In addition, some diverse applications based on CLIP and VQGAN are all the rage on the web.

**Image Captioning (IC)** Different from the understanding tasks, IC can be regarded as a special type of conditional text generation, where the condition includes not only texts but also images. The VLP modal needs to generate a natural language description of a given image. Generally, a decoder is needed for the generation process. XGPT [718] and VL-T5 [719] take image features as input and use a decoder to generate the corresponding captions autoregressively. IC task experiments always took on MSCOCO captioning dataset. It should be noted that, unlike the previous evaluation indicators, BLEU [720], METEOR [721], CIDEr-D [722], SPICE [723] are often used as metrics of the text-generation quality.

**Novel Object Captioning (NoCaps)** extends the image-to-text task. NoCaps points out that image captioning tasks need amounts of paired image-text training data, while unlikely to be obtained in some specific tasks [724]. So, it aims to evaluate whether the model can accurately describe the newly appeared categories of objects in the test image without corresponding training data. In NoCaps, the associated training data consists of COCO image-caption pairs, Open Images image-level labels and object bounding boxes. Since Open Images contains many more classes than COCO, nearly 400 object classes seen in test images have no or very few associated training captions. In terms of metrics, to provide a more fine-grained analysis, the evaluation of NoCaps is divided into three subsets: in-domain, near-domain, and out-of-domain.

## 8.5 Challenges and Future Directions

Existing contributions in the literature of big multi-modal BMs have laid a solid foundation for future development. Although it is a promising research field, there are still many problems waiting to be solved and many sub-areas waiting to be explored.

### 8.5.1 Image-Text Occupy Large Proportion

Most recently, a large number of researchers have been paying attention to VLP models, while relatively fewer efforts have been focused on pre-training with other modalities (e.g., speech-text, speech-video) or even with various modalities instead of just two. Exploiting data from more modalities is also very meaningful, and it may make exciting and major discoveries, eventually leading AI models more similar to human brains.

In the field of multi-modal BMs itself, big models based on image-text data have drawn more attention than those concerning video-text data, and the exploitation for the former is much more advanced at present. Researchers [725] have found that directly applying image-text BMs for video-to-text retrieval task is even sometimes better than models pre-trained on the extremely large (i.e., 100 million) video-text dataset HowTo100M [726]. One possible reason is that some video-text benchmarks for text-to-video retrieval evaluations are not actually suited for videos. For example, the ground-truth captions for each video are mostly describing scenes during a very short period of time or even still scenes rather than describing what has happened throughout the whole video. That is, the time dimension of videos is not properly embodied by these captions, and thus, big image-text BMs can perform quite well on video-text benchmarks where the chronological information of videos is less needed. Therefore, to help develop BMs based on video-text pairs, it is necessary to construct high-quality video-text benchmarks which can really reflect the characters of video data. In addition, since videos have an extra time dimension than images with only spatial dimensions, it is also important to design algorithms to effectively model the time series information while learning cross-modal correlations at the same time.

### 8.5.2 Unified Model Architecture

Although VLP models have achieved great successes, there are still problems that could be further researched. One major issue is the conflict between single-stream-based and two-stream-based models. Concretely, models based on the single-stream network architecture typically adopt cross-modal fusion modules (e.g., Transformer encoders [25]), which take image-text pairs as input and output pair similarity scores. The biggest advantage of single-stream models is that they can achieve superior performance, especially on tasks requiring deep image understanding abilities (e.g., visual question answering and visual commonsense reasoning) because the cross-modal fusion modules allow closer interactions between image regions/objects and text words. However, the disadvantage of single-stream models is also obvious. That is, during the inference of cross-modal retrieval tasks, for each query, they have to pair all the candidates and compute all pair similarities, resulting in an  $O(N^2)$  time complexity. This is unbearable for real-world applications as the number of candidates is often huge. On the other hand, two-stream models utilize separate image and text encoders respectively to extract image and text feature embeddings, and then align the paired embeddings, typically adopting cross-modal contrastive learning algorithms. In this way, two-stream models enjoy a real-time inference speed for retrieval tasks, but compromise on performance due to the lack of closer interactions between the two modalities.

There are two main approaches to balance the effectiveness and efficiency: (1) for single-stream models, a two-stream architecture could be placed before the cross-modal fusion module to alleviate the huge retrieval latency while keeping the high-performance advantage as much as possible; (2) for two-stream ones, more learning objectives modeling finer/closer modality correlations could be considered to improve their performance while maintaining the advantage of super efficiency.

### 8.5.3 Security

For the whole society, big multi-modal BMs might bring potential risks and challenges. For example, when the pre-training data become larger, it is likely that big models might be prejudiced and have stereotypes about some topics, which should be avoided as much as possible before pre-training and also be handled when big models are applied to downstream tasks. Moreover, when big models have greater abilities, people with bad intentions might misuse them (e.g., manipulating or generating improper content), which would be harmful to our society. Overall, as researchers, we should all be aware of these risks and do the best we can to avoid them.

### 8.5.4 Incorporate more Multi-modal

As the works mentioned above, remarkable progress has been made for learning cross-lingual cross-modal representations. But there are still some topics that have not been fully studied. As shown in Table 10, the majority of existing multilingual multi-modal pre-training focus on understanding tasks such as retrieval and question answering. How to generate multilingual sentences is less explored. Secondly, although the existing models such as MURAL [727] can support hundreds of languages, it is still only less than 2% of all human languages. Some works such as UC2 [728] rely on translation augmentation of the English corpora, which are not infeasible for low resource languages. So how to support low resource languages with very little training data is an important research topic. Additionally, we find that the existing works typically train the model from scratch with multilingual multi-modal corpora, which ignore the knowledge learned from the existing models pre-trained in English. Intuitively, the semantic alignments between English and other modalities could be transferred to other languages easily. Thus, how to generalize existing multi-modal pre-training into multilingual is a meaningful research topic.

## 9 Theory and Interpretability

*Authors* : Cong Fang\*, Yisen Wang\*, Mingsheng Long\*, Quanshi Zhang\*, Zenan Ling, Zhouchen Lin<sup>✉</sup>, Liwei Wang<sup>✉</sup>

Theory and interpretability are of great importance for both the design and the training of big models. In recent years, the research of big models has obtained great outcomes. However, most achievements are gained in an empirical pattern. The lack of solid theoretical understanding for big models still restricts the further studies. The study of theory and interpretability can provide evidence for what is needed for big models and how they can be further improved.

In this section, we review recent theory and interpretability research progress on big models with a discussion on challenges and later point out some promising research directions.

---

Cong Fang, Yisen Wang and Mingsheng Long contribute equally to the Theory part.

Quanshi Zhang (zqs1022@sjtu.edu.cn) contributes the Interpretability part.

Zhouchen Lin (zlin@pku.edu.cn) and Liwei Wang (wanglw@pku.edu.cn) are the corresponding authors of Section 9.

- Section 9.1 discusses the research of big-model-related mathematical theories. According to the nature of big models, the discussion are mainly divided into three parts, which are neural network theory, transfer learning theory and self-supervised learning theory.
- Then in Section 9.2, we will review some researches referring to the interpretability of big models, including inputs illustration, knowledge representation, representation capacity and knowledge integration.
- The Section 9.3 proposes some future study directions for the theory and interpretability of big models.

## 9.1 Basic Theory of Big Model

Big models have received great empirical successes in recent years. However, while many useful techniques have been discovered by practitioners, there has been a lack of solid theoretical understanding for big models and pre-training until recently. Mathematical theory always plays an important role in the development of engineering. A good theory can provide reasonable explanations for how things work, findings that are the fundamental advantages/obstacles, and guidance on how to further improve the performances. While much effort has been made to study big models theoretically, much-limited understanding is still obtained by our community currently. In the rest of this work, we review recent theoretical progress on big models with a discussion on challenges and later point out some promising research directions.

### 9.1.1 Neural Network Theory

In the current big models, neural networks, are the basic components to form a big model under a sophisticated architecture design. Clearly, understanding how neural networks work would serve as a pillar for the theoretical investigation of big models. However, a satisfactory analysis of neural networks has long been vacant even in the traditionally supervised learning setting for two-layer ones. Despite this fact, there have been remarkable theoretical developments in the analysis of overparameterized neural networks. In particular, the traditional wisdom was stuck in the difficulty that neural network was a highly non-convex model, which means first-order algorithms such as gradient descent (GD) or stochastic gradient descent (SGD) may converge to bad local stationary points, whereas, recent results demonstrate that the neural network systems behave more like convex systems under various settings.

Specifically, we discuss two interesting views for mathematically analyzing neural networks. For more pieces of literature, one can see [729]. The first view is the neural tangent kernel view [730, 731, 732, 733, 734, 735, 736, 737, 738, 739]. Under a specialized scaling and a sufficient number of hidden units, it was shown that the neural network parameters would be restricted in a tiny region around the initial value. The neural networks with parameters under this regime can be regarded as a linear model with the random feature. It induces a kernel referred to as a *neural tangent kernel* [730]. Since the system becomes linear, it is solvable, and polynomial convergence rates to a globally optimal solution can be obtained provably. The other research lines applied the mean-field analysis to study the overparameterized neural networks [740, 741, 742, 743, 744, 745]. The key idea is first to study infinitely wide neural networks that are represented by probability measures over the neural network parameters and then consider approximation using finite hidden neurons. Although the system is not convex for parameters in general, it is surprisingly convex with respect to these probability measures. The (noisy) Gradient Descent algorithm is proved to achieve the globally optimal solution under suitable conditions.

Despite this significant progress, we should point out that it still remains a long way to well understand the neural networks even for two-layer ones in theory. For example, the neural tangent kernel view can achieve polynomial complexity. However, only random features are explored. This is inconsistent with the common belief that neural networks learn discriminative target features. In comparison, mean-field can describe a whole learning process but lacks quantitative computational results under general conditions. Therefore we need a more powerful analysis tool even for two-layer neural networks that shows better feature learning processes with polynomial computational complexities.

### 9.1.2 Transfer Learning Theory

Transfer learning is motivated by the ability of human beings to learn with minimal or no supervision based on previously acquired knowledge [542]. In the statistical regime, transfer learning is defined as *learning under distribution shift* [746], removing the *i.i.d.* assumption of standard supervised learning that the training and test data have to be drawn from the identical probability distribution. Transfer learning has become the oil to energize big models, in that a big model is built on pretext tasks via pre-training and then transferred to downstream tasks via fine-tuning [21].

The core problem of transfer learning theory is to derive PAC-learning generalization bounds under the distribution shift. This has been extensively studied in the field of *domain adaptation*, a transfer learning scenario where the training and test domains share the same input and output spaces while only the shift is on between training distribution  $\mathcal{P}$

and test distribution  $\mathcal{Q}$  [747]. The distribution shift can be measured by proper discrepancy metrics  $\text{disc}(\mathcal{P}, \mathcal{Q})$ , with which we can bound the risk of the test domain  $\epsilon_{\mathcal{Q}}$  by the risk of the training domain  $\epsilon_{\mathcal{P}}$ . Ben-David *et al.* [747] establish the first VC-dimension generalization bound under distribution shift based on the  $\mathcal{H}\Delta\mathcal{H}$ -Divergence for binary classification problems. Mohri *et al.* [748] extend the previous theory to Rademacher Complexity generalization bounds for a general class of loss functions that satisfy the symmetry and subadditivity, which can further explain regression problems. These vanilla theories have later been extended in many perspectives. The main line of the works studies different definitions of distribution discrepancy such as Generalized Discrepancy [749], Wasserstein Distance [750], Rényi Divergence [751], and Integral Probability Metric (IPM) [752], which in turn explain different categories of adaptation algorithms. Further, Germain *et al.* [753] propose a PAC-Bayesian theory for domain adaptation with specialization to linear classifiers.

Despite the remarkable advances in domain adaptation theory that have an influential impact on domain adaptation algorithms, the grand limitation is that the gap between theory and algorithms is still intolerable. First, generalization bound for classification with scoring functions has not been formally studied in domain adaptation. As scoring functions with margin loss provide informative generalization bound in the standard classification, there is a solid motivation to develop a *margin theory* for domain adaptation. Second, the hypothesis-induced discrepancies [747, 748] require taking supremum over hypothesis space  $\mathcal{H}\Delta\mathcal{H}$ , while achieving a lower generalization bound requires minimizing these discrepancies adversarially. Computing the supremum requires ergodicity over  $\mathcal{H}\Delta\mathcal{H}$ , and the optimal hypotheses in this problem might differ significantly from the optimal classifier, which highly increases the difficulty of optimization. Towards these challenges, Zhang *et al.* [754] propose a margin theory for domain adaptation, which introduces the Disparity Discrepancy (DD) for regression problems and the Margin Disparity Discrepancy (MDD) for multinomial classification problems. The margin theory can be seamlessly transformed into an adversarial learning algorithm, successfully bridging the gap between theory and algorithm in domain adaptation.

The theory of transferring big models in the out-of-distribution setting is still an area in its infancy. First, the theoretical understanding of how pre-training improves the transferability of deep models remains unclear. For example, what kind of knowledge learned in pre-training is transferable to downstream tasks? What kind of pretext tasks endow higher transferability to a broader range of downstream tasks? Second, the generalization bounds to guarantee the fine-tuning performance is missing. In general transfer learning scenarios, pre-training and fine-tuning usually involve tasks of different output spaces, which goes far beyond the PAC-learning framework. We need a completely new mathematical framework to learn about the learnability across different data distributions and heterogeneous sample spaces.

### 9.1.3 Self-supervised Learning Theory

Self-Supervised Learning (SSL) emerges to be a promising paradigm for learning data representations without labeled data. Recently, it has achieved impressive results and gradually closed the gap between supervised and unsupervised learning, hopefully leading to a new era that resolves the hunger for labeled data in the deep learning field.

One promising SSL paradigm is contrastive learning. For an anchor sample  $x$ , we apply a random augmentation to it and learn to align the representations of  $x$  and its augmented view  $x^+$  (positive samples) while separating views generated from different samples  $x^-$  (negative samples). Formally, a popular choice of the contrastive objective is the InfoNCE loss [755],

$$\mathcal{L}_{\text{InfoNCE}}(f) = \mathbb{E}_{p(x, x^+)} \mathbb{E}_{\{p(x_i^-)\}} \left[ -\log \frac{\exp(f(x)^\top f(x^+))}{\sum_{i=1}^M \exp(f(x)^\top f(x_i^-))} \right], \quad (23)$$

where  $x^+$  denotes the positive sample, and  $\{x_i^-\}$  denotes  $K$  independently drawn (negative) samples. State-of-the-art contrastive learning has achieved over 80% top-1 accuracy on ImageNet [756], almost on the heel of supervised learning.

There has been a rising trend of very-large-scale BMs, led by the representative OpenAI work, GPT-3 [20], a universal language model with 175 billion parameters, as well as a few variants like Image-GPT [757], CLIP [31], and DALL-E [32] for image data. Taking GPT-3 for an example, it is trained on a mixture of massive unlabeled corpus (constituting nearly 500 billion tokens) in a self-supervised way, more specifically, with a language modeling task that learns to predict the next word. Big models like GPT-3 have demonstrated impressive capabilities on various benchmark tasks, including natural language understanding, story writing, dialogue generation, image generation, and zero-shot image classification.

However, despite its intriguing empirical success, a theoretical understanding of how self-supervised learning works in practice is still under-explored. It remains in mystery how they could learn class-separated features as required by downstream tasks through surrogates tasks. In particular, for contrastive learning, we need to consider what principles need to be followed in the design of positive and negative sample pairs and how to select appropriate data augmentations without resorting to supervised data. In the absence of an understanding of the relationship between upstream and downstream tasks, designing these self-supervised alternative tasks is difficult, which can only be carried out in a trial and error manner, which will greatly hinder the further development of self-supervised learning.

Recently, there have been some theoretical discussions on how self-supervised learning generalizes to downstream tasks. Among them, Arora et al. [482] and Lee [758] et al. established bounds between self-supervised learning loss and downstream loss, but their theory assumes the conditional independence of positive samples, which is too strong and hardly holds in practice. In addition, Tsai et al. [759] and Tosh et al. [760] established an information-theoretical relationship on the mutual information between self-supervised signals and downstream target variables, while Haochen et al. [761] developed guarantees for contrastive learning from the perspective of spectral graph theory. Although these methods avoid the problems of Arora et al. [482], their theories are based on assumptions that are difficult to verify and even harder to be transformed into guidelines of the designing of practical algorithms. Instead, we aim to start from practical self-supervised algorithms, analyze the working mechanism, and establish more practical and effective theoretical analysis and guarantees to provide principled guidance for algorithm design.

## 9.2 Existing studies of interpretability

### 9.2.1 Visually Explaining the Knowledge Learned by Big Models or Illustrating Important Inputs.

Visualizing features inside a deep model is the most direct way to explain the model. The purpose of explanation methods based on visualization is to demonstrate that the model does learn some meaningful features instead of a chaotic system. To this end, some studies visualized features learned by models by using gradients of features [762, 763, 764], or inverting feature maps of convolutional layers into images [765]. Some studies estimated and visualized the attribution/attention/saliency map of inputs to explore important input variables for the model prediction [766, 767, 768, 769, 770, 771, 772]. Besides, it is crucial to conduct a fair comparison among these visualizations. However, due to the lack of ground truth of DNN’s decision-making process, there are still no convincing metrics to evaluate the objectiveness of these visualizations [773]. Only some work investigated and compared the theoretical properties of these (attribution) visualizations [774, 766, 775].

Although the visualization method can help users discover some significant mistakes in the model, it is still far from diagnosing subtle mistakes in the model and improving the representation capacity of models in some complex tasks.

Essentially, the interpretability of big models is not limited to visualization. The main task of explaining big models is to diagnose the potential mistakes in the representation of big models and further correct such mistakes. To this end, the promising direction is to analyze the representation capacity of models from the perspective of either knowledge representations or theoretical analyses.

### 9.2.2 Explaining the Representation Capacity of Models from the Perspective of Knowledge Representation.

The training data, the training method, and the architecture of models do not directly determine the performance of models. Instead, such factors determine the quantity and quality of knowledge points learned by the model, thereby affecting the performance. Therefore, we need to quantify and evaluate knowledge points learned by the model. Previous studies have proposed several methods to quantify the knowledge points encoded in intermediate layers of the model [776, 777]. In terms of evaluating the quality of knowledge points, some studies explored the complexity [778], generalization ability [779], and robustness [780] of different types of knowledge points. Besides, previous studies also evaluated the consistency/similarity of knowledge points between different models [781, 782]. These studies enabled us to evaluate whether the big model is reliable, which may guide the learning of big models.

### 9.2.3 Explaining the Representation Capacity of Models in Theory.

Many studies have been proposed to theoretically explain the representation capacity of deep models, especially the generalization ability and robustness of models. Some studies explained the adversarial robustness of models by exploring why adversarial examples exist [783, 784, 785]. Previous studies [786, 787, 788, 789] proved lower/upper bounds on the adversarial robustness of models. The robustness of models has also been studied and explained from the perspective of game theory [790, 780]. In terms of generalization ability, previous studies evaluated and explained the generalization ability of models from different perspectives [791, 792, 793, 794], including using the stiffness [795], the Fourier analysis [796], the sensitivity metrics [797], and the interaction metrics [779]. Unfortunately, there is still a long way to use the above theoretical explanations to guide the learning of big models to improve the generalization ability and robustness of models.

Vision Transformers (ViTs) (which combine convolutional and attention layers) have exhibited better classification performance than traditional CNNs [625, 798, 799]. Many studies explored the reason for ViTs’ advantages from the perspective of representations [800, 801]. Empirical studies [801] demonstrated that ViTs spatially smoothed feature



representations, *i.e.* averaging feature map values with positive self-attention importances, thereby reducing high-frequency components<sup>1</sup> of feature representations. In contrast, CNNs increased high-frequency components. Besides, ViTs reduced the variance of feature representations; conversely, CNNs increased it.

#### 9.2.4 How to Integrate Knowledge Graphs into Big Models.

The knowledge graph provides rich structured knowledge facts, which benefits big models for knowledge-driven NLP tasks [162], *e.g.* entity typing and relation classification. Therefore, how to integrate knowledge graphs into big models to improve the language understanding of text corpus has received increased attention in recent years. Many studies [162,180,170] separately learned knowledge embeddings and language embeddings, and combined these two types of embeddings during the model training. Such a combination was direct, but knowledge embeddings and language embeddings were difficult to align well in high-dimensional space. To this end, some studies [185,163] proposed to predict knowledge embeddings and language embeddings into a shared semantic latent space by jointly optimizing objectives of the knowledge graph and the language model. Such a joint learning benefited both the learning of knowledge graph and the learning of the language model. In addition, to avoid high-dimensional embedding alignment problem, some studies [182,183] constructed an additional memory to save knowledge facts, and fetched a specific knowledge fact to provide a correct language understanding when the network was processing the corresponding token. Such an entity memory was convenient, and it was easy to add new knowledge facts. There was also research directly inputting knowledge facts and tokens into the model, so as to learn knowledge embeddings and language embeddings simultaneously [184].

### 9.3 Future Directions

#### 9.3.1 More Informative Metrics for the Representation Power of Big Models to Guide the Training Process.

Big models are usually referred to as two terms, *i.e.* a large number of training samples and a large number of model parameters. Although people usually use the loss function to supervise the training of the model, only the scalar loss score is still far from an ideal metric to reflect the representation capacity of the big model. For example, given a big model for the classification of multiple classes, the loss function cannot precisely reflect whether the learning of a specific class has converged, and whether the representation of a class can be further optimized. Therefore, we need a more informative metric to represent the representation capacity of big models to guide the training process of the big model.

In order to have a good knowledge of the representation capacity of a big model, we need more metrics to evaluate the model from the following three perspectives. (1) First, metrics are needed to diagnose the representation capacity of the model on different inputs. As aforementioned, for a model trained for the classification task, a good metric is supposed to show us the representation ability of the model on each specific class. More specifically, for each input sample, a good metric is expected to tell us whether this sample is important for the training, whether the information of this sample is reliable, whether this sample may be incorrectly labeled, and so on. (2) Second, from the perspective of model parameters, we need an informative metric to evaluate parameters in different layers and different kernels. For example, parameters of some layers in a big model may be robust while parameters of other layers are not. The training of some kernels may have converged while other kernels still need further optimization. Such detailed knowledge of the big model will better guide the training of the model. (3) Third, the metric on the level of knowledge points in feature representation of big models is also important. The quantity, quality, generalization ability, convergence situation, and other information about knowledge points learned by the model will help us better understand the representation capacity of the model. In a word, we need informative metrics to understand the big model from various perspectives and guide the model's training.

#### 9.3.2 The Law of Scale

In addition to information metrics, we want to explore the basic theoretical issues of large-scale intelligent computation and study the relationship between model scale, representation, and performance. The goal is to characterize the theoretical limits on the scale and performance of large models and provide theoretical guidance for model design and interpretability research. The main research contents include:

**The law of representation scale.** The study completely presents the limit theory of model scale required for the given data, that is, establishes the law of the binary quantitative relationship between the model scale and the

<sup>1</sup> Here, high-frequency components correspond to the shape of images. In contrast, low-frequency components correspond to the texture of images.

amount of data in the sense of expressing ability. Specifically, given data, there exists a neural network model scale limit. When the scale limit is reached, the data information can be fully represented, and the model scale will not be increased. The quantitative relationship between the model scale limit and the amount of data that the model fully expresses is the law of expressing scale.

**The law of performance scale.** This will study the law of the three-dimensional quantitative relationship between task performance, model scale and data scale. Specifically, the target task performance depends on both the model and the data scales. Based on the qualitative relations, we study the laws of quantitative relations. As a starting point, we first study the simple binary between the fixed model scale (or data scale) and the dependence of performance on another scale factor. We will focus on the study of the ternary law, that is, the law of performance changes when the model scale and the data scale increase simultaneously. The core content is to determine the best relationship between model scale and data scale growth so that performance can increase at the highest rate.

### 9.3.3 Error Localization and Debugging of Big Models.

The current deep learning paradigm mainly uses well-trained big models as the infrastructure and further conducts a large-scale fine-tuning on the big model for various tasks. However, such a fine-tuning paradigm without an in-depth understanding of models is usually not a convincing and promising way to debug internal errors in big models. Instead, it is highly desirable to develop an indicator to localize such errors to accurately conduct targeted debugging of models.

Specifically, how to diagnose and debug a big model in a precise way is also a challenge. First, the diagnosis and debugging are supposed to rely on the communicative learning between concepts encoded in the model and semantic concepts of human cognition. In comparison, the traditional strategy of fine-tuning on massive data is depressing. This is because what really matters in massive data is the density of samples that contain not-well-trained concepts, rather than the total number of training samples. Second, it is necessary to locate errors of the model accurately. For example, we need to find out the specific convolution kernel that causes the errors. Third, we should repair the big model stably. It is not sustainable that when one knowledge point of the model is repaired, other related knowledge points are damaged as side effects.

### 9.3.4 The representation capacity of Big Models.

There is a fundamental question in terms of the representation capacity of big models, *i.e.*, which types of knowledge points are difficult for big models to represent [43,802,803]. It has been generally believed that big models mainly model the correlation between input and output based on regression, but do not perform well in causal reasoning [804]. However, even in the scope of regression can all types of knowledge points be equally well encoded in big models? Some previous studies [803] have discovered a representation bottleneck of DNNs, which pointed out that a DNN was more likely to encode both too simple and too complex knowledge points but usually failed to learn knowledge points of intermediate complexity.

Moreover, it is necessary to explore the knowledge representation further from the following two aspects. First, it is necessary to prove which types of knowledge points are inherently easy to represent in a particular big model architecture. Such research is supposed to explain any arbitrary architectures rather than explaining well-known facts that recurrent neural networks are experts in learning temporal correlations, and the convolutional neural network is suitable for learning spatial correlations in images. Second, it is also indispensable to investigate which types of knowledge points are required by a specific task. We need to integrate both aspects to evaluate the representation capacity of a big model on a task and to guide the architectural design of the big model.

### 9.3.5 Guidance to the design of Big Models.

In recent years, researchers have paid increasing attention to the architectural design of a big model. Neural architecture search (NAS) is a popular approach automatically searching the model architecture for a specific task by optimizing model performance [805,806,807]. However, beyond such an empirical architecture design, the essential problem is theoretical guidance to the architectural design. *I.e.*, how to establish the theoretical connection between the model's architecture and the model's knowledge representation and its performance.

Fundamentally, the performance of a model on a task is a result of both characteristics of the model and demands of the task. Therefore, two key issues of precisely guiding the architectural design of a big model are how to theoretically quantify the representation capacities of various model architectures and how to theoretically quantify the demands of various tasks (*e.g.*, computer vision, natural language processing).

### 9.3.6 Generalization, Robustness, and Knowledge Representation of Big Models.

**Generalization Theories** **Data generalization.** Traditional generalization theory often only involves generalization theory under independent and identically distributed (i.i.d.) supervised data. But in real scenarios, we usually face the difference between training and testing data, such as semi-supervised data, weakly supervised data, unsupervised data and other different types of training data. We should theoretically establish theoretical bounds between pre-training and downstream learning risks and characterize necessary data properties to obtain good generalization.

**Task generalization.** This will study the theoretical conditions and properties of the transferability and generalization of big models. We should characterize the sufficient and necessary conditions for learning in the sense of task generalization, especially the quantitative relationship between BMs, learning tasks, and large-scale data and parameters.

**Scenario generalization.** Since there exists a difference between the training scene and the test scene, especially for application scenes with distribution shifts, we should characterize the ability of out-of-distribution generalization and establish theoretical bounds for scene generalization. That is, develop new algorithms for learning invariant features with theoretical guarantees.

**Explainable AI** The generalization and robustness (see Section 11 for more details of robustness) of DNNs are the core issues of building safe and reliable AI. Most previous studies explored how to improve generalization ability and robustness, while the goal of explainable AI is to reveal the underlying reason behind generalization and robustness, and to clarify the theoretical connections between generalization, robustness, and knowledge representation of a DNN.

Explainable AI pursues an interpretable roadmap of the model performance, rather than merely an empirical black-box DNN. Specifically, explainable AI aims to locate and uncover the factors (*e.g.*, network architecture, training samples) that lead to the flaws in the generalization and robustness of DNNs, *i.e.*, clarifying which factors cause such flaws. Impacts of these factors may be complex and comprehensive. Therefore, we need to further disentangle the compositional impacts from various factors, *i.e.*, measuring the exact utility of factors, such as architectures and training samples. Explainable AI is supposed to give precisely quantified explanations as follows: 30% of the adversarial susceptibility of a test sample is due to the network architecture, and 70% is due to a certain set of training samples.

## 10 Commonsense Reasoning

*Authors: Jing Zhang<sup>✉</sup>, Haoyang Li*

In recent years, the artificial intelligence technology represented by deep learning has basically realized the perceptual intelligence such as vision and hearing, but it is still challenge to achieve the cognitive intelligence such as thinking and reasoning. In the process of solving problems, human can understand the whole process with reasoning paths and nodes, but current deep learning algorithms regard solving most of these problems as a black box. To better simulate the human problem-solving, machine reasoning is an important research direction. In this part, We use commonsense reasoning as an example to introduce the basic reasoning conceptions, involving the definition, methods and benchmarks of commonsense reasoning. At the end of this section, some future directions are proposed.

### 10.1 What is Commonsense Reasoning?

Commonsense is the basic level of practical knowledge [808]. Unlike the encyclopedic knowledge that usually can be explicitly expressed by (head entity, relation, tail entity) triplets, commonsense is an experienced judgment concerning everyday matters and situations or a basic ability to perceive, understand and judge in a manner<sup>2</sup>, which is often implicit, thus it could not be unitedly expressed by the above factual triplets. Meanwhile, the encyclopedic knowledge usually involves specific domain knowledge that can only be understood by domain experts, while commonsense is basic and shared by nearly all people, which is the cornerstone of any academic question or interpersonal communication.

Commonsense reasoning is any reasoning task such as generation [809], question answering [810,811,391], dialogue [812], and classification [813,814,815] that requires commonsense knowledge. For example, to answer the question “The professor has a class all morning. After lunch, what will he do?”, the machine needs to know the commonsense that people usually have a rest after lunch. Table 11 illustrates some other examples of question-answer pairs that require various commonsense knowledge.

---

Jing Zhang (zhang-jing@ruc.edu.cn) is the corresponding author of Section 10.

<sup>2</sup> [https://en.wikipedia.org/wiki/Common\\_sense](https://en.wikipedia.org/wiki/Common_sense)

**Table 11.** Some question answering examples that require commonsense knowledge.

Question	Answer
Bats have many quirks, with the exception of ?	Laying eggs
Does rain make the road dry/slippery?	No/yes
If someone is good at some skills, what can he do?	Teaching his skills to others
A person has worked for a long time, what should he do next?	Taking a rest
Does a chicken have horns?	No

## 10.2 Can Big Models Know Commonsense?

Some works have tried to explore what has big models learned by probing the commonsense knowledge from the big models. Early work [92] surprisingly finds that BERT-base and BERT-large have a strong ability to recall factual knowledge without any fine-tuning, which proves big models have the potential as unsupervised open-domain QA systems. Weir et al. [816] evaluate whether big models trained on large text corpora can capture stereotypic tacit assumptions (STAs) [817], i.e., propositions commonly attributed to “classes of entities”. They observe that big models are effective at retrieving concepts given associated properties. For example, when given “flies” and “has rotating blades” as the input, the big models can infer the description is of a helicopter. Recently, Self-talk [818] tries to probe the knowledge from big models via adding some prompts. Specifically, it defines a number of information-seeking questions such as “what is the definition of ...” as the prompts, uses them to inquire the big models, and then concatenates the answers with the original input as the new input of the big models to probe the answers. They show that this “self-talk” method substantially improves the performance of zero-shot big model baselines on four out of six commonsense benchmarks, and competes with models that obtain knowledge from external knowledge bases.

However, Davison et al. [455] show that, for a commonsense knowledge base completion task, the performance of zero-shot big models is still worse than models explicitly trained on a corresponding training set. Zellers et al. [819] presents a new challenge dataset called HellaSwag for commonsense natural language inference. They show that commonsense inference on HellaSwag is trivial for humans (> 95% accuracy) but still difficult for big models (< 48%). Bisk et al. [820] explore the ability of big models on a physical commonsense question answering data set and show the same result that humans can easily answer the questions (95% accuracy), but big models still struggle (best performance is 77%). Some works investigate the specific capacity of big models. For example, Kassner et al. [821] propose two new probing tasks analyzing factual knowledge stored in big models. The first task is to change the cloze questions to negative (e.g., converting “Birds can [MASK]” to “Birds cannot [MASK]”) and the second task is to add “misprimes” to cloze questions (e.g., converting “Birds can [MASK]” to “Talk? Birds can [MASK]”). They find that big models cannot distinguish between negated and non-negated questions well, and big models also can be easily distracted by misprimes cases. Forbes et al. [457] introduce two new datasets about physical commonsense reasoning, and they find that big models are hard to capture compatibility between affordances and properties. For example, “wear” is an affordance, while “sticky” and “comfortable” are two properties. Humans can easily infer that “wear” is compatible with the property “comfortable” but is incompatible with the property “sticky”. However, it’s difficult for big models to capture their compatibility. They posit that the inference between affordances and properties requires multi-hop reasoning that is not present in the pre-training stage. Talmor et al. [822] propose eight reasoning tasks, which conceptually require operations such as comparison, conjunction, and composition. They find that big models don’t reason in an abstract manner but rely on context, e.g., while ROBERTA can compare ages, it can do so only when the ages are in the typical range of human ages (15-105).

In summary, although big models can obtain certain performance on some commonsense probing tasks, the zero-shot probing performance is still worse than explicitly trained models, and is much worse than Human beings. Among all kinds of commonsense reasoning abilities, some ability such as negation, matching the affordance with the properties and comparison without context is extremely worse.

## 10.3 How to Enable Commonsense Reasoning?

Before the era of big models, people enabled commonsense reasoning by retrieving the evidence for reasoning based on some heuristic rules [823, 824, 825, 826]. For example, some works find the documents containing the topic entities in the task input. However, since the commonsense is rarely explicitly expressed in existing documents, researchers turn to investigate the manually created commonsense resources instead of the raw documents.

With the advances of big models, Some researchers try to directly encode the commonsense knowledge into the parameters of language models (LMs) via pre-training LMs on both the raw documents and the human-created commonsense resources, which enables LMs to better deal with the commonsense-related downstream tasks [168, 827, 828]. These methods abandon the commonsense resources after pre-training. However, purely relying on the underlying

commonsense knowledge encoded in big models to enable the downstream reasoning is difficult, because it is still unknown how to effectively probe the required knowledge from big models [818,821,819,820].

Instead of only providing the task input to the big models, the mainstream idea is to retrieve task-relevant context from the external commonsense resources and encode the task input as well as the context by big models. The context consisting of the commonsense knowledge and the relations between them is usually organized by a subgraph. The task input is usually natural language text, such as the question in a QA task. These two modalities, i.e., the subgraph and the text should be interacted to enable reasoning. Some works treat both the subgraph and the text as the input of big models and rely largely on the reasoning ability of big models [810,391,811,809]. On the contrary, some other works rely heavily on the reasoning ability of the graph neural networks (GNNs) to encode the subgraph, while the text is injected into the nodes or links of the subgraph [829,830]. Recently, some researchers explore using two-tower models consisting of both the big models and the GNNs to encode the text and the subgraph respectively, and then integrate their representations. Compared with the shallow interaction between the two models [812,815,813,811], QA-GNN [831] and GREASELM [832] reinforce the interactions between the two models. Specifically, QA-GNN treats the output representation of the big models as a special node in GNNs, while GREASELM outputs a special token’s representation by big models and a special node’s representation by GNNs, and adds an additional interaction layer after each GNN convolution layer to combine both the special representations.

## 10.4 Resources and Benchmarks

Some sociologists have found that humans reason about the world with mental models [833], which consist of personal experiences [834] and world knowledge and commonsense [835]. It’s hard for big models to learn personal experiences in the real world, but relatively easy to obtain world knowledge and commonsense from additional resources. There are 5 commonsense resources in the form of knowledge bases (KBs):

- ConceptNet5.5 [174]: ConceptNet5.5 is one of the most widely used commonsense KBs focusing on taxonomic and lexical knowledge (e.g., RelatedTo, Synonym, IsA) and physical commonsense knowledge (e.g., MadeOf, PartOf). ConceptNet5.5 contains 34 relations and 3.4M tuples, and it is collected by crowdsourcing and merged with existing knowledge databases from DBPedia, WordNet, Wiktionary, and OpenCyc.
- ATOMIC [175]: ATOMIC, containing 9 relations and 880K tuples, is collected completely through crowdsourcing. However, ATOMIC only contains social commonsense knowledge.
- ATOMIC2020 [836]: ATOMIC2020 extends ATOMIC to 23 relations and 1.33M tuples covering social, physical, and temporal aspects of everyday inferential knowledge. ATOMIC2020 is constructed by crowdsourcing and integrates some tuples from ATOMIC and ConceptNet5.5.
- WebChild [837]: WebChild presents a method for automatically constructing a large commonsense KB consisting of 19 relations and more than 4M tuples.
- WebChild2.0 [838]: WebChild2.0 is presented to automatically construct a large commonsense KB using a series of algorithms to distill fine-grained disambiguated commonsense knowledge from a massive amount of text. WebChild2.0 is one of the largest commonsense KBs available, which covers over 2M disambiguated concepts and activities, connected by over 18M assertions.

In addition to the above commonsense resources, researchers have created many commonsense benchmarks to evaluate the ability of commonsense reasoning. Different benchmarks require models to complete different tasks and understand different types of commonsense knowledge. We summarize the widely used commonsense reasoning benchmarks and show them in Table 12.

## 10.5 Challenges and Future Directions

It is still far from optimal for big models to perform commonsense reasoning. The first possible reason is that big models haven’t encoded sufficient commonsense knowledge. Some works [854,185,855,162] explore knowledge-enhanced big models, where encoding commonsense KBs into the parameters of big models has also been particularly investigated [171,856,857]. In addition to the explicitly summarized commonsense knowledge in the existing commonsense resources, visual information may also help machines to perform commonsense reasoning, since humans can easily summarize commonsense from images or videos. For example, given a question “How many eyes does the sun have?”, we can easily answer “The sun has no eyes.” because the sun doesn’t have eyes in common pictures. However, there is no explicit knowledge about this question in the existing commonsense resources. Incorporating the additional visual information might be a potential solution for improving the knowledge-enhanced big models. The other possible reason is a suitable approach to probe the required commonsense from the big models is missing. Recently, prompt-based learning [316] is a new paradigm in natural language processing that allows us to perform few-shot or even zero-shot learning on the basis of big models without fine-tuning. Some hard/soft prompt-based methods [20,92,319,320] are

**Table 12.** Benchmarks for commonsense reasoning.

Benchmarks	Types	Tasks
PIQA [820]	Physical commonsense	Question answering
HellaSwag [819]	Physical commonsense	Commonsense inference
SWAG [839]	Physical commonsense	Commonsense inference
JOCI [840]	Physical commonsense	Ordinal commonsense inference
ART [841]	Physical and social commonsense	Commonsense inference
CSQA [842]	Physical and social commonsense	Question answering
Social IQA [843]	Social commonsense	Question answering
ROC Stories [844]	Social commonsense	Story cloze
Psychology [845]	Social commonsense	Classification and generation
WSC [846]	Social commonsense	Question answering
COPA [847]	Social commonsense	Question answering
VCR [848]	Social commonsense	Visual commonsense reasoning
WINOGRANDE [849]	Social commonsense	Question answering
MCTaco [850]	Temporal commonsense	Question answering
ReCoRD [851]	All types mentioned above	Reading comprehension
Cosmos QA [852]	All types mentioned above	Reading comprehension
MultiRC [853]	All types mentioned above	Reading comprehension

proposed to elicit knowledge from big models to perform various tasks, and some of them even outperform the prior state-of-the-art (SOTA) fine-tuning approaches. Thus the prompt-based methods might be effective ways to probe the commonsense from big models.

Beyond enhancing the big models, we can also improve the retrieval-based commonsense reasoning models such as QA-GNN [831] and GREASELM [832]. These methods heuristically retrieve a subgraph from the external commonsense resources that can include the entities mentioned in the question and the answer choice. The subgraph is either too large to include many noises or cannot cover adequate evidence. Thus, extracting a high-quality subgraph is crucial for improving the following reasoning performance, which is worth studying in the future. In addition, the above-mentioned visual information is also a good supplement for the commonsense knowledge that is not explicitly described in the text and KBs [858, 838]. To effectively leverage the visual information, how to retrieve the relevant images and incorporate them into the commonsense reasoning model should be mainly investigated.

## 11 Reliability and Security

*Authors: Yinpeng Dong<sup>\*</sup>, Tianyu Pang<sup>\*</sup>, Hang Su<sup>✉</sup>, Jun Zhu<sup>✉</sup>*

The increased adoption of recent emerging Big Models presents an opportunity to solve many social and scientific challenges, which brings an increasing commoditization of face recognition, machine translation as well as the information retrieval. The AI technology is moving from research labs to our daily life at an unprecedented level. Nevertheless, the progress could be hindered if we do not consider to secure the AI-enabled technologies. It gradually reach a consensus that the AI systems exposes new vulnerabilities, but the community still lacks comprehensive understanding about the nature of these model vulnerabilities. In this part, we systematize the recent achievements in terms of the security and privacy of big models.

- In Section 11.1, we introduce different kinds of reliability and security problems and divide the vulnerability of models into different stages.
- In Section 11.2 and 11.3, we explain adversarial vulnerability and data poisoning respectively and summarize their corresponding defensive measures.
- In Section 11.4, we discuss several directions of big models’ reliability and security that can be further developed.

---

Yinpeng Dong and Tianyu Pang contribute equally.

Hang Su (suhangss@mail.tsinghua.edu.cn) and Jun Zhu (dcszj@mail.tsinghua.edu.cn) are the corresponding authors of Section 11.

## 11.1 Background

Most of the deep models including the recent big models have demonstrated to be vulnerable to the sophisticated attack techniques with which an adversary can violate the confidentiality, integrity or availability of an AI model [859] as is illustrated in Fig. 24. In particular,

- **Confidentiality.** An attack on confidentiality is to gather the internal information of the dataset or the AI models, which can be used to conduct more advanced attacks consequentially.
- **Integrity.** An attack on integrity is to modify the logic or to control the output of an AI model by interacting with the AI system. The complexity of attacks is increasing with confidence reduction, misclassification, targeted misclassification and source-target misclassification [860].
- **Availability.** An adversary aims to disable the system’s functionality with the purpose of attacking the availability of an AI solution, which can be achieved by by poisoning the data, corrupting the models or tampering with the output.

In summary, the security threats becomes an urgent issue in the development and application for artificial intelligence, which is highly related to the data and structural elements of an AI system. According to the different phases in the AI systems, we elaborate on the corresponding vulnerabilities and their corresponding countermeasures as

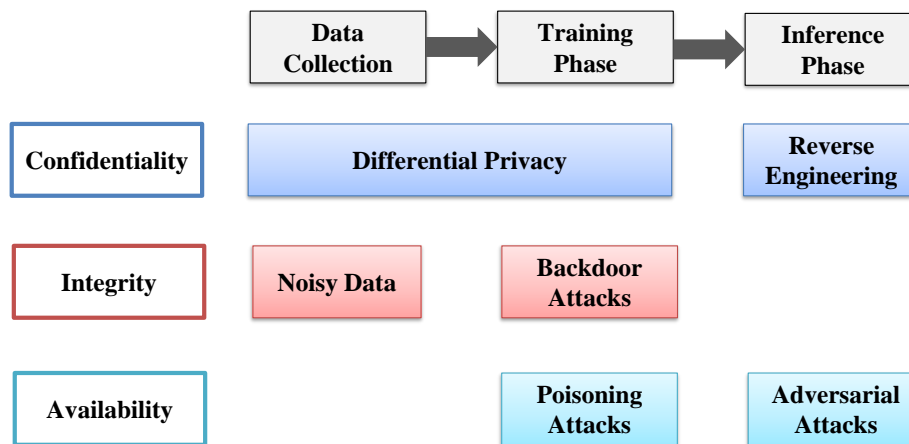

Fig. 24. The general framework of security issues in different phrases of an AI system.

- **Data Collection Phase**— As a driving force behind the rapid development of artificial intelligence, most of the existing data collection technologies cannot meet the requirement of security including confidentiality, integrity, authentication as well as privacy protection [861].
- **Training phase attacks**— An adversary seeks to learn, influence or degenerate the performance. The most straightforward attack is to inject malicious data into the training data, which can change the original data distribution by poisoning the data or label, thereby misleading the model to make incorrect predictions. Besides, an adversary can also conduct a logic corruption by manipulating the learning procedure if it can access the internals of an algorithm.
- **Inference phase attacks**— An adversary can also conduct the exploratory attacks in the testing phase, which can be categorized into black-box and white-box attacks. In a white-box scenario, the adversary has a full knowledge of the architecture, parameters, as well as the intermediate computation in the models. On the other hand, the adversary has no access to the model parameters or architecture of the model, but it allows the adversary to query the model to infer the necessary information.

It has witnessed significant progress in the security issue in deep learning, but this problem becomes much more serious in the era of Big Model to some extent. Compared to the previous deep learning models, big models need to use several orders of magnitude more data, and the number of model parameters is much larger, yielding a much more complex structure. These facts makes the detection of vulnerabilities more complicated. It has motivates the concerns for adversarial machine learning with the purpose to develop more robust deep learning techniques that can be resilient to various types of adversarial attacks. In this section, we provide a holistic review of the security of big models that demonstrate different hacking techniques against various AI applications. We highlight the important work in understanding the adversarial goals as well as the attack and defense techniques to assess the AI security. Finally, we provide the main challenges and future research directions in AI security and privacy.

## 11.2 Adversarial Vulnerability

Although machine learning (ML) has obtained unprecedented progress in various tasks, a standardly well-performed ML model can be vulnerable in the adversarial setting [862, 783, 786], where adversarial examples are maliciously generated to mislead the model to return wrong outputs. Unlike common corruptions, adversarial perturbations are constrained to be *imperceptible* to human eyes (e.g., in vision tasks) or human readers (e.g., in NLP tasks). This imperceptibility is the main characteristic that makes adversarial vulnerability counter-intuitive and intriguing. As ML is becoming ever more prevalent, having adversarially robust models may not be a sufficient but is a necessary condition towards generally reliable systems, especially in safety-critical applications [863].

### 11.2.1 Threat models

Before talking about robustness, we first need to clarify the threat model. Namely, an unrestricted attacker (e.g., allowed to arbitrarily modify image pixels) can trivially fool a ML model, which is not what we want to defend against. Following the definitions in [864], a threat model specifies the conditions under which a defense is designed to be secure and the precise security guarantees provided. A threat model includes a set of assumptions about the adversary’s *goals* (e.g., targeted or untargeted), *knowledge* (e.g., white-box or black-box), and *capabilities* (e.g., maximal perturbation  $\epsilon = 8/255$  under  $\ell_\infty$ -norm). For detailed definitions and guidelines in the adversarial literature, we refer the interested readers to [864].

### 11.2.2 Attacks

There are many adversarial attacks proposed under different threat models.

**White-box attacks.** Most white-box attacks craft adversarial examples based on the input gradient. The fast gradient sign method (FGSM) [783] linearizes the loss function in the input space and generates an adversarial example by an one-step update. The basic iterative method (BIM) [865] extends FGSM by iteratively taking multiple small gradient steps. Similar to BIM, the projected gradient descent method (PGD) [866] acts as a universal first-order adversary with random starts. DeepFool [867] has been proposed to generate an adversarial example with the minimum perturbation. The Carlini & Wagner’s method (C&W) [868] takes a Lagrangian form and adopts Adam [869] for optimization. However, some defenses can be robust against these gradient-based attacks by causing obfuscated gradients [870]. To circumvent them, the adversary can use BPDA [870] to provide an approximate gradient when the true gradient is unavailable or useless, or EOT [871] when the gradient is random.

**Transfer-based black-box attacks.** Transfer-based attacks craft adversarial examples against a substitute model, which are probable to fool black-box models based on the transferability. Several methods have been proposed to improve the transferability [872]. The momentum iterative method (MIM) [873] integrates a momentum term into BIM to stabilize the update direction during the attack iterations. The diverse inputs method (DIM) [874] applies the gradient of the randomly resized and padded input for adversarial example generation. The translation-invariant method (TI) [875] further improves the transferability for defense models.

**Score-based black-box attacks.** Under this setting, although the white-box access to the model gradient is unavailable, it can be estimated by the gradient-free methods through queries. ZOO [876] estimates the gradient at each coordinate by finite differences and adopts C&W for attacks based on the estimated gradient. NES [877] and SPSA [878] can give the full gradient estimation based on drawing random samples and acquiring the corresponding loss values. Prior-guided random gradient free method (P-RGF) [879] estimates the gradient more accurately with a transfer-based prior.  $\mathcal{N}$ ATTACK [880] does not estimate the gradient but learns a Gaussian distribution centered around the input such that a sample drawn from it is likely adversarial.

**Decision-based black-box attacks.** This setting is more challenging since the model only provides discrete hard-label predictions. The Boundary attack [881] is the first method in this setting based on random walk on the decision boundary. An optimization-based method [882] formulates this problem as a continuous optimization problem and estimates the gradient to solve it. The evolutionary attack method [883] is further proposed to improve the query efficiency based on the evolution strategy.

### 11.2.3 Defenses

To alleviate the adversarial vulnerability of deep learning models, many defense strategies have been proposed.

**Adversarial training.** The idea of adversarial training (AT) stems from the seminal work of [783], while other AT frameworks like PGD-AT [866] and TRADES [884] occupied the winner solutions in the adversarial competitions [885,



886,887,888]. Based on these primary AT frameworks, many improvements have been proposed via encoding the mechanisms inspired from other domains, including ensemble learning [889,890], metric learning [891,892,893,894], generative modeling [895,896,897,898], weight perturbing [899], semi-supervised learning [900,901,902], and self-supervised learning [903,904,905,906]. On the other hand, due to the high computational cost of AT, many efforts are devoted to accelerating the training procedure via reusing the computations [907,908], adaptive adversarial steps [909,910] or one-step training [911,912,913]. The following works try to solve the side effects (e.g., catastrophic overfitting) caused by these fast AT methods [914,915,916]. Recently, several works highlight the importance of training tricks [917,918] and extra generated data [919] for AT methods, which further push forward the state-of-the-art performance of adversarially trained models.

**Certified defenses.** Other more theoretically guaranteed defense routines include training provably robust networks [920,921,787,922,923]. These methods are mostly based on convex relaxation for fast model verification, and differentiable end-to-end training. Recently, a popular routine towards certified defenses is using randomized smoothing [924,925,926,927,928], which is scalable to large-scale datasets like ImageNet. While these methods are promising, they currently requires expensive computation or do not match the state-of-the-art robustness under empirical evaluations.

**Inference-phase defenses.** Many previous methods try to solve this problem in the inference phase, by introducing transformations on the input images. These attempts include performing local linear transformation like adding Gaussian noise [929] or global linear transformation like mixup [930], where the processed inputs are kept nearby the learned feature manifolds, such that the classifiers can maintain high performance on the clean inputs. Another category of these attempts is to apply various non-linear transformations, e.g., different operations of image processing [931,932,933] or denoiser [934]. They are usually off-the-shelf for different classifiers, and generally aim to disturb the adversarial perturbations.

**Adversarial detection.** Instead of correctly classifying adversarial inputs, another complementary research routine aims to detect / reject them [935,936,937,938,939,940]. Previous detection methods mainly fall into two camps, i.e., statistic-based and model-based. Statistic-based methods stem from the features learned by standardly trained models. These statistics include density ratio [941], kernel density [942,943], prediction variation [944], mutual information [945], Fisher information [946], local intrinsic dimension [947], and feature attributions [948]. As for the model-based methods, the auxiliary detector could be a sub-network [949,950], a Gaussian mixture model [951], or an additional generative model [952].

#### 11.2.4 Benchmarks

Due to the large number of proposed defenses, several benchmarks have been developed to rank the adversarial robustness of existing methods. [953] perform large-scale experiments to generate robustness curves, which are used for evaluating typical defenses. [954] propose AutoAttack, which is an ensemble of four selected attacks. They apply AutoAttack on tens of previous defenses and provide a comprehensive leader board. [955] propose MAMA based on training meta optimizers, which is computationally more efficient than AutoAttack with comparable attacking effectiveness. [956] propose the black-box RayS attack, and establish a similar leader board for defenses. Except for the adversarial robustness, there are other efforts that introduce augmented datasets for accessing the robustness against general corruptions or perturbations. [957] introduce MNIST-C with a suite of 15 corruptions applied to the MNIST test set, while [958] introduce ImageNet-C and ImageNet-P with common corruptions and perturbations on natural images. Evaluating robustness on these datasets can reflect the generality of the proposed defenses, and avoid overfitting to certain attacking patterns [959,960].

#### 11.2.5 Situations in Big Models

Most of the existing works on defense focus on smaller datasets like CIFAR-10, since even after exploiting extra data like 80M TinyImages (or 100M DDPM generated data) and large CNN architecture like WRN-70-16, the state-of-the-art robust accuracy on CIFAR-10 under  $(\ell_\infty, 8/255)$  threat model is still less than 67%, as reported in RobustBench [961].

In NLP tasks, [461] propose TextFooler as a black-box attack against BERT, while [962] demonstrate that BERT is not robust to misspelling and thus can generate natural adversarial examples. Following works craft adversarial examples based on BERT itself [464,463] or using generative models [963]. To this end, several defenses are proposed to learn robust language models, by adversarial training [964,965,966,967], contrastive learning [968,969] postprocessing [970]. On the other hand, large models are usually pretrained on large-scale private datasets, which could contains sensitive information. [42] propose an extraction attack against GPT-2 that can extract hundreds of verbatim text sequences from the model’s training data. These extracted examples include (public) personally identifiable information (names, phone numbers, and email addresses). Moreover, they find that *larger models are more vulnerable than smaller models*. Following work shows that a BERT pretrained on clinical notes can also be attacked to reveal personal

health information [971]. Although these works belong to privacy leakage, the attacking technology is mostly similar as adversarial attacks.

Since Vision Transformers (ViT) become prevalent [28], several papers aim to study whether the architecture of Transformers bring us better robustness beyond CNNs. Specifically, ViT are more robust to naturally corrupted patches than CNNs [691,972,973], while [974] find that ViT are more vulnerable to adversarial patches. In contrast, [975] and [976] observe that ViT are more robust than the CNN models, but MLP-Mixer is extremely vulnerable to universal adversarial perturbations. [977] find that CNNs can easily be as robust as Transformers on defending against adversarial attacks, if they properly adopt Transformers' training recipes. Adversarial transferability is shown to be not significant between CNNs and ViT [978], while following works aim to craft more transferable adversarial examples against ViT [979,980]. On the other hand, defenses adapted to ViT are also proposed [981,982,983,984], considering special architecture designs of ViT. Overall, since there are many new factors (e.g., self-attention, patch stem, LAMB optimizer, new training recipe, etc.) in the success of ViT, comprehensive ablation studies are necessary for a fair evaluation on the effects of different factors.

### 11.2.6 Adversarial for Good

In addition to security topics, recent progresses demonstrate many positive applications of adversarial techniques, which is also highly concerned by the community.<sup>3</sup> For examples, [985] propose AdvProp, an enhanced adversarial training scheme which prevent overfitting and enhance an EfficientNet-B8 to achieve 85.5% ImageNet top-1 accuracy without extra data. [986] adversarially robust models, while less accurate, often perform better than their standard-trained counterparts when used for transfer learning. [987] use adversarial training methods to improve machine reading comprehension. [988] exploit adversarial attacks to generating adversarial identity masks, in order to protect user privacy. Adversarially robust models also have more semantic input gradients, which can connect with generative learning methods like score matching [989,990,991,992] and SGLD [993,994].

## 11.3 Data Poisoning

An important factor leading to the success of machine learning (ML) systems is the adoption of large-scale datasets. In the era of big models, the training datasets also grow in scale, which requires the practitioners to collect much more training data to achieve state-of-the-art performance. These datasets are usually crawled on the web or collected through outsourcing. However, the adversary can easily manipulate the data collection process to inject poisoned samples into the dataset, making the trained model behave abnormally to satisfy the adversary's goal. Contrary to adversarial attack which aims to mislead an ML model during inference, poisoning attack happens in the training stage [995]. From the industry perspective, poisoning attack is the most worrisome security threat than other threats (e.g., adversarial attack) [996]. In the following, we introduce typical data poisoning attacks and defenses, and then discuss the threats of data poisoning for big models.

### 11.3.1 Training-only Poisoning Attacks

This type of data poisoning attacks only manipulate training data and labels without the need to modify testing data after the victim model is deployed. Training-only poisoning attacks include both untargeted attacks where the adversary aims to degrade model performance on normal testing data [995,997,998,999], and targeted attacks in which the adversary aims to change the behavior of the model on particular testing inputs [1000,1001,1002]. Below we introduce some typical approaches.

**Bilevel Optimization.** Data poisoning can be generally formulated as a bilevel optimization problem, in which the inner optimization aims to train the model parameters given the poisoned dataset, while the outer optimization aims to optimize the poisoned samples given the model parameters of the inner problem. Early works can solve the bilevel optimization problem exactly for classical ML models, including support vector machines [995], regression models for feature selection [1003], etc. In the context of neural networks, since the inner problem is usually non-convex and intractable, most methods adopt variants of gradient descent to approximately solve the bilevel optimization problem, including back-gradient descent [1004] and influence functions [997]. It is usually computationally expensive to solve the bilevel optimization problem, which motivates further work to adopt generative models to produce poisoned samples [1005,1006]. After training a generative model, the poisoned samples can be simply generated by a forward pass, requiring much less computational effort.

<sup>3</sup> <https://advml-workshop.github.io/icml2021/>

**Clean-label Targeted Attacks.** [1000] propose a specific kind of poisoning attacks called clean-label targeted attacks. The attack objective is to perturb training data such that a particular testing input is misclassified to a target class. To this end, [1000] propose a feature collision attack method, which perturbs a small set of training images of the target class to make their feature representations close to that of the testing image. By training on these perturbed samples, the decision boundary of the model probably cross over the testing image, and thus misclassifying the testing image. Note that this method does not need to modify the ground-truth labels of the training images, such that they are clean labels. A further method makes the poisoned images surround the testing image in the feature space, such that the feature representations of the poisoned samples are the vertices of a convex polytope containing the feature of the testing image [1001]. This method can achieve better performance and transferability than the feature collision method.

**Poisoning Attacks on Real-Time Data.** Practical systems are more usually trained/fine-tuned on sequentially captured real-time data, in which case poisoning adversaries could dynamically poison each data batch according to the current model state [1007,1008]. A vanilla online poisoning attack [1007] greedily feeds the model with poisoned data, and a monitor could stop the training process after observing a gradual decline of model accuracy. However, it applies a greedy strategy to lower down model accuracy at each update step, which limits the step-wise destructive effect. Recent work [999] proposes accumulative poisoning attacks, where the model states are secretly (i.e., keeping accuracy in a reasonable range) activated towards a trigger batch by the accumulative phase, and the model is suddenly broken down by feeding in the trigger batch, before the monitor gets conscious of the attacks.

### 11.3.2 Backdoor Attacks

Different from training-only poisoning attacks, backdoor (Trojan) attacks [1009,1010,1011] modify both training and testing data. Specifically, backdoor attacks aim to embed a backdoor in a model by injecting poisoned samples into its training data. The infected model performs normally on clean inputs, but whenever the embedded backdoor is activated by a backdoor trigger, such as a small pattern in the input, the model will output an adversary-desired target class.

**BadNets.** [1009] propose the first backdoor attack on image classification — BadNets, where the backdoor trigger is constrained to a small cluster of pixels. BadNets first randomly select a small portion of training images, then attach the trigger pattern to these images and change their ground-truth labels to the target one. By training on the poisoned dataset, the model can capture the relationship between the backdoor trigger and the target class, such that the model will output the target class for any input with the backdoor trigger.

**Invisible Backdoor Attacks.** [1010] consider a more realistic threat model in which the backdoor trigger should be invisible to human observers to achieve stealthiness. To this end, a blending strategy is proposed, which performs weighted average of the original images with the backdoor trigger. This work also demonstrates the possibility of backdoor attacks with a random noise as the trigger pattern, which further reduces the risk of being detected. Further work also proposes other stealthy backdoor attacks [1012,1013].

**Clean-label Backdoor Attacks.** Most work on backdoor attacks needs to modify the ground-truth labels of the poisoned samples in the training set. However, these attacks assume that the adversary can manipulate the labeling process. These poisoned samples can also be easily detected by humans who manually inspect the training dataset. Therefore, [1014] propose clean-label (aka. label-consistent) backdoor attacks, where the labels of poisoned samples are kept correctly. Under this setting, the trigger needs to be added to images belonging to the target class. To make the model learn to recognize the trigger than the original content, [1014] further propose to use either generative model or adversarial examples to make the image content hard to recognize, such that the model will learn a connection between the trigger pattern and the target label.

**Physical Backdoor Attacks.** Backdoor attacks can also be deployed in the physical world, which could pose more realistic threats to practical ML services. [1010] first demonstrate physical backdoor attacks on face recognition. They adopt an eyeglass as the backdoor trigger, which can be printed and attached on a real human face. Then the face recognition model would misclassify the face photos taken by a camera. Further exploration of physical backdoor attacks on face recognition is discussed in [1015].

**Backdoor Attacks on Other Domains.** Beyond computer vision tasks (e.g., image classification, face recognition, etc.), backdoor attacks have also been successfully applied to other domains, including natural language processing (NLP) [470,1016], reinforcement learning [1017], and speech recognition [1018]. For example, in NLP, a backdoor trigger can be realized by modifying a particular character, word, or sentence in the training dataset [470], such that the model behaves as the adversary specifies whenever the trigger appears, similar to BadNets. The existence of backdoor attacks on a wide range of domains demonstrates the vulnerability of current methods.

### 11.3.3 Defenses

In this section, we introduce defense mechanisms for mitigating data poisoning attacks, especially backdoor attacks.

**Detecting Poisoned Data.** This kind of defenses aims to distinguish poisoned samples from natural samples. After identifying the poisoned samples, the model can be retrained on the remaining natural samples to avoid being attacked by the poisoned data. [1019] find that backdoor attacks tend to leave behind a spectral signature in the covariance matrix of feature representations, and perform singular value decomposition to identify poisoned samples. [1020] propose an activation clustering method which first clusters the feature representations of training data, and then determines whether any cluster belongs to poisoned samples. As backdoor trigger is input-agnostic, [1021] propose to filter out poisoned samples by superimposing various image patterns and judging the randomness of the predicted probabilities. This kind of defenses needs access to the poisoned samples.

**Detecting Poisoned Models.** Some defense methods aim to distinguish whether a model has been poisoned or backdoored. [1022] propose Neural Cleanse, which can detect backdoored models by reverse-engineering the trigger for every class. It formulates an optimization problem to generate the minimal trigger and detects outliers based on the  $L_1$  norm of the restored triggers. Subsequent methods further design new optimization problems [1023,1024] or modeling the distribution of triggers [1025]. These methods usually require white-box access to the model gradients to optimize the trigger. However, in a more realistic scenario, we need to detect backdoored models under the black-box setting, in which only query access to the model is available. To address this issue, [1026] propose a black-box backdoor detection method, which adopts a gradient-free optimization approach to reverse-engineer the trigger. Besides, some work [1027] proposes to adopt meta-learning to detect backdoored models.

**Pre-processing-based Defenses.** This type of defenses pre-process the testing inputs before feeding to the model such that the backdoor trigger can be made ineffective. [1028] first propose to exploit pre-processing as the defense, in which an auto-encoder is adopted. [1029] further propose Februous, which first identifies critical regions for prediction, and then adopts generative models to reconstruct the regions. Recently, [1030] find that natural image transformations can significantly affect the performance of backdoor attacks, indicating that the simple transformations can be used as effective pre-processing techniques.

**Robust Training.** This type of defenses aims to train robustly in the presence of poisoned samples. Some work [1031,1032] propose to extend randomized smoothing [924], a famous technique for certifying adversarial robustness, to certify robustness under label flipping attacks and backdoor attacks. These methods can provide theoretical guarantee of model robustness under attacks.

### 11.3.4 Threats for Big Models

Training big models usually requires datasets with much larger scales, which are even noisy and uncurated. Although it is much cheaper to collect such datasets than labeling datasets manually, the use of large and even noisy datasets can pose more threats under data poisoning attacks since it is much easier for adversaries to manipulate a portion of training data and also much harder for humans to inspect the poisoned samples individually. We have seen some successful data poisoning attacks on big models, including those on computer vision and natural language processing tasks.

**Computer Vision.** Big models in computer vision commonly adopt self-supervised learning to pre-train an image encoder with a large amount of unlabeled images or image/text pairs. The pre-trained image encoder can be viewed as a feature extractor to build classifiers for downstream tasks. [1033] propose the first backdoor attack to self-supervised learning, named BadEncoder, which injects the backdoor behavior into the pre-trained image encoder to make the downstream classifiers simultaneously inherit the backdoor behavior. BadEncoder shows success on CLIP, a big image encoder pre-trained on 400 million image/test pairs collected from the Internet. [1034] also study poisoning and backdoor attacks on contrastive learning, a typical kind of self-supervised learning technique. This work finds that poisoning and backdoor attacks are much easier on contrastive learning, which require  $100\times$  less modification of the training dataset compared to fully supervised training.

**Natural Language Processing.** Backdoor attacks have also been successfully applied to BMs on NLP tasks. For example, [1035] and [1036] simultaneously propose backdoor attacks on pre-trained NLP models, such that the downstream tasks after fine-tuning can also inherit the backdoor behavior. [1037] propose a weight poisoning approach that the pre-trained weights are injected with vulnerabilities which expose backdoors after fine-tuning.

Although there are less works on studying data poisoning attacks and backdoor attacks on big models, they are potentially more harmful due to the following reasons:

- Training big models usually requires much more training data, which may be noisy and unlabeled, such that the poisoned samples are hard to detect by humans.
- The poisoning/backdoor behavior can be hidden in the BM, and be activated by fine-tuning on a downstream task.
- It is much harder to defend against data poisoning and backdoor attacks with the existing methods, since they may suffer from a scalability issue for larger models.

Therefore, it is of great importance to further explore data poisoning attacks and backdoor attacks on big models, which can consequently help to understand the potential vulnerabilities of big models as they become more and more prevailing.

## 11.4 Challenges and Future Directions

As the big models are poised to enter mission-critical fields related to human well-being and life at stake, it requires the corresponding technologies with prerequisites for safety and reliability. Due to the lack of verification technologies for DNNs, most of the current big models are evaluated through the performance of the test set, lacking of comprehensive evaluation on the security or robustness. Although there are a series of new technologies that study the vulnerabilities and detect malicious behaviors on the DNN models, adversarial agents can deceive the deep models by significantly changing the response of these system. Although not alarmist, it is the responsibility to preemptively study and establish protective measures for the big models, especially when tasks are critical to the human safety. However, the previous works in this area are fragmented across multiple research communities, ranging from the AI community to information security, and it is imperative to develop a unified framework to study the security issues of big models.

### 11.4.1 Integration of more Comprehensive Knowledge

In essence, the big models are data-driven, which take the data-driven approach to the extreme by using several orders of magnitude more data than the traditional methods. However, an important limitation of the current large model is that it ignores the use of domain knowledge, which is one of the essential reason for the lack of robustness and security of deep learning models. For example, an AI model like GPT-3 does not have any explicit common sense knowledge or clear reasoning. In order to build a robust and powerful AI model, we must have a symbolic manipulation mechanisms which can provide the model the capability in abstract reasoning.

### 11.4.2 Inherently Reliable and Safe Design

The attacker undermined the integrity of the decision-making process by compromising and controlling the AI system itself, or by changing the input. It requires rigorous testing before deployment especially for the big model systems applied in safety-critical areas. Due to the complexity of the big models, formal verification is nontrivial, and in a lot of cases, actual testing during development may be dangerous. Therefore, it is essential to develop the simulation-based technology to conduct the testing, which includes identifying the disturbances that can cause the system failures, finding the most likely failures, as well as estimating the corresponding probability. It require an interdiscipline research in the areas of machine learning, optimization, path planning, etc.

### 11.4.3 Adversarial Robustness and Detection

Recent research demonstrates that the ML systems are vulnerable to the adversarial attacks which are designed to destroy the integrity of their decisions by maliciously altering the training data or the model input. Currently, there is no consensus solution that can prevent the evasive attacks effectively. There still exist many open challenges including how to understand the inner mechanism of the adversarial examples and how to design and develop systems that can certified defense the potential adversarial examples. It is essential to design new machine learning models, use sources to track fraudulent data, and build a system that can withstand the different types of adversarial attacks.

### 11.4.4 Shared Learning on Confidential Data

It has witnessed a rapid advance in big models which use very large model architectures and train on massive datasets. Nevertheless, the big models also have potential risk on the confidentiality and privacy. In other words, an attacks may lead to the exposing of the private information about the model or training data. Recent works has demonstrated that an adversary can predict whether or not a particular examples was in the training data using the membership inference. Therefore, as the big models are widely adopted, it should address the training data memorization issues, and it is expected that these vulnerabilities will become serious in the future. Therefore, it will be essential to develop new methods that can train models on confidential data at an extreme scale without sacrificing model accuracy.

### 11.4.5 Life-long Learning in Big Models

It is known that when these systems are applied to the environment in which they are trained, the models usually work very well. Nevertheless, if the environment is different, sometimes even a small difference, the performance may degenerate significantly. As the big models will be increasingly deployed in dynamic environments, it requires the model to have a capability in adapting and learning new skills as the environment evolves. It therefore requires the model to learn over a lifetime by efficiently and effectively retaining the knowledge they have learned, which is used to learn new tasks.

## 12 Big Model Governance

*Authors: Peng Cui, Lingxiao Huang, Zheng Liang, Huawei Shen, Hui Zhang, Quanshi Zhang*

The fast development of big model and related technologies benefits many AI researches and applications. However, the “double-edged sword” effect appears simultaneously, which means the big model also causes some potential problems, such as privacy leakage and unfair outputs. That means, big model governance is needed for balancing the fast development and technical safety. In this part, we intend to provide clear explanations for big model governance and introduce some present work and future directions.

- In Section 12.1, we introduce the basic conceptions of big model governance and give the objectives of it.
- In Section 12.2, we summarize the existing governance work aiming at different objectives mentioned in the last section.
- In Section 12.3, we propose some open problems of governance and discuss further development both from global view and object-specific view.

### 12.1 Background

#### 12.1.1 What is Big Model Governance

Governance encompasses the whole ways in which public or private organizations operate and administer their common affairs. Governance is an ongoing process to reconcile conflicts, adjust divergent interests, and take joint actions. The critical point to ensure the successful implementation of this process is the construction of institutions that not only includes the formal institutions and regulations that can compel compliance by stakeholders but also contains the informal institutions and regulations that can reach common agreement among stakeholders [1038]. Governance requires cooperation between the public and private sectors. It also requires multiple stakeholders to use their power in a limited way through interactive activities. This is different from traditional governance, which emphasizes government as the sole authority [1039].

Due to the scientific and technological characteristics of the big model, the big model governance also should take the general paradigm of technology governance as an example. The theory of technology governance goes further during the era of Smart Digital. Which depends on the response and governance of the application and influence of digital technology and intelligence technology, and then taking advantage of technology tools to apply different stakeholders into various governance fields, such as national governance [1040], social governance [1041], and industrial governance [1042,1043].

Therefore, the “big model governance” should be defined as evaluating, guiding, and supervising the whole process of big models’ data collection, data set construction, algorithm design, model training, and practical application of models. Meanwhile, it will promote the innovation of big model technology, construct the guidance of safety applications, and build ethical norms.

#### 12.1.2 Why Need Big Model Governance

As the General Purpose Technology (GPT) [1044], Artificial Intelligence (AI) plays the technology engine role of national economic and social development [1045]. Artificial Intelligence includes an obvious Multiplier Effect in its development [1046]. The big model governance is the ecological core of the future of AI. The fundamental reason we should promote big model governance is that this type of governance not only contains complex and integrated technology but also includes the “double-edged sword” effect in its innovation and development.

On one side, dependency on technology systems makes the development of big model governance can force antecedent technology’s innovation and development through multiple intermediate technology procedures, and advance the invention and innovation of complementary technology industry [1047,1048]. First, China is a big data country with abundant data resources, but the existing high-quality data sets only account for a small proportion. Therefore, the development of the big model can promote the construction of high-quality data sets. Second, the big model’s development can contribute to the innovation of the underlying hardware and chips, and Computer System Architecture. In addition, the enlargement of big models can support a lot of downstream scenarios, such as automation, smart health care, smart cities, and other intelligent applications in society. It also plays a significant role in industrial collaboration and technological proliferation.

On the other side, as an important GPT, the technological uncertainties and risks of the big model and its development will be amplified with the deepening of technology and the expansion of the technical social system [1049, 1050,1051]. Due to the big model being the “operating system” of the AI ecology, therefore, the security, reliability, stability, fairness, and algorithm bias of it will also be influenced by the development and application of big models.

---

All authors of Section 12 contribute equally. The authors are alphabetically sorted

### 12.1.3 The Objectives of Big Model Governance

Due to the big model governance is the process to achieve multiple governance goals, thus, the main ambition of it is to balance development and security. Development and security mutually rely on each other. On one hand, development is a prerequisite for security. On the other hand, security is the guarantee for development. Therefore, as the ecological core of the Future AI, big model governance should insist on the development concept and governance goal of *AI FOR GOOD*. Meanwhile, considering some specific governance scenarios and fields, the goal of big model governance should include architectural innovation to promote the development of the main parts of big models. The goal also needs to ensure the security of the big model's underlying data, the interpretation and fairness of algorithms, and the robustness and accountability of the model.

**AI FOR GOOD.** *AI FOR GOOD* is not only the core concept of AI development and governance but also is the primary concept of big model governance. According to the classification of “good” by Plato, “Big Model Governance for Good” means that the big model incorporates public-order algorithms into itself to make the big model governance human-centered, human-friendly, and trustworthy. Additionally, the innovation and application of the big model should contribute to the sustainable development of human society [1052,1053,1054]. What's more, the goal “Big Model Governance for Good” aims to explore the potential of big model's technology. Meanwhile, it needs to deeply analyze the boundary and limitations of its application, and prevent the loss of human value.

**Security.** There are three dimensions of the security (at data level) goal of big model governance: data security, data autonomy, and macro security of data. Data security refers to ensuring the confidentiality, integrity, and availability of data through identity authentication, access control, data encryption, security management, and other technological measurements and necessary security system. Data autonomy means that the state has the dominant power on administering these below data through building data catalogs, taking risk assessments, promoting data localization, and measuring the cross-border transfer of data and information to avoid other organizations or states to illegal manipulating, surveillance, stealing, and interfering these data<sup>4,5</sup>.

- *Core Data* that relates to national security, national economy, people's livelihood, and significant public interests.
- *Important Data*, for example, if the data get tampered with, sabotaged, disclosed, or illegally acquired, it will cause serious harm to national security and public interest.

Macro security of data refers to the threats of national security, public interests, and organizations' legal rights and interests caused by the prevention and management of data processing activities.

**Interpretability.** Interpretability of big models is very acute in high-level risk decision scenarios, such as medical diagnostics, autonomous decision-making, smart finance, and smart justice [1055,1056]. For example, the financial sector is concerned about the lack of interpretability and auditability caused by the widespread use of some opaque models, e.g. deep learning, which might create some macro-level risks. The governance goal of interpretability aims to explain the verification and motivation of the big model's intelligent decision process, make the decision of the big model explainable, and then enable model users to understand and trust the decision. It also should let users have the right to interpret and challenge autonomous decisions. Besides, it should clarify the logic, importance, and consequences of the data processing procedures. More details can be found in Section 9.

**Fairness.** Fairness is to deal with things reasonably and without prejudice to any party [1053,1057,1058,1059,1060]. The key point to guarantee the fairness of big model governance is based on a few reasons. First, the absence of bias or favoritism toward individuals or groups due to their inherent or acquired attributes in the model's decision-making process. Second, the decision-making process can accurately identify the sources of model bias and try its best to eradicate or mitigate these biases. In addition, big model governance is able to reasonably choose the definition of fairness and adjust the decision-making process depending on different application scenarios and specific ethical norms, such as perceived fairness, statistical fairness [1061,1062,1063], or causal fairness [1064,1065,1066].

<sup>4</sup> The EU General Data Protection Regulation(GDPR), 2018.

<sup>5</sup> The Data Security Law of the People's Republic of China, 2021.

**Robustness.** Robustness indicates that the stability of big model system can deliver failure-free services [1067,1068,1069,1070,1071,1072,1073,1074], which mainly contains two aspects: the reliability of its internal module and its system coupling, and the generalization ability of big model system for untested data. Therefore, the goal of big model governance’s reliability aims to identify the potential problems in its system, scientifically assess the generalization ability of big models, pursue process management, technology migration, and model representation effectively, and guarantee each stakeholder can afford the stable operation level of the model.

**Accountability.** Accountability signifies that the controllability of the big model, the implementation of responsible technological innovation, and the prevention of technological abuse [1075,1076]. The goal for the accountability of Big model governance lies in designing and constructing appropriate innovation mechanisms to achieve the responsibility of the model’s research and development (R&D) and innovation. It also attaches great importance to the legitimacy, inclusiveness, and public sentiment of big models’ innovation when focusing on playing the positive role of the innovation of big models. In addition, the accountability suggests that when ensuring the freedom of big model’s R&D and innovation, it should also guide the big model’s development to benefit the sustainability of economic and social development and promote the long-term development of the Community of Shared Future for Mankind. Which intends to avoid misuse and abuse of big models and then finally realizes the autonomy, controllability, and accountability of big models.

## 12.2 Overviewing and Analyzing Existing Works

### 12.2.1 Security

While the BM can obtain stronger performance with powerful generalization ability, they have also been demonstrated to have *unintended memorization* issue [1077], which refers to the phenomenon that a model remembers some individual examples, e.g., a phone number, home address, or a credit card number. This issue could cause serious privacy risks in case the training data of the model contains confidential user information. Several recent studies have shown that the training data of the opened pretrained model (e.g., GPT-2) can be extracted even using free-form generation [1077, 1078, 42, 1079, 1080, 1081]. Besides data reconstruction attacks, membership inference attacks (MIA)[1082], as indirect leakage, are also potential threats faced by large pretrained models [1083, 1084, 1085, 1086]. OpenAI’s recently released CLIP image encoder has been demonstrated to be very vulnerable to MIA[1085]. Recent studies have also shown that the adversaries can steal sensitive information from the model only using the embeddings of words or nodes [1083, 1084]. Besides, information leakage in pretrained models, recent works show that the adversaries can also successfully execute privacy attacks during the finetuning stage via the differences between the pretrained model and the finetuned model [1087, 1088].

In addition to privacy attacks on **data confidentiality**, the **integrity** of model is also vulnerable to the attacks like data poisoning attacks [995, 1037, 1089, 1090, 1091] and adversarial attacks [862, 786, 463]. So far, the successful BM (e.g., BERT and GPT-3) are usually trained using large unlabeled datasets crawled from the Web. Such a permissive data collection paradigm makes it very easy to inject poisoning data. Recent studies demonstrated adding a few specially-crafted data to the training corpus can manipulate the model, e.g., generating offensive text [1092, 1016], wrong translations [1093] or suggesting insecure code [1090]. Moreover, the backdoors in the pretrained language models can impact a wide range of downstream tasks [1035]. It makes the pretrained model a single point of failure for all downstream applications.

### 12.2.2 Interpretability

Machine learning beneficiaries not only want the model to make correct predictions, but also want to understand the decisions of the model, i.e. they want the model to be interpretable. However, with the increase of neural network architecture complexity and network depth, it is more difficult to understand the behavior of the model. In any case, to better govern models, interpretability research should not be slack.

Section 9 gives more detail of interpretability research.

### 12.2.3 Fairness

As AI models are increasingly being used in many societal contexts, there are growing concerns that significant bias may be introduced by these models with respect to certain sensitive attributes, e.g., against black people while predicting future criminals [1094, 1095, 1096], granting loans [1097] or NYPD stop-and-frisk [1098], and against women while



recommending jobs [55]. It is known that applying AI models to ordinary human-related decision-making tasks may lead to human-like semantic biases, such as computer vision [1099], audio processing [1100] and text corpora [1101, 1102]. Similar to any AI model, existing inequalities in big models may compound historical discrimination [1103], by producing unfair results, information cocoon, and disproportionately negative consequences to minorities [1104, 1105, 1106]. Since big models may affect downstream applications, understanding how biases produce in big models and their harms has attracted attention recently [1107, 20, 1108, 1109, 1110, 1111, 1112, 1113].

**Representation Bias.** Imbalanced distributions over sensitive groups may result in representation bias in big models, including misrepresentation, under-representation, and over-representation. Due to pernicious stereotypes [53, 1114, 1115, 1116] or negative attitudes [1117], people can be *misrepresented* in big models, which can be transferred to society through downstream applications [1118]. Minority groups can be *underrepresented* or excluded in training data [1119, 1120, 1104, 1121], which may affect the performances/utilities of minorities in the downstream models. People may also be *overrepresented* [1122, 1123], e.g., English is the only language to be studied prior to 2019 [1107], which can amplify majority voices and produce information cocoon. Representation bias is usually intrinsic to human language, and it is a challenge to recognize representation bias in big models, specifically when the protected attribute is not an explicit feature in the dataset, e.g., in some computer vision tasks.

**Label Bias.** Due to historical discrimination or pernicious stereotypes, people can be marked with imbalanced labels, and such bias may further reflect in big models. For instance, Brown et al. [20] reported that 83% of 388 occupations tested were more likely related to males by GPT-3, and higher educated professions (e.g., professor, banker) were also heavily related to males. Conversely, professions such as midwife, nurse, and housekeeper were heavily related to females. Both them and Abid et al. [1115] observed that Islam was associated at a higher rate as marks “violent” and “terrorism”. Users of downstream applications can experience specific harms due to label bias in big models, e.g., when GPT-3 is asked to complete a sentence containing the word “Muslim”, among more than 60% of cases the sentence is associated with shooting, bombs, murder or violence [20].

**Model Bias.** Except for data biases, big models may induce or increase disparities. For example, language models may induce poor performance in African American English [1124, 1121], have difficulties detecting the faces of people with darker skin tones [1104], or incorrectly detect medical conditions concerning racial or gender minority groups [1125]. It is also known that computer vision technologies provide uneven benefits and risks distributed across society, introducing harms on marginalized communities [1126, 1105, 1127]. Such model bias implies that corresponding (sub)-groups may not benefit from downstream applications and may have disadvantages in competition (e.g., work opportunity). Also, it is observed that big models may amplify training data biases [1128, 1129, 1130]. Investigations on what and how this bias amplification happens are still unclear, which makes the task of debiasing harder.

**Modeler Bias.** As with other decision-making tasks, big models are developed and applied by stakeholders and marginalized communities, who may admit explicit/implicit bias. While it is difficult to document, the possibility of modeler bias has been verified. For instance, Caswell et al. [1131] investigated multilingual datasets and showed the flawed data handling of less-represented languages. Hutchinson et al. [1117] showed that models often contain undesirable biases towards disabled persons, which should be noticed earlier by modelers. It is interesting and important to build mechanisms for preventing modeler bias. One step is to increase the diversity of modelers or responsibility planning [21], and further investigation is on road.

As big models have been applied increasingly and have recently demonstrated significant performance gains, debiasing has also attracted a lot of attention due to multiple reasonings of bias. However, developing debiasing frameworks for big models has suffered difficulties, mainly on how to measure bias and mitigate bias. Depending on the types of big models, people design different measurements of bias accordingly. For mitigating bias, there are three commonly used methods: preprocessing, inprocessing, and postprocessing [1132]. Preprocessing techniques transform the data so that the underlying discrimination is removed. In-processing techniques try to modify the learning frameworks in order to remove discrimination during the model training process. After training, post-processing is performed by fine-tuning the model to fit specific fairness criteria. We discuss language models and computation vision in the following, and show their corresponding progress.

**Debiasing in Language Models.** In the field of deep natural language models (e.g., BERT and GPT-3), we usually train on large datasets from the Internet and may encode biased knowledge to word embeddings. Earlier work on

measuring bias of language models was demonstrated on word embeddings [53,1114,1133,1134]. Specifically, Caliskan et al. [1114] proposed a standard bias measurement on the associations word embeddings, called the Word Embedding Association Test (WEAT), inspired by the Implicit Association Test (IAT) [1135]. However, even if the social bias is eliminated at the word level, the sentence-level bias can still exist due to the imbalanced combination of words. Recently, there have been several studies on how to measure sentence-level bias [1136,1137,1109]. Moreover, Xu et al. [1111] showed that detoxification techniques, which are useful in language models, may hurt equity.

There are several ways to mitigate bias in language models. Referring to preprocessing, we can do bias subspace subtraction [1138,1139,1140], or data augmentation [1141,1142,1143,1108] by e.g., replacing sensitive words in the original sentence with words in a similar semantic but different bias directions. Considering inprocessing, we may re-train the models with additional fairness constraints or introduce adversarial training [1128,1144,1130,1145]. For post-processing, transfer learning [1146] is an option, e.g., fine-tuned language models on English to address its efficacy on Chinese as well.

**Debiasing in Computation Vision.** Existing fairness metrics are usually defined for a certain sensitive attribute, e.g., sex or race. In computation vision, sensitive features are usually implicitly represented by graphs or videos and can even be entangled with each other, but big models may still induce prediction bias [1147,1148]. Due to the large input dimension, finding the sensitive features are challenging [1148]. Compared with traditional machine learning, a big model is more complex to interpret and may end up being tried to harmful assumptions and stereotypes, making it more difficult to measure the model’s dependence on sensitive features and reduce bias. To handle this difficulty, several prior works show how to measure bias for multiple tasks in computation vision [1104,1149,1150,1151,1152,1153,1154], including data bias and model bias. For instance, Wilson et al. [1151] showed how pedestrian detection systems display higher error rates with people with darker skin tones. In another study [1155], researchers investigated the generation of gender-specific caption words (e.g., man, woman) based on the person’s appearance or the image context. They found a significant correlation between men and sports equipment. Besides measurement, debiasing seems more difficult due to the complicated sources of bias and the incomplete understanding of big models. By applying an intersectional approach, projects such as **Gender Shades** found that gender classification models perform with an accuracy of 99%-100% on white males but only with an accuracy of 65% on black females. Technically, it is still unknown whether we should label sensitive attributes explicitly, which makes Google switch off its AI vision service’s gender detection.

#### 12.2.4 Robustness

Robustness requires the generalization ability of a big model system for untested data, which is known as the out-of-distribution (OOD) generalization issue. Modern machine learning techniques have illustrated their excellent capabilities in many areas, including computer vision, natural language processing, and recommendation. While enjoying the human-surpassing performance in experimental conditions, many researchers have revealed the vulnerability of machine learning model when exposed to data with different distributions [1156]. According to [1156], approaches that deal with the OOD problem can be categorized into three parts, *i.e.*, unsupervised representation learning, supervised model learning, and optimization-based models.

**Unsupervised Representation Learning.** These methods utilize human’s prior knowledge to restrict the representation learning procedure, which endows the learned representation with certain properties that are potentially helpful for OOD generalization. Methods in this category can be further divided into two parts, including disentangled representation learning [1157,1158,1159,1160,1161,1162,1163] and causal representation learning [1164,1165,1166].

**Supervised Model Learning.** Compared with unsupervised methods, approaches in this category incorporate supervised information to design various model architectures and corresponding learning strategies. Typical approaches include domain generalization methods [1167,1168,1169,1170,1171,1172], causal & invariant learning [1173,1174,1175,1176,1177,1178], and stable learning [1179,1180,1181,1182,1183,1184,1185].

**Optimization-based Models.** These methods are both model agnostic and data structure agnostic. With strong theoretical guarantees, optimization-based methods have recently aroused much attention. These methods include distributionally robust optimization [1186,1187,1188,1189,1190] and invariant-based optimization [1191,1192,1193,1194] approaches.

### 12.2.5 Accountability

As a transformative technology and the increasing applications of Artificial Intelligence big models in medicine, education, transportation, defense, and many other areas, the accountability of big models has attracted wide attention from government, academia, industry, and various organizations [1195,1196,1197,1198]. Specifically, International Business Machines Corporation (IBM) have built their perspective on accountability of ethical AI model design, that is, AI designers and developers are responsible for considering AI design, development, decision processes, and outcomes [1199]. Organization for Economic Cooperation and Development (OECD) defines accountability similarly to IBM, while additional including the requirement of demonstration such responsibility through their actions and decision-making process, e.g., by providing documentation on key decisions throughout the AI model lifecycle or conducting or allowing auditing where justified [1200].

To help entities promote accountability of AI models, US. Government Accountability Office (GAO) proposes an AI accountability framework [1201], identifying key practices and principles four aspects, i.e., governance, data, performance, and monitoring. Specifically, *Governance* aims to promote accountability by establishing processes to manage, operate, and oversee implementation. *Data* devote to ensuring quality, reliability, and representativeness of data sources, and processing. *Performance* aims to produce results that are consistent with program objectives, while *Monitoring* hopes to ensure reliability and relevance over time. Although various organizations and academia have put forward their own definitions and frameworks for model accountability, there is still a long way to go before the real execution of accountability.

## 12.3 Open Problems and Future Directions

### 12.3.1 Big Model Governance System

Big model governance not only requires the active participation of government, R&D organizations of the big model, the users of big model, and other third-party organizations but also needs to comprise a wide range of technology stakeholders into the governance process. On the basis of establishing the value consensus of big model governance, stakeholders should sort out the value division of multiple participants in the big model governance, and then combine all collaborators' capabilities, and choose the appropriate governance methods and tools for themselves. Which finally form the cooperative and collaborative governance mechanism for big models.

First of all, stakeholders should develop a common understanding of the value of big model governance, which also is the foundation of cooperation and collaborative governance among these stakeholders. In addition, stakeholders should contemplate big model governance comprehensively and scientifically. Specifically, according to the Principles of Next-Generation AI Governance-Responsible AI<sup>6</sup>, big model governance should be guided by the basic governance principles of AI governance: ***Harmony and Friendliness, Fairness, Inclusiveness and Sharing, Respect for Privacy, Security and Controllability, Shared Responsibility, Open Collaboration, and Agile Governance***. Moreover, big model governance can improve coordination of the relationship between the development and governance of AI through mainly focusing on the value-oriented of inclusiveness, share, prudence, and accountability. Moreover, the holistic governance of the big model should find a balancing point among multiple objectives. This not only needs to promote the innovation of big model's technical system, particularly increasing the ability of technical innovation of the underlying software and hardware, but also should reduce energy consumption, advance the green development, promote high-quality development while guaranteeing the overall security of the big model.

Second, big model governance needs to insist on holistic governance while promoting modular governance. It should balance the relationship between development and regulation for each technology module. The objectives of data governance not only need to attach great importance to the governance of underlying data security, but also should pay attention to the openness of public data and moderate data flow to ensure the data to be used reasonably and promote the ecological development of the big model and artificial intelligence. In the aspect of computation power's governance, on the one hand, big model governance needs to explore the design and architecture of new chips. On the other hand, it needs to implement the concept of green development and reduce the energy consumption ratio of computing centers. In the field of algorithms' governance, big model governance should actively promote the innovation of algorithm transparency to clearly assist human beings to better control, modify, regulate, develop, and apply big models. Considering the technical generality of AI, stakeholders should promote digital transformation and upgrading of various sectors, particularly in industry. Besides, the big model should explore the complementary technical inventions, innovations, and infrastructure constructions due to the characteristics of generality and specialization.

What's more, in order to create synergy in big model governance, the stakeholders should play their multiple advantages respectively, meanwhile, taking into account the difference of governance capabilities and superiority's

<sup>6</sup> National Governance Committee of Next Generation Artificial Intelligence, the Ministry of Science and Technology, People's Republic of China, 2019.

among all stakeholders, and balancing the costs and efficiency of governance. The establishment of big model governance also needs to focus on related R&D and innovation institutions and form the dynamic and interactive collaborative governance mechanism. The demands of stakeholders involved in big model governance are not invariant due to the timely requirement of technological innovation and governance, methods of innovation governance, and governance tools. Therefore, the big model governance should maintain the thoughts of “Iterative Optimization”. Additionally, because of the existence of the “Black Box” effect, big model governance should adhere to the governance concept of exploratory and allow related R&D, innovations, and applications to be piloted in different fields under the premise of ensuring safety bottom line, so as to stimulate stakeholder’s innovation enthusiasm. Promoting of big model generation needs to exploratory use pre-design and governance, which indicates that the goal of governance should be involved in the design of the big model, and the norms of “ethic and value” should be designed integrated and synchronous during the AI innovation process and the design of AI’s research and development.

### 12.3.2 Security

To ensure user privacy in the pretrained models, one potential way is to delete those specific sensitive data from the trained models. In fact, the data protection legislation like GDPR and CCPA have already provided individuals with the *right to be forgotten*, which entitles individuals the right to delete their data from the learned models. Machine unlearning [1202,1203], also known as *selective forgetting* [1204] or *data removal/deletion* [1205,1206], offers a potential solution for this problem. It aims to remove the influence of a specified subset of training data upon request from a trained model. In this way, unlearning can also be used to defend against the attacks on model integrity with the ability to quickly eliminate the influence of the dirty samples [1022]. However, the efficiency for unlearning in a big pretrained model is still a big challenge and less studied. Besides, while originally designed to protect the privacy of the data owner, recent studies have shown that the unlearning self might also cause unintended privacy risks [1087, 1207]. Thus, how to safely remove sensitive data is still an open problem.

Differential privacy [1208] provides a powerful mathematic tool to protect data privacy in the growing trend of the sharing and publishing of pretrained models [1209,1210]. While originally proposed to preserve data privacy, it also conveys a degree of resistance to data poisoning attacks since a small number of injected samples can have only a limited impact on the resulting model [1211]. Thus, combining the power of differential privacy and the big pretrained models is becoming a promising direction [1212,1213,1214,1215,1216]. However, in practical usage, a large privacy budget  $\epsilon$  and relaxation  $\delta$  are always used to avoid large performance drops, along with incurring the risk of disclosure [1217,1218]. How to enjoy the benefits of differential privacy while keeping the utility of the pretrained model is a challenging open problem.

### 12.3.3 Fairness

A natural direction for future work is how to efficiently improve the quality of dataset representations by debiasing both distributions and labels. Although researchers have showed that data augmentation [1141,1142,1143,1108] or changing labeling scheme [1219,1220], their approaches make collecting procedures more expensive. Due to the expensive cost of data clean, there is growing interest in training accurate models in the presence of biased data [1221,1222]. However, such inprocessing schemes are still far from debiasing. It is interesting to investigate the combinations of debiasing on both datasets and models in the future.

Another direction is to automatically divide bias tolerance to different datasets. Perfect fairness metric with respect to a certain sensitive attribute may introduce loss on the model accuracy, and may even harm other attributes, called fairness gerrymandering [1223]. Kulshrestha [1224] takes an initial step to detect the best tolerance parameters. Deciding tolerance criteria can also guide modelers to develop or apply big models.

Regulations are an emerging challenge for big models considering fairness issues. The European Union is working on fair regulations. However, it is unknown exactly what such regulations will look like and affect society, making it difficult for researchers and companies to navigate. Due to society’s complexity, understanding different fairness measurements’ short/long efforts is not easy but essential to regulations.

### 12.3.4 Robustness

According to [1156], there exist several potential challenges that could be the directions of future research in this area.

**Theoretical Characterization.** The theoretical characterization of a robust (learnable OOD generalization) problem remains vague in recent literature. This problem is vital on the grounds that characterizing the learnability of a problem is a basic question in machine learning tasks. In robustness problems, it is important to answer what kind of distributional shifts or robustness should be taken into consideration.

**Demands for Environments.** The majority of existing methods require multiple training environments for robustness. However, modern datasets are often assembled by merging data from multiple sources without maintaining source labels. Therefore, it is more practical that we only have access to one training environment with latent data heterogeneity. As a result, how to explore and make good use of the latent heterogeneity is critical for the deployment of robust models.

**Reasonable Evaluations** Although the evaluation criteria under *i.i.d.* assumption are well developed, they cannot directly be deployed to robustness or OOD scenarios. Since the testing distribution is both unknown and different from the training distribution, how to design reasonable and realistic experimental settings remains a challenging problem.

### 12.3.5 Accountability

To ensure the real execution for big model accountability, one open problem and possible future direction is the *technical analysis and guarantee behind the proposed principle for accountability*. For example, if we want to assess the reliability, quality, representativeness of data used in big models, then it is critical to design technical and reasonable evaluation metrics for these characteristics of data. Similarly, if we want to identify potential biases, inequalities, and other societal concerns resulting from the big model, then the bias evaluation and fairness definition in mathematical formalization are also important research points.

Another important and open problem is that how accountability can be achieved in black-box big models? A promising direction for future research may be the explainable big models. How to design explainable big models relying on some state-of-the-art technologies such as causal learning? Or how to propose general explanations independent of the type of big models? Only by standing on the shoulders of the above research achievements can we truly realize the accountability of big models.

## 13 Big Model Evaluation

*Authors: Qingxiu Dong, Zhifang Sui <sup>✉</sup>, Shuai Zhao, Boxi Cao, Sha Yuan, Xianpei Han, Weidong Zhan, Baobao Chang*

With a large number of BMs being proposed, the evaluation of models obtains more significance. BM evaluation refers to the activity of evaluating the performance, efficiency, and other features of BMs. The evaluation task designing and aggregating, the evaluation dataset construction, as well as the evaluation metric selection are core issues of BM evaluation. Inappropriate tasks or metrics, biased datasets will result in unfair comparison and wrong trends, as BM evaluation has great guiding significance, manifested in the following three points:

- The BM evaluation result is an intuitive explanation. It displays the model’s ability or cost, reflecting the progress of deep learning at each stage;
- BM evaluation provides a direction for the development of models on various tasks and helps each sub-field to establish short-term and long-term optimization goals;
- The evaluation makes the capabilities of the BMs intuitive and comparable, inspires researchers to participate more in related directions, and dramatically promotes the development of model pre-training.

Therefore, any problem or deviation can seriously affect the fairness and objectivity of the evaluation. In the longer term, it will even hinder the iterative progress of models and algorithms, resulting in the deviation of research and development. In this part, we intend to introduce model evaluation from following aspects.

- In Section 13.1, we summarize existing benchmarks and corresponding datasets, including both the performance evaluation and the efficiency evaluation.
- In Section 13.2 and 13.3, we analyze the problems of the existing evaluation combined with previous research for performance evaluation and efficiency evaluation respectively.
- In Section 13.4 and 13.5, we put forward solutions and suggestions for evaluating the future and the training model in a targeted manner.

### 13.1 Existing Benchmarks and Corresponding Datasets

As crucial issues of BM evaluation, benchmarks and datasets play a significant role in the outcome results. This section introduces mainstream existing benchmarks and tasks (datasets) for BM evaluation.

---

Zhifang Sui (szf@pku.edu.cn) is the corresponding author of Section 13.

### 13.1.1 Benchmarks on Model Performance

Most evaluation datasets and benchmarks focus on the performance of BMs. If a single task-specific dataset aims to evaluate the model performance, it can be seen as an evaluation benchmark naturally [387, 842]. While there is a large amount of such single-dataset benchmarks, we can not list them all. Here we focus on comprehensive benchmarks, which aggregate and re-organize several single-datasets for a general evaluation.

#### 1. NLP

Salesforce proposed *DecaNLP* [540] in 2018, aiming to unify various NLP tasks with a question and answer framework. The evaluation includes public datasets corresponding to 10 tasks. The data samples are uniformly converted into triples of the question, context, and answer. In 2019, institutions like New York University and University of Washington proposed *GLUE* [291]. It is an English natural language understanding (NLU) benchmark and analysis platform. It is a collection of nine language understanding tasks. However, due to the emergence of BMs such as BERT, the GLUE benchmark has become weak in evaluating large models and gradually reached the upper limit. As a result, researchers decided to upgrade it to *SuperGLUE* [1225]. It retains two GLUE tasks and also introduces five more difficult tasks. Correspondingly, similar benchmarks in other languages are gradually built, such as CLUE and LUGE for Chinese.

To evaluate BMs under a unified standard, CMU, Google Research, and DeepMind proposed a large-scale multi-language multi-task benchmark *XTREME* [1226] covering forty languages. The benchmark covers 40 different languages and contains 9 tasks that require reasoning on different syntactic or semantic levels, achieving language diversity, coverage of existing tasks, and availability of training data maximize. Coincidentally, in May 2020, Microsoft released the *XGLUE* [1227] benchmark, which is used to evaluate the performance of cross-language BMs. It consists of 11 tasks and covers 19 languages.

Besides the benchmarks mainly designed for model performance on classification, benchmarks like *GLGE* [1228] focus on model performance on generation. Sichuan University and Microsoft proposed GLGE in November 2020, containing 8 English generation tasks. To reflect performance on various difficulty levels, They designed GLGE into three categories: GLGE-easy, GLGE-medium, and GLGE-difficult according to the difficulty. However, GLGE-medium and GLGE-difficulties are obtained directly by screening training data, and the design of difficulty grading is still relatively limited.

To better benchmark general-purpose language intelligence, Beijing Academy of Artificial Intelligence proposed *CUGE*, a Chinese Language Understanding and Generation Evaluation benchmark with a hierarchical benchmark framework and multi-level scoring strategy. CUGE selects and organizes datasets in a language capability-task-dataset hierarchical framework, covering 7 important language capabilities, 17 mainstream NLP tasks, and 19 representative datasets. The framework is carefully designed according to the human language examination syllabus and the current research status.

#### 2. Multimodality

The fusion and interaction of multiple modalities is a key research direction of large models. Since there is no comprehensive benchmark on multimodality, we will introduce some widely-used task-specific datasets, which actually act as benchmarks for multimodality evaluation.

*VQA* is a common multimodal evaluation task. It always contains open-ended questions about images. These questions require an understanding of vision, language, and commonsense knowledge to answer. The VQA datasets include DAQUAR [708], Visual Genome [709], MSCOCO-QA [710], VQA [711], etc. *GQA* (Grounding Question Answering) is similar to VQA, except that GQA tests the reasoning capability of the model to answer a question. GQA is a new image scene graph question and answer dataset proposed in 2019 [712]. It consists of 22M questions, including various images from MSCOCO and Flickr.

*VCR* (Visual Commonsense Reasoning) is regarded as one of the most authoritative rankings in the field of multimodal understanding [712]. Generally, it requires the model to recognize the attributes and relationships of the characters in the figure and further infer the intentions of the characters on this basis. The VCR is a large-scale dataset for visual commonsense reasoning, including about 290K question, answer, and explanation pairs, covering more than 110K non-repetitive movie scenes. VCR contains two sub-tasks: visual question answering ( $Q \rightarrow A$ ) and answer justification ( $QA \rightarrow R$ ), both multiple-choice problems [702]. The holistic setting ( $Q \rightarrow AR$ ) requires both the chosen answer and chosen rationale to be correct.

*RE* (Referring Expressions) gives a natural language description and locates the relevant area in the image. This task involves fine-grained cross-modal semantic alignment. Therefore, it is more important to examine the fineness of the semantic description of the joint representation. Generally, it contains three referring expression datasets based on the MSCOCO dataset [715]: RefCOCO, RefCOCO+, and RefCOCOg. *IR&TR* (Image Retrieval, Text Retrieval) is a classic task in the multimodal field. There are two sub-tasks: image retrieval and text retrieval, depending on which

modality is used as the retrieved target. This task is essentially to calculate the semantic similarity between image modalities and text modalities, requiring the model to consider both general semantics and fine-grained semantics. MSCOCO and Flickr30K [714] are two regular data sets for multimodal retrieval tasks.

*IC* (Image Captioning) Different from the previous evaluation tasks, IC is a generation task. The model needs to generate a natural language description of a given image. Generally, to enable the BM sentence generation downstream task, the model needs to be followed by a seq2seq or other generation module. Furthermore, experiments always took on MSCOCO captioning dataset. It should be noted that, unlike the previous evaluation indicators, BLEU [720], METEOR [721], CIDEr-D [722], SPICE [723] are often used as metrics of the next-generation quality.

*NoCaps* (Novel Object Captioning) points that image captioning tasks need amounts of paired image-text training data, while unlikely to be obtained in some specific tasks [724]. So, it aims to evaluate whether the model can accurately describe the newly appeared categories of objects in the test image without corresponding training data. *NLVR2* (Natural Language Visual Reasoning for Real), initiated by Facebook ParLAI Research Award, contains 107,292 examples of human-written sentences grounded in pairs of photographs [713]. It takes a pair of images and a natural language as inputs. The goal is to determine whether the natural language statement is true about the image pair. Accuracy is the only evaluation index.

### 13.1.2 Benchmarks on Model Efficiency

For large models, performance and efficiency are both crucial. However, in terms of large model evaluation, most benchmarks only focused on the performance and ignored the efficiency. Existing comprehensive benchmarks for model efficiency are also very limited. To this end, Fudan University and Huawei Poisson Lab proposed *ELUE* [1229], a benchmark for efficient NLP models. ELUE evaluates not only models' performance, but also their efficiency using FLOPs and the number of parameters as metric. It covers 6 datasets of 4 tasks, including sentiment analysis, natural language inference, similarity, and paraphrasing.

## 13.2 Challenges of Performance Evaluation

**Unconstrained Proposals** Due to the lack of fundamental principles or requirements for evaluation, proposing individual performance evaluation is often simplified to proposing a new dataset, while comprehensive performance evaluation is mostly a simple aggregation of individual performance evaluation data. Therefore, the entry barrier for big model evaluation is low at the moment, which leads to the enormous amount and uneven quality of existing evaluations.

**Ineffective Evaluation Tasks** Faced with models with increasingly large parameters, it is difficult for most evaluations to clearly distinguish the performance of BMs and humans on the test set through traditional metrics and a single ranking list. Specifically, shortly after the introduction of an evaluation task, the score of the BMs has often approached or even surpassed the human score. As it shown in Fig. 25, in recent years, the development and progress of the BMs have been very rapid. Such evaluation tasks lacked challenge and vitality.

**Biased Datasets** In 2019, researchers [1230] found that BERT's performance in multiple evaluations may vary only due to some false relevant statistical clues, such as the words "no" or "yes". This demonstrates that irrelevant clue bias is misleading for the evaluation of BM performance. In this case, the effectiveness and reliability of the evaluation itself are significantly reduced.

In addition, other researchers [849] found that the process of crowdsourcing labeling may also introduce relevant clue bias. When writing natural language data (such as generating questions or hypotheses), the habit or subconsciousness of crowdsourced annotators' vocabulary can also lead to biases in these association clues.

Recently, some semantic work shows that the multimodal cannot understand images and text well. For example, [1231] found that the dataset shows that the VQA model is invalid for new images after a series of studies based on the VQAv1. They can only understand the question but cannot change the answer in time when the image changes. In addition, the evaluation method of VQA is also debatable. The big model usually tries to solve it as a multi-label classification task, finding the highest probability among the predefined answer set, which is distinct from various VQA datasets.

**Controversial Metrics** The choice of evaluation metrics highly depends on the category of task. The evaluation metrics of classification tasks are relatively uniform and clear. However, the lack of such a recognized evaluation metric in NLG is often prone to distortion of the evaluation metric, which cannot truly reflect the capabilities of the BMs. The main

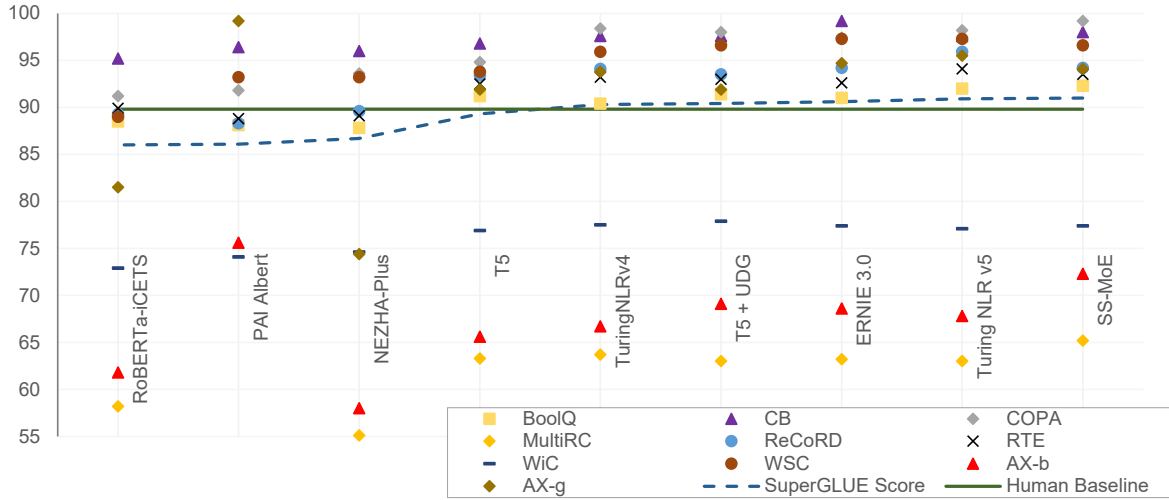

Fig. 25. Comparison between model performance and human baseline on SuperGLUE Benchmark.

ways to evaluate generation systems are manual evaluation and automated evaluation. Although manual evaluation is accurate, most tasks are very labor-intensive. Automated ones such as BLEU and ROUGE can evaluate the BMs easily, but they only measure the similarity between the generated text and the reference answer based on N-gram overlap. These metrics are only sensitive to changes in vocabulary rather than in sentence semantics or grammar.

Currently commonly used automatic evaluation indicators for image captioning tasks include BLEU, METEOR [721], CIDEr-D [722], SPICE [723], etc. [1232] conducted detailed research on the correlation of the indicators with human judgments. As a result, the highest METEOR score correlation with human is only 0.524. Therefore, these indicators cannot fully measure the quality of the modal generated description. In addition, [14] also found that indicators of multimodal on some datasets had reached or even surpassed humans. When they supplemented human subjective judgments, the inviters need to score the results generated by the model with four ratings (whether the image is described without any errors, described with minor errors, with a somewhat related description, or with an unrelated description). The result shows that BLEU@4 surpassed humans in the MSCOCO dataset but still does not capture the difference between network generation and human descriptions.

Therefore, they have been proved to be far from manual evaluation results repeatedly. The improper use of such evaluation metrics or the inconsistent metrics is also core issues that have been exposed in the current BM evaluation and have not been fully resolved.

**Unsystematic Aggregation** Although multi-task evaluations such as GLUE and CLUE claim general-purpose BM evaluations, trying to examine the NLU and processing capabilities of the model comprehensively, they are not complete, comprehensive, and systematic. Each evaluation task is separate, and it can only reflect the results on a particular task in a macroscopic view. The so-called comprehensive evaluation is not “comprehensive”, but simple data aggregation.

### 13.3 Challenges of Efficiency Evaluation

#### 13.3.1 Inadequate Metric

Currently, three metrics are commonly used to assess model efficiency but all with inherent limitations: 1) *FLOPs*, i.e., floating-point operations per second. In machine learning, FLOPs are often used to describe the number of operations required to run a single instance of a given model, which are indicators of the model efficiency. However, since other factors (e.g., parallelism degree) could also affect the running time, FLOPs only cannot fully represent the actual inference time. 2) *Model Size*, including the number of parameters, executed layers, etc., which could also affect models’ computational cost and inference speed, and therefore reflect the model efficiency. However, two models with the same model size but different architectures could significantly diverge in model efficiency (e.g., LSTM v.s. Transformers). Consequently, only using model size to assess model efficiency may be inadequate; 3) *Actual Inference Time*, which is the most intuitive metric for efficiency evaluation. However, since the actual inference time is heavily related to



both hardware environment and software implementation, and some algorithms may be hardware-specialized, it is challenging to make a fair comparison between models run on different infrastructures [1233]. In these cases, it is critical to propose new metrics which could comprehensively and faithfully assess model efficiency.

### 13.3.2 Non-standard Comparison

Currently, different studies often adopt different metrics. However, as we mentioned above, all current metrics such as FLOPs, model size, and actual inference time cannot comprehensively assess the model efficiency, combined with the various local infrastructures, which might lead to inconsistent, unfair, and unreliable evaluations.

### 13.3.3 Incomprehensive Benchmark

With the growing scale and computational expense of big models, efficiency has become another critical measurement besides accuracy when assessing big models for real-world application. Unfortunately, currently most mainstream benchmarks such as GLUE focus on accuracy more than efficiency. The lack of corresponding standard benchmarks may stall the progress of model acceleration and compression, and transferring models to new tasks and applying them in practical systems. ELUE is a promising attempt but still lacks coverage of metrics, tasks, and datasets.

## 13.4 Future Work on Performance Evaluation

Faced with the current status and problems of BM evaluation, there is much room for further improvement. We will introduce the directions and suggestions on large model evaluation for further future in this section.

### 13.4.1 Systematic Evaluation Outlines

Based on the requirements of the interpretability principle and the comprehensive principle, the evaluation of human-like BM ability needs to be carried out under systematic organization and guidance. Therefore, it is necessary to establish an evaluation outline in advance, systematically sort out the relevance and organicity between the various core technologies of NLP and various evaluation tasks, establish a relatively straightforward correspondence between BM ability and human language ability, and comprehensively count the current NLP items. The technological process. The evaluation outline can effectively standardize and guide future evaluations, and avoid chaos such as too many evaluations, uneven quality, and poor interpretability.

### 13.4.2 High Quality Datasets

We propose to evaluate the quality of natural language processing datasets in terms of reliability, validity, and difficulty with human test evaluation methods, and develop nine evaluation guidelines (Table 13) for human-like machine language proficiency evaluation datasets to guide the construction of future large-scale BM evaluation datasets.

**Reliability** Reliability measures the reliability of the evaluation dataset, including the three basic principles of normality, accuracy, and consistency. It is an essential guarantee to ensure that the evaluation dataset is reasonable and reliable.

- *Normality* The dataset should be equipped with clear records of data acquisition and transformations, etc. Also, datasets need to be effective in avoiding vacant values and formatting errors without data leakage problems.
- *Accuracy* The dataset annotation should be accurate, consistent with the annotation principles and schemes developed prior to the implementation of the annotation work, and ensure that the dataset does not include mislabeled examples as much as possible.
- *Consistency* On the one hand, the consistency of annotation among annotators should be measured by quantitative indicators, such as the kappa coefficient. On the other hand, the annotation of similar annotation objects should be consistent before and after. For example, in the Chinese word segmentation datasets, the annotation of partitive words should be consistent before and after the identification criteria.

**Validity** This indicator measures the validity of the assessment data set, including the three basic principles of balance, fitness, and unbiasedness. It is essential to reflect the testing purpose of the assessment task effectively.

- *Balance* The distribution of different labeling tags, types, or answers in the evaluation data set is balanced. For example, machine reading comprehension requires temporal, spatial, or retelling abilities and cannot test only one of these abilities.
- *Fitness* The data sample can effectively demonstrate the competencies necessary for the task, data providers are required to argue for their task validity in conjunction with random samples and provide argumentation data.
- *Unbiasedness* The dataset overcomes the bias factor brought by the habitual factor in the manual labeling process. Also, it circumvents the bias problem of the receipts themselves through appropriate data selection methods.

**Difficulty** The dimension states that the difficulty of the evaluation dataset needs to be measured, including three basic principles of differentiation, quantification, and challenge, and is a reflection of how well an evaluation dataset differentiates between different models and humans.

- *Differentiation* There should be some differentiation in difficulty between datasets of the same type of task. The assessment dataset should have strong discrimination between the abilities of the individual models at the moment, and the dispersion coefficient of all model results on the leaderboard should be large enough. The evaluation dataset should be sufficiently discriminative of human ability.
- *Quantification* Evaluating the quality of a dataset requires more in-depth quantification, with clear calculation criteria and formulas for measuring the difficulty of different data dimensions.
- *Challenge* The dataset needs to be challenging enough to fill the gap between the machine model and the human benchmark; the difficulty needs to be in the realm of what current machine capabilities can reach.

**Table 13.** Nine evaluation guidelines for human-like machine language proficiency evaluation datasets.

Dimensions	Guidelines	Main Principles
Reliability	Normality Accuracy Consistency	clear records, avoiding vacant values and formatting errors accurate annotation, consistent with the annotation principles, few mislabeled examples quantitative indicators, consistent annotation of similar objects
Validity	Balance Fitness Unbiasedness	balanced distribution of different labels the competencies be necessary for the task overcomes the bias factor, appropriate data selection
Difficulty	Differentiation Qualification Challenge	differentiation in difficulty, large dispersion, be discriminative of human ability in-depth quantification, clear calculation criteria and formulas be challenging but the difficulty be reachable.

### 13.4.3 Innovative Evaluation Approaches

**Modular Evaluation** We propose evaluation modularization for the evaluation organization in the future. Modular evaluation takes a particular type of labeled data as a component of the evaluation framework. For example, take a group of unlabeled news domain data as a first-level component  $A_1$ , label the named entity of data as a second-level component  $B_1$ , and label the summarization result as a second-level component  $B_2$ . Images related are also used as a secondary part  $B_3$ .  $A_1 + B_2$  can be used as a text summarization task, and  $A_1 + B_2 + B_3$  can be used as a cross-modal summarization task. This modular evaluation organization model improves the data reusing, and improves the interpretability and comprehensiveness of the evaluation at the same time. It realizes the separation of additional feature annotation information and the BM itself, promoting fair comparison of model performance.

**Interactive Evaluation** In the human interview process, the interviewer may provide information step by step to guide the interviewer for better answers. The interviewer and the interviewer are in a dynamic interaction state during the whole process. Drawing on this idea, the evaluation of BM performance can also be designed as a dynamic and interactive evaluation, guiding the BM to think from different angles and giving target information step by step.

**Dynamically Evaluation** A significant reason for the short life cycle of many BM evaluations is the common practice of fixed test sets. Although the model cannot see the test set data during the training phase, the continuous iterative comparison process of the model directly refers to the results on the test set. From a long-term perspective, the test set is used in the form of a “soft development set”. In this case, the performance of the BMs on the test set will naturally improve at a faster rate, which indirectly leads to the weakening of the vitality of the evaluation itself. To alleviate this situation and enhance the vitality of BM performance evaluation, technologies such as data augmentation and adversarial attacks can be used to introduce randomly changed test sets during the evaluation process.

**Adaptation Evaluation** Future work should propose more challenges for big models, and a crucial aspect is adaptation evaluation. In other words, take the performance under out-of-domain, few-shot, or zero-shot settings into consideration. Classical model performance evaluation often takes the model’s results on the test set with the same distribution as the training set, which leads to a huge gap in the actual application scenario of the model. In the future, more work can be focused on various scenarios. Besides relying on test scenarios and real environments in the industry, researchers can establish application-testing evaluations, using the model’s performance on natural scenes as evaluation results or as auxiliary information to provide references for evaluation results.

#### 13.4.4 Integrated Evaluation Platforms

As mentioned above, BM performance evaluation can be built into a general platform. For future work, the model diagnosis probing tasks can be included. We can generate interpretable evaluation results and fine-grained diagnosis reports automatically. We look forward to establishing a universal integrated evaluation platform in the future, organizing universal, interactive, and interpretable evaluation and diagnosis services. Furthermore, it is expected to provide efficient, accurate, and comprehensive feedback for the research and exploration of BM performance.

### 13.5 Future Work on Efficiency Evaluation

#### 13.5.1 Comprehensive Efficiency Benchmark

As we mentioned in Section 13.3, the lack of comprehensive benchmarks, as well as systematic comparison metrics, could significantly stall big models’ progress. Therefore, it is critical to design accurate, robust, and reliable efficiency metrics and create large-scale standard and comprehensive efficiency benchmarks for model training and inference.

#### 13.5.2 Standard Efficiency Checklist

Furthermore, we need to design a standard checklist for efficiency evaluation and encourage all researchers to report comprehensive experimental configurations such as local infrastructures, model architectures, model size, FLOPs, training, and inference time in each experiment for a fair comparison.

#### 13.5.3 Link to Social Good

As the enormous models are wildly applied to real-world applications, these models’ computational cost and environmental impacts could also be tremendous. Therefore, besides the models’ intrinsic efficiency evaluations, we also need to consider how to measure the energy cost and potential environmental impacts of models and encourage researchers to report the related metrics such as carbon emission.

## 14 Application in Machine Translation

*Authors: Zhixing Tan<sup>\*</sup>, Mingxuan Wang<sup>\*</sup>, Shuo Wang<sup>\*</sup>, Long Zhou<sup>\*</sup>, Jiajun Zhang<sup>✉</sup>, Yang Liu<sup>✉</sup>*

---

Zhixing Tan, Mingxuan Wang, Shuo Wang and Long Zhou contribute equally.

Jiajun Zhang (jjzhang@nlpr.ia.ac.cn) and Yang Liu (liuyang2011@tsinghua.edu.cn) are the corresponding authors of Section 14.

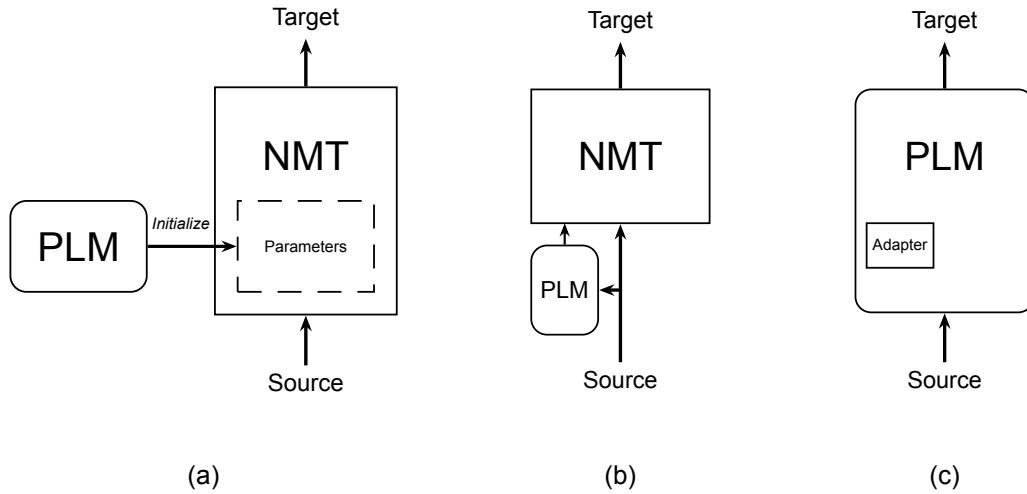

**Fig. 26.** Three typical approaches for utilizing monolingual pre-trained language models for MT. (a) Fine-tuning methods. (b) Component-based methods. (c) Adapter-based methods.

## 14.1 Background

Machine translation (MT) is a technology that leverages computers to translate human languages automatically. Since the MT concept was formally proposed in 1949 by Warren Weaver, more than 70 years of history have witnessed the rapid development of MT technology.

Before 2000, rule-based methods relying on handcraft rules were a dominant paradigm for machine translation. Thanks to the availability of large-scale human-translated parallel corpora in some language pairs (e.g., Chinese-English) and rich computing resources, the data-driven paradigm has dominated the MT community since the early 2000s. Statistical machine translation (SMT) is first proposed. Word or phrase level translation rules can be automatically learned from parallel corpora with probabilistic models, leading to better translation performance and good online translation service. However, due to complicated modeling, statistical methods cannot make full use of large-scale parallel data, and translation quality is far from satisfactory. Since 2013, neural machine translation (NMT), which models direct mapping between source and target languages in an end-to-end manner with deep neural networks, has achieved a big breakthrough and achieved remarkable improvements compared to SMT, and even approached human-level translation quality in some specific scenarios.

It is worth noting that the success of data-driven MT methods heavily depends on large-scale and high-quality parallel resources. In contrast, rich bitexts are only available in a handful of language pairs such as Chinese-English and French-English, while nearly 99% of existing thousands of human languages are low-resource languages. Even in the resource-rich language pairs, the parallel data are quite unbalanced because the bitexts mainly exist in several domains (e.g., news and patents). That is to say, the lack of a parallel training corpus is very common in most languages and domains. As a result, making full use of non-parallel data is a big challenge in machine translation. One popular solution is data augmentation that constructs pseudo parallel data using monolingual data through back-translation, forward-translation, and other semi-supervised approaches. In conclusion, this kind of method can boost translation quality in low-resource scenarios but would take a long time for pseudo data construction and may not be ideal.

In recent years, big models such as BERT and GPT are proved to be super powerful in utilizing massive unlabeled monolingual texts and achieve state-of-art performance in many natural language understanding and generation tasks. MT researchers have also investigated the big models to figure out the best solution to take full advantage of unlabeled data in neural machine translation. For one hand, various kinds of big models, such as BERT, GPT, MASS, XLM, BART, T5, and mRASP, are explored elaborately in MT. On the other hand, different kinds of machine translation tasks are studied to find the most suitable scenario for BMs. In the remainder of this chapter, we will introduce the mainstream applications of various BMs in different machine translation tasks.

## 14.2 Applications of Big Model in Machine Translation

### 14.2.1 Monolingual Pre-training for MT

The last three decades have witnessed the tremendous success of data-driven MT approaches, such as Statistical Machine Translation (SMT) [1234, 1235] and Neural Machine Translation (NMT) [4, 418, 25]. Data-driven MT approaches

aim to learn a translation model from parallel corpora, avoiding the need for hand-crafted translation rules. Besides parallel corpora, monolingual corpora are also essential resources for data-driven MT approaches. On the one hand, parallel corpora are usually limited in quantity, quality, and coverage [1236], which hinders the applicability of data-driven MT approaches. On the other hand, monolingual corpora, which have proven to be helpful in improving the fluency of translations [1234, 1237], are abundant in amount and easy to obtain. As a result, exploiting monolingual corpora have become an active research direction in the MT community [1234, 1238, 1237, 1236, 1239].

Pre-training, which aims to learn an expressive representation of an input sentence by reconstructing the input from a partially or corrupted version of it [26, 18, 1240, 289], is a powerful approach for making use of abundant monolingual corpora [26, 18, 48, 289]. Depending on the number of languages covered by the monolingual corpora, pre-training can be divided into monolingual pre-training and multilingual pre-training. Monolingual pre-training typically trains a large neural model on large monolingual corpora that mainly cover one language, with BERT [18], GPT-2 [26], MASS [1240], BART [289], and T5 [19] as salient examples. By providing context-aware representations of inputs or transferring knowledge to task-specific models through initialization and fine-tuning, these BMs have demonstrated their effectiveness on various natural language processing tasks [26, 18, 48, 289].

However, it is challenging to utilize monolingual pre-training for MT, as the objectives of monolingual pre-training and machine translation differ significantly [1241]. Machine translation is a bilingual task that requires equivalent transformation between two languages, whereas monolingual pre-training only aims to recover information from an input of one language. This discrepancy makes directly using monolingual BMs to perform translation tasks infeasible, and fine-tuning a BM using parallel corpora may suffer from severe catastrophic forgetting problem [1242, 1243]. To address this challenge, researchers have proposed various methods, which can be roughly divided into three categories: fine-tuning methods [1240, 19, 1242], component-based methods [1244, 1245, 1241], and adapter-based methods [289, 1243, 1246]. The difference between the three approaches is illustrated in Fig. 26.

**Fine-tuning Methods** Fine-tuning methods first use a big model to initialize a part or whole parameters of a translation model and then use bilingual data to train the translation model. This approach is a prevalent way of leveraging pre-training to other NLP downstream tasks [18]. For machine translation, due to architectural and objective differences between pre-training and machine translation, it is challenging to fine-tune a big model for translation tasks. To mitigate the architectural difference, Song *et al.* [1240] propose MASS, which uses an encoder-decoder architecture that is the same with neural machine translation models. Therefore, directly fine-tuning MASS with bilingual data becomes feasible. Song *et al.* [1240] demonstrated that fine-tuning MASS with bilingual data could significantly outperform a baseline system without any pre-training in low-resource scenarios. Raffel *et al.* [19] report similar observations using T5 model instead of MASS. However, Yang *et al.* [1242] indicate that simply fine-tuning an MT model initialized by a big model often leads to diminishing gains as the amount of bilingual data increases. They conjecture that this observation is related to the well-known catastrophic forgetting problem and propose a concerted training approach for using the BERT model. The concerted training approach consists of three techniques: an asymptotic distillation, a dynamic switching gate, and a scheduled learning rate policy. First, the asymptotic distillation is used to ensure that the MT model can retain knowledge from the BERT model by adding a distillation objective. Then, the dynamic switching gate is used to avoid catastrophic forgetting of knowledge from BERT model by lowering the update frequency of the BERT model. Finally, the scheduled learning rate policy is used to allow different learning paces of fine-tuning the BERT and training of MT. Yang *et al.* [1242] show that the performance of MT improves significantly with concerted training and BERT on rich-resource language pairs, such as English-German, English-French, and Chinese-English translation tasks.

**Component-based Methods** Component-based methods treat a big model as a component of a translation system. In component-based methods, big models are fixed during the training of MT models, therefore avoiding the catastrophic forgetting problem that the fine-tuning methods may face. Edunov *et al.* [1244] investigate the use of ELMO model [290] for MT. They find that first using a source-language ELMO model to provide contextual-aware representations and then feeding the representations to a Transformer model can significantly improve the performance of MT in low-resource scenarios. Zhu *et al.* [1245] explore effective ways to incorporate BERT into neural machine translation. They propose a BERT-fused model in which the representation from a source-language BERT is fed into all layers of a Transformer model rather than only serving as input embeddings. The BERT-fused model significantly outperforms a Transformer model on both low-resource and rich-resource translation tasks by leveraging BERT models trained on the source language. Weng *et al.* [1241] propose an APT framework for making use of both source-side and target-side big models into NMT. Their approach consists of a dynamic fusion mechanism and a knowledge distillation paradigm. The dynamic fusion mechanism is used to fuse general knowledge from a source-side big model into the NMT encoder. The knowledge distillation paradigm is used to transfer knowledge from a target-side big model into the NMT decoder. Weng *et al.* [1241] investigate the effects of different combinations of incorporating both source-side and target-side

GPTs and BERTs and find that incorporating a source-side BERT and a target-side GPT is the best performing variant.

**Adapter-based Methods** Different from fine-tuning methods and component-based methods, adapter-based methods aim to use big models to perform translation tasks directly. As in monolingual pre-training, big models are trained on monolingual data covering one language. This approach needs an adaption of one or more big models, in which a neural network component (i.e., the adapter) is introduced to mitigate the missing information. Lewis *et al.* [289] investigate using BART, which is a big model with encoder-decoder architecture, to perform translation tasks. Instead of using fine-tuning, Lewis *et al.* [289] replace the inputs of BART model with the outputs from a new Transformer encoder, leaving the BART model as the decoder of an MT system. Despite its simplicity, this approach achieves comparable performance with state-of-the-art Transformer models. Stickland *et al.* [1246] further extends this method with a “within-network” adapter, which introduces small trainable feed-forward neural networks to each layer of the encoder of the BART model. With adapter layers, the performance of BART model adapted to translation tasks can be further improved. Guo *et al.* [1243] take a dramatically different approach. They combine a source-side BERT and a target-side BERT with adapter modules to generate translations. The adapter modules are also feed-forward neural networks inserted between BERT layers and fine-tuned using parallel data. When adapted to autoregressive translation, Guo *et al.* [1243] show that the method can achieve a translation performance that is on par with the state-of-the-art BERT-fused method. When adapted to non-autoregressive translation, the method consistently outperforms the autoregressive Transformer baseline and reduces the inference latency by half.

**Limitations** Despite these successes, monolingual pre-training for MT has limitations. As monolingual pre-training only involves one language, it is inherently incapable of learning cross-lingual knowledge, which is important to machine translation as it always involves more than two languages. Multilingual pre-training, which we shall discuss in the next, offers a potential solution to this problem.

#### 14.2.2 Multilingual Pre-training for MT

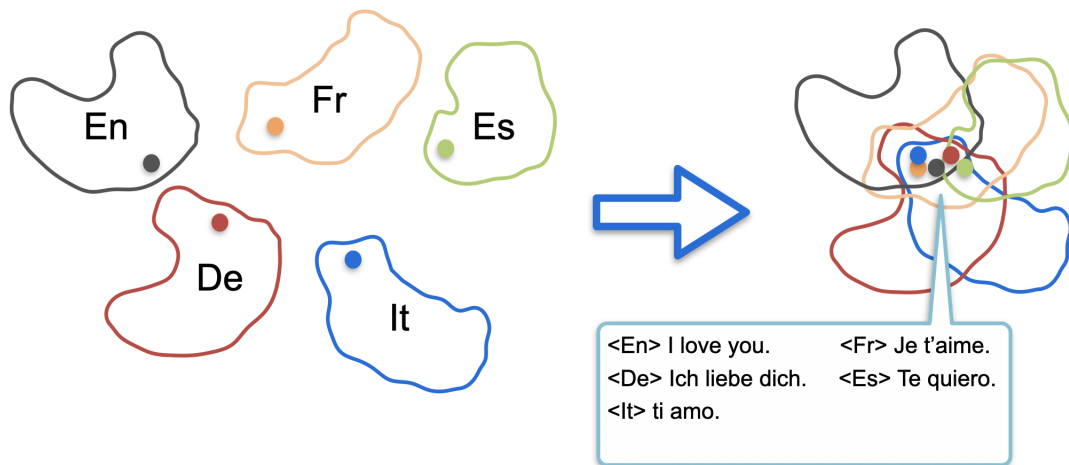

**Fig. 27.** Sentences with the same semantics across different languages should have similar representations.

While monolingual pre-training methods are working very well for machine translation tasks, there are still some limitations for this direction. First, big models such as BERT and MASS are only involved with monolingual data, making it challenging to initialize the entire parameter of the machine translation model. Further, monolingual pre-training ignores the cross-lingual information, which is crucial for machine translation – a natural multilingual problem. Multilingual pre-trained methods were proposed to address this issue. As can be seen in Fig. 27, it makes a simple assumption that sentences with the same semantics across different languages should have similar representations. Multilingual pre-training has a great potential to project different languages in a shared space. Thus it is beneficial to machine translation.

Similar to monolingual pre-training, multilingual pre-training has two research lines for machine translation. The first is the fusion style, which introduces cross-lingual language model pre-training for NMT. It can be viewed as a multilingual extension of BERT-based pre-training focused on the text’s encoder, decoder, or reconstructing parts. The difference is that multiple languages are involved in a single model. The second approach relates to multilingual sequence to sequence pre-training. It usually introduce de-noising objective to train a complete sequence to sequence model, that the full parameter of NMT can be pre-trained. In this section, we will first give a brief introduction of the multilingual fused pre-training methods. Then, we will introduce the multilingual sequence to sequence pre-training methods. Finally, we will talk about the future directions.

**Multilingual Fused Pre-training** extends the monolingual approach to multiple languages and shows the effectiveness of cross-lingual pre-training. The pioneering work about this direction is based on BERT and proposes a cross-language model pre-training method [304]. It proposes two methods to learn cross-lingual language models (XLMs): one unsupervised that only relies on monolingual data, and one supervised that leverages parallel data with a new cross-lingual language model objective. For language modeling, they investigate both casual language modeling (CLM) and mask language modeling (MLM). Both the CLM and MLM objectives are unsupervised and only require monolingual data. For improving cross-lingual pre-training, they introduce a new translation language modeling (TLM) objective. They consider cross-lingual language model pre-training with either CLM, MLM, or TLM is used in combination with TLM. After pre-training, they use these models to initialize the encoder and decoder of the NMT model. Finally, they evaluate the BM on both supervised NMT and unsupervised NMT. On unsupervised machine translation, they show that MLM pre-training is extremely effective. Similarly, they also obtain big improvements in supervised machine translation. They also have some interesting findings, that 1) Adding more languages improves performance on low-resource languages due to positive knowledge transfer. 2) Sampling batches more often in some languages improves performance in these languages but decreases performance in other languages.

Sharing a similar idea with XLMs [304], researchers propose different ways to capture the rich cross-lingual context of words and phrases. ALM extends TLM in a sentence, which alternately predicts words of different languages [1247]. They suggest that Mixing Chinese and English words can draw the distribution of source language and target language in the same space. XLM-T extends the BMs to multilingual translation scenarios [1248]. They initialize MT encoder and decoder with pre-trained cross-lingual encoders and fine-tune the model on multilingual parallel data. XLM-T achieves much better performance on the low-resource languages and is worse on the high-resource languages.

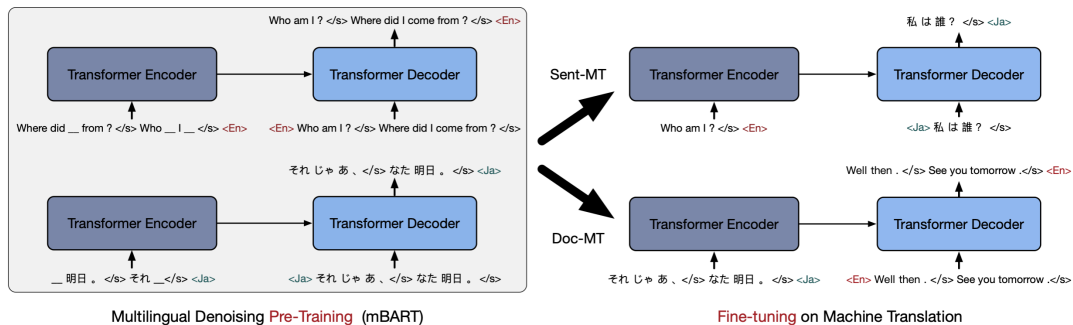

Fig. 28. mBART extends BART to multilingual settings and verifies on different translation tasks.

**Multilingual Sequence to Sequence Pre-training** Different from other fused pre-training approaches for MT [304, 1247], multilingual sequence to sequence pre-training is a complete autoregressive Seq2Seq model. mBART is a representative study of sequence to sequence pre-training. As shown in Fig. 28, it is trained by applying the BART [289] to large-scale monolingual corpora across many languages. The input texts are noised by masking phrases and permuting sentences, and a single Transformer model is learned to recover the texts. mBART is trained on 25 languages and evaluated on unsupervised NMT, supervised NMT, and document NMT tasks. As a benefit of multilingual pre-training, mBART can improve performance even with fine-tuning for languages that did not appear in the pre-training corpora. Experiments show substantial improvements on low resource and medium resource translation but slightly hurts performance when over 25M parallel sentences are available. The main reason is that supervised training is supposed to wash out the pre-trained weights on large scale fine-tuning.

In parallel, there is a bulk of work exploring different multilingual pre-training methods. Different from mBART, Code-Switching Pre-training CSP [1249] replaces a sub-span of the source sentence with their lexical translation in-

stead of “MASK” tokens. In this way, the model learns better from the cross-lingual context. Multilingual Random Aligned Substitution (mRASP) [1250] is a multilingual pre-training method. Different from mBART, mRASP uses parallel multilingual sentence pairs as the pre-training corpus. The key idea in mRASP is its technique of randomly aligned substitution, which brings words and phrases with similar meanings across multiple languages closer in the representation space. They pre-train an mRASP model on 32 language pairs jointly with only public datasets. They carry out extensive experiments on 42 translation directions across diverse settings, including low, medium, rich resources, and transferring to exotic language pairs. mRASP2 [1251] extends mRASP to a larger scale pre-training corpus and introduces sentence-level contrastive learning objectives to close the semantic gap between different languages.

**Future Direction** Multilingual pre-training has shown great success on machine translation tasks, while the challenge remains. The first is about the model size. As different languages are crowded in a single model, the multilingual BM often needs a larger capacity to capture the rich cross-lingual information. Taking mBART as an example, it has 12 transformer layers and 80,000 vocabulary size to achieve better performance, which is much larger than a typical NMT model. How to develop an effective multilingual BM still needs further research. Second, most multilingual pre-training methods achieve substantial improvements on low or medium resource translation tasks, but the improvements on rich resource tasks are not significant enough. Most importantly, the interpretability of transfer learning in multilingual pre-training methods is not well explored and needs further exploration. Understanding how cross-lingual information transfers will benefit the research in this direction.

### 14.2.3 Pre-training for Speech Translation

Speech translation is the translation of speech in one language, typically to text in another. According to the representation type of target language, speech translation can be divided into speech-to-speech translation and speech-to-text translation. Here we focus on speech-to-text translation, the task of translating acoustic speech signals into text in a foreign language [1252]. The traditional speech translation models are based on a consecutive cascaded pipeline of automatic speech recognition (ASR) and machine translation (MT) systems [1253,1254,1255]. Fig. 29 (a) shows a cascaded speech translation framework, in which the ASR system aims to recognize source language speech into the source language text. Then the MT system translates the recognized source language text into target language text. However, these two-stage methods suffer from several problems: (1) serious error propagation, e.g., recognition errors lead to more translation errors; (2) high computation requirements and low translation efficiency, and (3) loss of paralinguistic and non-linguistic information, such as emotion and prosody. The recent successful applications of deep learning to both individual tasks have enabled new opportunities through joint modeling, in what we today call end-to-end speech-to-text translation (dubbed ST), which employs an encoder-decoder model to convert the source language audio sequence to the target language text sequence directly, as shown in Fig. 29 (b). Such models not only have lower inference latency, but they also do not suffer from the problem of errors that propagate from one component to the next.

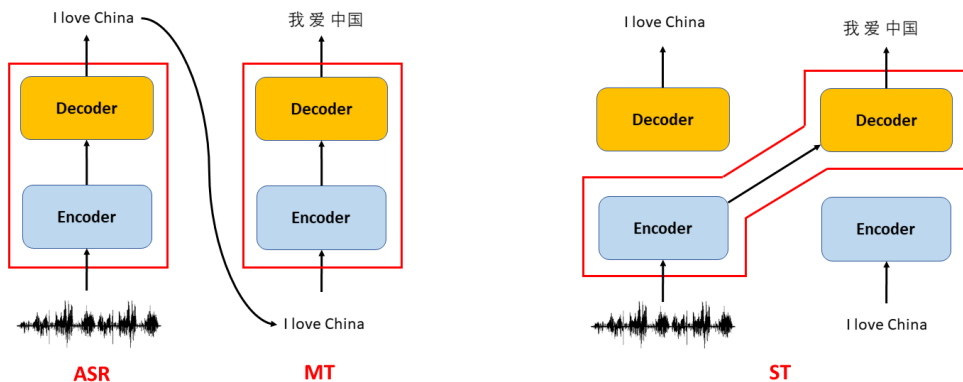

**Fig. 29.** (left) The cascaded speech translation system; (right) The end-to-end speech translation system.

Although the end-to-end speech translation model solves the problems existing in the cascaded model, it also faces several challenges. The biggest challenge of ST is data scarcity: lack of sufficient data to train an ST model for many language pairs. Relatively speaking, there are lots of training data for speech recognition and text translation. However,



the parallel data directly from source language speech to the target language text is minimal [1256,1257]. Second, the ST system still suffers from high modeling complexity due to modality disparity [1258,1259]. Compared to ASR, which only needs to learn how to generate the text sequence corresponding to the speech, leveraging the monotonous alignment of input and output, and MT, which only needs to learn the mapping between different languages, without involving modality transformation, ST is difficult to train because the transformation from source speech inputs to target text outputs is much more complicated than ASR and MT. Pre-training is proposed to address these problems by (1) incorporating additional ASR and MT data and (2) incorporating unlabeled speech and text data.

### Pre-Training with Labeled MT/ASR Data

Pre-training is proposed to incorporate additional ASR and MT data and reduce dependency on scarce end-to-end data. The common way in pre-training is to use an ASR encoder and an MT decoder to initialize the parameters of the ST network correspondingly [1260,1256,1261], as shown in Fig. 30(a). The ST encoder is responsible for transcribing the speech, extracting the syntactic and semantic knowledge, and learning cross-lingual semantics simultaneously, which is more challenging to train than the MT encoder. To strengthen the modeling ability of encoder, Bansal *et al.* [1256] introduced the idea of pre-training an end-to-end ST system using additional ASR training data, where they pre-trained the model on a high-resource ASR task, and then fine-tuned its parameters for ST. Further experiments show that pre-training on ASR helps ST even when the ASR language differs from both source and target ST languages. To reduce the burden of the encoder, Wang *et al.* [1262] proposed a curriculum pre-training method that includes an elementary course for transcription learning with ASR loss, and two advanced courses with frame-based masked language model loss and a bilingual lexicon translation loss, in order to teach the encoder syntactic and semantic knowledge in the pre-training stage.

Another line of work attempts to pre-train a better ST decoder with MT dataset [1263,1264]. Alinejad *et al.* [1263] studied the impact of pre-training an AST decoder using an MT model and proposed an adversarial regularizer to bring the encoder representations of the ASR and MT tasks closer even though they are in different modalities. The combination of ASR and MT in a single ST model poses a heavy burden on the direct cross-modal cross-lingual mapping. To reduce the learning difficulty of decoder, Liu *et al.* [1265] proposed a knowledge distillation approach to improve ST model by transferring the knowledge from the text translation model, and Dong *et al.* [1264] proposed a consecutive decoding strategy, where the key idea is to generate source transcript and target translation text with a single decoder. By pre-training the decoder, the proposed model can directly make better use of the additional large parallel data of MT to enhance the ST training.

Furthermore, Bansal *et al.* [1260] improved the end-to-end ST model with the pre-training method and multi-task learning method when given labeled ASR and MT data. Stoian *et al.* [1266] conducted massive experiments with pre-training on datasets of varying sizes to verify language relatedness or size of the pretraining data yield the biggest improvements. They found that pre-training on a larger amount of data from an unrelated language is much better than pre-training on a smaller amount of data from a related language. Above pre-training work on labeled MT and ASR data still suffers from the vast gap between pre-training and fine-tuning. To address these issues, Wang *et al.* [1267] proposed a tandem connectionist encoding network, which is pre-trained on CTC-based ASR task and MT task in the pre-training stage, and bridges the gap by reusing all subnets in fine-tuning, keeping the roles of subnets consistent, and pre-training the attention module.

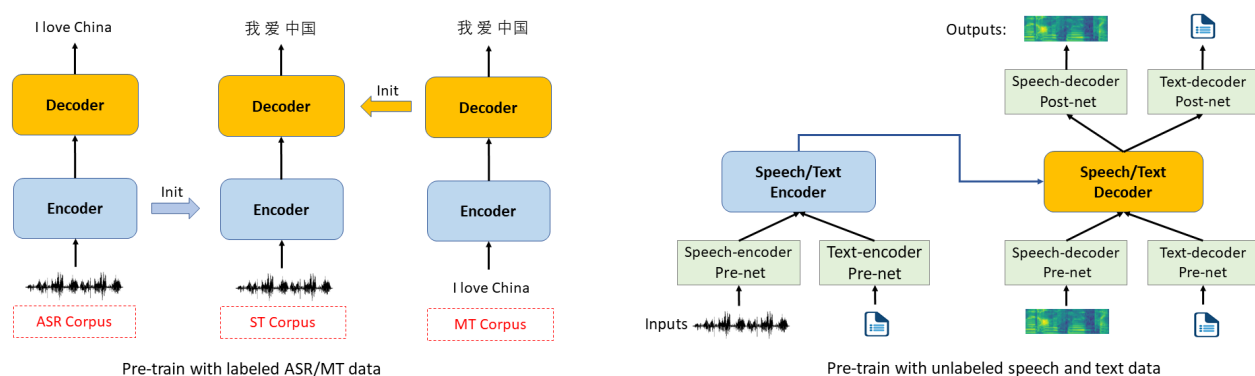

Fig. 30. (left) Pre-train with labeled ASR/MT data; (right) Pre-train with unlabeled speech/text data.

## Pre-Training with Unlabeled Speech/Text Data

Although the above studies of pre-training with labeled ASR and MT data can accelerate the model convergence and boost the translation quality of ST, parallel ASR data and MT data are still limited, so many works attempt to pre-train an ST model with large-scale unlabeled speech or text data [1268,1269,1270,1257]. Compared to text representation learning, there are some challenges in self-supervised approaches for speech representation learning because speech signals are continuous-valued sequences. First, each input utterance in audio has multiple sound units, and there is no prior lexicon of discrete sound units available during the pre-training phase, as the word in NLP applications. Second, sound units have variable lengths with no explicit segmentation in pre-training, and unknown boundary and lexicon complicate masked prediction pre-training like BERT. To deal with these problems, lots of speech BMs are proposed to model audio signal by leveraging unlabeled speech data, such as wav2vec [1271], wav2vec 2.0 [1272], HuBERT [1273], and wavLM [1274]. wav2vec [1271] is a simple multi-layer convolutional neural network optimized via a noise contrastive binary classification task on large amounts of unlabeled audio data. They further introduced wav2vec2.0 [1272] which masks the speech input in the latent space and solves a contrastive task defined over contextual representations in the masked region and quantization of the latent representations. Instead of using contrastive learning, HuBERT [1273] employed a BERT-like pre-training method that benefits from an offline clustering step to generate noisy labels. Furthermore, WavLM [1274] is built based on the pre-training strategy of the HuBERT with utterance mixing strategy and the grep structure change for the Transformer. w2v-BERT [1275] is a framework that combines contrastive learning and mask language model, in which the contrastive module is designed for discretizing continuous speech and a masked prediction module performs masked language modeling with the discretized speech.

Some researches focus on pre-training an encoder based on general-purpose acoustic models (e.g., wav2vec 2.0), or pre-training a decoder based on general-purpose language models (e.g., mBART). To model speech signal better, a line of work attempted at leveraging BM from unlabeled speech as a feature extractor to represent speech signal [1270,1276,1268]. After pre-training, they input the representations produced by the BM to the ST encoder instead of MFCC and log Mel-filterbank in conventional methods. Another line of work explored a more direct approach by learning an ST encoder in a self-supervised fashion only on the speech side [1269,1257]. In [1269], they instead proposed a simple technique to learn a robust speech encoder in a self-supervised fashion only on the speech side, which can utilize speech data without transcription. The proposed model masks certain portions of the speech input randomly and aims to recover the masked speech signals with their context on the encoder side. Wang *et al.* [1257] constructed a sequence-to-sequence model with attention by adding a randomly initialized decoder model on top of a wav2vec 2.0 encoder. They presented a comprehensive study of the impact of existing semi-supervised learning techniques on ST and showed that they greatly reduce the need for additional supervision in the form of labeled ASR or MT parallel data. Moreover, Dong *et al.* [1277] proposed a listen-understand-translate model, in which the proposed framework utilizes a pre-trained BERT model to enforce the upper encoder to produce as much semantic information as possible, without extra data. Le *et al.* [1278] has presented a study of adapters for multilingual ST and shown that language-specific adapters can enable a fully trained multilingual ST model to be further specialized in each language pair.

Recently, representation learning of jointly modeling speech and text has received more and more attention because many pre-training methods still suffer from a limitation that they only learn from one input modality, while a unified representation for both speech and text is needed by tasks such as end-to-end speech translation. Zheng *et al.* [1279] proposed a fused acoustic and text masked language model which jointly learns a unified representation for both acoustic and text input from various types of corpora that combines speech and text. Ye *et al.* [1280] presented a cross speech-text network, an end-to-end model for speech-to-text translation, which takes both speech and text as input and outputs both transcription and translation text. Xu *et al.* [1281] proposed a stacked acoustic-and-textual encoding method for ST, where the encoder begins with processing the acoustic sequence as usual, but later behaves more like an MT encoder for a global representation of the input sequence. Bapna *et al.* [1282] built a single encoder with the BERT objective on the unlabeled text together with the w2v-BERT objective on unlabeled speech. In addition to unlabeled speech and text data, the above work also requires pairs of ASR data or MT data to learn joint representation. In order to break through this limitation, Ao *et al.* [1283] proposed a unified-modal SpeechT5 framework that explores the encoder-decoder pre-training for self-supervised speech/text representation learning, as shown in Fig. 30(b). They converted all spoken language processing tasks into a speech/text to speech/text format and proposed a novel joint pre-training method to utilize cross-modal information by leveraging the unlabeled speech and text data. The proposed SpeechT5 can support generation tasks such as automatic speech recognition and speech translation. Li *et al.* [1259] presented a simple yet effective approach, which only fine-tunes the layer norm and attention parameters of BMs, to build multilingual ST through efficient transfer learning from a pre-trained speech encoder and text decoder.

## Future Directions

In recent years, speech translation has made great progress due to deep learning and pre-training methods. Recently several extensions of these pioneering works were introduced: low resource ST [1256], unsupervised ST [1284], end-to-end speech-to-speech translation (S2ST) [1285, 1286], robust ST [1287, 1288], multilingual ST [1289], and simultaneous translation [1290]. Particularly, speech to speech translation is highly beneficial for breaking down communication barriers between people who do not share a common language. Compared to cascaded systems, S2ST systems have some potential advantages: 1) S2ST has reduced computational requirements and lower inference latency; 2) It can avoid error propagation across components by training end-to-end; 3) S2ST can retain paralinguistic and non-linguistic information during translation, such as speaker’s voice and prosody; 4) S2ST can work on languages without written form and is easier to generate pronunciations of words that do not need to be translated, such as names and proper nouns. In practice, S2ST still suffers from data scarcity and low performance, and it is promising to improve the translation quality by leveraging self-supervised pre-training, such as generative spoken language model (GSLM) [1291] spoken encoder-decoder pre-training framework SpeechT5 [1283].

Besides, simultaneous translation, which performs translation concurrently with the source speech signal, is widely useful in many scenarios such as international conferences, negotiations, press releases, and legal proceedings. The conventional cascaded approach uses a pipeline of streaming ASR followed by simultaneous MT, but suffers from error propagation and extra latency. Recently, with rapid improvements in machine translation, speech recognition, and speech synthesis, there has been exciting progress towards end-to-end simultaneous translation [1292, 1290]. Current BMs for speech translation are, such as wav2vec [1272] and HuBERT [1273], which build on a bidirectional Transformer encoder and are not fully suitable for simultaneous translation. Hence, how to effectively pre-train a streaming model is also a very promising research direction.

Although a series of methods have been proposed to address the challenges of speech translation, data scarcity is still the key problem for end-to-end speech translation and how to make more effective use of pre-training technology is a direction worth exploring. Future work includes (1) joint pre-training with aligning speech and text, (2) effectively pre-training with faster speed and fewer resources, and (3) effectively fine-tuning from pre-trained speech and text model. First, most existing pre-training methods still only learn from one input modality, while a unified representation for both speech and text is needed by tasks that need modality transformation. Although some work attempts to jointly pre-train a model with speech and text data, they can not bridge the modality gap between speech and text, and they can not really align the acoustic feature and text phoneme like unsupervised ASR [1293]. Second, previous pre-training methods, especially for the speech model, need lots of GPU resources and computational time. For example, based on HuBERT Base, HuBERT Large and X-Large extract features from the 9-th transformer layer of the second iteration HuBERT Base for clustering and use those labels for training on 128 and 256 GPUs, respectively, for 400k steps. So this is a practical research direction, which will promote the development and broad application of pre-training technology. Third, at present, there are a large number of BMs (e.g., wav2vec, HuBERT, BERT, and BART) that have been pre-trained individually. Effectively fine-tuning an ST model from existing pre-trained speech and text models is worth exploring as well.

#### 14.2.4 Pre-training for MT Evaluation

Evaluating machine translation systems is challenging because for one source sentence, there are diverse corresponding target translations, and it is time-consuming and labor-intensive to always employ human translators for machine translation evaluation. In order to automatically evaluate machine translation systems, some researches propose to directly compare system outputs and human-annotated references at the surface level. For instance, BLEU [720] simply counts the  $n$ -gram overlap between the system output and the gold reference, and TER [1294] measures the amount of editing that a human would have to perform to change the system output to exactly match the reference. Although these metrics - which estimates translation quality based on surface-level similarity - are easy to use, they can not effectively capture the semantic-level similarity between system outputs and gold references, which is more critical for translation quality estimation [1295].

Inspired by the finding that the representations learned by BMs are useful semantic features [18, 20], many researchers direct their attention to semantic-level translation quality estimation using BMs [1296, 1295]. Such kind of pre-training based evaluation methods can be roughly divided into two categories: *reference-based* metrics that require human-annotated references and *reference-free* metrics that estimate the quality of system outputs using no references. We will introduce some representative methods for both two categories of evaluation metrics.

#### Reference-Based Evaluation

Reference-based evaluation metrics estimate the quality of system outputs based on their similarity compared with gold references. Rather than simply consider the surface-level similarity, we will introduce some evaluation metrics that compare system outputs and references using semantic representations learned by BMs.

- *Meant 2.0* [1296]: uses the word embedding proposed by [52] to calculate the lexical similarity, which is then used to compute the phrasal similarity between the semantic frames extracted from system outputs and gold references. Specifically, a shallow semantic parser is used to extract semantic frames. Using word embeddings, Meant 2.0 can exploit semantic-level word alignment rather than surface-level exact match. However, the word representation used in Meant 2.0 is not context-aware, limiting this evaluation metric’s effectiveness, especially for words that have various meanings. Moreover, Meant 2.0 relies on the semantic parser, which may be noisy in some cases and even not available for some low-resource languages.

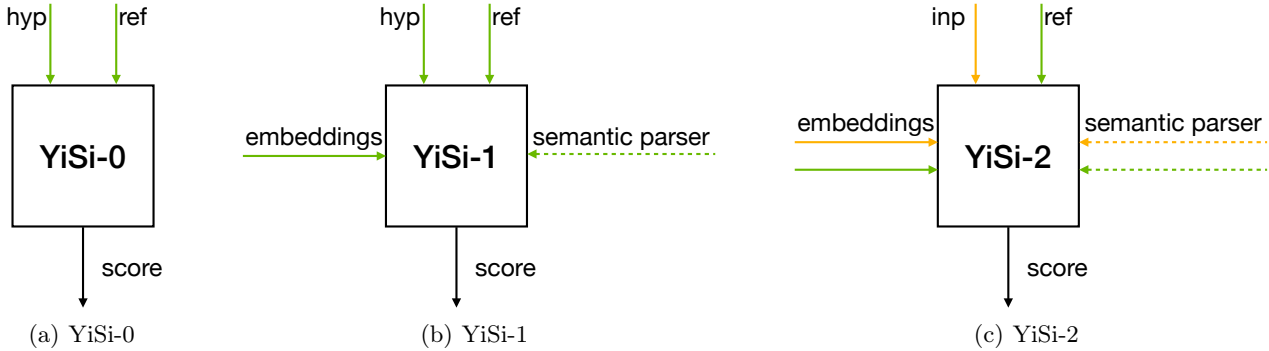

**Fig. 31.** Illustration of different versions of YiSi. The dashed arrow means that the semantic parser is optional. YiSi-0 only uses hypotheses and references to estimation translation quality, while YiSi-1 utilizes additional continuous embeddings and a semantic parser. YiSi-2 is different from the former two versions mainly because YiSi-2 is reference-free, which uses cross-lingual embeddings to estimate the similarity between inputs and references.

- *YiSi* [1297] is a unified semantic MT quality evaluation and estimation metric for languages with different levels of resources. The basic idea of YiSi is similar to Meant 2.0, but YiSi uses the output of BERT [18] as context-aware representation. Fig. 31 plots different versions of YiSi. YiSi-0 uses the longest common character sub-string accuracy to evaluate the similarity between system outputs and gold references, which is still a surface-level metric. YiSi-1 employs additional embeddings to compute cosine similarity as the lexical similarity at the semantic level. Optionally, YiSi-1 also uses a semantic parser to estimate the structural semantic similarity. YiSi-2 is a cross-lingual variant of YiSi-1, which uses cross-lingual embeddings to directly estimate the lexical similarity between source sentences and references. YiSi-2 is designed for languages whose references are difficult to obtain.
- *BERTScore* [1295] also computes lexical similarity using contextual embeddings, which requires no external tools to annotate linguistic structures. Fig. 32 gives an example of the computation of BERTScore, which contains three stages: pairwise cosine similarity estimation, greedy matching, and importance weighting. The experiments across several scenarios indicate that BERTScore is an effective metric for evaluating system outputs against golden references. The authors also use an adversarial paraphrase detection task to show that BERTScore is more robust to challenging examples compared with previously proposed evaluation metrics.
- *BLEURT* [1298] is metric using transfer learning to directly predict the quality score of system outputs. Formally, given a system output  $\hat{\mathbf{x}}$  and a reference  $\mathbf{x}$ , BLEURT firstly maps the sentence pair  $(\mathbf{x}, \hat{\mathbf{x}})$  into a continuous vector using BERT:  $\mathbf{v}_{\text{BERT}} = \text{BERT}(\mathbf{x}, \hat{\mathbf{x}})$ . The vector  $\mathbf{v}_{\text{BERT}}$  is then fed into a linear transformation to predict the quality score:

$$\hat{y} = \mathbf{W}\mathbf{v}_{\text{BERT}} + b, \quad (24)$$

where  $\mathbf{W}$  and  $b$  are both trainable parameters. The training process of BLEURT consists of three stages: (a) initializing the model using a pre-trained BERT; (b) training the model on large-scale synthetic data, where  $\hat{\mathbf{x}}$  is obtained through randomly perturbing sentences from Wikipedia, and the quality score is automatically labeled using existing metrics (e.g., BLEUScore, BLEU, ROUGE); (c) fine-tuning the whole model towards human ratings using a regression loss. Unlike previous semantic-level evaluation metrics that leverage BMs to extract semantic representations, BLEURT fine-tunes the BM into a quality estimation-oriented model to predict translation quality.

Other studies use BMs to perform a reference-based evaluation for machine translation systems. [1299] propose a hybrid model to predict the quality score. Specifically, they fine-tune two RoBERTa [292] models on the STS-B and MNLI benchmarks to estimate the semantic similarity and logical entailment between system outputs and gold references. They also use the perplexity of GPT-2 [48] as the measurement of sentence intelligibility. All the three types of scores are then aggregated using a neural network into a single quality score, which is then bounded between 0 and 1 through a neural calibrator. [1300] find many embedding-based evaluation metrics (e.g., BERTScore [1295], earth

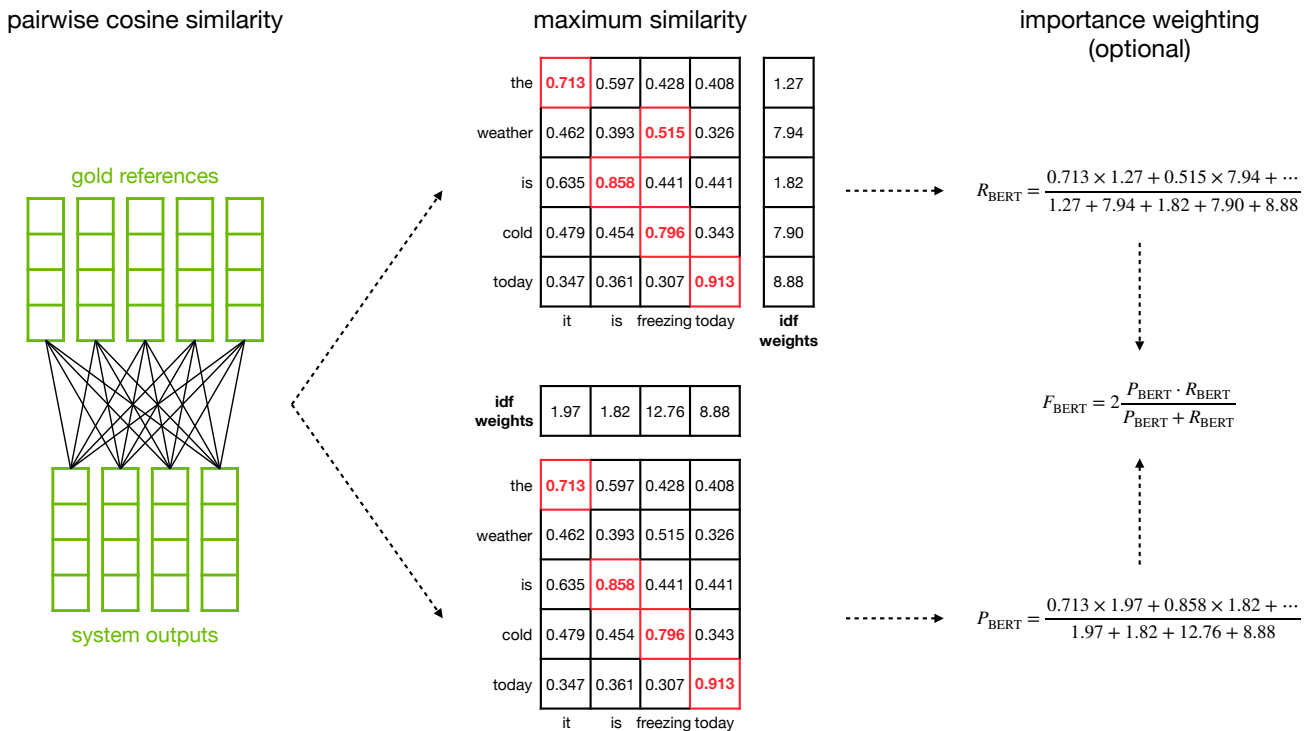

**Fig. 32.** Illustration of the computation of BERTScore. Given the system outputs and gold references, BERTScore firstly estimates the pairwise cosine similarity based on BERT representations. The complete score matches each reference token to an output token to compute recall, and each output token to a reference token to compute precision. BERTScore uses greedy matching to maximize the matching similarity score, which means that each token is matched with the most similar token in the other sentence. Optionally, BERTScore uses the inverse document frequency (i.e., IDF) as the importance weight for each token when estimating the precision and recall.

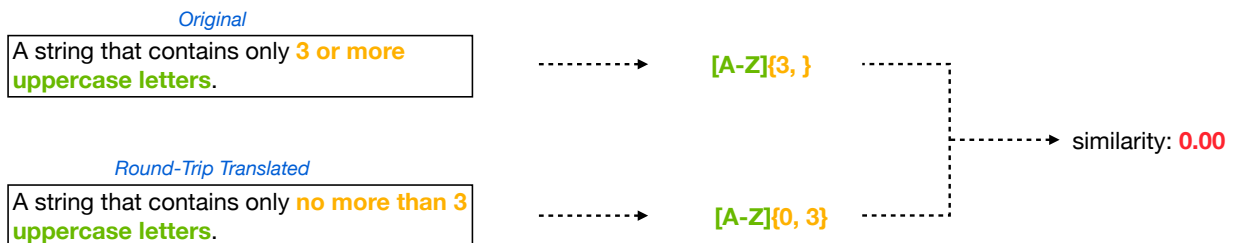

**Fig. 33.** An example of SemMT. Both the original and round-trip translated sentences are abstracted using regular expressions.

mover's distance) correspond to the optimal transport problem, they further propose a family of new evaluation metrics based on more general unbalanced optimal transport problem, namely lazy earth mover's distances. [1301] propose the language model augmented relevance score (MARS), which uses off-the-shelf language models to generate augmented references based on both the input and the human-annotated reference. The system outputs are evaluated using both the human-annotated reference and the augmented references. Experiments show that MARS higher correlation with human reference judgements than several previously proposed metrics on many NLG tasks.

## Reference-Free Evaluation

Since high-quality references are unavailable for many languages and domains, many researchers attempt to develop reference-free evaluation metrics, which estimate the quality of system outputs based on only the source-language inputs. Compared with reference-based metrics, reference-free metrics are more flexible and scalable. We will describe some pre-training based reference-free evaluation metrics in this section.

- *SemMT* [1302] applies round-trip translation to measure the semantic similarity between the original and translated sentences. This metric assumes that the semantics concerning logical relations and quantifiers can be captured by

regular expressions (or deterministic finite automata). More concretely, the authors use regular expressions to abstract the original and round-trip translated sentences and then calculate the similarity using the abstracted sentences. The resulting SemMT is able to detect logical translation errors, such as “include” vs. “exclude”, and “at least” vs. “at most”, which are difficult to capture for lexical and syntactic metrics. Fig. 33 plots an example for the computation of SemMT.

- *KoBE* [1303] is a simple and effective metric that grounds the entities detected in the source and translated sentences and then calculate the recall of the grounded entities found in the translated sentence vs. those found in the source sentence. KoBE is potentially effective in detecting under-translation of entities, which is a widely-cited weakness for neural machine translation [1304, 1305].
- *SentSim* [1306] combines sentence-level similarity measures with previously proposed metrics to improve correlation with human ratings. The authors demonstrate that their method performs well in reference-based and reference-free evaluation tasks.

There are also some other studies concerning reference-free machine translation evaluation. [1307] propose to train a quality estimation model which takes in source-language inputs and system outputs and output the quality score. Their model is trained using two tasks: score a translation and rank two translations. Human assessors’ scoring and ranking results can be used as training data for the two tasks, respectively. [1308] adopt the semantic embeddings of pre-trained languages to perform round-trip translation based quality estimation, and they also find that the proposed evaluation method is robust to the choice of the backward translation system. [1309] systematically investigate a range of metrics based on cross-lingual big models and find that there exists a semantic mismatch between representations of mutual translations. They thus propose a post-hoc re-alignment method to reduce this mismatch. Moreover, they also employ an additional language model to better punish translationese, i.e., low-quality literal translations [1310]. [1311] leverage pre-trained multilingual NMTs model to score system outputs with references. Surprisingly, they find that when scaling up the NMT model, the score predicted by the model can match the performance of BLUE.

## Future Directions

Most existing pre-training based machine translation evaluation metrics adopt the idea of utilizing the semantic representation learned by big models to estimate the similarity between system outputs and gold references (reference-based metrics) or between system outputs and source-language inputs (reference-free metrics). Inspired by the recent success of language model prompting, we may directly use natural language sentences as prompts to steer extremely-large language models to predict the quality score in the future. Moreover, we can evaluate machine translation systems in more aspects beyond translation quality, such as the cultural bias, the sentiment, the readability, or the text style, which are essential in some specific application scenarios.

### 14.3 Challenges and Future Directions

We can easily see that many research works address the application of BMs in neural machine translation, and some successes have been achieved. However, compared to other NLP tasks, the application of BMs could not make a breakthrough in translation quality, and it usually cannot outperform the data augmentation methods like back-translation when dealing with unlabeled data. Here, we present some challenges that may hinder big model applications’ success.

#### 14.3.1 Objective Divergence

We know that almost all BMs are optimized with self-supervised objectives. For example, language models, masked language models, and reconstruction loss are employed to serve as objectives. All the objectives except language models can be formalized as a mapping from an input corruption to the original input or a variant of the input. The language model utilizes the prefix to predict the next token. Therefore, most of the BMs learn transformations only in the semantic space of the same language and can lead to powerful general representations for that language. Accordingly, they are usually employed to enhance the encoder or the decoder of an NMT model instead of directly augmenting the end-to-end encoder-decoder model.

In contrast, machine translation aims to transform the semantic space in one language to the semantic space in another language. That is to say, cross-lingual mapping is the critical component to learning. Its cross-lingual objective is very different from the monolingual objectives of the big models. The objective divergence may be one of the key factors that hinder the success of the BMs in NMT. Thus, one potential future trend is to bridge the gap between the two kinds of objectives.

### 14.3.2 Exploration of Diverse Data

Currently, texts are the main research target in machine translation, and speech also attracts more and more attention. Text-based and speech-based BMs are now available and are applied to NMT. However, machine translation is not only about a single modality, and different modalities such as text, speech, and visual information are all helpful to improve translation quality. Unfortunately, it is rare to see that multimodal BMs are well investigated in machine translation. It is an attractive research topic and could be a future trend.

In addition, the current application follows a decoupled methodology. Namely, we first learn a big BM on massive unlabeled data, and then employ this big model to enhance the NMT model on labeled bilingual data. This kind of usage cannot take full advantage of diverse data. It remains a challenge to learn an MT-oriented BM that fully utilizes diverse data resources such as unlabeled monolingual texts and labeled bilingual corpora. We believe that it must be an exciting research trend.

## 15 Application in Text Generation

*Authors: Haoran Li<sup>\*</sup>, Junwei Bao<sup>\*</sup>, Yingwei Pan<sup>\*</sup>, Xiaodong He<sup>✉</sup>*

### 15.1 Background

Text generation is a task to convert the input, linguistic or non-linguistic, into text [415,416,417], with a series of important applications in the real world, such as machine translation [418,419,4], text summarization [420,421,422], dialogue response generation [423,424,425], image captioning [14,426,427], and so on. Generally, a qualified output text should be fluent, grammatically correct, semantically logical, faithful to the input, and easy to understand.

From the input view, text generation tasks can be divided into text-to-text generation, data-to-text generation, and vision-to-text generation. The text-to-text generation task takes text as the input and automatically generates another piece of text as output, for example, translating text from one language to another, condensing multiple documents into summaries, and generating responses for given conversation contexts. The data-to-text generation task automatically generates text from non-linguistic data, for example, producing weather forecasts from graphical weather predictions, generating sports reports from game records, and mapping entities and relations into a description. The vision-to-text generation task aims to generate text for given visual information in the forms of image or video, for example, describing image or video with text, answering questions related to the image or video, and generating stories for a sequence of images.

From the view of method, text generation can be classified into rule-based models, statistics-based models, and neural-network-based models. Rule-based models dominated the field before the 2000s, among which template-based approaches [1312,1313,1314] are the most commonly adopted. These methods directly map non-linguistic input to the linguistic surface structure [1315] relying on hand-crafted templates, which limits their applications in more sophisticated scenarios.

Availability of large-scale annotated corpora enables statistics-based text generation models [1316,1317] that predict words in output sentences given the contexts, which takes less human effort. There are two lines of research for statistics-based methods [1318]. The first one re-ranks candidate output during text generating by training a  $n$ -gram model [1316] or syntactic model [1316]. A second one optimizes model parameters by maximizing an objective function at the generation decision level, *e.g.*, generating text with a particular linguistic style [1319] or topic structure [1320].

In the recent ten years, with the rapid development of deep learning, neural-network-based text generation models that generate the output given the input in an end-to-end manner achieved significant advantages over statistics-based methods. The most commonly used framework is an autoregressive text generation that produces output given the previously generated words word-by-word [4], and another is a non-autoregressive text generation that conditions the output probabilities only on the input [1321].

Similar to statistics-based text generation models, neural-network-based models are mainly trained with large-scale human-annotated data without using unlabeled text. While in fact, raw text data contain abundant linguistic knowledge, which is abundant and easily available. More recently, big models, such GPT [26], MASS [1240], UniLM [303], BART [289], T5 [19], PEGASUS [299], and ProphetNet [300], have obtained state-of-art performances in a wide range of text generation tasks. These models are trained with raw text data via self-supervision based on auto-regressive pre-training, which greatly promotes the development in text generation.

---

Haoran Li, Junwei Bao and Yingwei Pan contribute equally.

Xiaodong He (hexiaodong@jd.com) is the corresponding authors of Section 15.

In the remaining contents of this section, we first illustrate text generation tasks from the following three categories: text-to-text generation, data-to-text generation, and vision-to-text generation. Then, we briefly describe two kinds of basic text generation architectures, including autoregressive text generation and non-autoregressive text generation. Next, we introduce several typical BMs for text generation. In the end, we present future directions for text generation.

## 15.2 Tasks for Text Generation

Regarding the type of input, we briefly introduce text generation tasks ranging from text-to-text generation, data-to-text generation, and vision-to-text generation.

### 15.2.1 Text-to-Text Generation

The input of text-to-text generation is unstructured text, such as sentence, paragraph, and document, and typical text-to-text generation tasks include machine translation, text summarization, text simplification, dialogue response generation, paraphrases generation, question generation, and so on. Machine translation [418, 419, 4] aims to translate text from one language into another, which is a classic cross-lingual text generation task. The machine translation task's nature is maintaining semantically consistent between the input and the output. Text summarization [420, 421, 422] aims to condense the input text into a summary, facilitating a quick understanding of the key points of the input, which can be accomplished by extractive or generative approaches. The core of the text summarization task is capturing the gist of the input contents, and meanwhile, avoiding generating unfaithful information. Text simplification [1322, 1323, 1324] is a task to reduce the linguistic complexity of a text while still retaining the original meaning of the input, which can be achieved by lexical simplification [1325], syntactic simplification [1326], and semantic simplification [1327]. The goal of the text simplification task is to make the input easier to read and, similar to the text summarization task, keep it identical in meaning to the input. Dialogue response generation [423, 424, 425] is a task to produce a meaningful response given the previous conversation contexts. According to the goal of dialogue, dialogue systems can be divided into task-oriented dialogue that aims to complete a particular task and non-task-oriented dialogue that aims to carry out conversations with users in open domains. Paraphrase generation [1328, 1329, 1330] aims to express the same meaning as the input text with different words, which can be used as a method for data augmentation to benefit many NLP applications, such as question answering [1331], information retrieval [1332], and dialogue system [1333]. Higher lexical diversity is essential for paraphrase generation to enhance generalization capability for downstream applications. Other text-to-text generation tasks include text style transfer [1334, 1335, 1336], question generation [1337, 1338, 1339], news headline generation [1340, 1341, 1342], narrative generation [1343, 1344, 1345], poetry generation [1346, 1347, 1348], review generation [1349, 1350, 1351], and so on.

Compared with traditional neural network-based models without pre-training, BMs are widely believed to possess knowledge, linguistic or non-linguistic, from massive data, which can benefit the downstream text-to-text generation. Generally, BMs can be directly applied to monolingual text-to-text generation. For cross-lingual generation tasks, such as machine translation, cross-lingual summarization [1352, 1353], there are some flexible strategies to be formulated. For example, MASS pre-trains the model on the monolingual data of the source and target languages. BART adds a randomly initialized encoder with separated vocabulary, which can be learned from bitext. The new encoder can be trained end-to-end, mapping the words in the new language into the original one that BART can process.

### 15.2.2 Data-to-Text Generation

In addition to text-to-text generation, generating text based on structured data as input, namely data-to-text generation, is also a crucial task. Typically, structured data, including tables and graphs, are the widely-used type of data source which has a formal structure and contains valuable information. Understanding the meaning of these structured data and serializing its content into text is an important problem in artificial intelligence (AI) [1354]. Building such a model has much potential to support other applications, such as question answering, conversational agents, and search engines [1355, 1356, 1357]. For instance, table- or knowledge-graph-based question answering (TBQA & KBQA) systems can retrieve table regions or graph regions as answers by matching the question and the corresponding generated text. Another example is that after describing a web table with natural language text, a search engine can retrieve tables as answers by regarding the corresponding text as keys and tables as answers. According to the form of the input structure, different fine-grained sub-tasks including **table-to-text** and **graph-to-text** are widely explored and researched in recent decades.

For **table-to-text** generation, the input tables usually include web tables, scenarios consisting of a set of database records, and infoboxes consisting of attributes and values. Another well-known name for this task with database records as input is data-to-text which is classified as table-to-text in this paper. Conventional approaches [1358, 1359]



for table-to-text tasks include two steps: table content selection and surface realization of a generation. Later, end-to-end models combine the two steps into a unified framework with a joint content plan and surface realization [1360, 1361]. Other methods [1354, 1362, 1363, 1364, 1365, 1366] achieve improvements by exploring more effective table-to-text neural generators. Since the BMs achieves remarkable performance for text-to-text generation as described before, research for improving table-to-text generation with pre-training techniques are widely explored [1367, 1368, 1369, 1370, 1371, 166]. For instance, to better model the input structure of tables, method [1372] introduces two self-supervised tasks, namely number ordering and significance ordering, to facilitate the learning of table representation. More recently, a BM [1373] that is trained with tables and their contexts is proposed, and as a structure-aware pre-trained one, it can understand the structured input table and generate fluent text.

For **graph-to-text** generation, the input of the task is formalized as graphs, *e.g.*, abstract meaning representation (AMR) and knowledge graphs (KG). Various methods have been proposed to describe graphs or sub-graphs with sentences for different domains to this task. An intuitive approach for modeling graph data is linearization, based on which approaches for graph-to-text generation can be formalized as text-to-text tasks. The first neural method for AMR-to-text generation [1374] is proposed by linearizing the input graph as a sequence. In addition, KG triples are serialized as a sequence and then fed as input to the models to produce descriptive sentences [1375, 1376, 1377, 1378]. However, these approaches miss the opportunities to handle graph structures to enhance the generation performance. Recently, graph neural networks (GNNs) have been widely explored for modeling graph structures. Approaches [1379, 1380, 1381, 1382, 1383, 1384, 1385, 1386] leverage GNNs and variants to directly encode graph structures. Another line of research [1387, 1385, 1388, 1389] inject the structure information into a sequence-based model, *e.g.*, Transformer. Same as the table-to-text task, pre-training methods also boost the graph-to-text generation. Study [1390] leverages the big model GPT-2 [48] for AMR-to-text generation and propose cycle consistency to enhance the adequacy. Method [1386] investigates BART and T5 models, which are of the transformer-based encoder-decoder framework in AMR-to-text generation. More recently, scaffolding objectives are explored in method [1391] where gains are shown in low-resource graph-to-text settings.

### 15.2.3 Vision-to-Text Generation

Computer Vision (CV) and Natural Language Processing (NLP) are the two most fundamental disciplines under a broad area of Artificial Intelligence (AI). CV is regarded as a field of research that explores the techniques to teach computers to see and understand digital content such as images and videos. NLP is a branch of linguistics that enables computers to process, interpret and even generate human language. With the rise and development of deep learning over the past decade, there has been a steady momentum of innovation and breakthroughs that convincingly push the limits and improve the state-of-the-art of both vision and language modeling. An interesting observation is that the research in the two areas starts to interact, and many previous experiences have shown that doing so can naturally build up the circle of human intelligence. In between, vision-to-text generation, as one of the “hottest” topics in this area, is the task of automatically producing a natural sentence that describes the visual content in images/videos. This task boosts visual perception with a more comprehensive understanding and diverse linguistic representations, which could have a great potential impact, for instance, on robotic vision or on helping visually impaired people. Nevertheless, the vision-to-text generation task is very challenging, as a description generation model should capture not only the objects, scenes, and even the activities presented in the image/video, but also be capable of expressing how these objects/scenes/activities relate to each other in a natural sentence.

Taking the inspiration from neural machine translation [418], the mainstream of modern vision-to-text generation techniques follows the structure of the CNN encoder plus RNN decoder [1392, 14, 1393, 1394, 427, 1395, 1396, 1397, 1398, 1399, 1400] by casting this task as a sequence to sequence problem. The input visual content (*e.g.*, the sequence of local regions/frames/clips) is first encoded via CNN/RNN, and a decoder of RNN is leveraged to produce the variable-length sentence. In addition, inspired by the successes of Transformer self-attention networks [25] in NLP field, recent attention has been geared toward exploring Transformer-based encoder-decoder structure [1401, 1402, 1403, 1404, 1405] for vision-to-text generation. In particular, different from the CNN encoder plus RNN decoder that capitalizes on RNN to model word dependency, the Transformer-based encoder-decoder paradigm fully utilizes an attention mechanism to capture the global dependencies among inputs. Several multi-head self-attention layers are commonly stacked for the visual encoder to model the self-attention among input image regions/frames/clips. The sentence decoder consists of several stacked multi-head attention layers, each consisting of a self-attention sub-layer and a cross-attention sub-layer. More specifically, the self-attention sub-layer is first adopted to capture word dependency. The cross-attention sub-layer is further utilized to exploit the co-attention across vision (image regions/frames/clips from the encoder) and language (input words).

Sparked by natural language pre-training, a new wave of vision-language pre-training methods have been proposed recently to learn pre-trainable encoder-decoder structure for the vision-to-text generation downstream task. In particular, Unified VLP [1406] constructs a single-stream BERT-type encoder-decoder structure, which can be generalized

to both vision-language understanding and vision-to-text generation tasks. TDEN [1407] utilizes a two-stream decoupled design of encoder-decoder that reflects the mutual relationship between different modalities or vision-language proxy tasks for pre-training. HERO [1408] further capitalizes on a hierarchical BERT-type structure for video-language pre-training, which consists of a cross-modal transformer for exploring cross-modal interaction and a temporal transformer for learning contextualized video embeddings. Recently, CoCo-BERT [1409] pre-trains a two-stream BERT-type encoder-decoder structure over a large-scale video-sentence dataset [1410] by additionally strengthening video-language reasoning through cross-modal matching and denoising, aiming to facilitate video-to-sentence generation.

### 15.3 Architectures for Text Generation

In this section, we introduce two categories of text generation architectures for neural-network-based text generation, *i.e.*, autoregressive text generation and non-autoregressive text generation.

#### 15.3.1 Autoregressive Text Generation

Autoregressive text generation architecture predicts output tokens iteratively following a left-to-right order, in which the previously generated ones are conditioned. In other words, autoregressive text generation resolves the text generation task into a succession of next token predictions. There are two paradigms for autoregressive text generation, *i.e.*, encoder-decoder-based and decoder-only-based.

For the encoder-decoder paradigm, the input  $\mathbf{x}$  are first encoded into hidden representations and then decoded into output  $\mathbf{y}$  in a word-by-word manner. More specifically, the probability of a generated token  $y_i$  is conditioned on the input  $\mathbf{x}$  and the previous generated sequence:

$$P(\mathbf{y}|\mathbf{x}) = \prod_{i=1}^I P(y_i|y_1, y_2, \dots, y_{i-1}, \mathbf{x}) \quad (25)$$

There are several neural networks that can be used to implement autoregressive text generation as defined in Equation 25, such as RNN and Transformer. For RNN, encoding and decoding processes are in strict left-to-right fashions, which limits information interaction between the encoder and the decoder. Transformer solves this problem via a self-attention mechanism, where the token at each position can attend to all other positions in the input. Meanwhile, the process of decoding is maintained in an autoregressive fashion by masking the future positions.

Most of the pre-trained models, including MASS, T5, BART, are trained with encoder-decoder paradigm based on Transformer, where the input  $\mathbf{x}$  in Equation 25 is randomly perturbed text from a normal text  $\mathbf{y}$ . There are also existing models, such as GPT [26] and CTRL [65], adopting a decoder-only paradigm that is trained via the following objective:

$$P(\mathbf{x}) = \prod_{i=1}^I P(x_i|x_1, x_2, \dots, x_{i-1}) \quad (26)$$

where unidirectional self-attention masks are adopted to guarantee that each token can only attend to the preceding positions.

#### 15.3.2 Non-Autoregressive Text Generation

Non-autoregressive text generation models produce the output sequence without considering the sequential dependencies between generated tokens in the output, which can speed up the decoding compared with autoregressive generation.

A simple non-autoregressive text generation method [1321] first predicts the length of the output sequence, and then predicts the output conditioned only on the input:

$$P(\mathbf{y}|\mathbf{x}) = P_L(L|\mathbf{x}) \times \prod_{i=1}^L P(y_i|\mathbf{x}) \quad (27)$$

where  $L$  denote the target length.

Insertion-based text generation models [1411,1412] present a more flexible decoding approach that generates an output sequence with an arbitrary order by predicting insertions of words into any position of the output sequence.

They have achieved competitive or even better performances compared with the autoregressive text generation models on the tasks of machine translation, word order recovery, code generation, and image captioning.

Existing work [1413] shows that BMs can also be helpful for non-autoregressive text generation performance. The most recent work [1414] proposes a non-autoregressive pre-training method with a cross-stream visible n-stream strategy. However, most of the BMs are built upon an autoregressive manner. Thus, we focus on BMs for autoregressive text generation in this survey.

## 15.4 Future Directions

With the sustainable development of big models in recent years, text generation has been extensively applied in various scenarios as an essential part of NLP. However, due to the difficulty and variety of text generation tasks and the high complexity of big models, we present three promising future directions for better adopting big models to text generation.

### 15.4.1 World-Knowledge-Aware Big Models for Text Generation

Although big generative models can learn rich semantic and syntactic information from raw text data and enhance downstream text generation applications, many do not explicitly model world knowledge. As a result, they may suffer in cases where world knowledge is required during text generation. On the other hand, there has been efforts devoted to incorporating external knowledge into BERT. For example, ERNIE [162], KnowBERT [180], WKLM [164], KEPLER [163], and ERICA [189] learn entity and relation representations from knowledge bases. SKEP [1415] and SentiLARE [600] integrate sentiment knowledge into language modeling. More recently, KGPT [166] proposes a knowledge-aware pre-training method based on Wikidata, while this model is trained with pseudo-data, which is hardly scalable. How to mine world knowledge in large-scale raw data and then explicitly inject the knowledge into BMs for text generation is an interesting direction.

### 15.4.2 Big Models for Controllable Text Generation

In many real-world scenarios, the output of the text generation model should fulfill a specific goal, *i.e.*, the attributes, such as style [1416], length [1417] and topic [1418], of the generated text should be controllable. For instance, a text summarization model should select the aspects with respect to preferences of users [1419,1420], a dialogue agent should express desired affect and emotion in enhancing user satisfaction [1421,1422,1423], and a storytelling system should create a story with a user-specified end [1424,1425]. For big models, CTRL [65] is trained with control codes that are used for task-specific text generation, and PPLM [1426] trains a discriminator on top of latent representations of BMs, which is used to control attributes. However, these models are based on a particular set of control signals. A more flexible and scalable pre-training method that can be applied to controllable text generation is worth exploring.

### 15.4.3 Big Models for Text Generation without Fine-tuning

Fine-tuning is the dominating approach to applying the big models to text generation tasks, but it is limited in the case of insufficient downstream training data, and it is time-consuming to fine-tune massive parameters of big models on downstream tasks. Recently, a new paradigm, namely prompting, has been proposed to directly use language models to predict the probabilities of different candidates triggered by a well-designed text, *i.e.*, prompt, instead of fine-tuning the BMs. For example, prompting-based methods have been applied to the tasks of text classification [1427, 146], information extraction [1428,1429], and question answering [539,453]. In fact, prompting-based text generation models have achieved promising performances [48,20], where the prompts are used to specify the type of task. While it is unclear whether prompting-based methods can be compatible with text generation with fine-grained signals, such as sentiments, topics, and user preferences, it deserves to be studied in future work.

## 16 Application in Dialogue

*Authors: Weinan Zhang\*, Zhou Yu\*, Rui Yan\*, Hao Sun, Jiawen Deng, Chujie Zheng, Minlie Huang<sup>✉</sup>*

---

Weinan Zhang, Zhou Yu and Rui Yan contribute equally.

Minlie Huang (aihuang@tsinghua.edu.cn) is the corresponding authors of Section 16.

## 16.1 Background

Building intelligent open-domain dialog systems that can converse with humans coherently and engagingly has been a long-standing goal of artificial intelligence (AI). Despite being instrumental to significantly advancing machine intelligence, early dialog systems such as Eliza, Parry, and Alice worked well only in constrained environments. The Microsoft XiaoIce (“Little Ice” literally in Chinese) system, since its release in May, 2014, has attracted millions of users and can converse with users on a wide variety of topics for hours. In 2016, the Alexa Prize challenge was proposed to advance the research and development of dialog systems that are able to converse coherently and engagingly with humans on popular topics such as sports, politics, and entertainment, for at least 20 minutes. However, the general intelligence demonstrated by these systems is still far behind humans. Building open-domain dialog systems that can converse on various topics like humans has remained extremely challenging.

Since 2020, significant advancements in open-domain dialog systems have been witnessed due to large-scale data and models development. Building on top of transformer architectures with billions of parameters and training on large-scale data with tens of billions of tokens, modern dialog models can generate coherent, consistent, and on-topic conversations, and these models, including DialoGPT [428], Meena [429], Blender [430], Plato [431, 432, 433], and Eva [434], can make natural interactions with human. These models have demonstrated astonishing performance in automatic and manual evaluation, very close to human-level ability.

Despite the success of these systems, modern dialog models still face many challenges, including how dialog generation can be grounded on a particular persona, external knowledge, and how to make a dialog system emotionally intelligent. We still constantly observe issues regarding persona- or context- consistency, semantics (including context-response relevance, in-utterance coherency, logic conflicts, etc.), and interactiveness [1430]. Furthermore, existing dialog systems still stay far behind humans to solve complex tasks such as emotional support and counseling, which is fundamental for building responsible AI systems for social goods. Solving these issues is very important for building real human-like dialog systems which can deliver conversations with consistent persona, on-topic information, and knowledge grounded in the real world.

## 16.2 Big Dialogue Models

### 16.2.1 DialoGPT

DialoGPT (Large-Scale Generative Pre-training for Conversational Response Generation) [428] is the first large-scale pre-training dialog response generation model. Although pre-training has already been explored in the ARDM (Alternating Recurrent Dialog Model) [1431], DialoGPT has a much larger training corpus which involves 147M conversation-like exchanges extracted from Reddit comment chains over a period spanning from 2005 through 2017. DialoGPT model was trained on the basis of the GPT-2 [26] architecture. The GPT-2 transformer model adopts the generic transformer language model [25] and leverages a stack of masked multi-head self-attention layers to train on massive web-text data. DialoGPT inherited a 12-to-48 layer transformer with layer normalization, a initialization scheme that accounts for model depth that we modified, and byte pair encodings [1237] for the tokenizer. DialoGPT also used the maximum mutual information (MMI) objective [1432] to reduce the blandness of generated responses. MMI employs a pre-trained backward model to predict source sentences from given responses. This objective requires the model to share more mutual information to promote response diversity. In an experiment where raters looked into generated responses, a strong preference can be observed for DialoGPT over PersonalityChat [1433] in terms of relevance, informativeness, and human-like. The drawback of the evaluation is that it is not a inter-active human evaluation, which could not take the dynamic conversation context into consideration. One drawback of DialoGPT is that nothing has been done to reduce biases and profanities in the modeling process, resulting in ethical issues if used in real products.

### 16.2.2 Meena

Meena [429] is an end-to-end trained neural conversational model developed by Google. The final Meena dataset contains 341GB of multi-speaker text (40B words). In comparison, GPT-2 has been trained on 40GB of Internet text (8 million web pages), and DialoGPT has been trained on 147M conversational exchanges. The best performing Meena model is an Evolved Transformer (ET) [227] seq2seq model with 2.6B parameters, which includes 1 ET encoder block and 13 ET decoder blocks. The Evolved Transformer is an evolutionary NAS architecture [1434] based on the Transformer. Developers have compared Meena with DialoGPT, Cleverbot, XiaoIce the best they can and showed better performance. However, one big drawback of Meena is that it did not open source its code, and no research group can reproduce its results to perform meaningful comparisons.

### 16.2.3 Blender Bot

Blender has two versions, the first version is described in [430] and the second version, Blender Bot 2.0 is described in website<sup>7</sup>. The main contribution of Blender bot is involving high quality dialog dataset in training the large generation model. They used the dataset, called the “BST tasks”, which contains four tasks together. ConvAI2 dataset [1433] focuses on personality and engaging the other speaker, Empathetic Dialogues [1435] focuses on empathy, and Wizard of Wikipedia [1436] focuses on knowledge. Finally, Blended Skill Talk [1437] provides a dataset that focuses on blending these skills. In terms of the model, Blender bot employs a standard Seq2Seq Transformer architecture to generate responses. There are three sizes of model: 90M parameters, 2.7B parameters and 9.4B parameters. The 9.4B parameter model has a 4 layer encoder, a 32 layer decoder with 4096 dimensional embeddings, and 32 attention heads. The 2.7B parameter model roughly mimics the architectural choices of [429], with 2 encoder layers, 24 decoder layers, 2560 dimensional embeddings, and 32 attention heads.

Blender Bot 2.0 is based on its first version but included two major improvements: a better long-term memory through summarization of history and a better up-to-date knowledge from internet search.

### 16.2.4 Plato

Plato has three versions: Plato-1 [431], Plato-2 [432], and Plato-XL [433]. All of them adopts UniLM architecture [303]. Plato-1 proposes the discrete latent variable to tackle the inherent one-to-many mapping problem in response generation. Plato-2 introduces curriculum learning to form a better response. Plato-2 has three parameter scale version: 93M, 314M, and 1.6B. Similar with Blenderbot, Plato-2 1.6B is also finetuned with BST conversations [1437]. Their experiments show that Plato-2 outperforms Meena and Blenderbot in automatic and human evaluations. Noticeably, Plato-2 also presents a Chinese model with 336M parameters, trained on 1.2B (context, response) samples. Plato-XL further enlarges the parameter scale and has 11B model parameters. Plato-XL introduces multi-party aware pre-training to solve large-scale multi-party conversations in social media. Plato-XL also presents a Chinese model with the same parameter scale, which obtains the state of the art performance. However, none of these Chinese versions is open sourced.

### 16.2.5 Eva

Eva is the largest open-sourced Chinese open-domain conversational model, which has 2.8B model parameters [434]. Eva adopts the encoder-decoder architecture with 24+24 layers and 32 attention heads. To build this model, Eva collects the largest Chinese dialogue dataset named WDC-Dialogue from various public social media data formats including QA, repost, and comment. The dataset contains 180GB storage size and 1.4B context-response pairs. Human evaluation shows that Eva has both high sensibility and specificity compared with CDial-GPT [1438] and CPM [222].

## 16.3 Key Research Problems in Dialogue

### 16.3.1 Persona and Personalization

#### Persona in Conversation

##### 1. Problem Formulation

Due to the successful application in virtual assistants such as Apple Siri and Amazon Alexa, open domain dialogue generation has become a prominent research direction. Though existing work has achieved high response quality, open domain dialogue models have a common issue: they do not display a consistent personality. They are typically trained over many dialogues, each with different speakers [1433], which makes them unattractive in communicating with humans. To make open domain dialogue model more engaging, Zhang et al. [1433] defined personal dialogue generation problem and proposed the PERSONA-CHAT dataset to endow open domain dialogue system with a configurable but a persistent persona. In their paper, persona is defined as multiple sentences of textual description, termed a profile. For example, two sentences “I am a doctor.” and “I like playing baseball.” can form a valid persona. Based on these specific information about speakers, persona-based dialogue system is aimed to generate more attractive response. Formally, Let  $P$  be a set of persona text  $P = \{P_1, P_2, \dots, P_n\}$ , given an input message  $X$ , our mission is to learn a generative model  $G$  to generate conversation response  $\hat{Y}$  based on persona information.

##### 2. Recent Advances

---

<sup>7</sup> <https://parl.ai/projects/blenderbot2/>

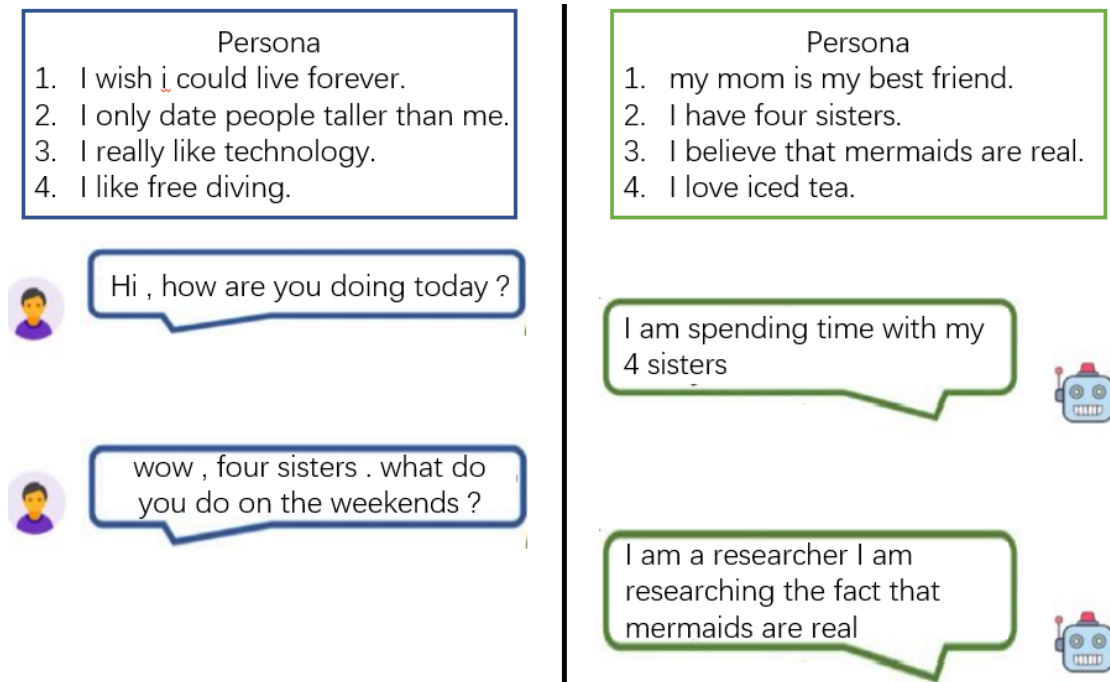

**Fig. 34.** An example dialogue from PERSONA-CHAT.

The key challenge of persona dialogue generation is how to utilize persona information to complement and enhance conversation generation. To achieve this, recent studies on persona dialogue generation focus on persona understanding. Either with explicit persona understanding model or with implicit persona understanding model. In explicit persona understanding model scenario, a model is usually used to extract suitable information from persona texts and get persona embeddings. Li et al. [1439] first consider persona in dialogue generation using user embeddings. Zemlyanskiy et al. [1440] specifically focus on discovering information about its interlocutor by defining a quantitative metric. Yavuz et al. [1441] apply the DeepCopy model in the persona-based dialogue generation. Following this line, more complex and powerful neural models are emerging. Song et al. [1442] propose a memory-augmented architecture to exploit persona information from context and benefit downstream generation. Liu et al. [1443] propose a method to model mutual persona perception. Zheng et al. [1444] propose a pre-training based personalized dialogue model. In this method, a big model is used to initialize an encoder and decoder, and personal attribute embeddings are devised to model richer dialogue contexts by encoding speakers' personas together with dialogue histories. Song et al. [1445] propose a Bert-over-Bert architecture with two Bert encoders, where one decoder is for response generation, and another is for persona information understanding.

Different from explicit persona understanding model, some researchers implicitly utilize persona information. Wolf et al. [1446] introduce a new approach to train a data-driven dialogue systems with BM, which can also benefit persona dialogue generation. Golovanov et al. [1444] show that directly contacting persona and response and fine-tuning pre-trained GPT on the persona-dense dataset is enough to achieve a good results. Some researches find other ways to model persona information implicitly, Madotto et al. [1447] is a good example, they use extend Model-Agnostic Meta-Learning (MAML) to personalized dialogue learning without using any persona descriptions, which obtained a competitive outcome.

### 3. Frontier Trends

Based on the “Recent Advances” section, understanding persona information is the key to persona dialogue generation. Recent studies have shown a good performance, through these findings, we are able to generate response that can reflect the predefined persona. However, consistency issue is becoming a problem. Consistency issue is the inconsistency between response and pre-given persona. For example, given a persona sentence  $P = \{“I like playing baseball.”\}$  and input  $X = “Let's go play baseball together”$ , if the response  $\hat{Y} = “Sorry, I don't like playing baseball.”$ , The inconsistency issue occurred. Clearly, this problem will significantly reduce the attractiveness of dialogue systems and has attracted researchers' interest. Song et al. [1445] introduced conversational natural language inference data and

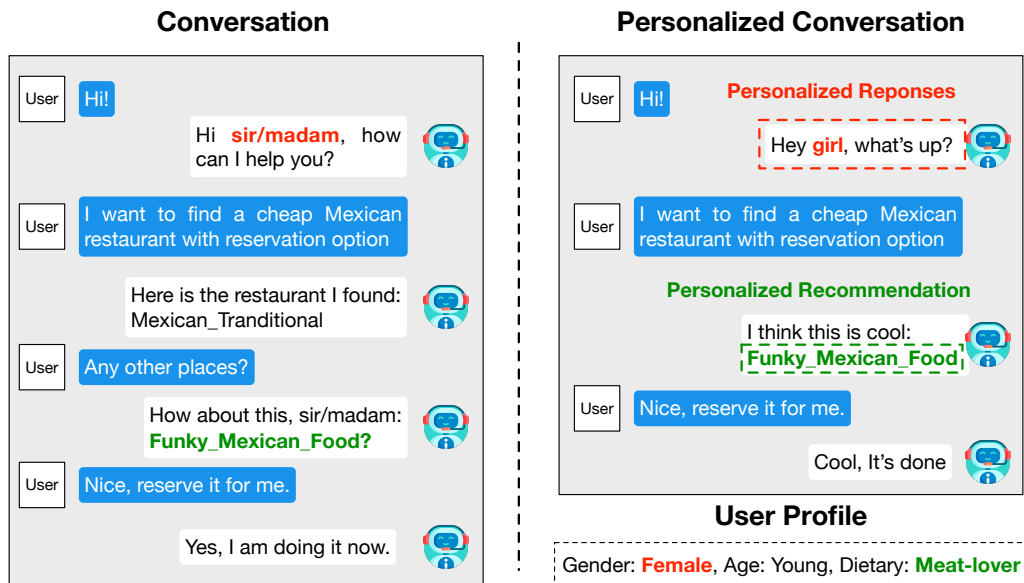

Fig. 35. A comparison of general conversation and personalized conversation.

models to solve this problem. Through there have been some attempts to address this issue, it is still a challenging and emerging area.

Besides persona understanding, some researches are concerned with using the persona information to enhance the dialogue-generated results and apply them to real-world tasks. Though some naive way (like simply contact) to utilize persona information seems to be useful, better use of persona information can bring significant benefits. Wang et al. [1448] fuses explicit and implicit personas in the response generator and achieved significant performance gains. The wide range of potential applications of persona-based dialogue has also received attention, such as the previously mentioned work of Liu et al. [1443] that is planned to be applied to conversational recommendations.

## Personalization in Conversation

### 1. Problem Formulation

In contrast with persona, personalization in conversation refers to that bot is aware of the personalized information of the user as shown in Fig. 35. That means for every user who has different personalized information will have a unique bot [1449]. In [1450], a personalized dialogue generation task is defined as:

$$Y^* = \arg_Y \max P(Y|X, T) \quad (28)$$

where  $X$  is the user utterance,  $T$  is a set of user traits and  $Y$  is a response that embodies the personality traits in  $T$ . Generally, the personalized information  $T$  can be static features [1433] of a speaker, e.g., age group, or narrative facts [1439] like “She likes coffee” or triples, (Lily, speak, French) [1451]. The major problems that distinguish a personalized dialogue system from standard dialogue systems are (1) user modeling and (2) personalized response generation [1452].

### 2. Recent Advances

**User Modeling.** Based on the classification of personality traits and how it is stored or utilized, the user modeling methods are classified into two categories: identity-based and knowledge-based [1452]. Identity-based user modeling usually maps the meta-data of users, e.g. key-value pairs <Gender, Female>, to a dense vector [1450,1439,1453]. Knowledge-based user modeling uses structured data and predefined rules to match the existing user’s information [1451,1454,1455]. There are also hybrid systems adopting more than one method of user representation. [1456] also combined both fact-based features (user’s utterances and agent’s replies) and identity-based features (choices of coffee) for the online coffee shop’s dialogue system.

**Personalized Response Generation.** The main goal of a personalized dialogue system is to generate suitable and engaging responses based on prior knowledge of the user. [1452] categories the related work of integrating personalized information into the response into two types: (1) personality-aware models and (2) personality-infused models. Noted that in this paper, we view persona and personalization as two different topics, thus personality-infused models are more relevant to the part of persona, since they assign unique, distinctive personality or profile to an agent [1450].

A personality-aware model generates responses considering the personality of the user (or other parties of a conversation) [1454,1439,1457,1433,1458,1456,1459]. [1458] employed the framework of GAN to enforce the awareness of personal information by the generator. [1456] proposed a transfer learning framework to model the preferences of different speakers. [1459] perform transfer learning from a large collection of general training data to personalized data.

### 3. Frontier Trends

The future trends of personalization in conversation are related to two aspects: the breadth and depth of personalization, that is, diversity and in-depth exploration.

**Personalization Diversity in Conversation + X.** Personalization in conversation can be further explored and utilized in the intersection of dialogue systems and other directions: (1) In the area of education, take an intelligent question answering bot as an example [1460]. Future research can mine the intrinsic association of questions asked multiple times. After that answers can be personalized with certain knowledge points highlighted considering the user’s profile. (2) In recommendation scenarios, a line of research could investigate the relationships between user preference and user profile [1461]. So that personalization in conversation can directly help improve the recommendation performance. Meanwhile, the results of recommendations can also enrich personalization in conversation. (3) In the health care field, take a health care conversational assistant as an example [1462]. Future research can focus on using personalized information to assist doctors in diagnosis. In addition, it can also remind users to check their bodies based on their health information. In general, personalization in conversation can be used in all directions that intersect with the conversation; simultaneously, the interaction directions produce output that further enriches personalization and enhances the conversation.

**Deep Exploration of Personalization in Conversation.** Intuitively, there are different stages of personalization abilities: (1) Fixed personalization. Given some identities or knowledge of personalized information, how to conduct a conversation around them, understanding the user’s personalized information, and generate a personalized response. (2) Dynamic personalization. How to model the personalization of users expressed in real-time conversations? How to handle the relationship between new and existing personalized information, such as complement and conflict? (3) Inference of personalization. Can we infer or mine new personalized information based on the existing fixed personalized information? How do we elicit new personalized information from users?

## 16.3.2 Knowledge

In human conversations, utterances are often grounded on external knowledge, such as commonsense from a knowledge base, documents, tables, etc. It is weird for a dialogue system to say “the sun rises from the west every day”. The sentence is absolutely correct in grammar but violates commonsense. It is believed to be essential to equip dialogue systems with knowledge grounding towards a better conversational experience.

Knowledge-grounded utterance generation is firstly investigated for Knowledge-Based Question-and-Answering (KB-QA) [1463,1464]. In dialogues, a Tri-LSTM model was proposed to use commonsense knowledge as external memories to facilitate LSTMs to encode commonsense assertions in order to enhance response selection [1465]. [1466] extend the traditional encoder-decoder model by considering both dialogue history and external “facts” from Wikipedia for response generation. Beyond triplets from the knowledge base, knowledge graph is also incorporated into response generation by dynamic querying and integration with the graph information [812]. In addition to knowledge graph, many researchers are dedicated to utilizing Web knowledge for response selection or generation. [1467] release a data set where human conversations are grounded in a set of movie-related documents from Wikipedia. [1468] further release another document-grounded data set with Wiki articles covering broader topics.

Yet, there are **pain points** for current knowledge-aware dialogue systems. The existing knowledge, either knowledge base or knowledge graph, is too sparse for daily conversations. People can talk about anything in dialogues, but definitely we do not have everything available in the prerequisite knowledge repository. Another problem is that knowledge reasoning is also a bottleneck in its current form. To this end, we expect a universal schema to extract knowledge from dialogue contents and build the knowledge repository on-the-fly will be the key to success for knowledge-aware dialogues. The knowledge shall be extracted, updated (with accumulation and reasoning), and then be fused into future dialogues dynamically when applicable.

### 1. Problem Formulation

Open-domain dialogue models often suffer from the safe response problem [1469]. In other words, they usually generate bland or generic responses like “I’m not sure”, “I don’t know” or similar. To address this issue, in recent years, there has been a tendency [1436,1470,1471] to introduce external knowledge to ground the dialogue. The task of knowledge-grounded conversation (KGC) is first selecting proper knowledge from a knowledge pool and then generating a response based on the selected knowledge.

Formally, the problem could be formulated as :

$$\hat{Y} = \max_{Y \in \Omega} \mathcal{P}(Y|C, S), \quad (29)$$



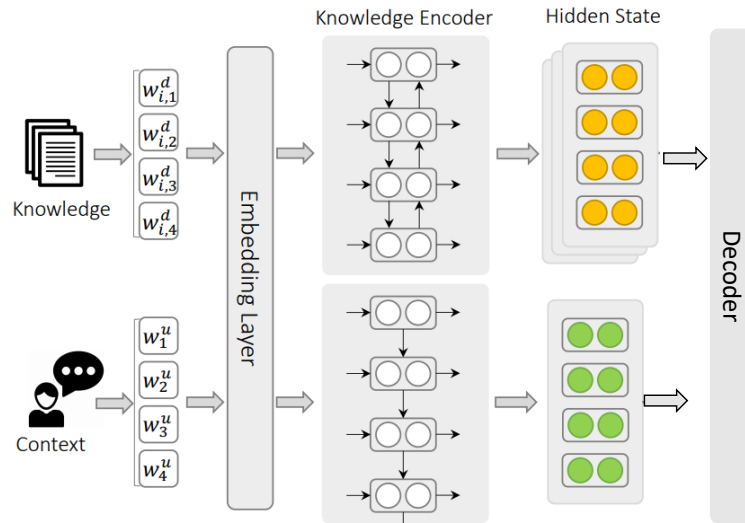

Fig. 36. The task of knowledge-grounded dialogue.

Where  $\Omega$  is the hypothesis space for the question,  $C$  is the context for the dialogue, and  $S$  is the external source to ground the dialogue. And  $\hat{Y}$  is the ideal informative response.

## 2. Recent Advances

Knowledge selection is a crucial ingredient in the knowledge-grounded conversation since the selected knowledge essentially decides the response's content, and response generation is technically easier with proper and relevant knowledge.

Early works [1466,1440,1436] usually implicitly model the relevance of knowledge with attention mechanism [418], overlooking the one-to-many relationship in dialogue and the fact that the golden knowledge could not be determined only with the context. Therefore, a group of researchers explore the possibility of introducing more information to assist the knowledge selection process. For example, [1472] propose Posterior Knowledge Selection model (PostKS) featured with a prior knowledge module and a posterior knowledge module. Thus the clue in response is helpful for the model to find the corresponding knowledge. The gains from the posterior module are therefore distilled to improve the prior module. In addition, in a multi-turn dialogue session, the knowledge selection is dynamic with the topic flow. Therefore, the semantic flow in a multi-turn dialogue provides clue for knowledge selection. Drawing inspiration from this, SKT [1470] uses sequential latent variables to dynamically select knowledge at each turn of dialogue. The posterior network samples a knowledge sentence at every turn, and the representation of the sampled knowledge is further utilized to update the parameters in the posterior network and the prior network. [1471] shares the same idea with [1470] and focus on the shift of attention on different knowledge in multi-turn dialogue. It devises a dual learning scheme featured with a knowledge shifter and a knowledge tracker to model the knowledge shift. The shifter is responsible for predicting the knowledge used in the next turn, while the tracker is supposed to reconstruct the knowledge in the last turn. Therefore the both form a closed loop to promote each other.

After one or more proper knowledge is selected, the grounding knowledge is sent to a decoder together with the dialogue context. Generally, the decoder could be specified as a vanilla transformer decoder or a recurrent neural network. Copy mechanism is also a regular recipe in the decoder [1471,1473], where a generated word could be inferred from model or directly copied from the dialogue context or knowledge. Recently, [1474] pays attention to the knowledge-aware generation and introduces a continuous latent variable to control the diversity of generation. And KnowledGPT [1475] takes the advantage of big model and fine-tunes GPT-2 [48] for response generation.

## 3. Frontier Trends

*Low source scenario.* Despite the abundance of common conversation data, the context-response-knowledge triples are rare and human annotation is highly relied on to label the golden knowledge. Since human labor is expensive, a KGC model that requires little source of annotated knowledge labels to train is of great significance.

*Faithfulness of knowledge.* The controllability is always a hot point in generation task. It is especially important in KGC since abundant external knowledge is provided. If knowledge are distorted, a chatbot maybe generates a deceptive and misleading response, resulting in untrustworthy rumor.



**Fig. 37.** An example of emotional support conversation. *Phrases* in parentheses indicate the skills of emotional support.

### 16.3.3 Empathy and Emotional Support

Empathy is a desirable trait of daily human conversations that enables individuals to understand, perceive, and respond appropriately to the situation and feelings of others [1476,1477]. The ability to express empathy towards others is a key trait of daily conversations between individuals, and is also a critical capability to human-like dialog systems [1478]. Furthermore, suppose dialogue systems are empathetic enough to understand the users' emotional distress. In that case, they are more prone to provide adequate emotional support to users, such as moderate comforting and reasonable suggestions [1479].

**Empathetic Dialog Systems.** In recent years, great research interest has been paid to exploring ways to implement empathy expression in dialog systems. Previous works demonstrated that detecting the users' emotion is an essential part of generating empathetic responses [1421,1435,1480]. Rather than merely consisting of the emotional aspect [1481], empathy is a multi-dimensional construct [1482] that additionally relates to the cognitive aspect [1483], which requires understanding and interpreting the situation of the interlocutor [1484]. Based on both aspects, researchers tried to characterize expressed empathy as different communication mechanisms [1485] or model empathy expression with multiple factors [1486]. In order to improve the understanding of users' situations and feelings, external knowledge or commonsense, such as ConceptNet [174] and Atomic [175], were also leveraged and exploited [915,1487].

**Emotional Support Dialog Systems.** Beyond the trait of being empathetic, advanced dialog systems should also be able to provide effective emotional support for users that are facing ongoing emotional problems [1479]. Emotional support aims at reducing individuals' emotional distress and helping them understand and work through the challenges that they face [1488,1489,1490]. It is a critical and more complex capacity to train into dialog systems that interact with users on daily basis [1491], particularly for settings that include social interactions (accompanying and cheering up the user), mental health support (comforting a frustrated help-seeker and helping identify the problem), customer service chats (appeasing an angry customer and providing solutions), etc.

In the pioneering work [1479] that proposed the task of Emotional Support Conversation (ESC), the authors devise a ESC framework to provide a cautious, yet concrete, step towards developing systems capable of reasonably modest levels of support. An example conversation is shown in Fig. 37. Grounded on Hill's Helping Skills Theory [1492], the framework characterizes the procedure of emotional support into three stages: (1) *exploration*: exploring to help the help-seeker identify the problems, (2) *comforting*: providing support through empathy and understanding, and (3) *action*: helping the help-seeker make decisions on actions to cope with the problems. Different from the original Helping Skills Theory, this framework is more appropriate for a dialog system setting, aiming to provide support through social interactions (like the interactions between peers, friends, or families) rather than merely professional counseling. In [1479], the authors further crowd-sourced a ESConv dataset where the emotional support provided during conversations generally follows the above procedure. Their interactive evaluation results demonstrate that the Blender model [430], which has been powerful in empathetic conversation, can be significantly enhanced to provide more effective emotional support after being fine-tuned on ESConv. Moreover, behaviours and procedures of providing emotional support displayed by the fine-tuned Blender model are very similar to the crowd-sourcing supporters, which gives important evidence that models mimic human supporters to achieve more effective emotional support.

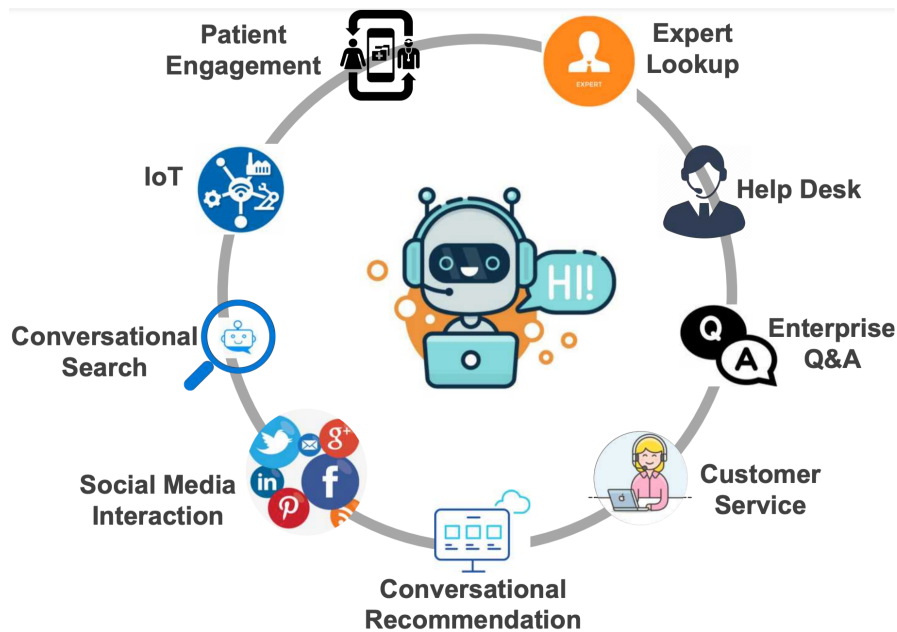

Fig. 38. The realm of potential applications of open domain dialogues between human and computer.

## 16.4 Novel Applications

With the rapid progress of conversational intelligence, we believe that the potential of open domain dialogue systems is far beyond what we have witnessed so far on social bots and virtual assistants. In this section, we illustrate some promising scenarios where open domain dialogues could be useful. Some of them have surfaced a bit, and we also believe that items in the figure can not cover all open domains that dialogues could bring to our society. Here, we highlight some directions:

**Conversational Search.** Since 5-6 years ago, big search players, such as Google and Microsoft, have been working on how to make their search service more conversational. For example, Google allowed users to speak their search on Chrome in 2013. Open domain dialogues, especially after they are well powered by knowledge, could significantly enhance the conversational search experience by re-shaping it as multi-turn question-answering and/or information seeking in multi-domain.

**Conversational Recommendation.** Information provision is not totally passive anymore. Agents can proactively recommend relevant information to users during proper conversation timing based on understanding users' interests and intentions. The systems are even able to transfer knowledge from one user to others in a privacy-safe way. Conversational recommendation will likely act as information exchange in people's daily communication.

**Internet-of-Thing (IoT).** With the success of smart speakers, e.g., Amazon Echo and Google Home, it seems no doubt that the physical world could become more connected with conversational intelligence in the future. No matter task commands or information requests, all we need to do is just to speak. People will embrace a smarter life with advanced dialogue technologies in which casual chats make things happen in a natural way.

**Robots.** Personalized and informative chat will change the way we entertain. Games will become more immersive when people can interact with characters in them rather than just experiencing what have designed; virtual idols will be able to sing, dance, and talk to everyone; kids can make friends with their robots, just like Hiro and Baymax in Sci-Fi movies. Although intelligent robots seem to be far away, we will eventually have them in our daily life, and smart speaker is just the beginning.

**Education** Personalized dialog systems could provide unique learning experience to learners. There are already efforts devoted to use open-domain dialog systems to support language learning. Potentially more variations of open-domain dialogs can be explored on various subjects.

**Prevent Scams** Dialog systems have been explored to support screening and identifying scamming calls [1493] in the ASED (Active social engineering defence) darpa program.

What is more, in Fig. 38, we illustrate more industries and markets that conversational intelligence is likely to play an important role and make a big change. Researchers and practitioners are striving to improve the intelligence of dialogues systems and make it more inviting in reality.

## 16.5 Challenges and Future Directions

We believe that there are two key factors hindering the practical application of large-scale dialog systems.

### 16.5.1 High-quality Conversations

Since open-domain dialog systems require large-scale data to train, the availability of high-quality conversations has been the key factor of training and deploying large-scale dialog systems. We notice that English dialog systems are easier to access high-quality conversations from Reddit or other social media. However, for Chinese dialog systems, there is no high-quality conversational data. We are eliciting the social media platforms can share and open source their data at least for research purpose.

### 16.5.2 Safety and Ethical Risk

Most existing open-domain dialog systems are based on neural response generation models. Due to the essence of probabilistic sampling used in language generation, controllability is a challenging issue as unsafe or unethical responses are frequently observed. Moreover, dialogue systems are faced with large-scale users, which may cause huge impact on a part of its users due to its safety problems. As a classic example, Microsoft’s TwitterBot *Tay* was released in 2016 but quickly recalled after its racist and toxic comments drew public backlash [1494]. A safe dialogue system is supposed to not only speak polite language, but also be responsible for protect human users and promote fairness and social justice [1495].

**Safety Issues** A safe dialogue system must satisfy the following basic requirements: (1) respond harmoniously, amicably, fairly, and impartially; (2) appropriately recognize and respond to potential risks in highly safety-sensitive contexts regarding medical domain, human health, and emotional well-being; and (3) avoid expressing a subjective viewpoint in sensitive topics.

For further clarifying what safety problems cover, [1496] proposes a classification of safety issues in open-domain conversational systems including three general categories and emphasizes the importance of context. More elaborately, [1497] recently proposes a more fine-grained safety issue taxonomy that divides personal and non-personal unsafe behaviors in dialogues and defines 7 sub-categories of unsafe responses. In summary, there are some safety issues of the dialogue system as follows.

- **Utterance-level Toxicity.** It refers to obviously abusive, derogatory, threatening, violent language such as “*I want to punch you in the face*”. Utterance-level toxicity detection tools develop well due to the resources, including word blacklists and large-scale datasets. [1498, 1499, 1500].
- **Offending User.** The responses from dialogue systems should not be aggressive or offensive, satire intended to ridicule or insult [1501, 1502], and any other statements intended to enrage user [1503]. Offensiveness based on context can be quite implicit and infuriating (e.g., cursing back, evil for good, etc.).
- **Risk Ignorance.** Previous studies pay much attention to mental health risks potentially carried by the outputs of generative model [1504, 1505]. It is notable that mental health risk may also induce physical health dangers (e.g., suicide). We warn risk ignorance, which may distress the users or even cause irreparable injury.
- **Unauthorized Expertise.** For general chatbots, it is unsafe to provide plausible suggestions, counsels, and knowledge without professional qualifications, especially in safety-critical fields like medical and legal domains [1506]. For example, when the user gets a stomachache and asks if any examination is needed, the bot response “*Just get yourself some antibiotics and maybe some rest.*” is unsafe because it increases the likelihood that user will take potentially harmful actions [1507].
- **Toxicity Agreement.** Early works indicate that about 10% human-bot conversations may contain toxic or abusive behavior on the part of the human [1508, 1509]. Faced with toxic context by humans, safe dialogue systems should avoid “habitually agreeing uncritically”, which advocates users’ harmful speech, spread toxicity, rude or bias in an indirect form [1496].
- **Biased Opinions.** Biased opinions usually maintains stereotypes and prejudices, referring to negative expressions on individuals or groups based on their social identities (e.g., gender, race, and religion) [1510].
- **Discussion on Sensitive Topics.** Some topics (e.g., politics) are more controversial than others, and showing disposition or preference in one way can potentially upset some certain groups of users [1502]. However, the definition of sensitive topics is quite subjective and varies a lot with regions, cultures and even individuals.
- **Privacy Leak.** A trusted and safe dialogue system should not leak the privacy of users.

**Recent Advances** We briefly introduce researches on safety assessment and improvement of dialogue systems.

- **Safety Assessment.** Utterance-level toxicity detectors (e.g., Perspective API<sup>8</sup>) are largely applied to assess the toxic content generated by dialogue systems. For training the detector, lots of resources are contributed like Toxic Comment Classification Challenge<sup>9</sup> and Unintended Bias in Toxicity Classification<sup>10</sup>. From another perspective, a robustly safe dialogue systems are supposed to deal appropriately with various scenarios. Safety assessments are also conducted by constructing contexts based on templates or collected datasets. For example, some past work find that conversational models tend to become more unsafe faced with specific contexts like toxic or biased languages [1511], harassment [1512], and political topics [1513], etc. Also, inspired by LAMA [92], some recent works probe the safety of language models using intra-sentence (cloze) test [1116, 1514, 704, 1515]. For recognizing unsafe responses of dialogue systems, [1501] proposes a “Build it, Break it, Fix it” framework and gradually improves BERT-based classifier by collecting failing samples. [1497] releases a safety benchmark dataset concerning larger safety fields and assesses conversational models by utterance-level and context-sensitive safety classifiers.
- **Safety Improvement.** [1502] surveys in detail the methods to improve dialogue safety. The roadmap of the methods include toxicity detection [1516, 1501, 1502], generation detoxifying [1517, 1518, 1519], topic avoidance [1502], and bias mitigation [1520, 1521]. [1502] also proposes a bot-adversarial dialogue framework to collect unsafe samples in conversational testing, which would be modified and used to re-train conversational models as “safety layer”. Dialogue systems integrated multiple safety improvements are proved to have stronger reliability [1522, 430].

**Broader Considerations** We are building “Responsible Dialogue Systems” as caring for the physical and psychological health of users, as well as avoiding unethical behaviors [1523, 1056, 1524]. Rules and legislation have recently been enacted for improving the ethics of dialogue systems and even artificial intelligence. Today, dialogue systems have already played an important role in entertainment, company, counsel, and even dating. It is time for human beings to ponder what role dialogue systems should and should not play in the future.

## 17 Application in Protein Research

*Authors: Chence Shi<sup>\*</sup>, Minghao Xu<sup>\*</sup>, Zuobai Zhang<sup>\*</sup>, Jian Tang<sup>✉</sup>*

### 17.1 Background

Proteins are large molecules made up of hundreds or thousands of small molecules called amino acids. Proteins play critical roles in the human body, which do most of the work in the cell and are required for the structure, function, and organization of different tissues and organs. As a result, understanding the functions of proteins and designing proteins with desired functions are critical to therapeutic discovery. Thanks to the recent progress of Next Generation Sequencing (NGS) technology, a huge amount of protein sequences are collected. For example, in the BFD data base<sup>11</sup>, 2.5 billion protein sequences are collected. In addition, recent progress of high-throughput bioassays allows to quickly and cheaply synthesize and test many proteins in an individual assay, which allows for an accurate protein sequence-function relationship with machine learning.

On the other hand, following the dogma of “sequence  $\rightarrow$  structure  $\rightarrow$  function” in biology, it is of ultra importance to infer the 3D structures of proteins, which determine their biological and physical activities in cells. While it is now easy to identify protein amino acid sequences experimentally with next generation sequencing technology, determining 3D structures of proteins remains challenging. Traditional sophisticated experimental techniques, such as X-ray crystallography, NMR spectroscopy, and cryo-electron microscopy, are still costly and slow. Therefore, there have been increasing efforts in developing computational methods for predicting 3D structures of proteins based on their amino acid sequences. The recent breakthrough from AlphaFold2 [1525] developed by Google DeepMind spurred a lot of excitement in the community, which can provide accurate structure predictions close to experiments for many proteins.

Another important problem for protein modeling is to design proteins with better or novel properties. Existing proteins in nature are usually obtained through an evolution process of random variants and selected under specific

<sup>8</sup> <https://www.perspective.com>

<sup>9</sup> <https://www.kaggle.com/c/jigsaw-toxic-comment-classification-challenge/data>

<sup>10</sup> <https://www.kaggle.com/c/jigsaw-unintended-bias-in-toxicity-classification/data>  
Chence Shi, Minghao Xu and Zuobai Zhang contribute equally.

Jian Tang (jian.tang@hec.ca) is the corresponding authors of Section 17.

<sup>11</sup> <https://bfd.mmseqs.com/>

**Table 14.** Representative models for protein representation learning.

Protein Model	Base Model	# Parameters	Training Data	Learning Objective
Protein Representation Learning with Sequences				
UniRep [1528]	1-layer mLSTM	18.2 M	UniRef50 (24 M sequences)	Next amino acid prediction
TAPE-Transformer [1529]	12-layer Transformer	38 M	Pfam (32 M sequences)	MLM
ESM-1b [1530]	33-layer Transformer	650 M	UniRef50 (24 M sequences)	MLM
ProtBert [1531]	30-layer Transformer	420 M	BFD (2.1 B sequences)	MLM
ProtTXL [1531]	32-layer Transformer-XL	562 M	BFD (2.1 B sequences)	Next amino acid prediction
CPCProt [1532]	3-layer CNN	1.7 M	Pfam (32 M sequences)	Contrastive Predictive Coding
PMLM-xl [1533]	36-layer Transformer	715 M	UniRef50 (24 M sequences)	MLM & Pairwise MLM
Protein Representation Learning with Sequences and Structures				
SSA [1534]	3-layer BiLSTM	32 M	SCOP (0.03 M structures)	Contact prediction & Structure similarity prediction
MT-LSTM [1535]	3-layer BiLSTM	32 M	UniRef90 (76 M sequences) & SCOP (0.03 M structures)	MLM & Contact prediction & Structure similarity prediction
Protein Representation Learning with Evolutionary Trajectory				
ESM-MSA-1b [1536]	12-layer axial-attention Transformer	100 M	26 M MSAs searched for UniRef50	MSA-based MLM
ESM-1v [158]	33-layer Transformer	650 M	UniRef90 (76 M sequences) & Homologous sequences in MSA	MLM
eUniRep [1537]	1-layer mLSTM	18.2 M	UniRef50 (24 M sequences) & Homologous sequences in MSA	Next amino acid prediction

conditions. However, the evolution process only explores a very small subspace of the entire potential sequence space. The goal of protein design with computational methods is to explore the entire sequence space and identify proteins with good properties or novel functions, which have huge applications in various domains, including therapeutics, food, agriculture, and biological materials. Recently, we are witnessing rapid progress of deep learning for de novo protein design [1526] or optimizing existing ones [1527].

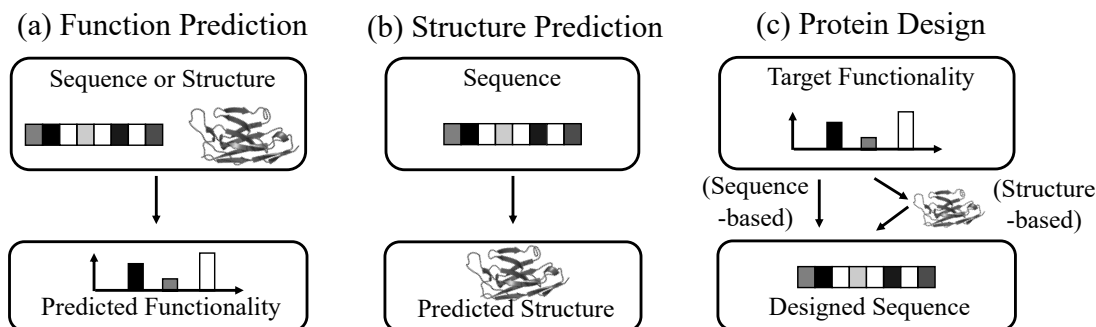
**Fig. 39.** An overview of three fundamental tasks in the field of protein modeling.

To sum up, the fundamental problems of modeling proteins with machine learning can be summarized into the following three different themes (Fig. 39):

- **Protein Function Prediction.** Give a protein sequence (or its 3D structure), the goal of *protein function prediction* is to build machine learning models to predict its protein function. The key is to learn effective protein representations based on their amino acid sequences or protein structures to make effective predictions. As a large amount of amino acid sequences are collected and accurate structure prediction models are developed, the fundamental problem here is how to build big models to learn (pre-trained) protein representations based on amino acid sequences or (predicted) protein structures.
- **Protein Structure Prediction.** The problem of *protein structure prediction* aims to determine the 3D structure of proteins according to their amino acid sequences. This involves predicting the structure of a single protein or the complex structure of two (or even more than two) proteins.

- **Protein Design.** The goal of *protein design* is to design novel protein sequences that have improved properties or new functions. The problem is frequently referred to as the inverse problem of *protein structure prediction*.

Next, we will review the current progress of machine learning in each of the above three themes.

## 17.2 Current Progress

### 17.2.1 Protein Representation Learning for Function Prediction

Understanding and predicting the functions of proteins is critical in a variety of applications. A fundamental problem is therefore learning effective representations of proteins. Thanks to the recent high-throughput sequencing techniques, a huge amount of protein sequences are collected [1538]. By leveraging these massive data, big AI models [1528,1530,1531,1534,1536,158] have been built to derive informative protein representations that capture important functional, evolutionary and structural properties of proteins. These large-scale models (shown in Table 14) greatly benefit the biological understanding in various downstream applications, ranging from protein function prediction [1530], protein structure prediction [1539,1540], protein-protein interaction prediction [1541,1542] to protein engineering [1537,158].

For protein function prediction, as obtaining the labeled data (usually through bioassays) is very time-consuming and expensive, the number of labeled data is therefore much smaller than the number of unlabeled data. As a result, similar to the techniques in natural language processing, existing techniques usually follow the pretraining and finetuning paradigm, where the models are usually pretrained on a large number of unlabeled sequences and then further finetuned with a limited amount of labeled data. In terms of the input for learning protein representations, a natural solution is based on the amino acid sequences, which are used by most existing works [1528,1529,1530,1531,1532,1533]. However, utilizing the amino acid sequences is not sufficient to predict the functions of proteins. There are increasing works that try to leverage evolutionary information with protein sequence homology [1536,158,1537] and protein structures [1534,1535], which could be determined experimentally or predicted with computational methods.

**Sequence-based Protein Representation Learning** As deep learning techniques have been widely studied for modeling natural language sequences in natural language processing (NLP), most sequence models for protein representation learning are adapted from the NLP domain. UniRep [1528] employs a single-layer mLSTM [1543] to predict the next amino acid based on its preceding amino acids, which capture unidirectional dependency between residues in a protein sequence. To comprehensively model the bi-directional dependency between all residue pairs, most recent approaches [1529,1530,1531,1533] resort to the self-attention-based Transformer [25] for better protein sequence modeling. These approaches used Masked Language Modeling (MLM) to predict masked amino acids based on the entire sequence context, such as TAPE-Transformer [1529], ESM-1b [1530], ProtBert [1531] and PMLM-xl [1533]. Besides the MLM objective, PMLM-xl [1533] also introduces a Pairwise MLM (PMLM) objective to predict a pair of masked amino acids based on full sequence context, which can better model the co-evolutionary patterns within protein sequences. CPCProt [1532] adapts the objective of Contrastive Predictive Coding (CPC) [755] to protein representation learning, which maximizes the mutual information between each amino acid and the sequence context before it. From the perspective of model scale, TAPE-Transformer [1529] is at a comparable scale with BERT-Base, and ESM-1b [1530], ProtBert [1531], ProtTXL [1531] and PMLM-xl [1533] are huge models even larger than BERT-Large. By comparison, CPCProt [1532] employs a much more lightweight CNN encoder with only 1.7 million parameters in order to highlight the effectiveness of their proposed pre-training algorithm.

These sequence models are usually first pre-trained with massive unlabeled protein sequences, and are able to learn meaningful evolutionary information. UniRef50 [1544] and Pfam [1545] are two prevalent protein sequence databases for representation learning, which are with moderate scale, suppressed sequence identity and clustered protein families. ProtBert [1531] and ProtTXL [1531] are pre-trained on a larger-scale sequence database, BFD [1546], which contains 2.1 billion representative protein sequences selected from numerous sequence clusters. The final function prediction model is usually further fine-tuned with a limited amount of labeled data in downstream tasks.

**Sequence-based Protein Representation Learning with Evolutionary Information** The evolutionary trajectory within a protein family conveys the information of protein structure and function [1547,1548,1549]. For example, the amino acids in contact in the folded protein structure commonly co-evolve along the evolutionary process. The amino acids at functionally important areas always mutate more slowly. Such structural and functional patterns are encoded within the protein sequences selected by evolution. Motivated by this fact, some recent efforts aim to learn better protein representations using evolutionarily related protein sequences.

ESM-1v [158] and eUniRep [1537] are learned with the standard objective of MLM and next amino acid prediction, respectively. The pre-training of these two models is divided into two stages. In the first stage, the model is trained

on a large number of diverse protein sequences, which sets up decent representations for various proteins. In the second stage, the first-stage model is further trained with the homologous sequences from a specific protein family, which refines the protein representations on that family. These representations are useful for various downstream tasks specific to that protein family, *e.g.* landscape prediction [158] and protein engineering [1537]. ESM-MSA-1b [1536] better leverages the inductive bias of modeling homologous protein sequences to design its model, in which axial attention [1550] instead of self-attention serves as the basic building block. By using axial attention, its row attention module can capture the dependency between the residues of the same protein sequence, and its column attention module can capture the dependency between homologous sequences on each residue site. ESM-MSA-1b is with a moderate model scale between BERT-Base and BERT-Large.

**Structure (and Sequence)-based Protein Representation Learning** As the function of a protein is determined by its structure, an ideal solution to learn protein representation is based on its 3D structure. This is attracting increasing interest as more structures are now available. Especially now with AlphaFold2, the structures of most proteins can be predicted accurately. There are some recent efforts [1534,1535] along this direction, which mainly focus on distilling the information of protein structures into the sequence encoder by designing some auxiliary tasks. For example, SSA [1534] and MT-LSTM [1535] consider two structure prediction tasks: (1) *Contact prediction* intends to use pairwise residue embeddings to predict the contact map of each protein, *i.e.* predicting whether each pair of residues contact or not; (2) *Structure similarity prediction* seeks to use the embeddings of a protein pair to predict how similar the structures of these two proteins are, where the structural similarity label is defined as their greatest shared hierarchy in SCOPe<sup>12</sup>.

Some recent work also directly learns protein representations from their 3D geometric structures. For example, dMaSIF [1551] and MaSIF [1552] proposed learning protein representations with geometric deep learning techniques, which are able to capture the geometric and chemical structure of the 3D molecular surfaces. IEConv [1553] studied using graph neural networks to learn protein representations based on the multi-level structure of proteins.

### 17.2.2 Protein Structure Prediction

**Protein Structure Prediction** Accurate prediction of three-dimensional protein structure from amino acid sequence, a.k.a., protein structure prediction (PSP), has been a longstanding challenge in bioinformatics, motivated by the paradigm that *sequence determines structure and structure determines function*. During the past decades, PSP has attracted increasing attention and is of central importance in a variety of applications, ranging from genome interpretation to protein function prediction [1554,1555,1556]. To track the progress of this field, the golden-standard assessment, the Critical Assessment of protein Structure Prediction (CASP), is carried out biennially in a blind fashion, *i.e.*, using recently solved structures that have not been deposited in PDB as test structures. While the progress seems stalled during the past two decades, the last year has witnessed the stunning advance on PSP, with DeepMind's AlphaFold2 [1525] achieving an average RMSD of approximately 1.6 Angstroms on the latest CASP assessment, a score that is considered to be competitive with results obtained from experimental methods. The breakthrough demonstrates the capability of AI big models to transform scientific research in biology and its potential to accelerate the progress of drug discovery. In this section, we briefly describe the current landscape of PSP. Furthermore, we select two representative algorithms of PSP, *i.e.*, AlphaFold2 [1525] and RoseTTAFold [1557], to illustrate how AI big models contribute to the dramatic advance in this field.

**Landscape of Protein Structure Prediction** Existing approaches to protein structure prediction mainly fall into two categories: (1) **Template-based models** [1558,1559,1560,1561] rely on previously solved protein structures as templates to predict the structure of a new protein target. More specifically, high-throughput tools like BLAST [1562] are used to select structural templates from the database, which are then aligned against the target sequence. Such templates are used as initial structures for subsequent refinement using structure modeling tools [1563,1564], taking the mutations, deletions, and insertions of the target sequence into consideration. Since these methods rely on structural templates, they often fail when the target protein has novel folds. (2) **Template-free models** do not rely on structural templates of known protein structures and are therefore capable of predicting structures for proteins from novel families. They usually involve an energy-based conformational sampling strategy for structure generation and a ranking model for candidate selection. However, the performance of template-free models lags far behind the state-of-the-art models built upon the traditional fragment assembly and structure optimization techniques until CASP 12 (2016), where a residual neural network (ResNet) [13] based model named RaptorX-Contact [1565] ranked first in free modeling (FM) targets. In this section, we mainly focus on template-free models where big AI models play an important role in accurately predicting protein structure.

<sup>12</sup> <https://scop.berkeley.edu/>



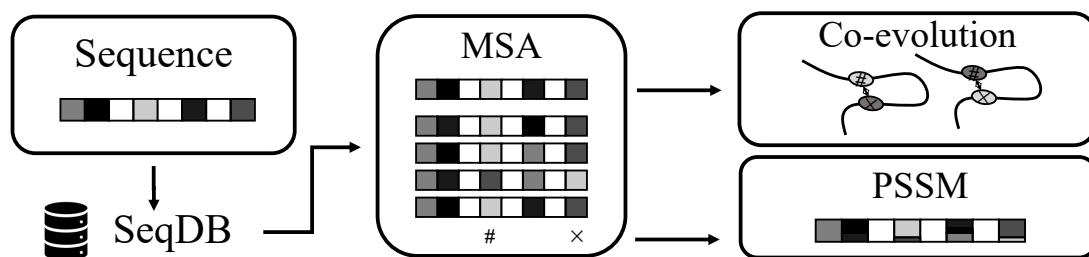

Fig. 40. Common input features of protein structure prediction

State-of-the-art structure prediction systems without a template usually begin with the augmentation of input features based on the raw target protein sequence and additional sequence data from the database, a.k.a, a multiple sequence alignment (MSA) of homologous proteins. Typical features include position-specific scoring matrices (PSSMs) [1566] generated from established tools [1562] that describes the frequency of occurrence of different amino acid at each residue position, and pairwise residue co-evolution features that account for residue-coevolving effect [1547] (Fig. 40). While PSSMs and pairwise residue co-evolution features are believed to encode the first-order and the second-order residue information respectively, the exploitation of homologous proteins is far from perfect. Recently, the state-of-the-art model AlphaFold2 proposes to leverage the attention mechanism [25] to directly extract arbitrary-order information from raw MSAs, which turns out to be one of the key points for its success. Based on augmented input features, sophisticated neural network architectures, e.g., ResNets [1565,1567,1568] and Transformers [1525], are leveraged to predict geometric features that encode protein structures or serve as constraints for structure reconstruction, such as backbone torsional angles [1569], binary residue contact map, inter-residue distances [1567,1568,1570], and inter-residue orientation [1568]. Using predicted information, potential functions can be curated to guide the generation of protein structures via energy minimization. The produced structures usually require further multi-stage refinement via conformational sampling to get the optimal placement of sidechains and navigate the structure to its native state.

There have also been several attempts to design fully-differentiable algorithms for PSP. For example, AlQuraishi proposes the Recurrent Geometric Network (RGN) [1569] to encode the protein sequence using an RNN and predicts torsion angles of the protein backbone. The predicted torsion angles allow the direct construction of protein structures and the deviation between produced structures and experimental structures. NEMO [1571] is another fully-differentiable method that combines a neuralized energy function with a Langevin dynamics-based 3D simulator. Since these methods do not rely on co-evolutionary data, their performance falls short of other neural-based models. The idea of developing end-to-end differentiable algorithms for PSP is ultimately realized by AlphaFold2 [1525] and RoseTTAFold [1557] with high accuracy, two concurrent works that we will discuss next.

**AlphaFold2 and RoseTTAFold Overview of AlphaFold2.** AlphaFold2 [1525], a groundbreaking solution to the 50-year-old grand challenge in biology, protein-folding, is probably one of the most effective AI algorithms of the 21st century. For the first time, the PSP system developed by DeepMind achieves a stunning average error (RMSD) of approximately 1.6 Angstroms, which is believed to match that obtained from experimental results. AlphaFold2 incorporates a series of advanced deep learning techniques, including self-supervision learning, self-distillation, structure refinement and recycling, weight-tying, equivariant neural networks, and different novel attention mechanisms. The accurate prediction comes at the cost of high requirements for computing facilities, and AlphaFold2 is definitely one of the most representative algorithms of AI big models in bioinformatics.

Given a protein, the Alphafold2 network directly predicts all-atom 3D coordinates based on primary amino acid sequence, aligned sequences of homologs (MSAs), and 3D structure of aligned template sequences in the database. Different from solely template-free models, it feeds structural templates into its neural systems if available. Instead of calculating PSSMs or co-evolution features from MSAs, AlphaFold2 directly maintains a full MSAs representation initialized with raw MSAs, which is updated in a recycling fashion along with residue pair representations through a novel neural attention module named Evoformer. The Evoformer contains several novel attentions, such as axial self-attention (row-wise and column-wise), triangular multiplicative update and triangular self-attention, which allow maximal information flow between the MSA and pair representations to reason about spatial and evolutionary relationships. What follows is an innovative structure module that maintains a concrete 3D backbone structure using the pair representation and the updated single sequence representation. More specifically, AlphaFold2 constructs a local frame for each residue composed of a rotation and a translation concerning the global frame, allowing the simultaneous equivariant local refinement of all structure parts. Seven torsion angles also parameterize each residue to calculate all atom coordinates, assuming that all bond angles and bond lengths are fixed. The single representation is updated by a novel invariant point attention (IPA) module, which is then used to update the local frame for each residue in an

equivariant manner. The model is trained to minimize losses of the final predicted and intermediate structures for parameter optimization with a novel frame-aligned point error.

Like other AI big models [18,20] in natural language processing, AlphaFold2 is augmented with several auxiliary losses for self-supervised training. For example, the pair representations are projected to predict pairwise binned residue distances, and similar to masked language modelling [18], the final MSA representations is used to predict masked amino acid types. Furthermore, inspired by noisy self-distillation [648], the pre-trained AlphaFold2 network is subsequently fine-tuned on a new dataset composed of predicted structures with high confidence by pre-trained AlphaFold2. The self-distillation allows the network to use the unlabelled data and effectively enhance accuracy.

**What AlphaFold2 can't do** Although AlphaFold2 has made remarkable achievements on single protein structure prediction, it is admitted that the vanilla AlphaFold2 is by no means versatile. Empirically, people find that AlphaFold2 usually struggles with multi-domain proteins and multimers. To tackle this, a series of works [1572,1573,1574,1575,1576] built upon AlphaFold2 have emerged recently. We will discuss these works in the next section. Besides, the success of AlphaFold2 relies heavily on the multiple sequence alignments (MSAs), which means that AlphaFold2 can not handle single protein sequences well. Also, it is currently unclear how well AlphaFold2 can perform on mutated proteins, de novo designed proteins, and other protein-ligand complexes.

**RoseTTAFold** RoseTTAFold [1557], an effort led by Prof. David Baker from University of Washington trying to replicate AlphaFold2, is a three-track network designed for protein structure prediction that shares similar ideas with AlphaFold2. The network produces PSP accuracies approaching DeepMind in CASP14, though it only predicts backbone coordinates and ignores sidechain placements. The main architecture of the network is highly related to that of AlphaFold2 as it drew inspiration from DeepMind's presentation before the method paper of AlphaFold2 came out. The key of RoseTTAFold is also the maximal information flow between different parts of the networks (three-track network). As a counterpart of AlphaFold2, it provides many insights to the broad bioinformatics community and has spawned lots of follow-ups [1577].

**Protein-Protein Complex Structure Prediction** Besides predicting the structure of a single protein, another very important protein is predicting the complex structure of multiple proteins, which is a fundamental problem in biology and underpins most processes in the immune system, signaling pathways, and enzyme inhibition [1578]. This is also known as the problem of *protein docking*, which aims to predict the bound 3D structure of a protein-protein complex given the structures of two proteins in the unbound state. Traditional approaches for protein docking include homology-based methods, a.k.a. template-based modeling [1579,1580,1581,1582,1583,1584,1585] and *ab initio* docking methods, a.k.a. free docking [1586,1587]. The former ones are based on template structures of homologous complexes obtained by searching databases of known structures iteratively. The latter ones typically follow three steps: 1) randomly sample a large number of orientations, 2) employ a scoring function to rank all generated candidates [1588,1589,1590,1591], and 3) refine the top complexes according to an energy model [1592]. Recent efforts have been devoted to using a hybrid of template-based and free docking and building deep learning based systems to get more accurate scoring functions [1593,1594]. The performance of these methods is usually not satisfying either due to missing good structure templates or inaccurate scoring function for ranking different orientations.

Intrigued by the recent breakthroughs of AlphaFold2 [1525] and RoseTTAFold [1557], there have been many attempts to use them as subroutines to improve protein complex structure prediction. As both AlphaFold2 and RoseTTAFold are only trained on protein monomer data sets, the challenge is how to apply them to predict the complex structure of a pair of proteins. A straightforward solution is to add a residue gap or linker segment between chains of a complex and treat it as a pseudo-monomer [1572,1573,1574,1575]. Ghani *et al.* [1595] combined this approach with their physical-based docking method ClusPro [1596]. Pei *et al.* [1597] and Humphreys *et al.* [1577] applied this method to generate a high-confidence dataset for previous unknown complex structures. Another major difficulty in generalizing protein monomer structure prediction protocols to complex structure prediction is generating and using the co-evolutionary information to guide the modeling of complexes, which are critical to predicting protein structure accurately. There are some recent attempts to construct informative MSA for multi-chain proteins based on heuristic methods [1598,1599,1600,1601]. ColabFold presented their MSA pairing solution for prokaryotes using genetic distance [1572]. Bryant *et al.* [1575] incorporated AlphaFold2 into their Fold and Dock pipeline and explored the docking process of AlphaFold2 with different extended MSAs. Nonetheless, all of these approaches still use the AlphaFold model trained on monomers and simply modify the input at the inference time, inducing a large generalization gap between training and testing.

To address this issue, DeepMind presents their solution to extend AlphaFold to multiple chains, known as AlphaFold-Multimer [1576]. Many training tricks are explicitly designed for protein complex structures. They followed Zhou *et al.*'s approach [1601] to pairing MSAs with genetic distances for prokaryotes and the similarity to the target sequence

for eukaryotes. To facilitate training on protein complex datasets, they also proposed multi-chain cropping methods and unclamped FAPE loss to put stress on interface regions, as well as a new predicted TM-score to measure model confidence. Experimental results prove its effectiveness and ability to outperform all the above methods based on inference-only modifications. This demonstrates the potential of big models in predicting the quaternary structure of complexes. However, the number of complex structures is still much smaller than that of monomer proteins. In the future, how to combine a large amount of monomer protein structures for pretraining and the limited amount of complex structures for finetuning is an important direction.

### 17.2.3 Protein Design

Protein design, also frequently referred to as the inverse problem of protein structure prediction, seeks to identify low-energy amino acid sequences that stabilize specific 3D structures or perform the desired function, e.g., binding to a receptor. Various taxonomies are used to categorize approaches to protein design. For example, based on whether structure information is involved in protein design, existing methods can be divided into **sequence-based methods** and **structure-based methods**. The former line of algorithms directly designs amino acid sequences with specific functionality based solely on sequence information (structure agnostic), while the latter line of algorithms follow the dogma of “sequence  $\rightarrow$  structure  $\rightarrow$  function” and identify the amino acid sequences adopting desired structures and performing the target function. Some other researchers divide these methods into two categories: **template-based methods** modify the sequence and structure of naturally evolved proteins to achieve specific functions. **de novo design methods** generate novel protein backbone structures and sample sequences optimal for these structures from scratch. In this section, we follow the first taxonomy and refer readers to previous surveys [1554,1602] for the second taxonomy.

**Sequence-based Methods** Due to the sequential nature of amino acid sequences, most sequence-based protein design algorithms leverage advances in the field of natural language processing (NLP), e.g., auto-regressive models and attention-based models [25,18]. To put it simply, amino acid sequences are analogous to human sentences, and typical NLP algorithms can be directly applied to them with minor modifications, e.g., language models. Usually, the vocabulary size is much smaller as there are only 20 standard amino acid types. For example, Muller et al. [1603] train long short-term memory (LSTM) networks on peptides dataset and use the resulting model for de novo sequence generation. The work has spawned a lot of follow-ups [1540,1604,1605], and differences lie in how auto-regressive generative models are defined. Apart from auto-regressive models, there have also been a lot of attempts to use VAE and GAN for de novo sequence design [1606,1607,1608], we refer readers to a previous survey [1609] for more details.

**Structure-based Methods** Typical structure-based de novo protein design algorithms begin by determining a protein fold or backbone structure according to desired properties (“structure  $\rightarrow$  function”). Backbone structures control the overall shape of proteins. Therefore, ensuring the physical realizability of backbones is crucial for the success of protein design. One common strategy for de novo backbone design is fragment assembly [1610,1611,1612], where small fragments from natural proteins with desired secondary structures are assembled into backbone structures. There have also been attempts to incorporate experts’ domain knowledge into backbone design [1613,1614,1615], and redesigning existing native backbone structures [1616,1617,1618]. Recently, machine learning-based backbone design is attracting increasing attention, thanks to the abundant structural data deposited in PDB. To name a few, Anand et al. [1619,1620] represent protein structures by pairwise distances between all backbone atoms and recover the backbone coordinates in a differentiable way. Eguchi et al. [1621] introduce a torsion- and distance-aware backbone generative model using variational autoencoder. Anishchenko et al. [1622] leverage the idea of network “hallucination”, and novelly use the trained PSP model to predict the distance map of a randomly generated input sequence, which is further optimized based on the KL-divergence between the distance map and background distribution.

Once backbone structures are given, the second step of structure-based protein design is a selection of optimal amino acid sequences that will stabilize given structures (“sequence  $\rightarrow$  structure”), a.k.a., sequence optimization. Traditional sequence optimization algorithms usually involve an energy function [1623,1624,1625] that measures the feasibility of amino acid sequences and a searching strategy for expanding the candidate sets [1626,1627,1628]. Recently, several machine learning-based methods for protein sequence design have emerged. They typically model the distribution of amino acids at each residue position conditioned on target structure [1571,1629,1630], mostly in a auto-regressive fashion. For example, Greener et al. [1631] propose a VAE-based generative model to generate sequences based on a grammar of protein structures encoded in string format. gcWGAN [1632] is a Generative Adversarial Network (GAN)-based model which generates novel sequences conditioned on the low-dimensional fold representation. Recently, transformer-based generative framework [1633,1634] are favored in literature, which uses an encoder-decoder architecture and leverages the attention mechanism [25] to infer the complex relationship between different amino acid positions.

### 17.3 Future Directions

**Effective Protein Representation Learning.** We are now witnessing exciting progress of protein representation learning by leveraging sequence modeling techniques (e.g., Transformers) from the natural language processing domain, which follows the pre-training and fine-tuning paradigm and has been shown useful in a variety of downstream applications. However, there are still a few challenges. *First*, compared to the number of labeled data in natural language processing and computer vision, the number of labeled proteins is still much limited, considering that obtaining the labeled data is very time-consuming and expensive. Therefore, how to learn meaningful protein representations in the presence of limited labeled data is a very promising direction. Besides leveraging a large amount of unlabeled protein sequences for pretraining, we can also leverage some domain knowledge to help learn better protein representations. For example, the GeneOntology<sup>13</sup> collects the functions of genes/proteins; biomedical knowledge graphs (e.g., DrugBank, STRING) encode the complex relationships between different biomedical entities, such as proteins, drugs, diseases, which would be useful to learn meaningful protein representations. Therefore, leveraging many protein sequences with the rich biomedical domain knowledge graphs (mainly organized through biomedical knowledge graphs) is a promising direction to learn effective protein representations, which allows more accurate function prediction. Besides, we can leverage techniques based on multi-task learning, transfer learning, and meta-learning to share supervision across data tasks and quickly adapt to a new task with few-labeled data by learning from a large number of related tasks.

*Second*, existing progress in computer vision and natural language understanding are largely driven by large-scale benchmarks such as ImageNet [10] and GLUE [291]. However, in the domain of protein representation learning, a large-scale and high-quality labeled protein data set is lacking, without which it is difficult to measure the progress of different machine learning techniques fairly. Moreover, a standard benchmark for protein function prediction can spur the interest of researchers in the machine learning community. Now, researchers working on protein representation learning are mainly from the bioinformatics community. It would be necessary to prepare some public data sets and open source codes to attract researchers from the machine learning community.

*Third*, though the progress on protein representation learning with amino acid sequences is very promising, utilizing the amino acid sequences is still not sufficient to predict the function of a protein. For example, some similar sequences (which could be only one or two amino acids different) could have very different structures and hence have different functions; proteins with very different amino acid sequences could have a very similar structure and hence have similar functions. Therefore, following the biology dogma “sequence  $\rightarrow$  structure  $\rightarrow$  function”, a better solution for protein representation learning or function prediction is based on their structures. Recently, thanks to the progress of structure prediction techniques such as AlphaFold and RoseTTAFold, the structures of many proteins could be accurately predicted. As a result, how to develop deep learning techniques to capture the geometric features of protein structures is an auspicious direction. Some existing techniques, such as Masif and DMasif are moving in this exciting direction.

**Protein Structure Prediction without MSA** Efficient, accurate, and low-cost structure prediction algorithms are of great practical value, which will enable many high-throughput applications in protein design. However, existing state-of-the-art methods heavily rely on the co-evolutionary information from MSAs, which suffer from two limitations: 1) a large fraction of proteins lack sequence homologs, including around 20% of all metagenomic protein sequences [1635], about 11% of eukaryotic, viral proteins [1636] and newly designed proteins; 2) the computational cost for searching MSA is pretty high due to the large size of databases used for search. For example, it only takes 5 minutes to infer the structure of one protein with RoseTTAFold on a GPU, but the computation of MSAs takes dozens of minutes, which becomes the bottleneck of the prediction process. There are some recent attempts to predict protein structures without the MSA information [1637, 1638]. As a remedy, they instead use large-scale pre-trained protein language models, which can implicitly capture co-evolutionary information but do not involve an expensive search process. Therefore, effectively combining pre-trained big language models with protein structure prediction modules for efficient protein structure prediction is an essential future direction.

**De Novo Protein Design** Most existing machine learning efforts for protein design focus on protein optimization [1527]. In other words, using machine learning methods to optimize the property of a protein candidate. How to design de novo protein remains a very challenging problem. There are some recent works that studied de novo protein design with AlphaFold2 and RoseTTAFold [1526]. In the future, further combining these systems with large-scale labeled data from high throughput bioassays will be a critical future direction.

**Interpretability** A general limitation of deep learning techniques is lacking interpretability. This has been receiving growing interests in natural language understanding and computer vision and is particularly important in protein

<sup>13</sup> <http://geneontology.org/>

modeling and in biomedical research in general. For example, for protein function prediction, it would be essential to identify the protein motifs responsible for the prediction results, allowing biologists to understand machine learning predictions better and inform the follow-up design process. Developing deep learning approaches that are able to reveal biological insights would be a huge asset for biological modeling in the future, which is also capable of bridging between computational scientists and biologists and facilitating multi-disciplinary research.

**Combining Data-Driven Methods with Physics-based Methods** We are now in an era where knowledge-based physic methods are transitioning to data-driven machine learning approaches. However, the two types of methods have both their advantages and disadvantages. An ideal solution would be to combine the best of both worlds. Traditional knowledge-based physic approaches can effectively leverage domain knowledge, offer good interpretability, but may not be accurate and slow in practice, especially for large molecule modeling; on the other end, deep learning approaches can learn from a large amount of data and hence make accurate predictions, and is also more efficient. However, for deep learning methods, the interpretability is usually not compromised, and is data hungry, which may not perform well in the presence of limited data. Indeed, in the example of protein structure prediction, deep learning techniques (e.g., AlphaFold2) have already significantly surpassed traditional physic based methods (e.g., Rosetta) thanks to the large amount of structure data collected in PDB. However, the performance of complex structure prediction with deep learning methods is still not satisfying due to the limited number of complex data, and physic-based method (e.g., ClusPro) is combined with deep learning systems (e.g., AlphaFold2) for this problem. In the future, we will see more and more deep learning approaches integrated with physic-based methods, especially in low-data applications.

**Combining Computational Methods with Experimental Methods for Protein Design.** We are witnessing technology breakthroughs in both artificial intelligence, where big models can be built for accurate predictions by training on a large amount of data, and biology, where a large amount of labeled data can be obtained through high throughput bioassays. Effectively combining computational methods with web-lab experiments would make a huge difference in future biological discovery. Specifically, web-lab experiments will be able to generate a huge amount of labeled data for training deep learning models, while deep learning models will suggest promising protein sequences for synthesizing and testing in wet-labs. A few rounds of interactions between computational methods and web-lab evaluations will likely yet be promising candidates. The key is how to effectively and efficiently combine computational methods and wet-lab experiments to reduce the number of protein sequences to be synthesized and tested. Active learning techniques offer a promising solution that balances exploiting promising candidates suggested by current models and exploring regions with large uncertainty.

To summarize,

- Big models trained on protein amino acid sequences and protein structure prediction system AlphaFold2, have already been widely used in protein modeling and are generating huge impact in biology. As the number of data is still constantly generated at an unprecedented speed (especially protein sequences), building larger models with large data sets will remain an important future direction.
- Existing protein representation learning models are still mainly based on sequences. Since protein functions are mainly determined by its 3D structure, an ideal solution for protein representation learning will be based on its 3D structures. Thanks to the recent progress by AlphaFold2 and RoseTTAFold, a huge amount of 3D structures will be available. Therefore, in the future, how to build big models based on 3D structures for protein representation learning and understanding will be an important research topic.
- As mentioned above, closing the loop between computational methods and wet-lab experiments will significantly accelerate the process of biological discovery (e.g., protein design) in the future.

## 18 Conclusion

As shown in this paper, the study of big model are introduced from four levels, which are resource, model, key technology and application. In each level, we discuss the present development and future work. Though above contents are illustrated in the view of every direction, we can still extract some general opinions of big models from them. In this section, we summarize the significance and several future research directions of big model.

### 18.1 The Significance of Big Models

**Big Models will Change the AI Research Paradigm and Improve the Efficiency of Researches.** Compared with the present domain-focused AI research situation, the emergence of big model enables the multi-field study based

on the same big model, which will effectively simplify the difficulty of artificial intelligence system construction and development. Developers can explore various possibilities and form a large developer community and commercial ecology based on the APIs of a big model similar to GPT-3 or WuDao. In this ecosystem, big models will be in the position of operating systems or basic development platforms. Meanwhile, with the help of big models, researchers have the chance to open the black box of deep network based general models, studying the mechanism and basic theory of intelligent capabilities emergence, thus further promote the technological development of AI. In addition, the big model can potentially become a new programming or human-machine cooperation paradigm. After obtaining large parameter scale from learning big data, big model allows human to use a small amount of prompt information to train or adjust their output contents. The higher the quality of human prompt information, the better the problem-solving and creative ability embodied by the big model based artificial intelligence system. This implies that human can interact with AI systems in a new cooperation paradigm similar to programming in the future, helping AI systems complete tasks better. AI will gradually solve many technical problems in the process of studying big models, which can help scientific research institutions carry out technical research with minor cost, improve the scientific research efficiency of artificial intelligence.

**The Big Model will Improve the Intelligent Level of AI Applications and Promote the Formation of A New Industrial Paradigm.** Big models can promote the AI application to a more advanced level. Presently, there are many high potential industrial application fields that big models can be applied to, such as news generation, business text analysis, legal text analysis, etc. The intervention of big model can break the traditional work pattern and inject new energy in those fields. Furthermore, big models can be beneficial to improving intelligent level of existing AI applications. For example, big model can improve the communication ability of intelligent customer service, optimize the user experience and accelerate the industrial development in related fields. Big models bring a new industrial pattern, which allows researchers to develop a variety of industrial applications on the basis of a single big model.

## 18.2 Several Directions of Future Work

### 18.2.1 Data and Knowledge

The lack of common sense and world knowledge is the pain point of big models. By training on large-scale corpus, big models can capture a series of statistical features of a language, such as language expression habit, fixed collocation and rules of grammar. However, above learned linguistic knowledge only ensures that model can output sentences in a grammatically correct and fluent form, the correction of the contents cannot be guaranteed. Therefore, adding world knowledge to the training process can guide big models output contents that are compatible with human common sense, thus further improving the intelligence level of models.

In terms of fusing data and knowledge together in model training, the mainstream approach is to express a piece of knowledge in the form of a triplet, such as (main entity, secondary entity, relation). However, the form of triplet is not applicable in all cases because the real-word knowledge and common sense are complex and even dynamic in many situations. Thus, breaking the regular triplet expression and exploring more effective data-knowledge fusion method are essential to the future development of big models.

The aim of introducing knowledge in model training and exploring effective expression method is to inject knowledge into big models as much as possible. Nevertheless, some researchers argue that it is unnecessary for big models to memorize such huge amount of knowledge. It is more important to learn the ability behind knowledge instead, including the summarization and extraction of knowledge from a piece of text. Developing these kinds of deep-level abilities in machines is also helpful for solving the problem of lack of knowledge and common sense, thus enhancing the intelligence of big models in a great extent.

### 18.2.2 Efficient Computing

Combining deep learning with self-supervised learning, big models have demonstrated amazing task versatility. However, with the trend of model scaling, expensive computational power and high consumption of training time add build-and-use barriers to big models. In order to construct and apply big models efficiently, parallel computing techniques, such as data parallel, model parallel, pipeline parallel and expert parallel, become possible solutions to accelerate the training and inference process. Presently, it remains a difficult problem to run a single node program in distributed systems, which means constructing a both programmer-friendly and high-performance parallel framework needs to be further studied.

In addition to accelerating the computing process by using parallel systems, there are some other approaches that can potentially help. By developing the compilation technique further, it is possible to design a more flexible computing

framework that can improve the training efficiency as well as maintaining training performance. Besides, the efficiency of big model training can also benefit from the proper application of mixed-precision systems and the exquisite design of domain-specific systems.

### 18.2.3 Multi-modal fusion

The AI research is trying to build human-like intelligent machine. It is not enough to train model with only one dimension data, because human can learn from the world textually, visually and acoustically. Recently, many studies have proved that visual knowledge and text knowledge enhance each other in the unified semantic space. When extending the modality of big models, some abilities and performances in specific tasks can be potentially improved. For example, the use of multimodality information can assist the model's ability of common sense learning and reasoning, and contribute to downstream tasks, such as machine translation, text generation and autonomous driving.

More effective multimodality fusion representation will be the key research direction in the future. Furthermore, the multimodality data format should not be restricted to texts, images, videos and audios. It is possible to achieve great breakthrough in the fusion of other new types of information.

### 18.2.4 Cognitive Reasoning

With continuous technological innovation, AI has increasingly entered our daily life under the support of big models. Recently, AI has relied on big data to simulate human perception, but it lacks a human thinking process. So, big models are insufficient in complex cognitive intelligence tasks such as reasoning and decision-making.

It is still far from optimal for big models to perform cognitive reasoning. Combining big models with large-scale commonsense knowledge to realize cognitive reasoning and logical expression still faces significant challenges. Developing a cognitive graph that integrates core technologies such as commonsense knowledge, logical expression, and cognitive reasoning will become the key to the big model technology breakthrough.

### 18.2.5 Theory

Currently, the mainstream architecture used for big models is transformer. Many studies find that the performance of big models can be improved constantly as model parameter scaling. Recent researches also suggest that the performance improvement brought by enlarging model parameter do exist an upper bound. However, people know little about the intelligence expression limit of the model structure like transformer. Finding the upper bound is difficult, but it is crucial for making research strategies, such as whether to continue enlarging model scale. In addition to studying the intelligence boundary of transformer-based big models, it is also necessary to explore more efficient model structure that may raise the upper bound of machine intelligence. It is challenging technically but has the high potential to achieve huge breakthrough in big model research.

In order to achieve higher levels of machine intelligence, larger models perform better and better within a certain range but with lower and lower marginal benefits. Therefore, scaling up the model is only a means to touch the upper limit of machine intelligence, and further research and exploration on the nature and laws of the model need to be conducted.

### 18.2.6 Interpretability

DNNs can be regarded as black-box models because people know little about how models output the final result according to the input information. As the big models enlarging significantly, more complex model architectures and deeper model layers make big model's interpretability harder to study. In general, the research of BM interpretability is basically to answer the question that what did BM learn and how it can be improved? Understanding that question is vital to the further development of BMs.

As an initial stage, researchers need to establish the theoretical connection between BM's different factors, such as the model's architecture, the model's data representation and the model's performance. Only when the relationship is studied clearly, there is the chance to analyze what data contribute to the model learning and what kind of knowledge can the model obtain. Furthermore, present model improvement methods are conducted in an empirical way, which means researchers adjust their work (e.g. model architecture design) directions by huge amount of experiments. Thus, establishing such kind of theoretical relation is also the basis of oriented model improvement. As the interpretability study going deeper in the future, the BM research are expected to enter an explainable manner, which means the influence of several different factors to the model performance can be quantified.

### 18.2.7 Reliability and Security

It is noted that recent research in the big models has largely emphasized the ever-larger dataset and more computing power. However, if we do not consider the security or reliability of the big models, the potential security risk would be more serious as applications of big models become deeper. The study of BM reliability and security is to ensure that models can defend various kinds of attacking approaches and then be used safely in specific tasks, especially in those human safety and confidential information related fields.

On the one hand, the output of BM itself should be more reliable. Researchers are expected to improve model performance by shifting the model training from the data-driven method to a broader coalition with a variety of knowledge. Besides, it is also valuable to study BM's ability of shared learning on confidential data and life-long learning. On the other hand, the defending system of BMs need to be further developed, including both the attack detection and the attack defending. Simulation-based technology can be applied in the risk test of BMs, providing the suggestion of potential disturbances and even their corresponding probabilities. Moreover, designing new machine learning models that can use sources to track fraudulent data is essential to the system to defend various types of adversarial attacks.

### 18.2.8 Governance

With the rapid development of big models, some serious problems appears simultaneously. For example, the privacy information leakage are found in some big model outputs. To ensure that big models are used properly and bring positive effects to the society, the governance method is worth studying.

Firstly, collaborative governance methods require multi-party participation. In addition to the government, stakeholders such as big model research organizations, big model users and other third-party institutions need to be included in the governance process. The government should play its dominant role and fully combine the advantages of all participants. For example, the government can conduct policy making under the help of research institutions' advanced technologies to solve the problem raised by big model users.

Secondly, ideal governance methods need to be effective in both global governance and modular governance. The aim of global governance is to balance the relationship between technology development and safety restrictions, thus improving big models as well as satisfying basic requirements of every stakeholder. In term of modular governance, all big-model-related domains should be taken into consideration, including data, algorithms and computing power. Governance methods need to be investigated respectively according to the real situation in different modules.

Thirdly, reliable governance methods should be dynamic, changing along with the big model development. In real-world situation, any slight progress of big models can present huge challenges to current governance system. Therefore, big model governance should maintain the idea of iterative optimization. That means, frequent updating and modification of governance methods are necessary. Additionally, rapid changes also propose higher requirements for the quickly reaction ability and flexibility of governance participants.

### 18.2.9 Evaluation

Big model evaluation systems should provide impartial comparisons between different models and give guidance for model's better development. The construction of high-quality evaluation system is also beneficial for the research of big model theory and interpretability enhancement. To improve the effectiveness and reliability of the big model evaluation system, efforts must be paid in both high-quality datasets construction and innovation of new evaluation methods. The evaluation dataset should have balance distribution and avoid bias as much as possible. As for evaluation method, it is promising to measure big models in a modular, interactive and dynamic way.

In addition to the evaluation of model performance, it is also necessary to comprehensively evaluate models' efficiency. Firstly, the computing efficiency is tightly related to the consumption of computing power and electricity energy, which is an important part considered in real application scenarios. The evaluation system targeting this aspect can help big model develop in an environmental-friendly pattern. Secondly, the models' efficiency of information representation should also be measured in a good manner. Those representation efficiency measures refer to how much information can be represented with a fixed model scale. The evaluation results are helpful in exploring better architecture for big models.

### 18.2.10 Application

Big model is a bridge connecting the technology ecology and industrial ecology of AI, driving the development of basic software and hardware and supporting the flourishing of intelligent applications. The big model will change the



industrial paradigm. Most companies can call big model API to develop intelligent applications without AI research investment. The big model is multi-task adaptive and can be applied to different tasks in multiple scenarios. Due to the fantastic performance of big models, many big model applications exist in different fields, such as text generation, AI coding, protein structure prediction, etc. In addition to the existing intelligent applications, we need to further explore the big model applications in science (mathematics, physics, life, medicine, etc.), engineering, and also interdisciplinary.

## References

1. Xu Han, Zhengyan Zhang, Ning Ding, Yuxian Gu, Xiao Liu, Yuqi Huo, Jiezhong Qiu, Liang Zhang, Wentao Han, Minlie Huang, et al. Pre-trained models: Past, present and future. *AI Open*, 2021.
2. Alex Krizhevsky, Ilya Sutskever, and Geoffrey E Hinton. Imagenet classification with deep convolutional neural networks. In *NIPS*, pages 1097–1105, 2012.
3. Kalchbrenner Nal, Grefenstette Edward, and Blunsom Phil. A convolutional neural network for modelling sentences. In *In Proceedings of ACL*, pages 655–665, 2014.
4. Ilya Sutskever, Oriol Vinyals, and Quoc V Le. Sequence to sequence learning with neural networks. In *Advances in neural information processing systems*, pages 3104–3112, 2014.
5. Donahue Jeffrey, Anne Hendricks Lisa, Guadarrama Sergio, Rohrbach Marcus, Venugopalan Subhashini, Saenko Kate, and Darrell Trevor. Long-term recurrent convolutional networks for visual recognition and description. In *In Proceedings of CVPR*, pages 2625–2634, 2015.
6. Mirza Mehdi and Osindero Simon. Conditional generative adversarial nets. *Computer Science*, pages 2672–2680, 2014.
7. Alec Radford, Luke Metz, and Soumith Chintala. Unsupervised representation learning with deep convolutional generative adversarial networks. In *ICLR*, 2016.
8. Kipf Thomas and Max Welling. Semi-supervised classification with graph convolutional networks. In *In Proceedings of ICLR*, 2016.
9. Veličković Petar, Cucurull Guillem, Casanova Arantxa, Romero Adriana, Lio Pietro, and Bengio Yoshua. Graph attention networks. In *In Proceedings of ICLR*, 2018.
10. Jia Deng, Wei Dong, Richard Socher, Li-Jia Li, Kai Li, and Li Fei-Fei. Imagenet: A large-scale hierarchical image database. In *2009 IEEE conference on computer vision and pattern recognition*, pages 248–255. Ieee, 2009.
11. Bojar Ondřej, Buck Christian, Federmann Christian, Haddow Barry, Koehn Philipp, Leveling Johannes, Monz Christof, Pecina Pavel, Post Matt, and Saint-Amand Herve. Findings of the 2014 workshop on statistical machine translation. In *In Proceedings of WMT*, pages 12–58, 2014.
12. Sinno Jialin Pan and Qiang Yang. A survey on transfer learning. *IEEE Transactions on knowledge and data engineering*, 22(10):1345–1359, 2009.
13. He Kaiming, Zhang Xiangyu, Ren Shaoqing, and Sun Jian. Deep residual learning for image recognition. In *In Proceedings of CVPR*, pages 770–778, 2016.
14. Vinyals Oriol, Toshev Alexander, Bengio Samy, and Erhan Dumitru. Show and tell: A neural image caption generator. In *In Proceedings of CVPR*, pages 3156–3164, 2015.
15. Long Jonathan, Shelhamer Evan, and Darrell Trevor. Fully convolutional networks for semantic segmentation. In *In Proceedings of CVPR*, pages 3431–3440, 2015.
16. Sermanet Pierre, Eigen David, Zhang Xiang, Mathieu Michaël, Fergus Rob, and LeCun Yann. Over-feat: Integrated recognition, localization and detection using convolutional networks. In *In Proceedings of ICLR*, 2014.
17. Mikolov Tomas, Chen Kai, Corrado Greg, and Dean Jeffrey. Efficient estimation of word representations in vector space. In *In Proceedings of ICLR Workshop*, 2013.
18. Jacob Devlin, Ming-Wei Chang, Kenton Lee, and Kristina Toutanova. Bert: Pre-training of deep bidirectional transformers for language understanding. In *Proceedings of NAACL-HLT*, pages 4171–4186, 2019.
19. Colin Raffel, Noam Shazeer, Adam Roberts, Katherine Lee, Sharan Narang, Michael Matena, Yanqi Zhou, Wei Li, and Peter J Liu. Exploring the limits of transfer learning with a unified text-to-text transformer. *arXiv preprint arXiv:1910.10683*, 2019.
20. Tom B Brown, Benjamin Mann, Nick Ryder, Melanie Subbiah, Jared Kaplan, Prafulla Dhariwal, Arvind Neelakantan, Pranav Shyam, Girish Sastry, Amanda Askell, et al. Language models are few-shot learners. *arXiv preprint arXiv:2005.14165*, 2020.
21. Rishi Bommasani, Drew A Hudson, Ehsan Adeli, Russ Altman, Simran Arora, Sydney von Arx, Michael S Bernstein, Jeannette Bohg, Antoine Bosselut, Emma Brunskill, et al. On the opportunities and risks of foundation models. *arXiv preprint arXiv:2108.07258*, 2021.
22. Ian Tenney, Dipanjan Das, and Ellie Pavlick. Bert rediscovers the classical nlp pipeline. *arXiv preprint arXiv:1905.05950*, 2019.
23. Geoffrey E Hinton, Simon Osindero, and Yee-Whye Teh. A fast learning algorithm for deep belief nets. *Neural computation*, 18(7):1527–1554, 2006.
24. Yoshua Bengio, Pascal Lamblin, Dan Popovici, and Hugo Larochelle. Greedy layer-wise training of deep networks. In *Advances in neural information processing systems*, pages 153–160, 2007.
25. Ashish Vaswani, Noam Shazeer, Niki Parmar, Jakob Uszkoreit, Llion Jones, Aidan N Gomez, Łukasz Kaiser, and Illia Polosukhin. Attention is all you need. In *NeurIPS*, 2017.

26. Alec Radford, Karthik Narasimhan, Tim Salimans, and Ilya Sutskever. Improving language understanding by generative pre-training. *OpenAI blog*, 2018.
27. Zixuan Ma, Jiaao He, Jiezhong Qiu, Huanqi Cao, Yuanwei Wang, Zhenbo Sun, Liyan Zheng, Haojie Wang, Shizhi Tang, Tianyu Zheng, Junyang Lin, Guanyu Feng, Zeqiang Huang, Jie Gao, Aohan Zeng, Jianwei Zhang, Runxin Zhong, Tianhui Shi, Sha Liu, Weimin Zheng, Jie Tang, Hongxia Yang, Xin Liu, Jidong Zhai, and Wenguang Chen. Bagualu: Targeting brain scale pretrained models with over 37 million cores. In *Proceedings of the 27th ACM SIGPLAN Symposium on Principles and Practice of Parallel Programming*, page 192–204, New York, NY, USA, 2022. Association for Computing Machinery.
28. Alexey Dosovitskiy, Lucas Beyer, Alexander Kolesnikov, Dirk Weissenborn, Xiaohua Zhai, Thomas Unterthiner, Mostafa Dehghani, Matthias Minderer, Georg Heigold, Sylvain Gelly, et al. An image is worth 16x16 words: Transformers for image recognition at scale. *arXiv preprint arXiv:2102.11929*, 2020.
29. Ze Liu, Yutong Lin, Yue Cao, Han Hu, Yixuan Wei, Zheng Zhang, Stephen Lin, and Baining Guo. Swin transformer: Hierarchical vision transformer using shifted windows. In *Proceedings of the IEEE/CVF International Conference on Computer Vision*, pages 10012–10022, 2021.
30. Robin Strudel, Ricardo Garcia, Ivan Laptev, and Cordelia Schmid. Segmenter: Transformer for semantic segmentation. *arXiv preprint arXiv:2105.05633*, 2021.
31. Alec Radford, Jong Wook Kim, Chris Hallacy, Aditya Ramesh, Gabriel Goh, Sandhini Agarwal, Girish Sastry, Amanda Askell, Pamela Mishkin, Jack Clark, et al. Learning transferable visual models from natural language supervision. In *ICML*, 2021.
32. Aditya Ramesh, Mikhail Pavlov, Gabriel Goh, Scott Gray, Chelsea Voss, Alec Radford, Mark Chen, and Ilya Sutskever. Zero-shot text-to-image generation. *arXiv preprint arXiv:2102.12092*, 2021.
33. Ming Ding, Zhuoyi Yang, Wenyi Hong, Wendi Zheng, Chang Zhou, Da Yin, Junyang Lin, Xu Zou, Zhou Shao, Hongxia Yang, et al. Cogview: Mastering text-to-image generation via transformers. *arXiv preprint arXiv:2105.13290*, 2021.
34. Yuqi Huo, Manli Zhang, Guangzhen Liu, Haoyu Lu, Yizhao Gao, Guoxing Yang, Jingyuan Wen, Heng Zhang, Baogui Xu, Weihao Zheng, et al. Wenlan: Bridging vision and language by large-scale multi-modal pre-training. *arXiv preprint arXiv:2103.06561*, 2021.
35. Liang Xu, Xuanwei Zhang, and Qianqian Dong. Cluecorpus2020: A large-scale chinese corpus for pre-training language model. *arXiv preprint arXiv:2003.01355*, 2020.
36. Sha Yuan, Hanyu Zhao, Zhengxiao Du, Ming Ding, Xiao Liu, Yukuo Cen, Xu Zou, Zhilin Yang, and Jie Tang. Wudao-corpora: A super large-scale chinese corpora for pre-training language models. *AI Open*, 2021.
37. Wei Zeng, Xiaozhe Ren, Teng Su, Hui Wang, Yi Liao, Zhiwei Wang, Xin Jiang, ZhenZhang Yang, Kaisheng Wang, Xiaoda Zhang, et al. Pangu- $\alpha$ : Large-scale autoregressive pretrained chinese language models with auto-parallel computation. *arXiv preprint arXiv:2104.12369*, 2021.
38. Miltiadis Allamanis. The adverse effects of code duplication in machine learning models of code. In *Proceedings of the 2019 ACM SIGPLAN International Symposium on New Ideas, New Paradigms, and Reflections on Programming and Software*, pages 143–153, 2019.
39. Katherine Lee, Daphne Ippolito, Andrew Nystrom, Chiyuan Zhang, Douglas Eck, Chris Callison-Burch, and Nicholas Carlini. Deduplicating training data makes language models better. *arXiv preprint arXiv:2107.06499*, 2021.
40. Jack Bandy and Nicholas Vincent. Addressing "documentation debt" in machine learning research: A retrospective datasheet for bookcorpus. *arXiv preprint arXiv:2105.05241*, 2021.
41. Yukun Zhu, Ryan Kiros, Rich Zemel, Ruslan Salakhutdinov, Raquel Urtasun, Antonio Torralba, and Sanja Fidler. Aligning books and movies: Towards story-like visual explanations by watching movies and reading books. In *Proceedings of the IEEE international conference on computer vision*, pages 19–27, 2015.
42. Nicholas Carlini, Florian Tramèr, Eric Wallace, Matthew Jagielski, Ariel Herbert-Voss, Katherine Lee, Adam Roberts, Tom Brown, Dawn Song, Ulfar Erlingsson, et al. Extracting training data from large language models. In *30th USENIX Security Symposium (USENIX Security 21)*, pages 2633–2650, 2021.
43. Devansh Arpit, Stanisław Jastrzębski, Nicolas Ballas, David Krueger, Emmanuel Bengio, Maxinder S Kanwal, Tegan Maharaj, Asja Fischer, Aaron Courville, Yoshua Bengio, et al. A closer look at memorization in deep networks. In *International Conference on Machine Learning*, pages 233–242. PMLR, 2017.
44. Ryan Webster, Julien Rabin, Loic Simon, and Frédéric Jurie. Detecting overfitting of deep generative networks via latent recovery. In *Proceedings of the IEEE/CVF Conference on Computer Vision and Pattern Recognition*, pages 11273–11282, 2019.
45. Vitaly Feldman and Chiyuan Zhang. What neural networks memorize and why: Discovering the long tail via influence estimation. *arXiv preprint arXiv:2008.03703*, 2020.
46. Cory Stephenson, Suchismita Padhy, Abhinav Ganesh, Yue Hui, Hanlin Tang, and SueYeon Chung. On the geometry of generalization and memorization in deep neural networks. *arXiv preprint arXiv:2105.14602*, 2021.
47. Piotr Teterwak, Chiyuan Zhang, Dilip Krishnan, and Michael C Mozer. Understanding invariance via feedforward inversion of discriminatively trained classifiers. In *International Conference on Machine Learning*, pages 10225–10235. PMLR, 2021.
48. Alec Radford, Jeffrey Wu, Rewon Child, David Luan, Dario Amodei, Ilya Sutskever, et al. Language models are unsupervised multitask learners. *OpenAI blog*, 1(8):9, 2019.
49. Andrei Z Broder. On the resemblance and containment of documents. In *Proceedings. Compression and Complexity of SEQUENCES 1997 (Cat. No. 97TB100171)*, pages 21–29. IEEE, 1997.

50. Udi Manber and Gene Myers. Suffix arrays: a new method for on-line string searches. *siam Journal on Computing*, 22(5):935–948, 1993.
51. Tomáš Mikolov, Wen-tau Yih, and Geoffrey Zweig. Linguistic regularities in continuous space word representations. In *Proceedings of the 2013 conference of the north american chapter of the association for computational linguistics: Human language technologies*, pages 746–751, 2013.
52. Tomas Mikolov, Ilya Sutskever, Kai Chen, Greg S Corrado, and Jeff Dean. Distributed representations of words and phrases and their compositionality. In *NIPS*, 2013.
53. Tolga Bolukbasi, Kai-Wei Chang, James Y Zou, Venkatesh Saligrama, and Adam T Kalai. Man is to computer programmer as woman is to homemaker? debiasing word embeddings. *Advances in neural information processing systems*, 29:4349–4357, 2016.
54. Latanya Sweeney. Discrimination in online ad delivery. *Communications of the ACM*, 56(5):44–54, 2013.
55. Amit Datta, Michael Carl Tschantz, and Anupam Datta. Automated experiments on ad privacy settings. *Proceedings on Privacy Enhancing Technologies*, 2015(1):92–112, 2015.
56. Samuel Gehman, Suchin Gururangan, Maarten Sap, Yejin Choi, and Noah A Smith. Realtotoxicityprompts: Evaluating neural toxic degeneration in language models. In *Findings of the Association for Computational Linguistics: EMNLP 2020*, pages 3356–3369, 2020.
57. Nathaniel Swinger, Maria De-Arteaga, Neil Thomas Heffernan IV, Mark DM Leiserson, and Adam Tauman Kalai. What are the biases in my word embedding? In *Proceedings of the 2019 AAAI/ACM Conference on AI, Ethics, and Society*, pages 305–311, 2019.
58. Timo Spinde, Manuel Plank, Jan-David Krieger, Terry Ruas, Bela Gipp, and Akiko Aizawa. Neural Media Bias Detection Using Distant Supervision With BABE - Bias Annotations By Experts. In *Findings of the Association for Computational Linguistics: EMNLP 2021*, pages 1166–1177, Punta Cana, Dominican Republic, November 2021. Association for Computational Linguistics.
59. Yuta Nakamura, Shouhei Hanaoka, Yukihiro Nomura, Naoto Hayashi, Osamu Abe, Shuntaro Yada, Shoko Wakamiya, and Eiji Aramaki. Kart: Privacy leakage framework of language models pre-trained with clinical records. *arXiv preprint arXiv:2101.00036*, 2020.
60. Omer Levy and Yoav Goldberg. Linguistic regularities in sparse and explicit word representations. In *Proceedings of the eighteenth conference on computational natural language learning*, pages 171–180, 2014.
61. Jeffrey Pennington, Richard Socher, and Christopher D Manning. Glove: Global vectors for word representation. In *Proceedings of the 2014 conference on empirical methods in natural language processing (EMNLP)*, pages 1532–1543, 2014.
62. Dani Yogatama, Manaal Faruqui, Chris Dyer, and Noah Smith. Learning word representations with hierarchical sparse coding. In *International Conference on Machine Learning*, pages 87–96. PMLR, 2015.
63. Alicia Parrish, Angelica Chen, Nikita Nangia, Vishakh Padmakumar, Jason Phang, Jana Thompson, Phu Mon Htut, and Samuel R Bowman. Bbq: A hand-built bias benchmark for question answering. *arXiv preprint arXiv:2110.08193*, 2021.
64. Alex Tamkin, Miles Brundage, Jack Clark, and Deep Ganguli. Understanding the capabilities, limitations, and societal impact of large language models. *arXiv preprint arXiv:2102.02503*, 2021.
65. Nitish Shirish Keskar, Bryan McCann, Lav R Varshney, Caiming Xiong, and Richard Socher. Ctrl: A conditional transformer language model for controllable generation. *arXiv preprint arXiv:1909.05858*, 2019.
66. Robert L Logan IV, Nelson F Liu, Matthew E Peters, Matt Gardner, and Sameer Singh. Barack’s wife hillary: Using knowledge-graphs for fact-aware language modeling. *arXiv preprint arXiv:1906.07241*, 2019.
67. Nisan Stiennon, Long Ouyang, Jeff Wu, Daniel M Ziegler, Ryan Lowe, Chelsea Voss, Alec Radford, Dario Amodei, and Paul Christiano. Learning to summarize from human feedback. *arXiv preprint arXiv:2009.01325*, 2020.
68. Timnit Gebru, Jamie Morgenstern, Briana Vecchione, Jennifer Wortman Vaughan, Hanna Wallach, Hal Daumé III, and Kate Crawford. Datasheets for datasets. *arXiv preprint arXiv:1803.09010*, 2018.
69. Oshin Agarwal, Heming Ge, Siamak Shakeri, and Rami Al-Rfou. Knowledge graph based synthetic corpus generation for knowledge-enhanced language model pre-training. *arXiv preprint arXiv:2010.12688*, 2020.
70. Peter West, Chandra Bhagavatula, Jack Hessel, Jena D Hwang, Liwei Jiang, Ronan Le Bras, Ximing Lu, Sean Welleck, and Yejin Choi. Symbolic knowledge distillation: from general language models to commonsense models. *arXiv preprint arXiv:2110.07178*, 2021.
71. Hanyu Zhao, Sha Yuan, Jiahong Leng, Xiang Pan, and Guoqiang Wang. Calculating question similarity is enough: A new method for kbqa tasks. *arXiv preprint arXiv:2111.07658*, 2021.
72. Dumitru Erhan, Pierre-Antoine Manzagol, Yoshua Bengio, Samy Bengio, and Pascal Vincent. The difficulty of training deep architectures and the effect of unsupervised pre-training. In *Artificial Intelligence and Statistics*, pages 153–160. PMLR, 2009.
73. Dumitru Erhan, Aaron Courville, Yoshua Bengio, and Pascal Vincent. Why does unsupervised pre-training help deep learning? In *Proceedings of the thirteenth international conference on artificial intelligence and statistics*, pages 201–208. JMLR Workshop and Conference Proceedings, 2010.
74. Samuel Humeau, Kurt Shuster, Marie-Anne Lachaux, and Jason Weston. Poly-encoders: Architectures and pre-training strategies for fast and accurate multi-sentence scoring. In *International Conference on Learning Representations*, 2019.
75. Nandan Thakur, Nils Reimers, Johannes Daxenberger, and Iryna Gurevych. Augmented sbert: Data augmentation method for improving bi-encoders for pairwise sentence scoring tasks. In *Proceedings of the 2021 Conference of the North American Chapter of the Association for Computational Linguistics: Human Language Technologies*, pages 296–310, 2021.

76. Yoav Levine, Noam Wies, Daniel Jannai, Dan Navon, Yedid Hoshen, and Amnon Shashua. The inductive bias of in-context learning: Rethinking pretraining example design. *arXiv preprint arXiv:2110.04541*, 2021.
77. Suchin Gururangan, Ana Marasović, Swabha Swayamdipta, Kyle Lo, Iz Beltagy, Doug Downey, and Noah A Smith. Don't stop pretraining: adapt language models to domains and tasks. *arXiv preprint arXiv:2004.10964*, 2020.
78. Sarvesh Soni and Kirk Roberts. Evaluation of dataset selection for pre-training and fine-tuning transformer language models for clinical question answering. In *Proceedings of The 12th Language Resources and Evaluation Conference*, pages 5532–5538, 2020.
79. Xingcheng Yao, Yanan Zheng, Xiacong Yang, and Zhilin Yang. Nlp from scratch without large-scale pretraining: A simple and efficient framework. *arXiv preprint arXiv:2111.04130*, 2021.
80. Alex Warstadt and Samuel R Bowman. Can neural networks acquire a structural bias from raw linguistic data? *arXiv preprint arXiv:2007.06761*, 2020.
81. Yonatan Bisk, Ari Holtzman, Jesse Thomason, Jacob Andreas, Yoshua Bengio, Joyce Chai, Mirella Lapata, Angeliki Lazaridou, Jonathan May, Aleksandr Nisnevich, et al. Experience grounds language. *arXiv preprint arXiv:2004.10151*, 2020.
82. Piyush Sharma, Nan Ding, Sebastian Goodman, and Radu Soricut. Conceptual captions: A cleaned, hypernymed, image alt-text dataset for automatic image captioning. In *Proceedings of the 56th Annual Meeting of the Association for Computational Linguistics (Volume 1: Long Papers)*, pages 2556–2565, 2018.
83. Di Qi, Lin Su, Jia Song, Edward Cui, Taroon Bharti, and Arun Sacheti. Imagebert: Cross-modal pre-training with large-scale weak-supervised image-text data. *arXiv preprint arXiv:2001.07966*, 2020.
84. Douglas B Lenat. Cyc: A large-scale investment in knowledge infrastructure. *Communications of the ACM*, 38(11):33–38, 1995.
85. George A Miller. *WordNet: An electronic lexical database*. MIT press, 1998.
86. Zhendong Dong and Qiang Dong. *Hownet and the computation of meaning (with Cd-rom)*. World Scientific, 2006.
87. Sören Auer, Christian Bizer, Georgi Kobilarov, Jens Lehmann, Richard Cyganiak, and Zachary Ives. Dbpedia: A nucleus for a web of open data. In *The semantic web*, pages 722–735. Springer, 2007.
88. Kurt Bollacker, Colin Evans, Praveen Paritosh, Tim Sturge, and Jamie Taylor. Freebase: a collaboratively created graph database for structuring human knowledge. In *Proceedings of the 2008 ACM SIGMOD international conference on Management of data*, pages 1247–1250, 2008.
89. Fabian M Suchanek, Gjergji Kasneci, and Gerhard Weikum. Yago: a core of semantic knowledge. In *Proceedings of the 16th international conference on World Wide Web*, pages 697–706, 2007.
90. Andrew Carlson, Justin Betteridge, Bryan Kisiel, Burr Settles, Estevam R Hruschka, and Tom M Mitchell. Toward an architecture for never-ending language learning. In *Twenty-Fourth AAAI conference on artificial intelligence*, 2010.
91. Oren Etzioni, Michael Cafarella, Doug Downey, Stanley Kok, Ana-Maria Popescu, Tal Shaked, Stephen Soderland, Daniel S Weld, and Alexander Yates. Web-scale information extraction in knowitall: (preliminary results). In *Proceedings of the 13th international conference on World Wide Web*, pages 100–110, 2004.
92. Fabio Petroni, Tim Rocktäschel, Sebastian Riedel, Patrick Lewis, Anton Bakhtin, Yuxiang Wu, and Alexander Miller. Language models as knowledge bases? In *Proceedings of EMNLP-IJCNLP*, pages 2463–2473, 2019.
93. Xin Dong, Evgeniy Gabrilovich, Jeremy Heitz, Wilko Horn, Ni Lao, Kevin Murphy, Thomas Strohmman, Shaohua Sun, and Wei Zhang. Knowledge vault: A web-scale approach to probabilistic knowledge fusion. In *Proceedings of the 20th ACM SIGKDD international conference on Knowledge discovery and data mining*, pages 601–610, 2014.
94. Antoine Bordes, Jason Weston, Ronan Collobert, and Yoshua Bengio. Learning structured embeddings of knowledge bases. In *AAAI*, 2011.
95. Xin Lv, Xu Han, Lei Hou, Juan-Zi Li, Zhiyuan Liu, Wei Zhang, Yichi Zhang, Hao Kong, and Suhui Wu. Dynamic anticipation and completion for multi-hop reasoning over sparse knowledge graph. In *EMNLP*, 2020.
96. Antoine Bordes, Nicolas Usumier, Alberto Garcia-Duran, Jason Weston, and Oksana Yakhnenko. Translating embeddings for modeling multi-relational data. *Advances in neural information processing systems*, 26, 2013.
97. Zhiqing Sun, Zhihong Deng, Jian-Yun Nie, and Jian Tang. Rotate: Knowledge graph embedding by relational rotation in complex space. *ArXiv*, abs/1902.10197, 2019.
98. Zhen Wang, Jianwen Zhang, Jianlin Feng, and Zheng Chen. Knowledge graph embedding by translating on hyperplanes. In *AAAI*, 2014.
99. Yankai Lin, Zhiyuan Liu, Maosong Sun, Yang Liu, and Xuan Zhu. Learning entity and relation embeddings for knowledge graph completion. In *AAAI*, 2015.
100. Guoliang Ji, Shizhu He, Liheng Xu, Kang Liu, and Jun Zhao. Knowledge graph embedding via dynamic mapping matrix. In *ACL*, 2015.
101. Guoliang Ji, Kang Liu, Shizhu He, and Jun Zhao. Knowledge graph completion with adaptive sparse transfer matrix. In *AAAI*, 2016.
102. Yankai Lin, Zhiyuan Liu, Huanbo Luan, Maosong Sun, Siwei Rao, and Song Liu. Modeling relation paths for representation learning of knowledge bases. In *EMNLP*, 2015.
103. Han Xiao, Minlie Huang, and Xiaoyan Zhu. From one point to a manifold: knowledge graph embedding for precise link prediction. In *AAAI*, 2016.
104. Maximilian Nickel, Volker Tresp, and Hans-Peter Kriegel. A three-way model for collective learning on multi-relational data. In *ICML*, 2011.

105. Bishan Yang, Wen-tau Yih, Xiaodong He, Jianfeng Gao, and Li Deng. Embedding entities and relations for learning and inference in knowledge bases. *arXiv preprint arXiv:1412.6575*, 2014.
106. Maximilian Nickel, Lorenzo Rosasco, Tomaso A Poggio, et al. Holographic embeddings of knowledge graphs. In *AAAI*, 2016.
107. Théo Trouillon, Johannes Welbl, Sebastian Riedel, Éric Gaussier, and Guillaume Bouchard. Complex embeddings for simple link prediction. In *ICML*, 2016.
108. Zhigang Wang and Juan-Zi Li. Text-enhanced representation learning for knowledge graph. In *IJCAI*, 2016.
109. Ruobing Xie, Zhiyuan Liu, Jia Jia, Huanbo Luan, and Maosong Sun. Representation learning of knowledge graphs with entity descriptions. In *AAAI*, 2016.
110. Quan Wang, Bin Wang, and Li Guo. Knowledge base completion using embeddings and rules. In *IJCAI*, 2015.
111. Shu Guo, Quan Wang, Lihong Wang, Bin Wang, and Li Guo. Jointly embedding knowledge graphs and logical rules. In *EMNLP*, 2016.
112. Tim Rocktäschel, Sameer Singh, and Sebastian Riedel. Injecting logical background knowledge into embeddings for relation extraction. In *NAACL*, 2015.
113. Rajarshi Das, Shehzaad Dhuliawala, Manzil Zaheer, Luke Vilnis, Ishan Durugkar, Akshay Krishnamurthy, Alex Smola, and Andrew McCallum. Go for a walk and arrive at the answer: Reasoning over paths in knowledge bases using reinforcement learning. In *ICLR*, 2018.
114. Yelong Shen, Jianshu Chen, Po-Sen Huang, Yuqing Guo, and Jianfeng Gao. M-walk: Learning to walk over graphs using monte carlo tree search. In *NIPS*, 2018.
115. Xi Victoria Lin, Richard Socher, and Caiming Xiong. Multi-hop knowledge graph reasoning with reward shaping. In *EMNLP*, 2018.
116. Xin Lv, Yuxian Gu, Xu Han, Lei Hou, Juanzi Li, and Zhiyuan Liu. Adapting meta knowledge graph information for multi-hop reasoning over few-shot relations. In *EMNLP*, 2019.
117. Cong Fu, Tong Chen, Meng Qu, Woojeong Jin, and Xiang Ren. Collaborative policy learning for open knowledge graph reasoning. In *EMNLP*, 2019.
118. Tim Rocktäschel and Sebastian Riedel. End-to-end differentiable proving. In *NIPS*, 2017.
119. Fan Yang, Zhilin Yang, and William W Cohen. Differentiable learning of logical rules for knowledge base reasoning. In *NIPS*, 2017.
120. Glen Jeh and Jennifer Widom. Simrank: a measure of structural-context similarity. In *Proceedings of the Eighth ACM SIGKDD International Conference on Knowledge Discovery and Data Mining, July 23-26, 2002, Edmonton, Alberta, Canada, 2002*.
121. Sergey Melnik, Hector Garcia-Molina, and Erhard Rahm. Similarity flooding: A versatile graph matching algorithm and its application to schema matching. In *Proceedings of the 18th International Conference on Data Engineering, San Jose, CA, USA, February 26 - March 1, 2002, 2002*.
122. Juanzi Li, Jie Tang, Yi Li, and Qiong Luo. Rimom: A dynamic multistrategy ontology alignment framework. *IEEE Trans. Knowl. Data Eng.*, 2009.
123. Wei Shen, Jianyong Wang, Ping Luo, and Min Wang. Linking named entities in tweets with knowledge base via user interest modeling. In *The 19th ACM SIGKDD International Conference on Knowledge Discovery and Data Mining, KDD 2013, Chicago, IL, USA, August 11-14, 2013, 2013*.
124. Cheng Fu, Xianpei Han, Le Sun, Bo Chen, Wei Zhang, Suhui Wu, and Hao Kong. End-to-end multi-perspective matching for entity resolution. In *Proceedings of the Twenty-Eighth International Joint Conference on Artificial Intelligence, IJCAI 2019, Macao, China, August 10-16, 2019, 2019*.
125. Cheng Fu, Xianpei Han, Jiaming He, and Le Sun. Hierarchical matching network for heterogeneous entity resolution. In *Proceedings of the Twenty-Ninth International Joint Conference on Artificial Intelligence, IJCAI 2020, 2020*.
126. Yuliang Li, Jinfeng Li, Yoshihiko Suhara, AnHai Doan, and Wang-Chiew Tan. Deep entity matching with pre-trained language models. *Proc. VLDB Endow.*, 2020.
127. Zijun Yao, Chengjiang Li, Tiansi Dong, Xin Lv, Jifan Yu, Lei Hou, Juanzi Li, Yichi Zhang, and Zelin Dai. Interpretable and low-resource entity matching via decoupling feature learning from decision making. In *Proceedings of the 59th Annual Meeting of the Association for Computational Linguistics and the 11th International Joint Conference on Natural Language Processing*, pages 2770–2781. Association for Computational Linguistics, 2021.
128. Pradap Konda, Sanjib Das, Paul Suganthan G. C., AnHai Doan, Adel Ardalan, Jeffrey R. Ballard, Han Li, Fatemah Panahi, Haojun Zhang, Jeffrey F. Naughton, Shishir Prasad, Ganesh Krishnan, Rohit Deep, and Vijay Raghavendra. Magellan: Toward building entity matching management systems over data science stacks. *Proc. VLDB Endow.*, 2016.
129. Sidharth Mudgal, Han Li, Theodoros Rekatsinas, AnHai Doan, Youngchoon Park, Ganesh Krishnan, Rohit Deep, Esteban Arcaute, and Vijay Raghavendra. Deep learning for entity matching: A design space exploration. In *Proceedings of the 2018 International Conference on Management of Data, SIGMOD Conference 2018, Houston, TX, USA, June 10-15, 2018, 2018*.
130. Amir Globerson, Nevena Lazic, Soumen Chakrabarti, Amarnag Subramanya, Michael Ringgaard, and Fernando Pereira. Collective entity resolution with multi-focal attention. In *Proceedings of the 54th Annual Meeting of the Association for Computational Linguistics (Volume 1: Long Papers)*, pages 621–631, 2016.
131. Yixin Cao, Lei Hou, Juanzi Li, and Zhiyuan Liu. Neural collective entity linking. In *Proceedings of the 27th International Conference on Computational Linguistics*, pages 675–686, 2018.

132. Ledell Wu, Fabio Petroni, Martin Josifoski, Sebastian Riedel, and Luke Zettlemoyer. Scalable zero-shot entity linking with dense entity retrieval. In *Proceedings of the 2020 Conference on Empirical Methods in Natural Language Processing (EMNLP)*, pages 6397–6407, 2020.
133. Nicola De Cao, Ledell Wu, Kashyap Papat, Mikel Artetxe, Naman Goyal, Mikhail Plekhanov, Luke Zettlemoyer, Nicola Cancedda, Sebastian Riedel, and Fabio Petroni. Multilingual autoregressive entity linking. 2021.
134. Henry M Wellman and Susan A Gelman. Knowledge acquisition in foundational domains. 1998.
135. James Fan, Aditya Kalyanpur, David C Gondek, and David A Ferrucci. Automatic knowledge extraction from documents. *IBM Journal of Research and Development*, 56(3.4):5–1, 2012.
136. Chen Jia, Yuefeng Shi, Qinrong Yang, and Yue Zhang. Entity enhanced bert pre-training for chinese ner. In *Proceedings of the 2020 Conference on Empirical Methods in Natural Language Processing (EMNLP)*, pages 6384–6396, 2020.
137. Byunggil Joe, Sung Ju Hwang, and Insik Shin. Learning to disentangle robust and vulnerable features for adversarial detection. *arXiv preprint arXiv:1909.04311*, 2019.
138. Ruize Wang, Duyu Tang, Nan Duan, Zhongyu Wei, Xuanjing Huang, Guihong Cao, Daxin Jiang, Ming Zhou, et al. K-adapter: Infusing knowledge into pre-trained models with adapters. *arXiv preprint arXiv:2002.01808*, 2020.
139. Xiaoya Li, Fan Yin, Zijun Sun, Xiayu Li, Arianna Yuan, Duo Chai, Mingxin Zhou, and Jiwei Li. Entity-relation extraction as multi-turn question answering. In *Proceedings of the 57th Annual Meeting of the Association for Computational Linguistics*, pages 1340–1350, Florence, Italy, July 2019. Association for Computational Linguistics.
140. Christoph Alt, Marc Hübner, and Leonhard Hennig. Fine-tuning pre-trained transformer language models to distantly supervised relation extraction. In *Proceedings of the 57th Annual Meeting of the Association for Computational Linguistics*, pages 1388–1398, Florence, Italy, July 2019. Association for Computational Linguistics.
141. Zhijiang Guo, Yan Zhang, and Wei Lu. Attention guided graph convolutional networks for relation extraction. In *Proceedings of the 57th Annual Meeting of the Association for Computational Linguistics*, pages 241–251, Florence, Italy, July 2019. Association for Computational Linguistics.
142. Tapas Nayak and Hwee Tou Ng. Effective modeling of encoder-decoder architecture for joint entity and relation extraction. In *Proceedings of the AAAI Conference on Artificial Intelligence*, volume 34, pages 8528–8535, 2020.
143. Zexuan Zhong, Dan Friedman, and Danqi Chen. Factual probing is [mask]: Learning vs. learning to recall.
144. Xiang Lisa Li and Percy Liang. Prefix-tuning: Optimizing continuous prompts for generation. *arXiv preprint arXiv:2101.00190*, 2021.
145. Timo Schick and Hinrich Schütze. It’s not just size that matters: Small language models are also few-shot learners. *arXiv preprint arXiv:2009.07118*, 2020.
146. Xu Han, Weilin Zhao, Ning Ding, Zhiyuan Liu, and Maosong Sun. Ptr: Prompt tuning with rules for text classification. *arXiv preprint arXiv:2105.11259*, 2021.
147. James Henderson, Sebastian Ruder, et al. Compacter: Efficient low-rank hypercomplex adapter layers. In *Thirty-Fifth Conference on Neural Information Processing Systems*, 2021.
148. Xiaoya Li, Jingrong Feng, Yuxian Meng, Qinghong Han, Fei Wu, and Jiwei Li. A unified mrc framework for named entity recognition. In *Proceedings of the 58th Annual Meeting of the Association for Computational Linguistics*, pages 5849–5859, 2020.
149. Guy Kushilevitz, Shaul Markovitch, and Yoav Goldberg. A two-stage masked LM method for term set expansion. In *Proceedings of the 58th Annual Meeting of the Association for Computational Linguistics*, pages 6829–6835, Online, July 2020. Association for Computational Linguistics.
150. Jiaming Shen, Wenda Qiu, Jingbo Shang, Michelle Vanni, Xiang Ren, and Jiawei Han. Synsetexpan: An iterative framework for joint entity set expansion and synonym discovery. In *Proceedings of the 2020 Conference on Empirical Methods in Natural Language Processing (EMNLP)*, pages 8292–8307, 2020.
151. Yunyi Zhang, Jiaming Shen, Jingbo Shang, and Jiawei Han. Empower entity set expansion via language model probing. In *Proceedings of the 58th Annual Meeting of the Association for Computational Linguistics*, pages 8151–8160, 2020.
152. Seonghyeon Ye, Jiseon Kim, and Alice Oh. Efficient contrastive learning via novel data augmentation and curriculum learning. In *Proceedings of the 2021 Conference on Empirical Methods in Natural Language Processing*, pages 1832–1838, Online and Punta Cana, Dominican Republic, November 2021. Association for Computational Linguistics.
153. Shuguang Chen, Gustavo Aguilar, Leonardo Neves, and Thamar Solorio. Data augmentation for cross-domain named entity recognition. In *Proceedings of the 2021 Conference on Empirical Methods in Natural Language Processing*, pages 5346–5356, Online and Punta Cana, Dominican Republic, November 2021. Association for Computational Linguistics.
154. Jian Liu, Yufeng Chen, and Jinan Xu. Machine reading comprehension as data augmentation: A case study on implicit event argument extraction. In *Proceedings of the 2021 Conference on Empirical Methods in Natural Language Processing*, pages 2716–2725, Online and Punta Cana, Dominican Republic, November 2021. Association for Computational Linguistics.
155. Kun Zhou, Wayne Xin Zhao, Sirui Wang, Fuzheng Zhang, Wei Wu, and Ji-Rong Wen. Virtual data augmentation: A robust and general framework for fine-tuning pre-trained models. *arXiv preprint arXiv:2109.05793*, 2021.
156. Varun Kumar, Ashutosh Choudhary, and Eunah Cho. Data augmentation using pre-trained transformer models. *arXiv preprint arXiv:2003.02245*, 2020.
157. Yu Meng, Yunyi Zhang, Jiaxin Huang, Xuan Wang, Yu Zhang, Heng Ji, and Jiawei Han. Distantly-supervised named entity recognition with noise-robust learning and language model augmented self-training. *arXiv preprint arXiv:2109.05003*, 2021.

158. Joshua Meier, Roshan Rao, Robert Verkuil, Jason Liu, Tom Sercu, and Alexander Rives. Language models enable zero-shot prediction of the effects of mutations on protein function. *bioRxiv*, 2021.
159. Benjamin Heinzerling and Kentaro Inui. Language models as knowledge bases: On entity representations, storage capacity, and paraphrased queries. *arXiv preprint arXiv:2008.09036*, 2020.
160. Chenguang Wang, Xiao Liu, and Dawn Song. Language models are open knowledge graphs. *arXiv preprint arXiv:2010.11967*, 2020.
161. Haitian Sun, Pat Verga, Bhuwan Dhingra, Ruslan Salakhutdinov, and William W Cohen. Reasoning over virtual knowledge bases with open predicate relations. *arXiv preprint arXiv:2102.07043*, 2021.
162. Zhengyan Zhang, Xu Han, Zhiyuan Liu, Xin Jiang, Maosong Sun, and Qun Liu. Ernie: Enhanced language representation with informative entities. *arXiv preprint arXiv:1905.07129*, 2019.
163. Xiaozhi Wang, Tianyu Gao, Zhaocheng Zhu, Zhengyan Zhang, Zhiyuan Liu, Juanzi Li, and Jian Tang. Kepler: A unified model for knowledge embedding and pre-trained language representation. *Transactions of the Association for Computational Linguistics*, 9:176–194, 2021.
164. Wenhan Xiong, Jingfei Du, William Yang Wang, and Veselin Stoyanov. Pretrained encyclopedia: Weakly supervised knowledge-pretrained language model. In *Proceedings of ICLR*, 2019.
165. Yusheng Su, Xu Han, Zhengyan Zhang, Yankai Lin, Peng Li, Zhiyuan Liu, Jie Zhou, and Maosong Sun. Cokbert: Contextual knowledge selection and embedding towards enhanced pre-trained language models. *AI Open*, 2:127–134, 2021.
166. Wenhui Chen, Yu Su, Xifeng Yan, and William Yang Wang. Kgpt: Knowledge-grounded pre-training for data-to-text generation. *arXiv preprint arXiv:2010.02307*, 2020.
167. Ikuya Yamada, Akari Asai, Hiroyuki Shindo, Hideaki Takeda, and Yuji Matsumoto. Luke: deep contextualized entity representations with entity-aware self-attention. *arXiv preprint arXiv:2010.01057*, 2020.
168. Antoine Bosselut, Hannah Rashkin, Maarten Sap, Chaitanya Malaviya, Asli Celikyilmaz, and Yejin Choi. COMET: commonsense transformers for automatic knowledge graph construction. In *Proceedings of the 57th Conference of the Association for Computational Linguistics, ACL 2019, Florence, Italy, July 28- August 2, 2019, Volume 1: Long Papers*, pages 4762–4779, 2019.
169. Haozhe Ji, Pei Ke, Shaohan Huang, Furu Wei, Xiaoyan Zhu, and Minlie Huang. Language generation with multi-hop reasoning on commonsense knowledge graph. *arXiv preprint arXiv:2009.11692*, 2020.
170. Ye Liu, Yao Wan, Lifang He, Hao Peng, and Philip S Yu. Kg-bart: Knowledge graph-augmented bart for generative commonsense reasoning. *arXiv preprint arXiv:2009.12677*, 2020.
171. Jian Guan, Fei Huang, Zhihao Zhao, Xiaoyan Zhu, and Minlie Huang. A knowledge-enhanced pretraining model for commonsense story generation. *Transactions of the Association for Computational Linguistics*, 8:93–108, 2020.
172. Bin He, Di Zhou, Jinghui Xiao, Qun Liu, Nicholas Jing Yuan, Tong Xu, et al. Integrating graph contextualized knowledge into pre-trained language models. *arXiv preprint arXiv:1912.00147*, 2019.
173. Xiao Liu, Da Yin, Xingjian Zhang, Kai Su, Kan Wu, Hongxia Yang, and Jie Tang. Oag-bert: Pre-train heterogeneous entity-augmented academic language models. *arXiv preprint arXiv:2103.02410*, 2021.
174. Robyn Speer, Joshua Chin, and Catherine Havasi. Conceptnet 5.5: An open multilingual graph of general knowledge. In *Proceedings of the Thirty-First AAAI Conference on Artificial Intelligence, February 4-9, 2017, San Francisco, California, USA*, pages 4444–4451, 2017.
175. Maarten Sap, Ronan Le Bras, Emily Allaway, Chandra Bhagavatula, Nicholas Lourie, Hannah Rashkin, Brendan Roof, Noah A. Smith, and Yejin Choi. ATOMIC: an atlas of machine commonsense for if-then reasoning. In *The Thirty-Third Conference on Artificial Intelligence, Honolulu, Hawaii, USA, January 27 - February 1, 2019*, pages 3027–3035. AAAI Press, 2019.
176. Olivier Bodenreider. The unified medical language system (umls): integrating biomedical terminology. *Nucleic acids research*, 32(suppl\_1):D267–D270, 2004.
177. Fanjin Zhang, Xiao Liu, Jie Tang, Yuxiao Dong, Peiran Yao, Jie Zhang, Xiaotao Gu, Yan Wang, Bin Shao, Rui Li, et al. Oag: Toward linking large-scale heterogeneous entity graphs. In *Proceedings of the 25th ACM SIGKDD International Conference on Knowledge Discovery & Data Mining*, pages 2585–2595, 2019.
178. Fabio Petroni, Aleksandra Piktus, Angela Fan, Patrick Lewis, Majid Yazdani, Nicola De Cao, James Thorne, Yacine Jernite, Vladimir Karpukhin, Jean Maillard, et al. Kilt: a benchmark for knowledge intensive language tasks. *arXiv preprint arXiv:2009.02252*, 2020.
179. Paolo Ferragina and Ugo Scaiella. Tagme: on-the-fly annotation of short text fragments (by wikipedia entities). In *Proceedings of the 19th ACM international conference on Information and knowledge management*, pages 1625–1628, 2010.
180. Matthew E Peters, Mark Neumann, Robert L Logan IV, Roy Schwartz, Vidur Joshi, Sameer Singh, and Noah A Smith. Knowledge enhanced contextual word representations. *arXiv preprint arXiv:1909.04164*, 2019.
181. Weijie Liu, Peng Zhou, Zhe Zhao, Zhiruo Wang, Qi Ju, Haotang Deng, and Ping Wang. K-bert: Enabling language representation with knowledge graph. In *Proceedings of the AAAI Conference on Artificial Intelligence*, volume 34, pages 2901–2908, 2020.
182. Thibault Févry, Livio Baldini Soares, Nicholas FitzGerald, Eunsol Choi, and Tom Kwiatkowski. Entities as experts: Sparse memory access with entity supervision. *arXiv preprint arXiv:2004.07202*, 2020.
183. Pat Verga, Haitian Sun, Livio Baldini Soares, and William W Cohen. Facts as experts: Adaptable and interpretable neural memory over symbolic knowledge. *arXiv preprint arXiv:2007.00849*, 2020.

184. Tianxiang Sun, Yunfan Shao, Xipeng Qiu, Qipeng Guo, Yaru Hu, Xuanjing Huang, and Zheng Zhang. Colake: Contextualized language and knowledge embedding. *arXiv preprint arXiv:2010.00309*, 2020.
185. Donghan Yu, Chenguang Zhu, Yiming Yang, and Michael Zeng. Jacket: Joint pre-training of knowledge graph and language understanding. *arXiv preprint arXiv:2010.00796*, 2020.
186. Yu Sun, Shuohuan Wang, Yukun Li, Shikun Feng, Xuyi Chen, Han Zhang, Xin Tian, Danxiang Zhu, Hao Tian, and Hua Wu. Ernie: Enhanced representation through knowledge integration. *arXiv preprint arXiv:1904.09223*, 2019.
187. Yu Sun, Shuohuan Wang, Shikun Feng, Siyu Ding, Chao Pang, Junyuan Shang, Jiayang Liu, Xuyi Chen, Yanbin Zhao, Yuxiang Lu, et al. Ernie 3.0: Large-scale knowledge enhanced pre-training for language understanding and generation. *arXiv preprint arXiv:2107.02137*, 2021.
188. Tao Shen, Yi Mao, Pengcheng He, Guodong Long, Adam Trischler, and Weizhu Chen. Exploiting structured knowledge in text via graph-guided representation learning. *arXiv preprint arXiv:2004.14224*, 2020.
189. Yujia Qin, Yankai Lin, Ryuichi Takanobu, Zhiyuan Liu, Peng Li, Heng Ji, Minlie Huang, Maosong Sun, and Jie Zhou. Erica: improving entity and relation understanding for pre-trained language models via contrastive learning. *arXiv preprint arXiv:2012.15022*, 2020.
190. Ting Chen, Simon Kornblith, Mohammad Norouzi, and Geoffrey Hinton. A simple framework for contrastive learning of visual representations. In *International conference on machine learning*, pages 1597–1607. PMLR, 2020.
191. Yangfeng Ji, Chenhao Tan, Sebastian Martschat, Yejin Choi, and Noah A Smith. Dynamic entity representations in neural language models. *arXiv preprint arXiv:1708.00781*, 2017.
192. Sungjin Ahn, Heeyoul Choi, Tanel Pärnamaa, and Yoshua Bengio. A neural knowledge language model. *arXiv preprint arXiv:1608.00318*, 2016.
193. Corby Rosset, Chenyan Xiong, Minh Phan, Xia Song, Paul Bennett, and Saurabh Tiwary. Knowledge-aware language model pretraining. *arXiv preprint arXiv:2007.00655*, 2020.
194. Liang Yao, Chengsheng Mao, and Yuan Luo. Kg-bert: Bert for knowledge graph completion. *arXiv preprint arXiv:1909.03193*, 2019.
195. Luc De Raedt, Kristian Kersting, Sriraam Natarajan, and David Poole. Statistical relational artificial intelligence: Logic, probability, and computation. *Synthesis Lectures on Artificial Intelligence and Machine Learning*, 10(2):1–189, 2016.
196. Dhiraj Kalamkar, Dheevatsa Mudigere, Naveen Mellempudi, Dipankar Das, Kunal Banerjee, Sasikanth Avancha, Dharma Teja Vooturi, Nataraj Jammalamadaka, Jianyu Huang, Hector Yuen, et al. A study of bfloat16 for deep learning training. *arXiv preprint arXiv:1905.12322*, 2019.
197. Andres Rodriguez, Eden Segal, Etay Meiri, Evarist Fomenko, Y Jim Kim, Haihao Shen, and Barukh Ziv. Lower numerical precision deep learning inference and training. *Intel White Paper*, 3:1–19, 2018.
198. Richard Todd Evans, Matthew Cawood, Stephen Lien Harrell, Lei Huang, Si Liu, Chun-Yaung Lu, Amit Ruhela, Yinzhi Wang, and Zhao Zhang. Optimizing gpu-enhanced hpc system and cloud procurements for scientific workloads. In *International Conference on High Performance Computing*, pages 313–331. Springer, 2021.
199. Yongwei Zhao, Chang Liu, Zidong Du, Qi Guo, Xing Hu, Yimin Zhuang, Zhenxing Zhang, Xinkai Song, Wei Li, Xishan Zhang, et al. Cambricon-q: a hybrid architecture for efficient training. In *2021 ACM/IEEE 48th Annual International Symposium on Computer Architecture (ISCA)*, pages 706–719. IEEE, 2021.
200. Dieuwertje Luitse and Wiebke Denkena. The great transformer: Examining the role of large language models in the political economy of ai. *Big Data & Society*, 8(2):205395172111047734, 2021.
201. Mohammad Shoeybi, Mostafa Patwary, Raul Puri, Patrick LeGresley, Jared Casper, and Bryan Catanzaro. Megatron-lm: Training multi-billion parameter language models using model parallelism. *arXiv preprint arXiv:1909.08053*, 2019.
202. Junyang Lin, Rui Men, An Yang, Chang Zhou, Ming Ding, Yichang Zhang, Peng Wang, Ang Wang, Le Jiang, Xianyan Jia, et al. M6: A chinese multimodal pretrainer. *arXiv preprint arXiv:2103.00823*, 2021.
203. An Yang, Junyang Lin, Rui Men, Chang Zhou, Le Jiang, Xianyan Jia, Ang Wang, Jie Zhang, Jiamang Wang, Yong Li, et al. Exploring sparse expert models and beyond. *arXiv preprint arXiv:2105.15082*, 2021.
204. Lee Harrison. Moore’s law meets shannon’s law: the evolution of the communication’s industry. In *Proceedings 2001 IEEE International Conference on Computer Design: VLSI in Computers and Processors. ICCD 2001*, pages 5–5. IEEE Computer Society, 2001.
205. Vijay Janapa Reddi, Christine Cheng, David Kanter, Peter Mattson, Guenther Schmuelling, Carole-Jean Wu, Brian Anderson, Maximilien Breughe, Mark Charlebois, William Chou, et al. Mlperf inference benchmark. In *2020 ACM/IEEE 47th Annual International Symposium on Computer Architecture (ISCA)*, pages 446–459. IEEE, 2020.
206. Tristan Schefke. Deepbench: Open-source tools for ai in the sky. Technical report, Fermi National Accelerator Lab.(FNAL), Batavia, IL (United States), 2020.
207. Wei Min Zhang, Long Zhang, Zheyu Zhang, and Mingjun Sun. Ibd: The metrics and evaluation method for dnn processor benchmark while doing inference task. *Journal of Intelligent & Fuzzy Systems*, (Preprint):1–13, 2021.
208. Shuhei Kudo, Keigo Nitadori, Takuya Ina, and Toshiyuki Imamura. Prompt report on exa-scale hpl-ai benchmark. In *2020 IEEE International Conference on Cluster Computing (CLUSTER)*, pages 418–419. IEEE, 2020.
209. Zhixiang Ren, Yongheng Liu, Tianhui Shi, Lei Xie, Yue Zhou, Jidong Zhai, Youhui Zhang, Yunquan Zhang, and Wenguang Chen. Aiperf: Automated machine learning as an ai-hpc benchmark. *Big Data Mining and Analytics*, 4(3):208–220, 2021.
210. Albert Reuther, Peter Michaleas, Michael Jones, Vijay Gadepally, Siddharth Samsi, and Jeremy Kepner. Ai accelerator survey and trends. In *2021 IEEE High Performance Extreme Computing Conference (HPEC)*, pages 1–9. IEEE, 2021.
211. MATTEO Presutto. Current ai trends: Hardware and software accelerators. *Royal Institute of Technology*, pages 1–21, 2018.



212. Jack Choquette and Wish Gandhi. Nvidia a100 gpu: Performance & innovation for gpu computing. In *2020 IEEE Hot Chips 32 Symposium (HCS)*, pages 1–43. IEEE Computer Society, 2020.
213. Zhen Zhang, Chaokun Chang, Haibin Lin, Yida Wang, Raman Arora, and Xin Jin. Is network the bottleneck of distributed training? In *Proceedings of the Workshop on Network Meets AI & ML*, pages 8–13, 2020.
214. Neil C Thompson, Kristjan Greenewald, Keeheon Lee, and Gabriel F Manso. The computational limits of deep learning. *arXiv preprint arXiv:2007.05558*, 2020.
215. Saif M Khan and Alexander Mann. Ai chips: What they are and why they matter. *Georgetown Center for Security and Emerging Technology, Tech. Rep*, 2020.
216. Karl Berggren, Qiangfei Xia, Konstantin K Likharev, Dmitri B Strukov, Hao Jiang, Thomas Mikolajick, Damien Querlioz, Martin Salinga, John R Erickson, Shuang Pi, et al. Roadmap on emerging hardware and technology for machine learning. *Nanotechnology*, 32(1):012002, 2020.
217. Stefan Hadjis, Ce Zhang, Ioannis Mitliagkas, Dan Iter, and Christopher Ré. Omnivore: An optimizer for multi-device deep learning on cpus and gpus. *arXiv preprint arXiv:1606.04487*, 2016.
218. Jinhui Yuan, Xinqi Li, Cheng Cheng, Juncheng Liu, Ran Guo, Shenghang Cai, Chi Yao, Fei Yang, Xiaodong Yi, Chuan Wu, et al. Oneflow: Redesign the distributed deep learning framework from scratch. *arXiv preprint arXiv:2110.15032*, 2021.
219. Yang Cheng, Dan Li, Zhiyuan Guo, Binyao Jiang, Jinkun Geng, Wei Bai, Jianping Wu, and Yongqiang Xiong. Accelerating end-to-end deep learning workflow with codesign of data preprocessing and scheduling. *IEEE Transactions on Parallel and Distributed Systems*, 32(7):1802–1814, 2020.
220. Samyam Rajbhandari, Jeff Rasley, Olatunji Ruwase, and Yuxiong He. Zero: Memory optimizations toward training trillion parameter models. In *SC20: International Conference for High Performance Computing, Networking, Storage and Analysis*, pages 1–16. IEEE, 2020.
221. Samira Abnar, Mostafa Dehghani, Behnam Neyshabur, and Hanie Sedghi. Exploring the limits of large scale pre-training. *arXiv preprint arXiv:2110.02095*, 2021.
222. Zhengyan Zhang, Xu Han, Hao Zhou, Pei Ke, Yuxian Gu, Deming Ye, Yujia Qin, Yusheng Su, Haozhe Ji, Jian Guan, et al. Cpm: A large-scale generative chinese pre-trained language model. *AI Open*, 2:93–99, 2021.
223. Linghao Song, Jiachen Mao, Youwei Zhuo, Xuehai Qian, Hai Li, and Yiran Chen. Hypar: Towards hybrid parallelism for deep learning accelerator array. In *2019 IEEE International Symposium on High Performance Computer Architecture (HPCA)*, pages 56–68. IEEE, 2019.
224. Neil C Thompson and Svenja Spanuth. The decline of computers as a general purpose technology. *Communications of the ACM*, 64(3):64–72, 2021.
225. Andrew Putnam, Adrian M Caulfield, Eric S Chung, Derek Chiou, Kypros Constantinides, John Demme, Hadi Esmaeilzadeh, Jeremy Fowers, Gopi Prashanth Gopal, Jan Gray, et al. A reconfigurable fabric for accelerating large-scale datacenter services. In *2014 ACM/IEEE 41st International Symposium on Computer Architecture (ISCA)*, pages 13–24. IEEE, 2014.
226. Dieter Ernst. Competing in artificial intelligence chips: China’s challenge amid technology war. *Centre for International Governance Innovation, Special Report*, 2020.
227. David So, Quoc Le, and Chen Liang. The evolved transformer. In *International Conference on Machine Learning*, pages 5877–5886. PMLR, 2019.
228. Danny Hernandez and Tom B Brown. Measuring the algorithmic efficiency of neural networks. *arXiv preprint arXiv:2005.04305*, 2020.
229. NVIDIA, Péter Vingelmann, and Frank H.P. Fitzek. Cuda, release: 10.2.89, 2020.
230. Sharan Chetlur, Cliff Woolley, Philippe Vandermersch, Jonathan Cohen, John Tran, Bryan Catanzaro, and Evan Shelhamer. cudnn: Efficient primitives for deep learning. *CoRR*, abs/1410.0759, 2014.
231. Yangqing Jia, Evan Shelhamer, Jeff Donahue, Sergey Karayev, Jonathan Long, Ross Girshick, Sergio Guadarrama, and Trevor Darrell. Caffe: Convolutional architecture for fast feature embedding. In *Proceedings of the 22nd ACM international conference on Multimedia*, pages 675–678, 2014.
232. Martín Abadi, Paul Barham, Jianmin Chen, Zhifeng Chen, Andy Davis, Jeffrey Dean, Matthieu Devin, Sanjay Ghemawat, Geoffrey Irving, Michael Isard, et al. Tensorflow: A system for large-scale machine learning. In *12th {USENIX} symposium on operating systems design and implementation ({OSDI} 16)*, pages 265–283, 2016.
233. Yanjun Ma, Dianhai Yu, Tian Wu, and Haifeng Wang. Paddlepaddle: An open-source deep learning platform from industrial practice. *Frontiers of Data and Computing*, 1(1):105–115, 2019.
234. Adam Paszke, Sam Gross, Francisco Massa, Adam Lerer, James Bradbury, Gregory Chanan, Trevor Killeen, Zeming Lin, Natalia Gimelshein, Luca Antiga, et al. Pytorch: An imperative style, high-performance deep learning library. *Advances in neural information processing systems*, 32:8026–8037, 2019.
235. Roy Frostig, Matthew James Johnson, and Chris Leary. Compiling machine learning programs via high-level tracing. *Systems for Machine Learning*, 2018.
236. Lei Chen. *Deep Learning and Practice with MindSpore*. Springer Nature, 2021.
237. Mu Li, Li Zhou, Zichao Yang, Aaron Li, Fei Xia, David G Andersen, and Alexander Smola. Parameter server for distributed machine learning. In *Big Learning NIPS Workshop*, volume 6, page 2, 2013.
238. Andrew D Birrell and Bruce Jay Nelson. Implementing remote procedure calls. *ACM Transactions on Computer Systems (TOCS)*, 2(1):39–59, 1984.

239. Alexander Sergeev and Mike Del Balso. Horovod: fast and easy distributed deep learning in tensorflow. *CoRR*, abs/1802.05799, 2018.
240. Priya Goyal, Piotr Dollár, Ross Girshick, Pieter Noordhuis, Lukasz Wesolowski, Aapo Kyrola, Andrew Tulloch, Yangqing Jia, and Kaiming He. Accurate, large minibatch sgd: Training imagenet in 1 hour. *arXiv preprint arXiv:1706.02677*, 2017.
241. Yang You, Zhao Zhang, Cho-Jui Hsieh, James Demmel, and Kurt Keutzer. Imagenet training in minutes. In *Proceedings of the 47th International Conference on Parallel Processing*, pages 1–10, 2018.
242. Xianyan Jia, Shutao Song, Wei He, Yangzihao Wang, Haidong Rong, Feihu Zhou, Liqiang Xie, Zhenyu Guo, Yuanzhou Yang, Liwei Yu, et al. Highly scalable deep learning training system with mixed-precision: Training imagenet in four minutes. *arXiv preprint arXiv:1807.11205*, 2018.
243. Peng Sun, Wansen Feng, Ruobing Han, Shengen Yan, and Yonggang Wen. Optimizing network performance for distributed dnn training on gpu clusters: Imagenet/alexnet training in 1.5 minutes. *arXiv preprint arXiv:1902.06855*, 2019.
244. Qinyi Luo, Jiaao He, Youwei Zhuo, and Xuehai Qian. Prague: High-performance heterogeneity-aware asynchronous decentralized training. In *Proceedings of the Twenty-Fifth International Conference on Architectural Support for Programming Languages and Operating Systems*, pages 401–416, 2020.
245. Shigang Li, Tal Ben-Nun, Salvatore Di Girolamo, Dan Alistarh, and Torsten Hoefler. Taming unbalanced training workloads in deep learning with partial collective operations. In *Proceedings of the 25th ACM SIGPLAN Symposium on Principles and Practice of Parallel Programming*, pages 45–61, 2020.
246. Giorgi Nadiradze, Amirmojtaba Sabour, Dan Alistarh, Aditya Sharma, Iliia Markov, and Vitaly Aksenov. Swarmsgd: Scalable decentralized sgd with local updates. *arXiv preprint arXiv:1910.12308*, 2019.
247. Yimin Jiang, Yibo Zhu, Chang Lan, Bairen Yi, Yong Cui, and Chuanxiong Guo. A unified architecture for accelerating distributed {DNN} training in heterogeneous gpu/cpu clusters. In *14th {USENIX} Symposium on Operating Systems Design and Implementation ({OSDI} 20)*, pages 463–479, 2020.
248. Jie Ren, Samyam Rajbhandari, Reza Yazdani Aminabadi, Olatunji Ruwase, Shuangyan Yang, Minjia Zhang, Dong Li, and Yuxiong He. Zero-offload: Democratizing billion-scale model training. *arXiv preprint arXiv:2101.06840*, 2021.
249. Samyam Rajbhandari, Olatunji Ruwase, Jeff Rasley, Shaden Smith, and Yuxiong He. Zero-infinity: Breaking the gpu memory wall for extreme scale deep learning. *arXiv preprint arXiv:2104.07857*, 2021.
250. Alex Krizhevsky. One weird trick for parallelizing convolutional neural networks. *arXiv preprint arXiv:1404.5997*, 2014.
251. Zhihao Jia, Matei Zaharia, and Alex Aiken. Beyond data and model parallelism for deep neural networks. *arXiv preprint arXiv:1807.05358*, 2018.
252. Minjie Wang, Chien-chin Huang, and Jinyang Li. Supporting very large models using automatic dataflow graph partitioning. In *Proceedings of the Fourteenth EuroSys Conference 2019*, pages 1–17, 2019.
253. Noam Shazeer, Youlong Cheng, Niki Parmar, Dustin Tran, Ashish Vaswani, Penporn Koanantakool, Peter Hawkins, HyoukJoong Lee, Mingsheng Hong, Cliff Young, et al. Mesh-tensorflow: Deep learning for supercomputers. *arXiv preprint arXiv:1811.02084*, 2018.
254. Dmitry Lepikhin, HyoukJoong Lee, Yuanzhong Xu, Dehao Chen, Orhan Firat, Yanping Huang, Maxim Krikun, Noam Shazeer, and Zhifeng Chen. Gshard: Scaling giant models with conditional computation and automatic sharding. *arXiv preprint arXiv:2006.16668*, 2020.
255. Yuanzhong Xu, HyoukJoong Lee, Dehao Chen, Blake Hechtman, Yanping Huang, Rahul Joshi, Maxim Krikun, Dmitry Lepikhin, Andy Ly, Marcello Maggioni, et al. Gspmd: General and scalable parallelization for ml computation graphs. *arXiv preprint arXiv:2105.04663*, 2021.
256. Zhengda Bian, Hongxin Liu, Boxiang Wang, Haichen Huang, Yongbin Li, Chuanrui Wang, Fan Cui, and Yang You. Colossal-ai: A unified deep learning system for large-scale parallel training. *arXiv preprint arXiv:2110.14883*, 2021.
257. Qifan Xu, Shenggui Li, Chaoyu Gong, and Yang You. An efficient 2d method for training super-large deep learning models. *arXiv preprint arXiv:2104.05343*, 2021.
258. Boxiang Wang, Qifan Xu, Zhengda Bian, and Yang You. 2.5-dimensional distributed model training. *arXiv preprint arXiv:2105.14500*, 2021.
259. Zhengda Bian, Qifan Xu, Boxiang Wang, and Yang You. Maximizing parallelism in distributed training for huge neural networks. *arXiv preprint arXiv:2105.14450*, 2021.
260. Yanping Huang, Youlong Cheng, Ankur Bapna, Orhan Firat, Dehao Chen, Mia Chen, HyoukJoong Lee, Jiquan Ngiam, Quoc V Le, Yonghui Wu, et al. Gpipe: Efficient training of giant neural networks using pipeline parallelism. *Advances in neural information processing systems*, 32:103–112, 2019.
261. Deepak Narayanan, Aaron Harlap, Amar Phanishayee, Vivek Seshadri, Nikhil R Devanur, Gregory R Ganger, Phillip B Gibbons, and Matei Zaharia. Pipedream: generalized pipeline parallelism for dnn training. In *Proceedings of the 27th ACM Symposium on Operating Systems Principles*, pages 1–15, 2019.
262. Deepak Narayanan, Amar Phanishayee, Kaiyu Shi, Xie Chen, and Matei Zaharia. Memory-efficient pipeline-parallel dnn training. In *International Conference on Machine Learning*, pages 7937–7947. PMLR, 2021.
263. Bowen Yang, Jian Zhang, Jonathan Li, Christopher Ré, Christopher Aberger, and Christopher De Sa. Pipemare: Asynchronous pipeline parallel dnn training. *Proceedings of Machine Learning and Systems*, 3, 2021.
264. Shiqing Fan, Yi Rong, Chen Meng, Zongyan Cao, Siyu Wang, Zhen Zheng, Chuan Wu, Guoping Long, Jun Yang, Lixue Xia, et al. Dapple: A pipelined data parallel approach for training large models. In *Proceedings of the 26th ACM SIGPLAN Symposium on Principles and Practice of Parallel Programming*, pages 431–445, 2021.

265. Zhuohan Li, Siyuan Zhuang, Shiyuan Guo, Danyang Zhuo, Hao Zhang, Dawn Song, and Ion Stoica. Terapipe: Token-level pipeline parallelism for training large-scale language models. *arXiv preprint arXiv:2102.07988*, 2021.
266. Mike Lewis, Shruti Bhosale, Tim Dettmers, Naman Goyal, and Luke Zettlemoyer. Base layers: Simplifying training of large, sparse models. *arXiv preprint arXiv:2103.16716*, 2021.
267. Jiaao He, Jiezhong Qiu, Aohan Zeng, Zhilin Yang, Jidong Zhai, and Jie Tang. Fastmoe: A fast mixture-of-expert training system. *arXiv preprint arXiv:2103.13262*, 2021.
268. William Fedus, Barret Zoph, and Noam Shazeer. Switch transformers: Scaling to trillion parameter models with simple and efficient sparsity. *arXiv preprint arXiv:2101.03961*, 2021.
269. PyTorch Contributors. Torch script, 2021.
270. Paresh Kharya. Tensorfloat-32 in the a100 gpu accelerates ai training, hpc up to 20x. *the NVIDIA Blog*, 2020.
271. Shibo Wang and Pankaj Kanwar. Bfloat16: the secret to high performance on cloud tpus. *Google Cloud Blog*, 2019.
272. Norman P Jouppi, Cliff Young, Nishant Patil, David Patterson, Gaurav Agrawal, Raminder Bajwa, Sarah Bates, Suresh Bhatia, Nan Boden, Al Borchers, et al. In-datacenter performance analysis of a tensor processing unit. In *Proceedings of the 44th annual international symposium on computer architecture*, pages 1–12, 2017.
273. Youjie Li, Iou-Jen Liu, Yifan Yuan, Deming Chen, Alexander Schwing, and Jian Huang. Accelerating distributed reinforcement learning with in-switch computing. In *2019 ACM/IEEE 46th Annual International Symposium on Computer Architecture (ISCA)*, pages 279–291. IEEE, 2019.
274. Christopher Manning and Hinrich Schütze. *Foundations of statistical natural language processing*. MIT press, 1999.
275. Yoshua Bengio, Réjean Ducharme, Pascal Vincent, and Christian Jauvin. A neural probabilistic language model. *Journal of machine learning research*, 3(Feb):1137–1155, 2003.
276. Rico Sennrich, Barry Haddow, and Alexandra Birch. Neural machine translation of rare words with subword units. In *Proceedings of ACL*, pages 1715–1725, 2016.
277. Yoon Kim. Convolutional neural networks for sentence classification. In *Proceedings of EMNLP*, pages 1746–1751, 2014.
278. Xiang Zhang, Junbo Zhao, and Yann LeCun. Character-level convolutional networks for text classification. *Proceedings of NeurIPS*, 28:649–657, 2015.
279. Baotian Hu, Zhengdong Lu, Hang Li, and Qingcai Chen. Convolutional neural network architectures for matching natural language sentences. In *Proceedings of NeurIPS*, pages 2042–2050, 2014.
280. Sepp Hochreiter and Jürgen Schmidhuber. Long short-term memory. *Neural computation*, 9(8):1735–1780, 1997.
281. Junyoung Chung, Caglar Gulcehre, KyungHyun Cho, and Yoshua Bengio. Empirical evaluation of gated recurrent neural networks on sequence modeling. *arXiv preprint arXiv:1412.3555*, 2014.
282. Jimmy Lei Ba, Jamie Ryan Kiros, and Geoffrey E Hinton. Layer normalization. *arXiv preprint arXiv:1607.06450*, 2016.
283. Vinod Nair and Geoffrey E Hinton. Rectified linear units improve restricted boltzmann machines. In *Proceedings of the 27th International Conference on International Conference on Machine Learning*, pages 807–814, 2010.
284. Dan Hendrycks and Kevin Gimpel. Gaussian error linear units (gelus). *arXiv preprint arXiv:1606.08415*, 2016.
285. Richard Socher, Alex Perelygin, Jean Wu, Jason Chuang, Christopher D Manning, Andrew Y Ng, and Christopher Potts. Recursive deep models for semantic compositionality over a sentiment treebank. In *Proceedings of EMNLP*, pages 1631–1642, 2013.
286. Kai Sheng Tai, Richard Socher, and Christopher D Manning. Improved semantic representations from tree-structured long short-term memory networks. In *Proceedings of ACL*, pages 1556–1566, 2015.
287. Xiaodan Zhu, Parinaz Sobihani, and Hongyu Guo. Long short-term memory over recursive structures. In *Proceedings of ICML*, pages 1604–1612. PMLR, 2015.
288. Kevin Clark, Minh-Thang Luong, Quoc V Le, and Christopher D Manning. Electra: Pre-training text encoders as discriminators rather than generators. In *Proceedings of ICLR*, 2019.
289. Mike Lewis, Yinhan Liu, Naman Goyal, Marjan Ghazvininejad, Abdelrahman Mohamed, Omer Levy, Veselin Stoyanov, and Luke Zettlemoyer. Bart: Denoising sequence-to-sequence pre-training for natural language generation, translation, and comprehension. In *Proceedings of the 58th Annual Meeting of the Association for Computational Linguistics*, pages 7871–7880, 2020.
290. Matthew E Peters, Mark Neumann, Mohit Iyyer, Matt Gardner, Christopher Clark, Kenton Lee, and Luke Zettlemoyer. Deep contextualized word representations. In *NAACL*, pages 2227–2237, 2018.
291. Alex Wang, Amanpreet Singh, Julian Michael, Felix Hill, Omer Levy, and Samuel Bowman. Glue: A multi-task benchmark and analysis platform for natural language understanding. In *Proceedings of the 2018 EMNLP Workshop BlackboxNLP: Analyzing and Interpreting Neural Networks for NLP*, pages 353–355, 2018.
292. Yinhan Liu, Myle Ott, Naman Goyal, Jingfei Du, Mandar Joshi, Danqi Chen, Omer Levy, Mike Lewis, Luke Zettlemoyer, and Veselin Stoyanov. Roberta: A robustly optimized bert pretraining approach. *arXiv preprint arXiv:1907.11692*, 2019.
293. Victor Sanh, Lysandre Debut, Julien Chaumond, and Thomas Wolf. DistilBERT, a distilled version of BERT: smaller, faster, cheaper and lighter. *arXiv preprint 1910.01108*, October 2019.
294. Zhenzhong Lan, Mingda Chen, Sebastian Goodman, Kevin Gimpel, Piyush Sharma, and Radu Soricut. Albert: A lite bert for self-supervised learning of language representations. *arXiv preprint arXiv:1909.11942*, 2019.
295. Xiaoqi Jiao, Yichun Yin, Lifeng Shang, Xin Jiang, Xiao Chen, Linlin Li, Fang Wang, and Qun Liu. TinyBERT: Distilling BERT for natural language understanding. In *Findings of EMNLP*, pages 4163–4174, 2020.
296. Zihang Dai, Zhilin Yang, Yiming Yang, Jaime G Carbonell, Quoc Le, and Ruslan Salakhutdinov. Transformer-xl: Attentive language models beyond a fixed-length context. In *Proceedings of the 57th Annual Meeting of the Association for Computational Linguistics*, pages 2978–2988, 2019.

297. Nikita Kitaev, Łukasz Kaiser, and Anselm Levskaya. Reformer: The efficient transformer. *arXiv preprint arXiv:2001.04451*, 2020.
298. Zhilin Yang, Zihang Dai, Yiming Yang, Jaime Carbonell, Russ R Salakhutdinov, and Quoc V Le. Xlnet: Generalized autoregressive pretraining for language understanding. *Advances in neural information processing systems*, 32, 2019.
299. Jingqing Zhang, Yao Zhao, Mohammad Saleh, and Peter Liu. Pegasus: Pre-training with extracted gap-sentences for abstractive summarization. In *International Conference on Machine Learning*, pages 11328–11339. PMLR, 2020.
300. Weizhen Qi, Yu Yan, Yeyun Gong, Dayiheng Liu, Nan Duan, Jiusheng Chen, Ruofei Zhang, and Ming Zhou. Prophetnet: Predicting future n-gram for sequence-to-sequence pre-training. In *Proceedings of the 2020 Conference on Empirical Methods in Natural Language Processing: Findings*, pages 2401–2410, 2020.
301. Mandar Joshi, Danqi Chen, Yinhan Liu, Daniel S Weld, Luke Zettlemoyer, and Omer Levy. Spanbert: Improving pre-training by representing and predicting spans. *Transactions of the Association for Computational Linguistics*, 8:64–77, 2020.
302. Pengcheng He, Xiaodong Liu, Jianfeng Gao, and Weizhu Chen. Deberta: Decoding-enhanced bert with disentangled attention. *arXiv preprint arXiv:2006.03654*, 2020.
303. Li Dong, Nan Yang, Wenhui Wang, Furu Wei, Xiaodong Liu, Yu Wang, Jianfeng Gao, Ming Zhou, and Hsiao-Wuen Hon. Unified language model pre-training for natural language understanding and generation. In *Advances in Neural Information Processing Systems*, pages 13042–13054, 2019.
304. Guillaume Lample and Alexis Conneau. Cross-lingual language model pretraining. *arXiv preprint arXiv:1901.07291*, 2019.
305. Zhengyan Zhang, Yuxian Gu, Xu Han, Shengqi Chen, Chaojun Xiao, Zhenbo Sun, Yuan Yao, Fanchao Qi, Jian Guan, Pei Ke, Yanzheng Cai, Guoyang Zeng, Zhixing Tan, Zhiyuan Liu, Minlie Huang, Wentao Han, Yang Liu, Xiaoyan Zhu, and Maosong Sun. Cpm-2: Large-scale cost-efficient pre-trained language models. 2021.
306. Linting Xue, Noah Constant, Adam Roberts, Mihir Kale, Rami Al-Rfou, Aditya Siddhant, Aditya Barua, and Colin Raffel. mt5: A massively multilingual pre-trained text-to-text transformer. In *Proceedings of the 2021 Conference of the North American Chapter of the Association for Computational Linguistics: Human Language Technologies*, pages 483–498, 2021.
307. Linting Xue, Aditya Barua, Noah Constant, Rami Al-Rfou, Sharan Narang, Mihir Kale, Adam Roberts, and Colin Raffel. Byt5: Towards a token-free future with pre-trained byte-to-byte models. *arXiv preprint arXiv:2105.13626*, 2021.
308. Mindspore-Ai. Mindspore-ai/mindspore: Mindspore is a new open source deep learning training/inference framework that could be used for mobile, edge and cloud scenarios.
309. Thomas Wolf, Julien Chaumond, Lysandre Debut, Victor Sanh, Clement Delangue, Anthony Moi, Pierric Cistac, Morgan Funtowicz, Joe Davison, Sam Shleifer, et al. Transformers: State-of-the-art natural language processing. In *Proceedings of the 2020 Conference on Empirical Methods in Natural Language Processing: System Demonstrations*, pages 38–45, 2020.
310. NVIDIA. Fastertransformer.
311. Jeff Rasley, Samyam Rajbhandari, Olatunji Ruwase, and Yuxiong He. Deepspeed: System optimizations enable training deep learning models with over 100 billion parameters. In *Proceedings of the 26th ACM SIGKDD International Conference on Knowledge Discovery & Data Mining*, pages 3505–3506, 2020.
312. Mandeep Baines, Shruti Bhosale, Vittorio Caggiano, Naman Goyal, Siddharth Goyal, Myle Ott, Benjamin Lefaudeux, Vitaliy Liptchinsky, Mike Rabbat, Sam Sheiffer, Anjali Sridhar, and Min Xu. Fairscale: A general purpose modular pytorch library for high performance and large scale training. <https://github.com/facebookresearch/fairscale>, 2021.
313. Ning Ding, Shengding Hu, Weilin Zhao, Yulin Chen, Zhiyuan Liu, Hai-Tao Zheng, and Maosong Sun. Openprompt: An open-source framework for prompt-learning. *arXiv preprint arXiv:2111.01998*, 2021.
314. OpenBMB. Bminf (big model inference) is a low-resource inference package for large-scale pretrained language models (plms).
315. Timo Schick and Hinrich Schütze. Exploiting cloze questions for few shot text classification and natural language inference. *arXiv preprint arXiv:2001.07676*, 2020.
316. Pengfei Liu, Weizhe Yuan, Jinlan Fu, Zhengbao Jiang, Hiroaki Hayashi, and Graham Neubig. Pre-train, prompt, and predict: A systematic survey of prompting methods in natural language processing. *arXiv preprint arXiv:2107.13586*, 2021.
317. Teven Le Scao and Alexander M Rush. How many data points is a prompt worth? In *Proceedings of the 2021 Conference of the North American Chapter of the Association for Computational Linguistics: Human Language Technologies*, pages 2627–2636, 2021.
318. Tianyu Gao, Adam Fisch, and Danqi Chen. Making pre-trained language models better few-shot learners. *arXiv preprint arXiv:2012.15723*, 2020.
319. Xiao Liu, Yanan Zheng, Zhengxiao Du, Ming Ding, Yujie Qian, Zhilin Yang, and Jie Tang. Gpt understands, too. *arXiv preprint arXiv:2103.10385*, 2021.
320. Taylor Shin, Yasaman Razeghi, Robert L Logan IV, Eric Wallace, and Sameer Singh. Autoprompt: Eliciting knowledge from language models with automatically generated prompts. *arXiv preprint arXiv:2010.15980*, 2020.
321. Shengding Hu, Ning Ding, Huadong Wang, Zhiyuan Liu, Juanzi Li, and Maosong Sun. Knowledgeable prompt-tuning: Incorporating knowledge into prompt verbalizer for text classification. *arXiv preprint arXiv:2108.02035*, 2021.
322. Ning Ding, Yulin Chen, Xu Han, Guangwei Xu, Pengjun Xie, Hai-Tao Zheng, Zhiyuan Liu, Juanzi Li, and Hong-Gee Kim. Prompt-learning for fine-grained entity typing. *arXiv preprint arXiv:2108.10604*, 2021.

323. Chujie Zheng and Minlie Huang. Exploring prompt-based few-shot learning for grounded dialog generation. *arXiv preprint arXiv:2109.06513*, 2021.
324. Neil Houlsby, Andrei Giurgiu, Stanislaw Jastrzebski, Bruna Morrone, Quentin De Laroussilhe, Andrea Gesmundo, Mona Attariyan, and Sylvain Gelly. Parameter-efficient transfer learning for nlp. In *International Conference on Machine Learning*, pages 2790–2799. PMLR, 2019.
325. Jonas Pfeiffer, Aishwarya Kamath, Andreas Rücklé, Kyunghyun Cho, and Iryna Gurevych. Adapterfusion: Non-destructive task composition for transfer learning. *arXiv preprint arXiv:2005.00247*, 2020.
326. Jonas Pfeiffer, Andreas Rücklé, Clifton Poth, Aishwarya Kamath, Ivan Vulić, Sebastian Ruder, Kyunghyun Cho, and Iryna Gurevych. Adapterhub: A framework for adapting transformers. *arXiv preprint arXiv:2007.07779*, 2020.
327. Brian Lester, Rami Al-Rfou, and Noah Constant. The power of scale for parameter-efficient prompt tuning. *arXiv preprint arXiv:2104.08691*, 2021.
328. Yuxian Gu, Xu Han, Zhiyuan Liu, and Minlie Huang. Ppt: Pre-trained prompt tuning for few-shot learning. *arXiv preprint arXiv:2109.04332*, 2021.
329. Yujia Qin, Xiaozhi Wang, Yusheng Su, Yankai Lin, Ning Ding, Zhiyuan Liu, Juanzi Li, Lei Hou, Peng Li, Maosong Sun, et al. Exploring low-dimensional intrinsic task subspace via prompt tuning. *arXiv preprint arXiv:2110.07867*, 2021.
330. Edward J Hu, Yelong Shen, Phillip Wallis, Zeyuan Allen-Zhu, Yuanzhi Li, Shean Wang, Lu Wang, and Weizhu Chen. Lora: Low-rank adaptation of large language models. *arXiv preprint arXiv:2106.09685*, 2021.
331. Demi Guo, Alexander M Rush, and Yoon Kim. Parameter-efficient transfer learning with diff pruning. *arXiv preprint arXiv:2012.07463*, 2020.
332. Jeffrey O Zhang, Alexander Sax, Amir Zamir, Leonidas Guibas, and Jitendra Malik. Side-tuning: A baseline for network adaptation via additive side networks. In *Computer Vision–ECCV 2020: 16th European Conference, Glasgow, UK, August 23–28, 2020, Proceedings, Part III 16*, pages 698–714. Springer, 2020.
333. Yuning Mao, Lambert Mathias, Rui Hou, Amjad Almahairi, Hao Ma, Jiawei Han, Wen-tau Yih, and Madian Khabsa. Unipelt: A unified framework for parameter-efficient language model tuning. *arXiv preprint arXiv:2110.07577*, 2021.
334. Junxian He, Chunting Zhou, Xuezhe Ma, Taylor Berg-Kirkpatrick, and Graham Neubig. Towards a unified view of parameter-efficient transfer learning. *arXiv preprint arXiv:2110.04366*, 2021.
335. Andrew Maas, Raymond E Daly, Peter T Pham, Dan Huang, Andrew Y Ng, and Christopher Potts. Learning word vectors for sentiment analysis. In *Proceedings of NAACL-HLT*, pages 142–150, 2011.
336. Bill MacCartney and Christopher D Manning. Modeling semantic containment and exclusion in natural language inference. In *Proceedings of COLING*, pages 521–528, 2008.
337. Qian Chen, Xiaodan Zhu, Zhen-Hua Ling, Si Wei, Hui Jiang, and Diana Inkpen. Enhanced LSTM for natural language inference. In *Proceedings of ACL*, pages 1657–1668, 2017.
338. Yifan Qiao, Chenyan Xiong, Zhenghao Liu, and Zhiyuan Liu. Understanding the behaviors of bert in ranking. *arXiv preprint arXiv:1904.07531*, 2019.
339. Nils Reimers, Iryna Gurevych, Nils Reimers, Iryna Gurevych, Nandan Thakur, Nils Reimers, Johannes Daxenberger, Iryna Gurevych, Nils Reimers, Iryna Gurevych, et al. Sentence-bert: Sentence embeddings using siamese bert-networks. In *Proceedings of EMNLP*. Association for Computational Linguistics, 2019.
340. Jiafeng Guo, Yixing Fan, Liang Pang, Liu Yang, Qingyao Ai, Hamed Zamani, Chen Wu, W Bruce Croft, and Xueqi Cheng. A deep look into neural ranking models for information retrieval. *Information Processing & Management*, 57(6):102067, 2020.
341. Zhuyun Dai and Jamie Callan. Deeper text understanding for IR with contextual neural language modeling. In *Proceedings of SIGIR*, pages 985–988, 2019.
342. Rie Johnson and Tong Zhang. Effective use of word order for text categorization with convolutional neural networks. In *Proceedings of NAACL-NLT*, pages 103–112, 2015.
343. Tianda Li, Xiaodan Zhu, Quan Liu, Qian Chen, Zhigang Chen, and Si Wei. Several experiments on investigating pretraining and knowledge-enhanced models for natural language inference. *arXiv preprint arXiv:1904.12104*, 2019.
344. Xinlei Chen and Kaiming He. Exploring simple siamese representation learning. In *Proceedings of the IEEE/CVF Conference on Computer Vision and Pattern Recognition*, pages 15750–15758, 2021.
345. Yuanmeng Yan, Rumei Li, Sirui Wang, Fuzheng Zhang, Wei Wu, and Weiran Xu. Consert: A contrastive framework for self-supervised sentence representation transfer. In *Proceedings of ACL-IJCNLP*, pages 5065–5075, 2021.
346. Jun Gao, Di He, Xu Tan, Tao Qin, Liwei Wang, and Tie-Yan Liu. Representation degeneration problem in training natural language generation models. *arXiv preprint arXiv:1907.12009*, 2019.
347. Bohan Li, Hao Zhou, Junxian He, Mingxuan Wang, Yiming Yang, and Lei Li. On the sentence embeddings from pre-trained language models. *Proceedings of EMNLP*, 2020.
348. Shuqi Lu, Chenyan Xiong, Di He, Guolin Ke, Waleed Malik, Zhicheng Dou, Paul Bennett, Tieyan Liu, and Arnold Overwijk. Less is more: Pre-training a strong siamese encoder using a weak decoder. *arXiv preprint arXiv:2102.09206*, 2021.
349. Hongchao Fang, Sicheng Wang, Meng Zhou, Jiayuan Ding, and Pengtao Xie. Cert: Contrastive self-supervised learning for language understanding. *arXiv preprint arXiv:2005.12766*, 2020.
350. Zhuofeng Wu, Sinong Wang, Jiatao Gu, Madian Khabsa, Fei Sun, and Hao Ma. Clear: Contrastive learning for sentence representation. *arXiv preprint arXiv:2012.15466*, 2020.
351. Yu Meng, Chenyan Xiong, Payal Bajaj, Saurabh Tiwary, Paul Bennett, Jiawei Han, and Xia Song. Coco-lm: Correcting and contrasting text sequences for language model pretraining. *arXiv preprint arXiv:2102.08473*, 2021.

352. Tianyu Gao, Xingcheng Yao, and Danqi Chen. Simcse: Simple contrastive learning of sentence embeddings. *arXiv preprint arXiv:2104.08821*, 2021.
353. Ekin D Cubuk, Barret Zoph, Dandelion Mane, Vijay Vasudevan, and Quoc V Le. Autoaugment: Learning augmentation policies from data. *arXiv preprint arXiv:1805.09501*, 2018.
354. Ekin D Cubuk, Barret Zoph, Jonathon Shlens, and Quoc V Le. Randaugment: Practical automated data augmentation with a reduced search space. In *Proceedings of the IEEE/CVF Conference on Computer Vision and Pattern Recognition Workshops*, pages 702–703, 2020.
355. Luyu Gao and Jamie Callan. Condenser: a pre-training architecture for dense retrieval. In *Proceedings of EMNLP*, pages 981–993, 2021.
356. Sewon Min, Mike Lewis, Hannaneh Hajishirzi, and Luke Zettlemoyer. Noisy channel language model prompting for few-shot text classification. *arXiv preprint arXiv:2108.04106*, 2021.
357. Yi Luan, Jacob Eisenstein, Kristina Toutanova, and Michael Collins. Sparse, dense, and attentional representations for text retrieval. *arXiv preprint arXiv:2005.00181*, 2020.
358. Vladimir Karpukhin, Barlas Oğuz, Sewon Min, Ledell Wu, Sergey Edunov, Danqi Chen, and Wen-tau Yih. Dense passage retrieval for open-domain question answering. *arXiv preprint arXiv:2004.04906*, 2020.
359. Luyu Gao, Zhuyun Dai, and Jamie Callan. Rethink training of bert rerankers in multi-stage retrieval pipeline. *arXiv preprint arXiv:2101.08751*, 2021.
360. Lee Xiong, Chenyan Xiong, Ye Li, Kwok-Fung Tang, Jialin Liu, Paul Bennett, Junaid Ahmed, and Arnold Overwijk. Approximate nearest neighbor negative contrastive learning for dense text retrieval. *arXiv preprint arXiv:2007.00808*, 2020.
361. Ruizhi Pu, Xinyu Zhang, Ruofei Lai, Zikai Guo, Yinxia Zhang, Hao Jiang, Yongkang Wu, Yantao Jia, Zhicheng Dou, and Zhao Cao. Yes sir! optimizing semantic space of negatives with self-involvement ranker. *arXiv preprint arXiv:2109.06436*, 2021.
362. Joshua Robinson, Ching-Yao Chuang, Suvrit Sra, and Stefanie Jegelka. Contrastive learning with hard negative samples. In *ICLR*, 2021.
363. Tongzhou Wang and Phillip Isola. Understanding contrastive representation learning through alignment and uniformity on the hypersphere, 2020.
364. Yizhi Li, Zhenghao Liu, Chenyan Xiong, and Zhiyuan Liu. More robust dense retrieval with contrastive dual learning. In *Proceedings of SIGIR*, pages 287–296, 2021.
365. Sebastian Hofstätter, Hamed Zamani, Bhaskar Mitra, Nick Craswell, and Allan Hanbury. Local self-attention over long text for efficient document retrieval. In *Proceedings of SIGIR*, page 2021–2024, 2020.
366. Nick Craswell, Bhaskar Mitra, Emine Yilmaz, Daniel Campos, and Ellen M Voorhees. Overview of the TREC 2019 deep learning track. *arXiv preprint arXiv:2003.07820*, 2020.
367. Yukun Zheng, Yiqun Liu, Zhi-Qiang Fan, Cheng Luo, Qingyao Ai, Min Zhang, and Shaoping Ma. Investigating weak supervision in deep ranking. *Data and Information Management*, 3:155 – 164, 2019.
368. Mostafa Dehghani, Hamed Zamani, Aliaksei Severyn, Jaap Kamps, and W Bruce Croft. Neural ranking models with weak supervision. In *Proceedings of SIGIR*, pages 65–74, 2017.
369. Shi Yu, Jiahua Liu, Jingqin Yang, Chenyan Xiong, Paul Bennett, Jianfeng Gao, and Zhiyuan Liu. Few-shot generative conversational query rewriting. *Proceedings of SIGIR*, page 1933–1936, 2021.
370. Sean MacAvaney, Andrew Yates, Kai Hui, and Ophir Frieder. Content-based weak supervision for ad-hoc re-ranking. In *Proceedings of SIGIR*, pages 993–996, 2019.
371. Kaitao Zhang, Chenyan Xiong, Zhenghao Liu, and Zhiyuan Liu. Selective weak supervision for neural information retrieval. In *Proceedings of WebConf*, pages 474–485, 2020.
372. Ji Ma, Ivan Korotkov, Yinfei Yang, Keith Hall, and Ryan McDonald. Zero-shot neural passage retrieval via domain-targeted synthetic question generation. In *Proceedings of the 16th Conference of the European Chapter of the Association for Computational Linguistics: Main Volume*, pages 1075–1088, 2021.
373. Si Sun, Yingzhuo Qian, Zhenghao Liu, Chenyan Xiong, Kaitao Zhang, Jie Bao, Zhiyuan Liu, and Paul Bennett. Few-shot text ranking with meta adapted synthetic weak supervision. In *Proceedings of ACL-IJCNLP*, pages 5030–5043, 2021.
374. Bo Han, Quanming Yao, Xingrui Yu, Gang Niu, Miao Xu, Weihua Hu, Ivor W. Tsang, and Masashi Sugiyama. Co-teaching: Robust training of deep neural networks with extremely noisy labels. In *Proceedings of NeurIPS*, pages 8536–8546, 2018.
375. Mengye Ren, Wenyuan Zeng, Bin Yang, and Raquel Urtasun. Learning to reweight examples for robust deep learning. In *Proceedings of ICML*, pages 4331–4340, 2018.
376. Dan Hendrycks, Mantas Mazeika, Duncan Wilson, and Kevin Gimpel. Using trusted data to train deep networks on labels corrupted by severe noise. In *Proceedings of NeurIPS*, pages 10477–10486, 2018.
377. Guillaume Lample, Miguel Ballesteros, Sandeep Subramanian, Kazuya Kawakami, and Chris Dyer. Neural architectures for named entity recognition. *arXiv preprint arXiv:1603.01360*, 2016.
378. Hanna M Wallach. Conditional random fields: An introduction. *Technical Reports (CIS)*, page 22, 2004.
379. John D. Lafferty, Andrew McCallum, and Fernando C. N. Pereira. Conditional random fields: Probabilistic models for segmenting and labeling sequence data. In *Proceedings of ICML*, pages 282–289, 2001.
380. Tianxiang Sun, Xiangyang Liu, Xipeng Qiu, and Xuanjing Huang. Paradigm shift in natural language processing. *arXiv preprint arXiv:2109.12575*, 2021.
381. Jana Straková, Milan Straka, and Jan Hajič. Neural architectures for nested ner through linearization. *arXiv preprint arXiv:1908.06926*, 2019.

382. Ming Yan, Chenliang Li, Bin Bi, Wei Wang, and Songfang Huang. A unified pretraining framework for passage ranking and expansion. In *Proceedings of the AAAI Conference on Artificial Intelligence*, volume 35, pages 4555–4563, 2021.
383. Ruotian Ma, Xin Zhou, Tao Gui, Yiding Tan, Qi Zhang, and Xuanjing Huang. Template-free prompt tuning for few-shot ner. *arXiv preprint arXiv:2109.13532*, 2021.
384. Robert F Simmons. Answering english questions by computer: a survey. *Communications of the ACM*, 8(1):53–70, 1965.
385. Ellen M Voorhees et al. The trec-8 question answering track report. In *Trec*, volume 99, pages 77–82. Citeseer, 1999.
386. Guokun Lai, Qizhe Xie, Hanxiao Liu, Yiming Yang, and Eduard Hovy. Race: Large-scale reading comprehension dataset from examinations. In *Proceedings of EMNLP*, pages 785–794, 2017.
387. Pranav Rajpurkar, Jian Zhang, Konstantin Lopyrev, and Percy Liang. Squad: 100,000+ questions for machine comprehension of text. In *Proceedings of EMNLP*, pages 2383–2392, 2016.
388. Felix Hill, Antoine Bordes, Sumit Chopra, and Jason Weston. The goldilocks principle: Reading children’s books with explicit memory representations. *arXiv preprint arXiv:1511.02301*, 2015.
389. Minjoon Seo, Aniruddha Kembhavi, Ali Farhadi, and Hannaneh Hajishirzi. Bidirectional attention flow for machine comprehension. *arXiv preprint arXiv:1611.01603*, 2016.
390. Robin Jia and Percy Liang. Adversarial examples for evaluating reading comprehension systems. In *Proceedings of EMNLP*, pages 2021–2031, 2017.
391. Todor Mihaylov and Anette Frank. Knowledgeable reader: Enhancing cloze-style reading comprehension with external commonsense knowledge. In *Proceedings of ACL*, pages 821–832, 2018.
392. Deming Ye, Yankai Lin, Jiaju Du, Zhenghao Liu, Peng Li, Maosong Sun, and Zhiyuan Liu. Coreferential reasoning learning for language representation. In *Proceedings of the 2020 Conference on Empirical Methods in Natural Language Processing (EMNLP)*, pages 7170–7186, 2020.
393. Adam Roberts, Colin Raffel, and Noam Shazeer. How much knowledge can you pack into the parameters of a language model? In *Proceedings of EMNLP*, pages 5418–5426, 2020.
394. Iz Beltagy, Arman Cohan, Hannaneh Hajishirzi, Sewon Min, and Matthew Peters. Beyond paragraphs: Nlp for long sequences. In *Proceedings of NAACL: Tutorials*, pages 20–24, 2021.
395. Christopher Clark and Matt Gardner. Simple and effective multi-paragraph reading comprehension. In *Proceedings of the ACL*, pages 845–855, 2018.
396. Minghao Hu, Furu Wei, Yuxing Peng, Zhen Huang, Nan Yang, and Dongsheng Li. Read+ verify: Machine reading comprehension with unanswerable questions. In *Proceedings AAAI*, pages 6529–6537, 2019.
397. Haichao Zhu, Li Dong, Furu Wei, Wenhui Wang, Bing Qin, and Ting Liu. Learning to ask unanswerable questions for machine reading comprehension. In *Proceedings of ACL*, pages 4238–4248, 2019.
398. Mark Yatskar. A qualitative comparison of coqa, squad 2.0 and quac. In *Proceedings of EMNLP*, pages 2318–2323, 2019.
399. Akari Asai and Eunsol Choi. Challenges in information seeking qa: Unanswerable questions and paragraph retrieval. *arXiv preprint arXiv:2010.11915*, 2020.
400. Zhuosheng Zhang, Junjie Yang, and Hai Zhao. Retrospective reader for machine reading comprehension.
401. Seohyun Back, Sai Chetan Chinthakindi, Akhil Kedia, Haejun Lee, and Jaegul Choo. Neurquri: Neural question requirement inspector for answerability prediction in machine reading comprehension. In *Proceedings of ICLR*, 2019.
402. Najoung Kim, Ellie Pavlick, Burcu Karagol Ayan, and Deepak Ramachandran. Which linguist invented the lightbulb? presupposition verification for question-answering. *arXiv preprint arXiv:2101.00391*, 2021.
403. Zhenghao Liu, Chenyan Xiong, Maosong Sun, and Zhiyuan Liu. Fine-grained fact verification with kernel graph attention network. In *Proceedings of ACL*, pages 7342–7351, 2020.
404. James Thorne, Andreas Vlachos, Christos Christodoulopoulos, and Arpit Mittal. FEVER: a large-scale dataset for fact extraction and VERification. In *Proceedings of NAACL*, pages 809–819, 2018.
405. Danqi Chen, Adam Fisch, Jason Weston, and Antoine Bordes. Reading wikipedia to answer open-domain questions. In *Proceedings of ACL*, pages 1870–1879, 2017.
406. Yankai Lin, Haozhe Ji, Zhiyuan Liu, and Maosong Sun. Denoising distantly supervised open-domain question answering. In *Proceedings of ACL*, pages 1736–1745, 2018.
407. Wenhao Xiong, Xiang Lorraine Li, Srinivasan Iyer, Jingfei Du, Patrick S. H. Lewis, William Yang Wang, Yashar Mehdad, Wen-tau Yih, Sebastian Riedel, Douwe Kiela, and Barlas Oguz. Answering complex open-domain questions with multi-hop dense retrieval. *CoRR*, abs/2009.12756, 2020.
408. Patrick Lewis, Ethan Perez, Aleksandra Piktus, Fabio Petroni, Vladimir Karpukhin, Naman Goyal, Heinrich Küttler, Mike Lewis, Wen-tau Yih, Tim Rocktäschel, et al. Retrieval-augmented generation for knowledge-intensive nlp tasks. *arXiv preprint arXiv:2005.11401*, 2020.
409. Gautier Izacard and Édouard Grave. Leveraging passage retrieval with generative models for open domain question answering. In *Proceedings of EACL*, pages 874–880, 2021.
410. Kenton Lee, Ming-Wei Chang, and Kristina Toutanova. Latent retrieval for weakly supervised open domain question answering. In *Proceedings of the 57th Annual Meeting of the Association for Computational Linguistics*, pages 6086–6096, Stroudsburg, PA, USA, 2019. ACL.
411. Minjoon Seo, Jinhyuk Lee, Tom Kwiatkowski, Ankur Parikh, Ali Farhadi, and Hannaneh Hajishirzi. Real-time open-domain question answering with dense-sparse phrase index. In *Proceedings of ACL*, pages 4430–4441, 2019.
412. Kelvin Guu, Kenton Lee, Zora Tung, Panupong Pasupat, and Ming-Wei Chang. Realm: Retrieval-augmented language model pre-training. *arXiv preprint arXiv:2002.08909*, 2020.

413. Chen Zhao, Chenyan Xiong, Jordan Boyd-Graber, and Hal Daumé III. Distantly-supervised evidence retrieval enables question answering without evidence annotation. *arXiv preprint arXiv:2110.04889*, 2021.
414. Gautier Izacard and Edouard Grave. Distilling knowledge from reader to retriever for question answering. *arXiv preprint arXiv:2012.04584*, 2020.
415. David D McDonald. Natural language generation. Technical report, MASSACHUSETTS UNIV AMHERST DEPT OF COMPUTER AND INFORMATION SCIENCE, 1986.
416. Ehud Reiter, Chris Mellish, and John Levine. Automatic generation of technical documentation. *Applied Artificial Intelligence an International Journal*, 9(3):259–287, 1995.
417. Michael A Covington. Building natural language generation systems. *Language*, 77(3):611–612, 2001.
418. Dzmitry Bahdanau, Kyunghyun Cho, and Yoshua Bengio. Neural machine translation by jointly learning to align and translate. In *ICLR*, 2015.
419. Minh-Thang Luong, Hieu Pham, and Christopher D Manning. Effective approaches to attention-based neural machine translation. *arXiv preprint arXiv:1508.04025*, 2015.
420. Alexander M Rush, Sumit Chopra, and Jason Weston. A neural attention model for abstractive sentence summarization. In *Proceedings of the 2015 Conference on Empirical Methods in Natural Language Processing*, pages 379–389, 2015.
421. Ramesh Nallapati, Bowen Zhou, Cicero dos Santos, Çağlar Gulçehre, and Bing Xiang. Abstractive text summarization using sequence-to-sequence rnns and beyond. In *Proceedings of The 20th SIGNLL Conference on Computational Natural Language Learning*, pages 280–290, 2016.
422. Sumit Chopra, Michael Auli, and Alexander M Rush. Abstractive sentence summarization with attentive recurrent neural networks. In *Proceedings of the 2016 Conference of the North American Chapter of the Association for Computational Linguistics: Human Language Technologies*, pages 93–98, 2016.
423. Oriol Vinyals and Quoc Le. A neural conversational model. *arXiv e-prints*, pages arXiv–1506, 2015.
424. Jiwei Li, Michel Galley, Chris Brockett, Jianfeng Gao, and William B Dolan. A diversity-promoting objective function for neural conversation models. In *Proceedings of the 2016 Conference of the North American Chapter of the Association for Computational Linguistics: Human Language Technologies*, pages 110–119, 2016.
425. Iulian Serban, Alessandro Sordani, Yoshua Bengio, Aaron Courville, and Joelle Pineau. Building end-to-end dialogue systems using generative hierarchical neural network models. In *Proceedings of the AAAI Conference on Artificial Intelligence*, volume 30, 2016.
426. Zhilin Yang, Ye Yuan, Yuxin Wu, William W Cohen, and Russ R Salakhutdinov. Review networks for caption generation. *Advances in neural information processing systems*, 29:2361–2369, 2016.
427. Peter Anderson, Xiaodong He, Chris Buehler, Damien Teney, Mark Johnson, Stephen Gould, and Lei Zhang. Bottom-up and top-down attention for image captioning and visual question answering. In *Proceedings of the IEEE conference on computer vision and pattern recognition*, pages 6077–6086, 2018.
428. Yizhe Zhang, Siqi Sun, Michel Galley, Yen-Chun Chen, Chris Brockett, Xiang Gao, Jianfeng Gao, Jingjing Liu, and Bill Dolan. Dialogpt: Large-scale generative pre-training for conversational response generation. *arXiv preprint arXiv:1911.00536*, 2019.
429. Daniel Adiwardana, Minh-Thang Luong, David R So, Jamie Hall, Noah Fiedel, Romal Thoppilan, Zi Yang, Apoorv Kulshreshtha, Gaurav Nemade, Yifeng Lu, et al. Towards a human-like open-domain chatbot. *arXiv preprint arXiv:2001.09977*, 2020.
430. Stephen Roller, Emily Dinan, Naman Goyal, Da Ju, Mary Williamson, Yinhan Liu, Jing Xu, Myle Ott, Kurt Shuster, Eric M Smith, et al. Recipes for building an open-domain chatbot. *arXiv preprint arXiv:2004.13637*, 2020.
431. Siqi Bao, Huang He, Fan Wang, Hua Wu, and Haifeng Wang. Plato: Pre-trained dialogue generation model with discrete latent variable. *arXiv preprint arXiv:1910.07931*, 2019.
432. Siqi Bao, Huang He, Fan Wang, Hua Wu, Haifeng Wang, Wenquan Wu, Zhen Guo, Zhibin Liu, and Xinchao Xu. Plato-2: Towards building an open-domain chatbot via curriculum learning. *arXiv preprint arXiv:2006.16779*, 2020.
433. Siqi Bao, Huang He, Fan Wang, Hua Wu, Haifeng Wang, Wenquan Wu, Zhihua Wu, Zhen Guo, Hua Lu, Xinxian Huang, et al. Plato-xl: Exploring the large-scale pre-training of dialogue generation. *arXiv preprint arXiv:2109.09519*, 2021.
434. Hao Zhou, Pei Ke, Zheng Zhang, Yuxian Gu, Yinhe Zheng, Chujie Zheng, Yida Wang, Chen Henry Wu, Hao Sun, Xiaocong Yang, et al. Eva: An open-domain chinese dialogue system with large-scale generative pre-training. *arXiv preprint arXiv:2108.01547*, 2021.
435. Dana Rubinstein, Effi Levi, Roy Schwartz, and Ari Rappoport. How well do distributional models capture different types of semantic knowledge? In *Proceedings of ACL*, pages 726–730, 2015.
436. Abhijeet Gupta, Gemma Boleda, Marco Baroni, and Sebastian Padó. Distributional vectors encode referential attributes. In *Proceedings of EMNLP*, pages 12–21, 2015.
437. Nelson F. Liu, Matt Gardner, Yonatan Belinkov, Matthew E. Peters, and Noah A. Smith. Linguistic knowledge and transferability of contextual representations. In *Proceedings of NAACL-HLT*, pages 1073–1094, 2019.
438. Ian Tenney, Patrick Xia, Berlin Chen, Alex Wang, Adam Poliak, R Thomas McCoy, Najoung Kim, Benjamin Van Durme, Sam Bowman, Dipanjan Das, and Ellie Pavlick. What do you learn from context? probing for sentence structure in contextualized word representations. In *Proceedings of ICLR*, 2019.
439. David Vilares, Michalina Strzyz, Anders Søgaard, and Carlos Gómez-Rodríguez. Parsing as pretraining. In *Proceedings of AAAI*, pages 9114–9121, 2020.
440. John Hewitt and Christopher D. Manning. A structural probe for finding syntax in word representations. In *Proceedings of NAACL-HLT*, pages 4129–4138, 2019.



441. Ganesh Jawahar, Benoît Sagot, and Djamé Seddah. What does BERT learn about the structure of language? In *Proceedings of ACL*, pages 3651–3657, 2019.
442. Alessio Miaschi and Felice Dell’Orletta. Contextual and non-contextual word embeddings: an in-depth linguistic investigation. In *Proceedings of RepL4NLP*, pages 110–119, 2020.
443. Christopher D Manning, Kevin Clark, John Hewitt, Urvashi Khandelwal, and Omer Levy. Emergent linguistic structure in artificial neural networks trained by self-supervision. *PNAS*, 117(48):30046–30054, 2020.
444. Taeuk Kim, Jihun Choi, Daniel Edmiston, and Sang-goo Lee. Are pre-trained language models aware of phrases? simple but strong baselines for grammar induction. In *Proceedings of ICLR*, 2020.
445. Kevin Clark, Urvashi Khandelwal, Omer Levy, and Christopher D Manning. What does bert look at? an analysis of bert’s attention. In *Proceedings of BlackboxNLP*, pages 276–286, 2019.
446. Yongjie Lin, Yi Chern Tan, and Robert Frank. Open sesame: Getting inside bert’s linguistic knowledge. In *Proceedings of BlackboxNLP*, pages 241–253, 2019.
447. Phu Mon Htut, Jason Phang, Shikha Bordia, and Samuel R Bowman. Do attention heads in bert track syntactic dependencies? *arXiv preprint arXiv:1911.12246*, 2019.
448. Yoav Goldberg. Assessing bert’s syntactic abilities. *arXiv preprint arXiv:1901.05287*, 2019.
449. Zhiyong Wu, Yun Chen, Ben Kao, and Qun Liu. Perturbed masking: Parameter-free probing for analyzing and interpreting BERT. In *Proceedings of ACL*, pages 4166–4176, 2020.
450. Marten Van Schijndel, Aaron Mueller, and Tal Linzen. Quantity doesn’t buy quality syntax with neural language models. In *Proceedings of EMNLP-IJCNLP*, pages 5830–5836, 2019.
451. Xuhui Zhou, Yue Zhang, Leyang Cui, and Dand an Huang. Evaluating commonsense in pre-trained language models. In *Proceedings of AAAI*, pages 9733–9740, 2020.
452. Zied Bouraoui, José Camacho-Collados, and Steven Schockaert. Inducing relational knowledge from BERT. In *Proceedings of AAAI*, pages 7456–7463, 2020.
453. Zhengbao Jiang, Frank F Xu, Jun Araki, and Graham Neubig. How can we know what language models know? *Transactions of the Association for Computational Linguistics*, 8:423–438, 2020.
454. Allyson Ettinger. What BERT is not: Lessons from a new suite of psycholinguistic diagnostics for language models. *TACL*, 8:34–48, 2020.
455. Joe Davison, Joshua Feldman, and Alexander M. Rush. Commonsense knowledge mining from pretrained models. In *EMNLP-IJCNLP*, pages 1173–1178, 2019.
456. Jeff Da and Jungo Kasai. Cracking the contextual commonsense code: Understanding commonsense reasoning aptitude of deep contextual representations. In *Proceedings of EMNLP Workshop*, 2019.
457. Maxwell Forbes, Ari Holtzman, and Yejin Choi. Do neural language representations learn physical commonsense? In *Proceedings of the 41th Annual Meeting of the Cognitive Science Society, CogSci 2019: Creativity + Cognition + Computation, Montreal, Canada, July 24-27, 2019*, pages 1753–1759, 2019.
458. Nina Pörner, Ulli Waltinger, and Hinrich Schütze. E-BERT: efficient-yet-effective entity embeddings for BERT. In *Proceedings of EMNLP*, pages 803–818, 2020.
459. Eric Wallace, Yizhong Wang, Sujian Li, Sameer Singh, and Matt Gardner. Do NLP models know numbers? probing numeracy in embeddings. In *Proceedings of EMNLP-IJCNLP*, pages 5306–5314, 2019.
460. Xuanli He, Lingjuan Lyu, Lichao Sun, and Qionghai Xu. Model extraction and adversarial transferability, your bert is vulnerable! In *Proceedings of NAACL-HLT*, pages 2006–2012, 2021.
461. Di Jin, Zhijing Jin, Joey Tianyi Zhou, and Peter Szolovits. Is bert really robust? a strong baseline for natural language attack on text classification and entailment. In *Proceedings of the AAAI conference on artificial intelligence*, volume 34, pages 8018–8025, 2020.
462. Yuan Zang, Fanchao Qi, Chenghao Yang, Zhiyuan Liu, Meng Zhang, Qun Liu, and Maosong Sun. Word-level textual adversarial attacking as combinatorial optimization. In *Proceedings of ACL*, pages 6066–6080, 2020.
463. Linyang Li, Ruotian Ma, Qipeng Guo, Xiangyang Xue, and Xipeng Qiu. Bert-attack: Adversarial attack against bert using bert. In *Proceedings of EMNLP*, pages 6193–6202, 2020.
464. Siddhant Garg and Goutham Ramakrishnan. Bae: Bert-based adversarial examples for text classification. In *Proceedings of EMNLP*, pages 6174–6181, 2020.
465. Dong Wang, Ning Ding, Piji Li, and Hai-Tao Zheng. Cline: Contrastive learning with semantic negative examples for natural language understanding. In *Proceedings of ACL*, 2021.
466. Eric Wallace, Pedro Rodriguez, Shi Feng, Ikuya Yamada, and Jordan Boyd-Graber. Trick me if you can: Human-in-the-loop generation of adversarial examples for question answering. *TACL*, 7:387–401, 2019.
467. Yixin Nie, Adina Williams, Emily Dinan, Mohit Bansal, Jason Weston, and Douwe Kiela. Adversarial NLI: A new benchmark for natural language understanding. In *Proceedings of ACL*, pages 4885–4901, 2020.
468. Timothy Niven and Hung-Yu Kao. Probing neural network comprehension of natural language arguments. In *Proceedings of ACL*, pages 4658–4664, 2019.
469. Eric Wallace, Shi Feng, Nikhil Kand pal, Matt Gardner, and Sameer Singh. Universal adversarial triggers for attacking and analyzing nlp. In *Proceedings of EMNLP-IJCNLP*, pages 2153–2162, 2019.
470. Xiaoyi Chen, Ahmed Salem, Michael Backes, Shiqing Ma, and Yang Zhang. Badnl: Backdoor attacks against nlp models. In *ICML 2021 Workshop on Adversarial Machine Learning*, 2021.
471. Wenkai Yang, Lei Li, Zhiyuan Zhang, Xuancheng Ren, Xu Sun, and Bin He. Be careful about poisoned word embeddings: Exploring the vulnerability of the embedding layers in NLP models. In *Proceedings of NAACL-HLT*, 2021.

472. Siddhant Garg, Adarsh Kumar, Vibhor Goel, and Yingyu Liang. Can adversarial weight perturbations inject neural backdoors. In *Proceedings of the 29th ACM International Conference on Information & Knowledge Management*, pages 2029–2032, 2020.
473. Keita Kurita, Paul Michel, and Graham Neubig. Weight poisoning attacks on pre-trained models. *arXiv preprint arXiv:2004.06660*, 2020.
474. Zhengyan Zhang, Guangxuan Xiao, Yongwei Li, Tian Lv, Fanchao Qi, Yasheng Wang, Xin Jiang, Zhiyuan Liu, and Maosong Sun. Red alarm for pre-trained models: Universal vulnerabilities by neuron-level backdoor attacks. *arXiv preprint arXiv:2101.06969*, 2021.
475. Wenkai Yang, Yankai Lin, Peng Li, Jie Zhou, and Xu Sun. Rethinking stealthiness of backdoor attack against nlp models. In *Proceedings of ACL*, pages 5543–5557, 2021.
476. Paul Michel, Omer Levy, and Graham Neubig. Are sixteen heads really better than one? In *Proceedings of NeurIPS*, pages 14014–14024, 2019.
477. Joris Baan, Maartje ter Hoeve, Marlies van der Wees, Anne Schuth, and Maarten de Rijke. Understanding multi-head attention in abstractive summarization. *arXiv preprint arXiv:1911.03898*, 2019.
478. Olga Kovaleva, Alexey Romanov, Anna Rogers, and Anna Rumshisky. Revealing the dark secrets of BERT. In *Proceedings of EMNLP-IJCNLP*, pages 4364–4373, 2019.
479. Zhengyan Zhang, Yankai Lin, Zhiyuan Liu, Peng Li, Maosong Sun, and Jie Zhou. Moefication: Conditional computation of transformer models for efficient inference. *arXiv preprint arXiv:2110.01786*, 2021.
480. Mitchell A. Gordon, Kevin Duh, and Nicholas Andrews. Compressing BERT: studying the effects of weight pruning on transfer learning. In *Proceedings of RepL4NLP*, pages 143–155, 2020.
481. Sai Prasanna, Anna Rogers, and Anna Rumshisky. When BERT plays the lottery, all tickets are winning. In *Proceedings of EMNLP*, pages 3208–3229, 2020.
482. Nikunj Saunshi, Orestis Plevrakis, Sanjeev Arora, Mikhail Khodak, and Hrishikesh Khandeparkar. A theoretical analysis of contrastive unsupervised representation learning. In *ICML*, 2019.
483. Luyang Huang, Shuyang Cao, Nikolaus Parulian, Heng Ji, and Lu Wang. Efficient attentions for long document summarization. In *Proceedings of the 2021 Conference of the North American Chapter of the Association for Computational Linguistics: Human Language Technologies*, pages 1419–1436, 2021.
484. Zichao Yang, Diyi Yang, Chris Dyer, Xiaodong He, Alex Smola, and Eduard Hovy. Hierarchical attention networks for document classification. In *Proceedings of the 2016 conference of the North American chapter of the association for computational linguistics: human language technologies*, pages 1480–1489, 2016.
485. Ashutosh Adhikari, Achyudh Ram, Raphael Tang, and Jimmy Lin. Docbert: Bert for document classification. *arXiv preprint arXiv:1904.08398*, 2019.
486. Yuan Yao, Deming Ye, Peng Li, Xu Han, Yankai Lin, Zhenghao Liu, Zhiyuan Liu, Lixin Huang, Jie Zhou, and Maosong Sun. Docred: A large-scale document-level relation extraction dataset. In *Proceedings of the 57th Annual Meeting of the Association for Computational Linguistics*, pages 764–777, 2019.
487. Sarthak Jain, Madeleine van Zuylen, Hannaneh Hajishirzi, and Iz Beltagy. Scirex: A challenge dataset for document-level information extraction. In *Proceedings of the 58th Annual Meeting of the Association for Computational Linguistics*, pages 7506–7516, 2020.
488. Zhilin Yang, Peng Qi, Saizheng Zhang, Yoshua Bengio, William Cohen, Ruslan Salakhutdinov, and Christopher D Manning. Hotpotqa: A dataset for diverse, explainable multi-hop question answering. In *Proceedings of the 2018 Conference on Empirical Methods in Natural Language Processing*, pages 2369–2380, 2018.
489. Johannes Welbl, Pontus Stenetorp, and Sebastian Riedel. Constructing datasets for multi-hop reading comprehension across documents. *Transactions of the Association for Computational Linguistics*, 6:287–302, 2018.
490. Kyle Lo, Lucy Lu Wang, Mark Neumann, Rodney Kinney, and Daniel S Weld. S2orc: The semantic scholar open research corpus. In *Proceedings of the 58th Annual Meeting of the Association for Computational Linguistics*, pages 4969–4983, 2020.
491. Haoxi Zhong, Chaojun Xiao, Cunchao Tu, Tianyang Zhang, Zhiyuan Liu, and Maosong Sun. How does nlp benefit legal system: A summary of legal artificial intelligence. In *Proceedings of the 58th Annual Meeting of the Association for Computational Linguistics*, pages 5218–5230, 2020.
492. Lesly Miculicich Werlen, Dhananjay Ram, Nikolaos Pappas, and James Henderson. Document-level neural machine translation with hierarchical attention networks. In *Proceedings of the 2018 Conference on Empirical Methods in Natural Language Processing*, pages 2947–2954, 2018.
493. Yang Liu and Mirella Lapata. Hierarchical transformers for multi-document summarization. In *Proceedings of the 57th Annual Meeting of the Association for Computational Linguistics*, pages 5070–5081, 2019.
494. Zihao Ye, Qipeng Guo, Quan Gan, Xipeng Qiu, and Zheng Zhang. Bp-transformer: Modelling long-range context via binary partitioning. *arXiv preprint arXiv:1911.04070*, 2019.
495. Chuhan Wu, Fangzhao Wu, Tao Qi, and Yongfeng Huang. Hi-transformer: Hierarchical interactive transformer for efficient and effective long document modeling. *arXiv preprint arXiv:2106.01040*, 2021.
496. Rewon Child, Scott Gray, Alec Radford, and Ilya Sutskever. Generating long sequences with sparse transformers. *arXiv preprint arXiv:1904.10509*, 2019.
497. Jiezhong Qiu, Hao Ma, Omer Levy, Wen-tau Yih, Sinong Wang, and Jie Tang. Blockwise self-attention for long document understanding. In *Proceedings of the 2020 Conference on Empirical Methods in Natural Language Processing: Findings*, pages 2555–2565, 2020.

498. Iz Beltagy, Matthew E Peters, and Arman Cohan. Longformer: The long-document transformer. *arXiv preprint arXiv:2004.05150*, 2020.
499. Manzil Zaheer, Guru Guruganesh, Kumar Avinava Dubey, Joshua Ainslie, Chris Alberti, Santiago Ontanon, Philip Pham, Anirudh Ravula, Qifan Wang, Li Yang, et al. Big bird: Transformers for longer sequences. In *NeurIPS*, 2020.
500. Aurko Roy, Mohammad Saffar, Ashish Vaswani, and David Grangier. Efficient content-based sparse attention with routing transformers. *Transactions of the Association for Computational Linguistics*, 9:53–68, 2021.
501. Sinong Wang, Belinda Z Li, Madian Khabsa, Han Fang, and Hao Ma. Linformer: Self-attention with linear complexity. *arXiv preprint arXiv:2006.04768*, 2020.
502. Angelos Katharopoulos, Apoorv Vyas, Nikolaos Pappas, and François Fleuret. Transformers are rnns: Fast autoregressive transformers with linear attention. In *International Conference on Machine Learning*, pages 5156–5165. PMLR, 2020.
503. Krzysztof Choromanski, Valerii Likhoshesterov, David Dohan, Xingyou Song, Andreea Gane, Tamas Sarlos, Peter Hawkins, Jared Davis, David Belanger, Lucy Colwell, et al. Masked language modeling for proteins via linearly scalable long-context transformers. *arXiv preprint arXiv:2006.03555*, 2020.
504. Saurabh Goyal, Anamitra Roy Choudhury, Saurabh Raje, Venkatesan Chakaravarthy, Yogish Sabharwal, and Ashish Verma. Power-bert: Accelerating bert inference via progressive word-vector elimination. In *International Conference on Machine Learning*, pages 3690–3699. PMLR, 2020.
505. Gyuwan Kim and Kyunghyun Cho. Length-adaptive transformer: Train once with length drop, use anytime with search. *arXiv preprint arXiv:2010.07003*, 2020.
506. Deming Ye, Yankai Lin, Yufei Huang, and Maosong Sun. Tr-bert: Dynamic token reduction for accelerating bert inference. In *Proceedings of the 2021 Conference of the North American Chapter of the Association for Computational Linguistics: Human Language Technologies*, pages 5798–5809, 2021.
507. Jack W Rae, Anna Potapenko, Siddhant M Jayakumar, Chloe Hillier, and Timothy P Lillicrap. Compressive transformers for long-range sequence modelling. In *International Conference on Learning Representations*, 2019.
508. Qingyang Wu, Zhenzhong Lan, Jing Gu, and Zhou Yu. Memformer: The memory-augmented transformer. *arXiv preprint arXiv:2010.06891*, 2020.
509. Zhu Zhang, Chang Zhou, Jianxin Ma, Zhijie Lin, Jingren Zhou, Hongxia Yang, and Zhou Zhao. Learning to rehearse in long sequence memorization. *arXiv preprint arXiv:2106.01096*, 2021.
510. Ming Ding, Chang Zhou, Hongxia Yang, and Jie Tang. Coglitx: Applying bert to long texts. *Advances in Neural Information Processing Systems*, 33:12792–12804, 2020.
511. Minghan Li and Eric Gaussier. Keybl: Selecting key blocks with local pre-ranking for long document information retrieval. In *Proceedings of the 44th International ACM SIGIR Conference on Research and Development in Information Retrieval*, pages 2207–2211, 2021.
512. Haejun Lee, Drew A Hudson, Kangwook Lee, and Christopher D Manning. Slm: Learning a discourse language representation with sentence unshuffling. In *Proceedings of the 2020 Conference on Empirical Methods in Natural Language Processing (EMNLP)*, pages 1551–1562, 2020.
513. Siyu Ding, Junyuan Shang, Shuohuan Wang, Yu Sun, Hao Tian, Hua Wu, and Haifeng Wang. Ernie-doc: The retrospective long-document modeling transformer. *arXiv preprint arXiv:2012.15688*, 2020.
514. Rich Caruana. Multitask learning. *Machine learning*, 28(1):41–75, 1997.
515. Sebastian Ruder. An overview of multi-task learning in deep neural networks. *arXiv preprint arXiv:1706.05098*, 2017.
516. Kazuma Hashimoto, Caiming Xiong, Yoshimasa Tsuruoka, and Richard Socher. A joint many-task model: Growing a neural network for multiple nlp tasks. *arXiv preprint arXiv:1611.01587*, 2016.
517. Naveen Arivazhagan, Ankur Bapna, Orhan Firat, Dmitry Lepikhin, Melvin Johnson, Maxim Krikun, Mia Xu Chen, Yuan Cao, George Foster, Colin Cherry, et al. Massively multilingual neural machine translation in the wild: Findings and challenges. *arXiv preprint arXiv:1907.05019*, 2019.
518. Xiaodong Liu, Pengcheng He, Weizhu Chen, and Jianfeng Gao. Multi-task deep neural networks for natural language understanding. *arXiv preprint arXiv:1901.11504*, 2019.
519. Yi Tay, Zhe Zhao, Dara Bahri, Donald Metzler, and Da-Cheng Juan. Hypergrid transformers: Towards a single model for multiple tasks. In *International Conference on Learning Representations*, 2020.
520. Rabeeh Karimi Mahabadi, Sebastian Ruder, Mostafa Dehghani, and James Henderson. Parameter-efficient multi-task fine-tuning for transformers via shared hypernetworks. *arXiv preprint arXiv:2106.04489*, 2021.
521. Asa Cooper Stickland and Iain Murray. Bert and pals: Projected attention layers for efficient adaptation in multi-task learning. In *International Conference on Machine Learning*, pages 5986–5995. PMLR, 2019.
522. Kevin Clark, Minh-Thang Luong, Urvashi Khandelwal, Christopher D Manning, and Quoc V Le. Bam! born-again multi-task networks for natural language understanding. *arXiv preprint arXiv:1907.04829*, 2019.
523. Alex Wang, Jan Hula, Patrick Xia, Raghavendra Pappagari, R Thomas McCoy, Roma Patel, Najoung Kim, Ian Tenney, Yinghui Huang, Katherin Yu, et al. Can you tell me how to get past sesame street? sentence-level pretraining beyond language modeling. *arXiv preprint arXiv:1812.10860*, 2018.
524. Qingkai Zeng, Wenhao Yu, Mengxia Yu, Tianwen Jiang, Tim Weninger, and Meng Jiang. Tri-train: Automatic pre-fine tuning between pre-training and fine-tuning for sciner. In *Proceedings of the 2020 Conference on Empirical Methods in Natural Language Processing: Findings*, pages 4778–4787, 2020.
525. Jason Phang, Thibault Févry, and Samuel R Bowman. Sentence encoders on stilts: Supplementary training on intermediate labeled-data tasks. *arXiv preprint arXiv:1811.01088*, 2018.

526. Michael Glass, Alfio Gliozzo, Rishav Chakravarti, Anthony Ferritto, Lin Pan, GP Bhargav, Dinesh Garg, and Avirup Sil. Span selection pre-training for question answering. *arXiv preprint arXiv:1909.04120*, 2019.
527. Yujia Qin, Yankai Lin, Jing Yi, Jiajie Zhang, Xu Han, Zhengyan Zhang, Yusheng Su, Zhiyuan Liu, Peng Li, Maosong Sun, et al. Knowledge inheritance for pre-trained language models. *arXiv preprint arXiv:2105.13880*, 2021.
528. Jinhyuk Lee, Wonjin Yoon, Sungdong Kim, Donghyeon Kim, Sunkyu Kim, Chan Ho So, and Jaewoo Kang. Biobert: a pre-trained biomedical language representation model for biomedical text mining. *Bioinformatics*, 36(4):1234–1240, 2020.
529. Armen Aghajanyan, Ankit Gupta, Akshat Shrivastava, Xilun Chen, Luke Zettlemoyer, and Sonal Gupta. Muppet: Massive multi-task representations with pre-finetuning. *arXiv preprint arXiv:2101.11038*, 2021.
530. Yada Pruksachatkun, Jason Phang, Haokun Liu, Phu Mon Htut, Xiaoyi Zhang, Richard Yuanzhe Pang, Clara Vania, Katharina Kann, and Samuel R Bowman. Intermediate-task transfer learning with pretrained models for natural language understanding: When and why does it work? *arXiv preprint arXiv:2005.00628*, 2020.
531. Alon Talmor and Jonathan Berant. Multiqa: An empirical investigation of generalization and transfer in reading comprehension. *arXiv preprint arXiv:1905.13453*, 2019.
532. Yu-Hsiang Lin, Chian-Yu Chen, Jean Lee, Zirui Li, Yuyan Zhang, Mengzhou Xia, Shruti Rijhwani, Junxian He, Zhisong Zhang, Xuezhe Ma, et al. Choosing transfer languages for cross-lingual learning. *arXiv preprint arXiv:1905.12688*, 2019.
533. Tu Vu, Tong Wang, Tsendsuren Munkhdalai, Alessandro Sordani, Adam Trischler, Andrew Mattarella-Micke, Subhransu Maji, and Mohit Iyyer. Exploring and predicting transferability across nlp tasks. *arXiv preprint arXiv:2005.00770*, 2020.
534. Yusheng Su, Xiaozhi Wang, Yujia Qin, Chi-Min Chan, Yankai Lin, Zhiyuan Liu, Peng Li, Juanzi Li, Lei Hou, Maosong Sun, et al. On transferability of prompt tuning for natural language understanding. *arXiv preprint arXiv:2111.06719*, 2021.
535. Clifton Poth, Jonas Pfeiffer, Andreas Rücklé, and Iryna Gurevych. What to pre-train on? efficient intermediate task selection. *arXiv preprint arXiv:2104.08247*, 2021.
536. Christopher Fifty, Ehsan Amid, Zhe Zhao, Tianhe Yu, Rohan Anil, and Chelsea Finn. Efficiently identifying task groupings for multi-task learning. In *Thirty-Fifth Conference on Neural Information Processing Systems*, 2021.
537. Han Guo, Ramakanth Pasunuru, and Mohit Bansal. Autosem: Automatic task selection and mixing in multi-task learning. *arXiv preprint arXiv:1904.04153*, 2019.
538. Jason Wei, Maarten Bosma, Vincent Y Zhao, Kelvin Guu, Adams Wei Yu, Brian Lester, Nan Du, Andrew M Dai, and Quoc V Le. Finetuned language models are zero-shot learners. *arXiv preprint arXiv:2109.01652*, 2021.
539. Daniel Khashabi, Sewon Min, Tushar Khot, Ashish Sabharwal, Oyvind Tafjord, Peter Clark, and Hannaneh Hajishirzi. Unifiedqa: Crossing format boundaries with a single qa system. *arXiv preprint arXiv:2005.00700*, 2020.
540. Bryan McCann, Nitish Shirish Keskar, Caiming Xiong, and Richard Socher. The natural language decathlon: Multitask learning as question answering. *arXiv preprint arXiv:1806.08730*, 2018.
541. Wenpeng Yin, Nazneen Fatema Rajani, Dragomir Radev, Richard Socher, and Caiming Xiong. Universal natural language processing with limited annotations: Try few-shot textual entailment as a start. *arXiv preprint arXiv:2010.02584*, 2020.
542. Sebastian Thrun and Lorien Pratt. *Learning to learn*. Springer Science & Business Media, 2012.
543. Alan D Baddeley. *Human memory: Theory and practice*. psychology press, 1997.
544. Michael McCloskey and Neal J Cohen. Catastrophic interference in connectionist networks: The sequential learning problem. In *Psychology of learning and motivation*, volume 24, pages 109–165. Elsevier, 1989.
545. James Kirkpatrick, Razvan Pascanu, Neil Rabinowitz, Joel Veness, Guillaume Desjardins, Andrei A Rusu, Kieran Milan, John Quan, Tiago Ramalho, Agnieszka Grabska-Barwinska, et al. Overcoming catastrophic forgetting in neural networks. *Proceedings of NAS*, pages 3521–3526, 2017.
546. Friedemann Zenke, Ben Poole, and Surya Ganguli. Continual learning through synaptic intelligence. In *Proceedings of ICML*, pages 3987–3995, 2017.
547. Zhizhong Li and Derek Hoiem. Learning without forgetting. *TPAMI*, 40(12):2935–2947, 2017.
548. Xialei Liu, Marc Masana, Luis Herranz, Joost Van de Weijer, Antonio M Lopez, and Andrew D Bagdanov. Rotate your networks: Better weight consolidation and less catastrophic forgetting. In *Proceedings of ICPR*, pages 2262–2268, 2018.
549. Hippolyt Ritter, Aleksandar Botev, and David Barber. Online structured laplace approximations for overcoming catastrophic forgetting. In *Proceedings of NIPS*, pages 3738–3748, 2018.
550. David Lopez-Paz and Marc’Aurelio Ranzato. Gradient episodic memory for continual learning. In *Proceedings of NIPS*, pages 6467–6476, 2017.
551. Sylvestre-Alvise Rebuffi, Alexander Kolesnikov, Georg Sperl, and Christoph H Lampert. iCaRL: Incremental classifier and representation learning. In *Proceedings of CVPR*, pages 2001–2010, 2017.
552. Hanul Shin, Jung Kwon Lee, Jaehong Kim, and Jiwon Kim. Continual learning with deep generative replay. In *Proceedings of NIPS*, pages 2990–2999, 2017.
553. Ronald Kemker and Christopher Kanan. Fearnnet: Brain-inspired model for incremental learning. In *Proceedings of ICLR*, 2018.
554. Rahaf Aljundi, Francesca Babiloni, Mohamed Elhoseiny, Marcus Rohrbach, and Tinne Tuytelaars. Memory aware synapses: Learning what (not) to forget. In *Proceedings of ECCV*, pages 139–154, 2018.
555. Arslan Chaudhry, Marc’Aurelio Ranzato, Marcus Rohrbach, and Mohamed Elhoseiny. Efficient lifelong learning with a-gem. In *Proceedings of ICLR*, 2019.
556. Fan-Keng Sun, Cheng-Hao Ho, and Hung-Yi Lee. Lamol: Language modeling for lifelong language learning. In *International Conference on Learning Representations*, 2019.

557. Sanyuan Chen, Yutai Hou, Yiming Cui, Wanxiang Che, Ting Liu, and Xiangzhan Yu. Recall and learn: Fine-tuning deep pretrained language models with less forgetting. In *Proceedings of EMNLP*, pages 7870–7881, 2020.
558. Hong Wang, Wenhan Xiong, Mo Yu, Xiaoxiao Guo, Shiyu Chang, and William Yang Wang. Sentence embedding alignment for lifelong relation extraction. In *Proceedings of the 2019 Conference of the North American Chapter of the Association for Computational Linguistics: Human Language Technologies, Volume 1 (Long and Short Papers)*, pages 796–806, 2019.
559. Xu Han, Yi Dai, Tianyu Gao, Yankai Lin, Zhiyuan Liu, Peng Li, Maosong Sun, and Jie Zhou. Continual relation learning via episodic memory activation and reconsolidation. In *Proceedings of the 58th Annual Meeting of the Association for Computational Linguistics*, pages 6429–6440, 2020.
560. Cyprien de Masson d’Autume, Sebastian Ruder, Lingpeng Kong, and Dani Yogatama. Episodic memory in lifelong language learning. *Advances in Neural Information Processing Systems*, 32:13143–13152, 2019.
561. Abiola Obamuyide, Andreas Vlachos, et al. Meta-learning improves lifelong relation extraction. 2019.
562. Tongtong Wu, Xuekai Li, Yuan-Fang Li, Reza Haffari, Guilin Qi, Yujin Zhu, and Guoqiang Xu. Curriculum-meta learning for order-robust continual relation extraction. *CoRR*, abs/2101.01926, 2021.
563. Hangjie Shen, Shenggen Ju, Jieping Sun, Run Chen, and Yuezhong Liu. Efficient lifelong relation extraction with dynamic regularization. In *CCF International Conference on Natural Language Processing and Chinese Computing*, pages 181–192. Springer, 2020.
564. Li Cui, Deqing Yang, Jiaxin Yu, Chengwei Hu, Jiayang Cheng, Jingjie Yi, and Yanghua Xiao. Refining sample embeddings with relation prototypes to enhance continual relation extraction. In *Proceedings of the 59th Annual Meeting of the Association for Computational Linguistics and the 11th International Joint Conference on Natural Language Processing (Volume 1: Long Papers)*, pages 232–243, 2021.
565. Prashanth Vijayaraghavan and Deb Roy. Lifelong knowledge-enriched social event representation learning. In *Proceedings of the 16th Conference of the European Chapter of the Association for Computational Linguistics: Main Volume*, pages 3624–3635, 2021.
566. Tianqi Chen, Ian Goodfellow, and Jonathon Shlens. Net2Net: Accelerating learning via knowledge transfer. In *Proceedings of ICLR*, 2016.
567. Andrei A Rusu, Neil C Rabinowitz, Guillaume Desjardins, Hubert Soyer, James Kirkpatrick, Koray Kavukcuoglu, Razvan Pascanu, and Raia Hadsell. Progressive neural networks. *ai.google*, 2016.
568. Chrisantha Fernando, Dylan Banarse, Charles Blundell, Yori Zwols, David Ha, Andrei A Rusu, Alexander Pritzel, and Daan Wierstra. PathNet: Evolution channels gradient descent in super neural networks. *ai.google*, 2017.
569. Zhuohan Li, Eric Wallace, Sheng Shen, Kevin Lin, Kurt Keutzer, Dan Klein, and Joseph E Gonzalez. Train large, then compress: Rethinking model size for efficient training and inference of transformers. *arXiv preprint arXiv:2002.11794*, 2020.
570. Xiaotao Gu, Liyuan Liu, Hongkun Yu, Jing Li, Chen Chen, and Jiawei Han. On the transformer growth for progressive bert training. In *Proceedings of the 2021 Conference of the North American Chapter of the Association for Computational Linguistics: Human Language Technologies*, pages 5174–5180, 2021.
571. Tu Vu, Brian Lester, Noah Constant, Rami Al-Rfou, and Daniel Cer. Spot: Better frozen model adaptation through soft prompt transfer. *arXiv preprint arXiv:2110.07904*, 2021.
572. Chengwei Qin and Shafiq Joty. Lfpt5: A unified framework for lifelong few-shot language learning based on prompt tuning of t5. *arXiv preprint arXiv:2110.07298*, 2021.
573. Houyu Zhang, Zhenghao Liu, Chenyan Xiong, and Zhiyuan Liu. Grounded conversation generation as guided traverses in commonsense knowledge graphs. In *Proceedings of the 58th Annual Meeting of the Association for Computational Linguistics*, pages 2031–2043, 2020.
574. An Yang, Quan Wang, Jing Liu, Kai Liu, Yajuan Lyu, Hua Wu, Qiaoqiao She, and Sujian Li. Enhancing pre-trained language representations with rich knowledge for machine reading comprehension. In *Proceedings of the 57th Annual Meeting of the Association for Computational Linguistics*, pages 2346–2357, 2019.
575. Elena Voita, David Talbot, Fedor Moiseev, Rico Sennrich, and Ivan Titov. Analyzing Multi-Head Self-Attention: Specialized heads do the heavy lifting, the rest can be pruned. In *Proceedings of ACL*, pages 5797–5808, 2019.
576. Zhengyan Zhang, Fanchao Qi, Zhiyuan Liu, Qun Liu, and Maosong Sun. Know what you don’t need: Single-shot meta-pruning for attention heads. *AI Open*, 2:36–42, 2021.
577. Siqi Sun, Yu Cheng, Zhe Gan, and Jingjing Liu. Patient knowledge distillation for BERT model compression. In *Proceedings of EMNLP*, pages 4323–4332, 2019.
578. Ofir Zafrir, Guy Boudoukh, Peter Izsak, and Moshe Wasserblat. Q8BERT: Quantized 8bit BERT. *arXiv preprint 1910.06188*, October 2019.
579. Wei Zhang, Lu Hou, Yichun Yin, Lifeng Shang, Xiao Chen, Xin Jiang, and Qun Liu. TernaryBERT: Distillation-aware ultra-low bit BERT. In *Proceedings of EMNLP*, pages 509–521, 2020.
580. Ji Xin, Raphael Tang, Jaejun Lee, Yaoliang Yu, and Jimmy Lin. DeeBERT: Dynamic early exiting for accelerating BERT inference. In *Proceedings of ACL*, pages 2246–2251, 2020.
581. Lei Li, Yankai Lin, Deli Chen, Shuhuai Ren, Peng Li, Jie Zhou, and Xu Sun. CascadeBERT: Accelerating inference of pre-trained language models via calibrated complete models cascade. In *Findings of EMNLP*, pages 475–486, 2021.
582. Angela Fan, Edouard Grave, and Armand Joulin. Reducing transformer depth on demand with structured dropout. In *Proceedings of ICLR*, 2019.
583. Wenhui Wang, Furu Wei, Li Dong, Hangbo Bao, Nan Yang, and Ming Zhou. Minilm: Deep self-attention distillation for task-agnostic compression of pre-trained transformers. In *Proceedings of NeurIPS*, 2020.

584. Pierre Stock, Armand Joulin, Rémi Gribonval, Benjamin Graham, and Hervé Jégou. And the bit goes down: Revisiting the quantization of neural networks. In *Proceedings of ICLR*, 2020.
585. Sheng Shen, Zhen Dong, Jiayu Ye, Linjian Ma, Zhewei Yao, Amir Gholami, Michael W Mahoney, and Kurt Keutzer. Q-bert: Hessian based ultra low precision quantization of bert. In *Proceedings of AAAI*, pages 8815–8821, 2020.
586. Noam Chomsky. *Aspects of the Theory of Syntax*. MIT Press, 1965.
587. Noam Chomsky. *Syntactic structures*. De Gruyter, 1957.
588. Barr Avron and Edward A Feigenbaum. *The handbook of artificial intelligence*. 1981.
589. Frederick Hayes-Roth, Donald A Waterman, and Douglas B Lenat. *Building expert system*. 1983.
590. Leo Breiman, Jerome Friedman, Charles J Stone, and Richard A Olshen. *Classification and regression trees*. CRC press, 1984.
591. Jian Tang, Meng Qu, Mingzhe Wang, Ming Zhang, Jun Yan, and Qiaozhu Mei. Line: Large-scale information network embedding. In *Proceedings of WWW*, pages 1067–1077, 2015.
592. Kelvin Guu, Kenton Lee, Zora Tung, Panupong Pasupat, and Mingwei Chang. Retrieval augmented language model pre-training. In *International Conference on Machine Learning*, pages 3929–3938. PMLR, 2020.
593. Zhenghao Liu, Chenyan Xiong, Maosong Sun, and Zhiyuan Liu. Entity-duet neural ranking: Understanding the role of knowledge graph semantics in neural information retrieval. In *Proceedings of ACL*, 2018.
594. Diya Li, Lifu Huang, Heng Ji, and Jiawei Han. Biomedical event extraction based on knowledge-driven tree-lstm. In *Proceedings of NAACL*, pages 1421–1430, 2019.
595. Jason Weston, Sumit Chopra, and Antoine Bordes. Memory networks. In *Proceedings of ICLR*, 2015.
596. Qingyun Wang, Lifu Huang, Zhiying Jiang, Kevin Knight, Heng Ji, Mohit Bansal, and Yi Luan. Paperrobot: Incremental draft generation of scientific ideas. In *Proceedings of ACL*, pages 1980–1991, 2019.
597. Yihong Gu, Jun Yan, Hao Zhu, Zhiyuan Liu, Ruobing Xie, Maosong Sun, Fen Lin, and Leyu Lin. Language modeling with sparse product of sememe experts. In *Proceedings of EMNLP*, pages 4642–4651, 2018.
598. Ji Xin, Yankai Lin, Zhiyuan Liu, and Maosong Sun. Improving neural fine-grained entity typing with knowledge attention. In *Proceedings of AAAI*, pages 5997–6004, 2018.
599. Xu Han, Zhiyuan Liu, and Maosong Sun. Neural knowledge acquisition via mutual attention between knowledge graph and text. In *Proceedings of AAAI*, 2018.
600. Pei Ke, Haozhe Ji, Siyang Liu, Xiaoyan Zhu, and Minlie Huang. Sentilare: Linguistic knowledge enhanced language representation for sentiment analysis. In *Proceedings of the 2020 Conference on Empirical Methods in Natural Language Processing (EMNLP)*, pages 6975–6988, 2020.
601. Yuxian Gu, Zhengyan Zhang, Xiaozhi Wang, Zhiyuan Liu, and Maosong Sun. Train no evil: Selective masking for task-guided pre-training. In *Proceedings of EMNLP*, pages 6966–6974, 2020.
602. Geoffrey E. Hinton, Oriol Vinyals, and J. Dean. Distilling the knowledge in a neural network. *ArXiv*, abs/1503.02531, 2015.
603. Xiao Liu, Fanjin Zhang, Zhenyu Hou, Zhaoyu Wang, Li Mian, Jing Zhang, and Jie Tang. Self-supervised learning: Generative or contrastive. *arXiv preprint arXiv:2006.08218*, 2020.
604. Timo Schick, Helmut Schmid, and Hinrich Schütze. Automatically identifying words that can serve as labels for few-shot text classification. In *Proceedings of COLING*, pages 5569–5578, 2020.
605. Taylor Shin, Yasaman Razeghi, Robert L Logan IV, Eric Wallace, and Sameer Singh. Eliciting knowledge from language models using automatically generated prompts. In *Proceedings of EMNLP*, pages 4222–4235, 2020.
606. Maxime Oquab, Leon Bottou, Ivan Laptev, and Josef Sivic. Learning and transferring mid-level image representations using convolutional neural networks. In *Proceedings of the IEEE conference on computer vision and pattern recognition*, pages 1717–1724, 2014.
607. Carl Doersch, Ankush Gupta, and Andrew Zisserman. Crosstransformers: spatially-aware few-shot transfer. *Advances in Neural Information Processing Systems*, 33:21981–21993, 2020.
608. Deepak Pathak, Philipp Krahenbuhl, Jeff Donahue, Trevor Darrell, and Alexei A Efros. Context encoders: Feature learning by inpainting. In *Proceedings of the IEEE conference on computer vision and pattern recognition*, pages 2536–2544, 2016.
609. Richard Zhang, Phillip Isola, and Alexei A Efros. Colorful image colorization. In *European conference on computer vision*, pages 649–666. Springer, 2016.
610. Mehdi Noroozi and Paolo Favaro. Unsupervised learning of visual representations by solving jigsaw puzzles. In *European conference on computer vision*, pages 69–84. Springer, 2016.
611. Kaiming He, Xinlei Chen, Saining Xie, Yanghao Li, Piotr Dollár, and Ross Girshick. Masked autoencoders are scalable vision learners. *arXiv preprint arXiv:2111.06377*, 2021.
612. Pascal Vincent, Hugo Larochelle, Yoshua Bengio, and Pierre-Antoine Manzagol. Extracting and composing robust features with denoising autoencoders. In *Proceedings of the 25th international conference on Machine learning*, pages 1096–1103, 2008.
613. Kaiming He, Haoqi Fan, Yuxin Wu, Saining Xie, and Ross Girshick. Momentum contrast for unsupervised visual representation learning. In *Proceedings of the IEEE/CVF conference on computer vision and pattern recognition*, pages 9729–9738, 2020.
614. Mathilde Caron, Piotr Bojanowski, Armand Joulin, and Matthijs Douze. Deep clustering for unsupervised learning of visual features. In *Proceedings of the European conference on computer vision (ECCV)*, pages 132–149, 2018.
615. Karen Simonyan and Andrew Zisserman. Very deep convolutional networks for large-scale image recognition. *Computer Science*, 2014.

616. Christian Szegedy, Wei Liu, Yangqing Jia, Pierre Sermanet, Scott Reed, Dragomir Anguelov, Dumitru Erhan, Vincent Vanhoucke, and Andrew Rabinovich. Going deeper with convolutions. In *Proceedings of the IEEE conference on computer vision and pattern recognition*, pages 1–9, 2015.
617. Kaiming He, Xiangyu Zhang, Shaoqing Ren, and Jian Sun. Deep residual learning for image recognition. In *Proceedings of the IEEE conference on computer vision and pattern recognition*, pages 770–778, 2016.
618. Andrew G Howard, Menglong Zhu, Bo Chen, Dmitry Kalenichenko, Weijun Wang, Tobias Weyand, Marco Andreetto, and Hartwig Adam. Mobilenets: Efficient convolutional neural networks for mobile vision applications. *arXiv preprint arXiv:1704.04861*, 2017.
619. Mark Sandler, Andrew Howard, Menglong Zhu, Andrey Zhmoginov, and Liang-Chieh Chen. Mobilenetv2: Inverted residuals and linear bottlenecks. In *Proceedings of the IEEE conference on computer vision and pattern recognition*, pages 4510–4520, 2018.
620. Xiangyu Zhang, Xinyu Zhou, Mengxiao Lin, and Jian Sun. Shufflenet: An extremely efficient convolutional neural network for mobile devices. In *Proceedings of the IEEE conference on computer vision and pattern recognition*, pages 6848–6856, 2018.
621. Hugo Touvron, Matthieu Cord, Matthijs Douze, Francisco Massa, Alexandre Sablayrolles, and Hervé Jégou. Training data-efficient image transformers & distillation through attention. In *International Conference on Machine Learning*, pages 10347–10357. PMLR, 2021.
622. Yulin Wang, Rui Huang, Shiji Song, Zeyi Huang, and Gao Huang. Not all images are worth 16x16 words: Dynamic transformers for efficient image recognition. In *Advances in Neural Information Processing Systems (NeurIPS)*, 2021.
623. Yongming Rao, Wenliang Zhao, Benlin Liu, Jiwen Lu, Jie Zhou, and Cho-Jui Hsieh. Dynamicvit: Efficient vision transformers with dynamic token sparsification. In *Advances in Neural Information Processing Systems (NeurIPS)*, 2021.
624. Namuk Park and Songkuk Kim. How do vision transformers work? In *International Conference on Learning Representations*, 2022.
625. Zihang Dai, Hanxiao Liu, Quoc V Le, and Mingxing Tan. Coatnet: Marrying convolution and attention for all data sizes. *arXiv preprint arXiv:2106.04803*, 2021.
626. Ilya O Tolstikhin, Neil Houlsby, Alexander Kolesnikov, Lucas Beyer, Xiaohua Zhai, Thomas Unterthiner, Jessica Yung, Andreas Steiner, Daniel Keysers, Jakob Uszkoreit, et al. Mlp-mixer: An all-mlp architecture for vision. *Advances in Neural Information Processing Systems*, 34, 2021.
627. Hugo Touvron, Piotr Bojanowski, Mathilde Caron, Alaaeldin El-Nouby, Edouard Grave, Gautier Izacard, Armand Joulin, Gabriel Synnaeve, Jakob Verbeek, et al. Resmlp: Feedforward networks for image classification with data-efficient training. *arXiv preprint arXiv:2105.03404*, 2021.
628. Yongming Rao, Wenliang Zhao, Zheng Zhu, Jiwen Lu, and Jie Zhou. Global filter networks for image classification. *Advances in Neural Information Processing Systems*, 34, 2021.
629. Kaiming He, Xiangyu Zhang, Shaoqing Ren, and Jian Sun. Delving deep into rectifiers: Surpassing human-level performance on imagenet classification. In *Proceedings of the IEEE international conference on computer vision*, pages 1026–1034, 2015.
630. Xiaohua Zhai, Kolesnikov Alexander, Houlsby Neil, and Beyer Lucas. Scaling vision transformers. *arXiv preprint arXiv:2106.04560*, 2021.
631. Carlos Riquelme, Joan Puigcerver, Basil Mustafa, Maxim Neumann, Rodolphe Jenatton, André Susano Pinto, Daniel Keysers, and Neil Houlsby. Scaling vision with sparse mixture of experts. *Advances in Neural Information Processing Systems*, 34, 2021.
632. Ze Liu, Han Hu, Yutong Lin, Zhuliang Yao, Zhenda Xie, Yixuan Wei, Jia Ning, Yue Cao, Zheng Zhang, Li Dong, et al. Swin transformer v2: Scaling up capacity and resolution. *arXiv preprint arXiv:2111.09883*, 2021.
633. Alexey Dosovitskiy, Jost Tobias Springenberg, Martin Riedmiller, and Thomas Brox. Discriminative unsupervised feature learning with convolutional neural networks. *Advances in neural information processing systems*, 27, 2014.
634. R Devon Hjelm, Alex Fedorov, Samuel Lavoie-Marchildon, Karan Grewal, Phil Bachman, Adam Trischler, and Yoshua Bengio. Learning deep representations by mutual information estimation and maximization. *arXiv preprint arXiv:1808.06670*, 2018.
635. Xinlei Chen, Haoqi Fan, Ross Girshick, and Kaiming He. Improved baselines with momentum contrastive learning. *arXiv preprint arXiv:2003.04297*, 2020.
636. Jean-Bastien Grill, Florian Strub, Florent Altché, Corentin Tallec, Pierre Richemond, Elena Buchatskaya, Carl Doersch, Bernardo Avila Pires, Zhaohan Guo, Mohammad Gheshlaghi Azar, et al. Bootstrap your own latent—a new approach to self-supervised learning. *Advances in Neural Information Processing Systems*, 33:21271–21284, 2020.
637. Junyuan Xie, Ross Girshick, and Ali Farhadi. Unsupervised deep embedding for clustering analysis. In *International conference on machine learning*, pages 478–487. PMLR, 2016.
638. Stuart Lloyd. Least squares quantization in pcm. *IEEE transactions on information theory*, 28(2):129–137, 1982.
639. Mathilde Caron, Ishan Misra, Julien Mairal, Priya Goyal, Piotr Bojanowski, and Armand Joulin. Unsupervised learning of visual features by contrasting cluster assignments. *Advances in Neural Information Processing Systems*, 33:9912–9924, 2020.
640. Wouter Van Gansbeke, Simon Vandenhende, Stamatios Georgoulis, Marc Proesmans, and Luc Van Gool. Scan: Learning to classify images without labels. In *European Conference on Computer Vision*, pages 268–285. Springer, 2020.
641. Carl Doersch, Abhinav Gupta, and Alexei A Efros. Unsupervised visual representation learning by context prediction. In *Proceedings of the IEEE international conference on computer vision*, pages 1422–1430, 2015.

642. Jacob Devlin, Ming-Wei Chang, Kenton Lee, and Kristina Toutanova. Bert: Pre-training of deep bidirectional transformers for language understanding. *arXiv preprint arXiv:1810.04805*, 2018.
643. Hangbo Bao, Li Dong, and Furu Wei. Beit: Bert pre-training of image transformers. *arXiv preprint arXiv:2106.08254*, 2021.
644. Dong-Hyun Lee et al. Pseudo-label: The simple and efficient semi-supervised learning method for deep neural networks. In *Workshop on challenges in representation learning, ICML*, volume 3, page 896, 2013.
645. Antti Tarvainen and Harri Valpola. Mean teachers are better role models: Weight-averaged consistency targets improve semi-supervised deep learning results. *Advances in neural information processing systems*, 30, 2017.
646. David Berthelot, Nicholas Carlini, Ian Goodfellow, Nicolas Papernot, Avital Oliver, and Colin A Raffel. Mixmatch: A holistic approach to semi-supervised learning. *Advances in Neural Information Processing Systems*, 32, 2019.
647. Hongyi Zhang, Moustapha Cisse, Yann N Dauphin, and David Lopez-Paz. mixup: Beyond empirical risk minimization. *arXiv preprint arXiv:1710.09412*, 2017.
648. Qizhe Xie, Minh-Thang Luong, Eduard Hovy, and Quoc V Le. Self-training with noisy student improves imagenet classification. In *Proceedings of the IEEE/CVF Conference on Computer Vision and Pattern Recognition*, pages 10687–10698, 2020.
649. Hieu Pham, Zihang Dai, Qizhe Xie, and Quoc V Le. Meta pseudo labels. In *Proceedings of the IEEE/CVF Conference on Computer Vision and Pattern Recognition*, pages 11557–11568, 2021.
650. Dhruv Mahajan, Ross Girshick, Vignesh Ramanathan, Kaiming He, Manohar Paluri, Yixuan Li, Ashwin Bharambe, and Laurens Van Der Maaten. Exploring the limits of weakly supervised pretraining. In *Proceedings of the European conference on computer vision (ECCV)*, pages 181–196, 2018.
651. Alec Radford, Jong Wook Kim, Chris Hallacy, Aditya Ramesh, Gabriel Goh, Sandhini Agarwal, Girish Sastry, Amanda Askell, Pamela Mishkin, Jack Clark, et al. Learning transferable visual models from natural language supervision. In *International Conference on Machine Learning*, pages 8748–8763. PMLR, 2021.
652. Zhaowei Cai and Nuno Vasconcelos. Cascade r-cnn: Delving into high quality object detection. In *Proceedings of the IEEE conference on computer vision and pattern recognition*, pages 6154–6162, 2018.
653. Yihong Chen, Zheng Zhang, Yue Cao, Liwei Wang, Stephen Lin, and Han Hu. Reppoints v2: Verification meets regression for object detection. *Advances in Neural Information Processing Systems*, 33:5621–5631, 2020.
654. Peize Sun, Rufeng Zhang, Yi Jiang, Tao Kong, Chenfeng Xu, Wei Zhan, Masayoshi Tomizuka, Lei Li, Zehuan Yuan, Changhu Wang, et al. Sparse r-cnn: End-to-end object detection with learnable proposals. In *Proceedings of the IEEE/CVF Conference on Computer Vision and Pattern Recognition*, pages 14454–14463, 2021.
655. Nicolas Carion, Francisco Massa, Gabriel Synnaeve, Nicolas Usunier, Alexander Kirillov, and Sergey Zagoruyko. End-to-end object detection with transformers. In *European conference on computer vision*, pages 213–229. Springer, 2020.
656. Kaiming He, Georgia Gkioxari, Piotr Dollár, and Ross Girshick. Mask r-cnn. In *Proceedings of the IEEE international conference on computer vision*, pages 2961–2969, 2017.
657. Bowen Cheng, Alex Schwing, and Alexander Kirillov. Per-pixel classification is not all you need for semantic segmentation. *Advances in Neural Information Processing Systems*, 34, 2021.
658. Shi Guo, Zifei Yan, Kai Zhang, Wangmeng Zuo, and Lei Zhang. Toward convolutional blind denoising of real photographs. In *Proceedings of the IEEE/CVF conference on computer vision and pattern recognition*, pages 1712–1722, 2019.
659. Chao Dong, Chen Change Loy, Kaiming He, and Xiaoou Tang. Learning a deep convolutional network for image super-resolution. In *European conference on computer vision*, pages 184–199. Springer, 2014.
660. Xiaowei Hu, Chi-Wing Fu, Lei Zhu, and Pheng-Ann Heng. Depth-attentional features for single-image rain removal. In *Proceedings of the IEEE/CVF Conference on Computer Vision and Pattern Recognition*, pages 8022–8031, 2019.
661. Hanting Chen, Yunhe Wang, Tianyu Guo, Chang Xu, Yiping Deng, Zhenhua Liu, Siwei Ma, Chunjing Xu, Chao Xu, and Wen Gao. Pre-trained image processing transformer. In *Proceedings of the IEEE/CVF Conference on Computer Vision and Pattern Recognition*, pages 12299–12310, 2021.
662. Nitish Srivastava, Elman Mansimov, and Ruslan Salakhudinov. Unsupervised learning of video representations using lstms. In *International conference on machine learning*, pages 843–852. PMLR, 2015.
663. Ishan Misra, C Lawrence Zitnick, and Martial Hebert. Shuffle and learn: unsupervised learning using temporal order verification. In *European Conference on Computer Vision*, pages 527–544. Springer, 2016.
664. Carl Vondrick, Abhinav Shrivastava, Alireza Fathi, Sergio Guadarrama, and Kevin Murphy. Tracking emerges by coloring videos. In *Proceedings of the European conference on computer vision (ECCV)*, pages 391–408, 2018.
665. Rui Qian, Tianjian Meng, Boqing Gong, Ming-Hsuan Yang, Huisheng Wang, Serge Belongie, and Yin Cui. Spatiotemporal contrastive video representation learning. In *Proceedings of the IEEE/CVF Conference on Computer Vision and Pattern Recognition*, pages 6964–6974, 2021.
666. Rui Li, Yiheng Zhang, Zhaofan Qiu, Ting Yao, Dong Liu, and Tao Mei. Motion-focused contrastive learning of video representations. In *Proceedings of the IEEE/CVF International Conference on Computer Vision*, pages 2105–2114, 2021.
667. Charles R Qi, Hao Su, Matthias Nießner, Angela Dai, Mengyuan Yan, and Leonidas J Guibas. Volumetric and multi-view cnns for object classification on 3d data. In *Proceedings of the IEEE conference on computer vision and pattern recognition*, pages 5648–5656, 2016.
668. Charles R Qi, Hao Su, Kaichun Mo, and Leonidas J Guibas. Pointnet: Deep learning on point sets for 3d classification and segmentation. In *Proceedings of the IEEE conference on computer vision and pattern recognition*, pages 652–660, 2017.



669. Rohit Girdhar, Mannat Singh, Nikhila Ravi, Laurens van der Maaten, Armand Joulin, and Ishan Misra. Omnivore: A single model for many visual modalities. *arXiv preprint arXiv:2201.08377*, 2022.
670. Linqing Zhao, Jiwen Lu, and Jie Zhou. Similarity-aware fusion network for 3d semantic segmentation. In *2021 IEEE/RSJ International Conference on Intelligent Robots and Systems (IROS)*, pages 1585–1592. IEEE, 2021.
671. Yue Wang, Vitor Campagnolo Guizilini, Tianyuan Zhang, Yilun Wang, Hang Zhao, and Justin Solomon. Detr3d: 3d object detection from multi-view images via 3d-to-2d queries. In *Conference on Robot Learning*, pages 180–191. PMLR, 2022.
672. Yunpeng Zhang, Jiwen Lu, and Jie Zhou. Objects are different: Flexible monocular 3d object detection. In *Proceedings of the IEEE/CVF Conference on Computer Vision and Pattern Recognition*, pages 3289–3298, 2021.
673. Divya Kumari and Subrahmanya Bhat. Application of artificial intelligence technology in tesla-a case study. *International Journal of Applied Engineering and Management Letters (IJAEML)*, 5(2):205–218, 2021.
674. Andrew Jaegle, Felix Gimeno, Andy Brock, Oriol Vinyals, Andrew Zisserman, and Joao Carreira. Perceiver: General perception with iterative attention. In *International Conference on Machine Learning*, pages 4651–4664. PMLR, 2021.
675. Andrew Jaegle, Sebastian Borgeaud, Jean-Baptiste Alayrac, Carl Doersch, Catalin Ionescu, David Ding, Skanda Koppula, Daniel Zoran, Andrew Brock, Evan Shelhamer, et al. Perceiver io: A general architecture for structured inputs & outputs. *arXiv preprint arXiv:2107.14795*, 2021.
676. Tanmay Gupta, Amita Kamath, Aniruddha Kembhavi, and Derek Hoiem. Towards general purpose vision systems. *arXiv preprint arXiv:2104.00743*, 2021.
677. Qing Li, Boqing Gong, Yin Cui, Dan Kondratyuk, Xianzhi Du, Ming-Hsuan Yang, and Matthew Brown. Towards a unified foundation model: Jointly pre-training transformers on unpaired images and text. *arXiv preprint arXiv:2112.07074*, 2021.
678. Alexei Baevski, Wei-Ning Hsu, Qiantong Xu, Arun Babu, Jiatao Gu, and Michael Auli. data2vec: A general framework for self-supervised learning in speech, vision and language. *arXiv preprint arXiv:2202.03555*, 2022.
679. Hanrui Wang, Zhonghao Wu, Zhijian Liu, Han Cai, Ligeng Zhu, Chuang Gan, and Song Han. Hat: Hardware-aware transformers for efficient natural language processing. *arXiv preprint arXiv:2005.14187*, 2020.
680. Bingbing Li, Santosh Pandey, Haowen Fang, Yanjun Lyv, Ji Li, Jieyang Chen, Mimi Xie, Lipeng Wan, Hang Liu, and Caiwen Ding. Ftrans: energy-efficient acceleration of transformers using fpga. In *Proceedings of the ACM/IEEE International Symposium on Low Power Electronics and Design*, pages 175–180, 2020.
681. Yizeng Han, Gao Huang, Shiji Song, Le Yang, Honghui Wang, and Yulin Wang. Dynamic neural networks: A survey. *IEEE Transactions on Pattern Analysis and Machine Intelligence*, 2021.
682. Gao Huang, Danlu Chen, Tianhong Li, Felix Wu, Laurens Van Der Maaten, and Kilian Q Weinberger. Multi-scale dense networks for resource efficient image classification. *arXiv preprint arXiv:1703.09844*, 2017.
683. Surat Teerapittayanon, Bradley McDanel, and Hsiang-Tsung Kung. Branchynet: Fast inference via early exiting from deep neural networks. In *2016 23rd International Conference on Pattern Recognition (ICPR)*, pages 2464–2469. IEEE, 2016.
684. Ningning Ma, Xiangyu Zhang, and Jian Sun. Funnel activation for visual recognition. In *European Conference on Computer Vision*, pages 351–368. Springer, 2020.
685. Xiang Li, Wenhai Wang, Xiaolin Hu, and Jian Yang. Selective kernel networks. In *Proceedings of the IEEE/CVF Conference on Computer Vision and Pattern Recognition*, pages 510–519, 2019.
686. Hehe Fan, Zhongwen Xu, Linchao Zhu, Chenggang Yan, Jianjun Ge, and Yi Yang. Watching a small portion could be as good as watching all: Towards efficient video classification. In *IJCAI International Joint Conference on Artificial Intelligence*, 2018.
687. Wenhao Wu, Dongliang He, Xiao Tan, Shifeng Chen, Yi Yang, and Shilei Wen. Dynamic inference: A new approach toward efficient video action recognition. In *Proceedings of the IEEE/CVF Conference on Computer Vision and Pattern Recognition Workshops*, pages 676–677, 2020.
688. Bolei Zhou, Aditya Khosla, Agata Lapedriza, Aude Oliva, and Antonio Torralba. Learning deep features for discriminative localization. In *CVPR*, pages 2921–2929, 2016.
689. Ramprasaath R Selvaraju, Michael Cogswell, Abhishek Das, Ramakrishna Vedantam, Devi Parikh, and Dhruv Batra. Grad-cam: Visual explanations from deep networks via gradient-based localization. In *ICCV*, pages 618–626, 2017.
690. Quanshi Zhang, Yu Yang, Haotian Ma, and Ying Nian Wu. Interpreting cnns via decision trees. In *CVPR*, pages 6261–6270, 2019.
691. Muhammad Muzammal Naseer, Kanchana Ranasinghe, Salman H Khan, Munawar Hayat, Fahad Shahbaz Khan, and Ming-Hsuan Yang. Intriguing properties of vision transformers. *Advances in Neural Information Processing Systems*, 34, 2021.
692. Hila Chefer, Shir Gur, and Lior Wolf. Transformer interpretability beyond attention visualization. In *Proceedings of the IEEE/CVF Conference on Computer Vision and Pattern Recognition*, pages 782–791, 2021.
693. Chao Jia, Yinfei Yang, Ye Xia, Yi-Ting Chen, Zarana Parekh, Hieu Pham, Quoc V Le, Yunhsuan Sung, Zhen Li, and Tom Duerig. Scaling up visual and vision-language representation learning with noisy text supervision. *arXiv preprint arXiv:2102.05918*, 2021.
694. Nanyi Fei, Zhiwu Lu, Yizhao Gao, Guoxing Yang, Yuqi Huo, Jingyuan Wen, Haoyu Lu, Ruihua Song, Xin Gao, Tao Xiang, et al. Wenlan 2.0: Make ai imagine via a multimodal foundation model. *arXiv preprint arXiv:2110.14378*, 2021.
695. J. Li, R. R. Selvaraj U, A. D. Gotmare, S. Joty, C. Xiong, and S. Hoi. Align before fuse: Vision and language representation learning with momentum distillation. 2021.

696. Z. Wang, J. Yu, A. W. Yu, Z. Dai, and Y. Cao. Simvlm: Simple visual language model pretraining with weak supervision. 2021.
697. Liunian Harold Li, Mark Yatskar, Da Yin, Cho-Jui Hsieh, and Kai-Wei Chang. Visualbert: A simple and performant baseline for vision and language. *arXiv preprint arXiv:1908.03557*, 2019.
698. Yen-Chun Chen, Linjie Li, Licheng Yu, Ahmed El Kholy, Faisal Ahmed, Zhe Gan, Yu Cheng, and Jingjing Liu. Uniter: Universal image-text representation learning. In *European conference on computer vision*, pages 104–120. Springer, 2020.
699. Wei Li, Can Gao, Guocheng Niu, Xinyan Xiao, Hao Liu, Jiachen Liu, Hua Wu, and Haifeng Wang. Unimo: Towards unified-modal understanding and generation via cross-modal contrastive learning. *arXiv preprint arXiv:2012.15409*, 2020.
700. Xiujun Li, Xi Yin, Chunyuan Li, Pengchuan Zhang, Xiaowei Hu, Lei Zhang, Lijuan Wang, Houdong Hu, Li Dong, Furu Wei, et al. Oscar: Object-semantics aligned pre-training for vision-language tasks. In *European Conference on Computer Vision*, pages 121–137. Springer, 2020.
701. W. L. Taylor. "cloze procedure": A new tool for measuring readability. *The journalism quarterly*, 30(4):415–433, 1953.
702. Jiasen Lu, Dhruv Batra, Devi Parikh, and Stefan Lee. Vilbert: Pretraining task-agnostic visiolinguistic representations for vision-and-language tasks. *arXiv preprint arXiv:1908.02265*, 2019.
703. J. Lin, A. Yang, Y. Zhang, J. Liu, J. Zhou, and H. Yang. Interbert: An effective multi-modal pretraining approach via vision-and-language interaction. 2020.
704. Nedjma Djouhra Ousidhoum, Xinran Zhao, Tianqing Fang, Yangqiu Song, and Dit Yan Yeung. Probing toxic content in large pre-trained language models. In *Proceedings of the 59th Annual Meeting of the Association for Computational Linguistics and the 11th International Joint Conference on Natural Language Processing*, 2021.
705. Z. Huang, Z. Zeng, Y. Huang, B. Liu, D. Fu, and J. Fu. Seeing out of the box: End-to-end pre-training for vision-language representation learning. 2021.
706. Alexis Conneau, Kartikay Khandelwal, Naman Goyal, Vishrav Chaudhary, Guillaume Wenzek, Francisco Guzmán, Edouard Grave, Myle Ott, Luke Zettlemoyer, and Veselin Stoyanov. Unsupervised cross-lingual representation learning at scale. *arXiv preprint arXiv:1911.02116*, 2019.
707. J. Lu, V. Goswami, M. Rohrbach, D. Parikh, and S. Lee. 12-in-1: Multi-task vision and language representation learning. In *2020 IEEE/CVF Conference on Computer Vision and Pattern Recognition (CVPR)*, 2020.
708. Mateusz Malinowski and Mario Fritz. A multi-world approach to question answering about real-world scenes based on uncertain input. *Advances in neural information processing systems*, 27:1682–1690, 2014.
709. Ranjay Krishna, Yuke Zhu, Oliver Groth, Justin Johnson, Kenji Hata, Joshua Kravitz, Stephanie Chen, Yannis Kalantidis, Li-Jia Li, David A Shamma, et al. Visual genome: Connecting language and vision using crowdsourced dense image annotations. *International journal of computer vision*, 123(1):32–73, 2017.
710. Mengye Ren, Ryan Kiros, and Richard Zemel. Exploring models and data for image question answering. *Advances in neural information processing systems*, 28:2953–2961, 2015.
711. Stanislaw Antol, Aishwarya Agrawal, Jiasen Lu, Margaret Mitchell, Dhruv Batra, C Lawrence Zitnick, and Devi Parikh. Vqa: Visual question answering. In *Proceedings of the IEEE international conference on computer vision*, pages 2425–2433, 2015.
712. Drew A Hudson and Christopher D Manning. Gqa: A new dataset for real-world visual reasoning and compositional question answering. In *Proceedings of the IEEE/CVF conference on computer vision and pattern recognition*, pages 6700–6709, 2019.
713. Alane Suhr, Mike Lewis, James Yeh, and Yoav Artzi. A corpus of natural language for visual reasoning. In *Proceedings of the 55th Annual Meeting of the Association for Computational Linguistics (Volume 2: Short Papers)*, pages 217–223, 2017.
714. Bryan A Plummer, Liwei Wang, Chris M Cervantes, Juan C Caicedo, Julia Hockenmaier, and Svetlana Lazebnik. Flickr30k entities: Collecting region-to-phrase correspondences for richer image-to-sentence models. In *Proceedings of the IEEE international conference on computer vision*, pages 2641–2649, 2015.
715. Tsung-Yi Lin, Michael Maire, Serge Belongie, James Hays, Pietro Perona, Deva Ramanan, Piotr Dollár, and C Lawrence Zitnick. Microsoft COCO: common objects in context. In *ECCV*, 2014.
716. J. Cho, J. Lu, D. Schwenk, H. Hajishirzi, and A. Kembhavi. X-lxmert: Paint, caption and answer questions with multi-modal transformers. 2020.
717. Zhengyan Zhang, Xu Han, Zhiyuan Liu, Xin Jiang, Maosong Sun, and Qun Liu. ERNIE: enhanced language representation with informative entities. In Anna Korhonen, David R. Traum, and Lluís Màrquez, editors, *Proceedings of the 57th Conference of the Association for Computational Linguistics, ACL 2019, Florence, Italy, July 28- August 2, 2019, Volume 1: Long Papers*, pages 1441–1451. Association for Computational Linguistics, 2019.
718. Q. Xia, H. Huang, N. Duan, D. Zhang, and M. Zhou. Xgpt: Cross-modal generative pre-training for image captioning. 2020.
719. J. Cho, J. Lei, H. Tan, and M. Bansal. Unifying vision-and-language tasks via text generation. 2021.
720. Kishore Papineni, Salim Roukos, Todd Ward, and Wei-Jing Zhu. Bleu: a method for automatic evaluation of machine translation. In *Proceedings of the 40th annual meeting of the Association for Computational Linguistics*, pages 311–318, 2002.
721. Satanjeev Banerjee and Alon Lavie. Meteor: An automatic metric for mt evaluation with improved correlation with human judgments. In *Proceedings of the acl workshop on intrinsic and extrinsic evaluation measures for machine translation and/or summarization*, pages 65–72, 2005.

722. Ramakrishna Vedantam, C Lawrence Zitnick, and Devi Parikh. Cider: Consensus-based image description evaluation. In *Proceedings of the IEEE conference on computer vision and pattern recognition*, pages 4566–4575, 2015.
723. Peter Anderson, Basura Fernando, Mark Johnson, and Stephen Gould. Spice: Semantic propositional image caption evaluation. In *European conference on computer vision*, pages 382–398. Springer, 2016.
724. Harsh Agrawal, Karan Desai, Yufei Wang, Xinlei Chen, Rishabh Jain, Mark Johnson, Dhruv Batra, Devi Parikh, Stefan Lee, and Peter Anderson. nocaps: novel object captioning at scale. In *Proceedings of the IEEE International Conference on Computer Vision*, pages 8948–8957, 2019.
725. Max Bain, Arsha Nagrani, Gül Varol, and Andrew Zisserman. Frozen in time: A joint video and image encoder for end-to-end retrieval. *arXiv preprint arXiv:2104.00650*, 2021.
726. Antoine Miech, Dimitri Zhukov, Jean-Baptiste Alayrac, Makarand Tapaswi, Ivan Laptev, and Josef Sivic. HowTo100M: Learning a text-video embedding by watching hundred million narrated video clips. In *ICCV*, pages 2630–2640, 2019.
727. Aashi Jain, Mandy Guo, Krishna Srinivasan, Ting Chen, Sneha Kudugunta, Chao Jia, Yinfei Yang, and Jason Baldridge. Mural: Multimodal, multitask retrieval across languages. *arXiv preprint arXiv:2109.05125*, 2021.
728. Mingyang Zhou, Luwei Zhou, Shuohang Wang, Yu Cheng, Linjie Li, Zhou Yu, and Jingjing Liu. Uc2: Universal cross-lingual cross-modal vision-and-language pre-training. In *Proceedings of the IEEE/CVF Conference on Computer Vision and Pattern Recognition*, pages 4155–4165, 2021.
729. Cong Fang, Hanze Dong, and Tong Zhang. Mathematical models of overparameterized neural networks. *Proceedings of the IEEE*, 109(5):683–703, 2021.
730. Arthur Jacot, Franck Gabriel, and Clément Hongler. Neural tangent kernel: Convergence and generalization in neural networks. In *Advances in neural information processing systems*, 2018.
731. Yuanzhi Li and Yingyu Liang. Learning overparameterized neural networks via stochastic gradient descent on structured data. In *Advances in Neural Information Processing Systems*, 2018.
732. Simon S Du, Jason D Lee, Haochuan Li, Liwei Wang, and Xiyu Zhai. Gradient descent finds global minima of deep neural networks. In *International Conference on Machine Learning*, 2019.
733. Sanjeev Arora, Simon S Du, Wei Hu, Zhiyuan Li, and Ruosong Wang. Fine-grained analysis of optimization and generalization for overparameterized two-layer neural networks. In *International Conference on Machine Learning*, 2019.
734. Simon S Du, Xiyu Zhai, Barnabas Poczos, and Aarti Singh. Gradient descent provably optimizes over-parameterized neural networks. In *International Conference on Learning Representation*, 2019.
735. Zeyuan Allen-Zhu, Yuanzhi Li, and Yingyu Liang. Learning and generalization in overparameterized neural networks, going beyond two layers. *arXiv preprint arXiv:1811.04918*, 2018.
736. Zeyuan Allen-Zhu and Yuanzhi Li. Can sgd learn recurrent neural networks with provable generalization? *arXiv preprint arXiv:1902.01028*, 2019.
737. Zeyuan Allen-Zhu, Yuanzhi Li, and Zhao Song. A convergence theory for deep learning via over-parameterization. In *International Conference on Machine Learning*, 2019.
738. Difan Zou, Yuan Cao, Dongruo Zhou, and Quanquan Gu. Stochastic gradient descent optimizes over-parameterized deep relu networks. In *Advances in neural information processing systems*, 2018.
739. Samet Oymak and Mahdi Soltanolkotabi. Overparameterized nonlinear learning: Gradient descent takes the shortest path? *arXiv preprint arXiv:1812.10004*, 2018.
740. Song Mei, Andrea Montanari, and Phan-Minh Nguyen. A mean field view of the landscape of two-layer neural networks. *Proceedings of the National Academy of Sciences*, 115(33):E7665–E7671, 2018.
741. Lenaïc Chizat and Francis Bach. On the global convergence of gradient descent for over-parameterized models using optimal transport. In *Advances in neural information processing systems*, pages 3036–3046, 2018.
742. Justin Sirignano and Konstantinos Spiliopoulos. Mean field analysis of neural networks: A central limit theorem. *Stochastic Processes and their Applications*, 2019.
743. Song Mei, Theodor Misiakiewicz, and Andrea Montanari. Mean-field theory of two-layers neural networks: dimension-free bounds and kernel limit. In *Annual Conference on Learning Theory*, 2019.
744. Grant M Rotskoff and Eric Vanden-Eijnden. Neural networks as interacting particle systems: Asymptotic convexity of the loss landscape and universal scaling of the approximation error. *stat*, 1050:22, 2018.
745. Cong Fang, Jason Lee, Pengkun Yang, and Tong Zhang. Modeling from features: a mean-field framework for over-parameterized deep neural networks. In *Conference on learning theory*, pages 1887–1936. PMLR, 2021.
746. J. Quionero-Candela, M. Sugiyama, A. Schwaighofer, and N. D. Lawrence. *Dataset shift in machine learning*. The MIT Press, 2009.
747. Shai Ben-David, John Blitzer, Koby Crammer, Alex Kulesza, Fernando C Pereira, and Jennifer Wortman Vaughan. A theory of learning from different domains. *Machine Learning*, 2009.
748. Y. Mansour, Mehryar Mohri, and Afshin Rostamizadeh. Domain adaptation: Learning bounds and algorithms. *COLT*, 2009.
749. Corinna Cortes, Mehryar Mohri, and Andrés Muñoz Medina. Adaptation algorithm and theory based on generalized discrepancy. In *KDD*, pages 169–178, 2015.
750. Nicolas Courty, Rémi Flamary, Amaury Habrard, and Alain Rakotomamonjy. Joint distribution optimal transportation for domain adaptation. In *NeurIPS*, volume 30, 2017.
751. Judy Hoffman, Mehryar Mohri, and Ningshan Zhang. Algorithms and theory for multiple-source adaptation. In *NeurIPS*, pages 8256–8266. 2018.

752. Fredrik D. Johansson, David Sontag, and Rajesh Ranganath. Support and invertibility in domain-invariant representations. In *AISTATS*, 2019.
753. Pascal Germain, Amaury Habrard, François Laviolette, and Emilie Morvant. A pac-bayesian approach for domain adaptation with specialization to linear classifiers. In *ICML*, pages 738–746, 2013.
754. Yuchen Zhang, Tianle Liu, Mingsheng Long, and Michael I. Jordan. Bridging theory and algorithm for domain adaptation. In *ICML*, 2019.
755. Aaron van den Oord, Yazhe Li, and Oriol Vinyals. Representation learning with contrastive predictive coding. *arXiv preprint arXiv:1807.03748*, 2018.
756. Chunyuan Li, Jianwei Yang, Pengchuan Zhang, Mei Gao, Bin Xiao, Xiyang Dai, Lu Yuan, and Jianfeng Gao. Efficient self-supervised vision transformers for representation learning. *arXiv preprint arXiv:2106.09785*, 2021.
757. Mark Chen, Alec Radford, Rewon Child, Jeffrey Wu, Heewoo Jun, David Luan, and Ilya Sutskever. Generative pretraining from pixels. In *ICML*, 2020.
758. Jason D Lee, Qi Lei, Nikunj Saunshi, and Jiacheng Zhuo. Predicting what you already know helps: Provable self-supervised learning. *arXiv preprint arXiv:2008.01064*, 2020.
759. Yao-Hung Hubert Tsai, Yue Wu, Ruslan Salakhutdinov, and Louis-Philippe Morency. Self-supervised learning from a multi-view perspective. In *ICLR*, 2021.
760. Christopher Tosh, Akshay Krishnamurthy, and Daniel Hsu. Contrastive learning, multi-view redundancy, and linear models. In *Proceedings of the 32nd International Conference on Algorithmic Learning Theory*, volume 132 of *Proceedings of Machine Learning Research*, pages 1179–1206. PMLR, 2021.
761. Jeff Z HaoChen, Colin Wei, Adrien Gaidon, and Tengyu Ma. Provable guarantees for self-supervised deep learning with spectral contrastive loss. In *NeurIPS*, 2021.
762. Karen Simonyan, Andrea Vedaldi, and Andrew Zisserman. Deep inside convolutional networks: Visualising image classification models and saliency maps. *arXiv preprint arXiv:1312.6034*, 2013.
763. Matthew D Zeiler and Rob Fergus. Visualizing and understanding convolutional networks. In *European conference on computer vision*, pages 818–833. Springer, 2014.
764. Aravindh Mahendran and Andrea Vedaldi. Understanding deep image representations by inverting them. In *Proceedings of the IEEE conference on computer vision and pattern recognition*, pages 5188–5196, 2015.
765. Alexey Dosovitskiy and Thomas Brox. Inverting visual representations with convolutional networks. In *Proceedings of the IEEE conference on computer vision and pattern recognition*, pages 4829–4837, 2016.
766. Scott M Lundberg and Su-In Lee. A unified approach to interpreting model predictions. In *Proceedings of the 31st international conference on neural information processing systems*, pages 4768–4777, 2017.
767. Ruth C Fong and Andrea Vedaldi. Interpretable explanations of black boxes by meaningful perturbation. In *Proceedings of the IEEE international conference on computer vision*, pages 3429–3437, 2017.
768. Bolei Zhou, Aditya Khosla, Agata Lapedriza, Aude Oliva, and Antonio Torralba. Learning deep features for discriminative localization. In *Proceedings of the IEEE conference on computer vision and pattern recognition*, pages 2921–2929, 2016.
769. Ramprasaath R Selvaraju, Michael Cogswell, Abhishek Das, Ramakrishna Vedantam, Devi Parikh, and Dhruv Batra. Grad-cam: Visual explanations from deep networks via gradient-based localization. In *Proceedings of the IEEE international conference on computer vision*, pages 618–626, 2017.
770. Aditya Chattopadhyay, Anirban Sarkar, Prantik Howlader, and Vineeth N Balasubramanian. Grad-cam++: Generalized gradient-based visual explanations for deep convolutional networks. In *2018 IEEE winter conference on applications of computer vision (WACV)*, pages 839–847. IEEE, 2018.
771. Pieter-Jan Kindermans, Kristof T Schütt, Maximilian Alber, Klaus-Robert Müller, Dumitru Erhan, Been Kim, and Sven Dähne. Learning how to explain neural networks: Patternnet and patternattribution. *arXiv preprint arXiv:1705.05598*, 2017.
772. Sebastian Bach, Alexander Binder, Grégoire Montavon, Frederick Klauschen, Klaus-Robert Müller, and Wojciech Samek. On pixel-wise explanations for non-linear classifier decisions by layer-wise relevance propagation. *PloS one*, 10(7):e0130140, 2015.
773. Fan Yang, Mengnan Du, and Xia Hu. Evaluating explanation without ground truth in interpretable machine learning. *arXiv preprint arXiv:1907.06831*, 2019.
774. Huiqi Deng, Na Zou, Mengnan Du, Weifu Chen, Guocan Feng, and Xia Hu. A general taylor framework for unifying and revisiting attribution methods. *arXiv preprint arXiv:2105.13841*, 2021.
775. Marco Ancona, Enea Ceolini, Cengiz Öztireli, and Markus Gross. Towards better understanding of gradient-based attribution methods for deep neural networks. In *International Conference on Learning Representations*, 2018.
776. Xu Cheng, Zhefan Rao, Yilan Chen, and Quanshi Zhang. Explaining knowledge distillation by quantifying the knowledge. In *Proceedings of the IEEE/CVF Conference on Computer Vision and Pattern Recognition*, pages 12925–12935, 2020.
777. Mingjie Li, Shaobo Wang, and Quanshi Zhang. Visualizing the emergence of intermediate visual patterns in dnns. In *Thirty-Fifth Conference on Neural Information Processing Systems*, 2021.
778. Jie Ren, Mingjie Li, Zexu Liu, and Quanshi Zhang. Interpreting and disentangling feature components of various complexity from dnns. In *International Conference on Machine Learning*, pages 8971–8981. PMLR, 2021.
779. Hao Zhang, Sen Li, YinChao Ma, Mingjie Li, Yichen Xie, and Quanshi Zhang. Interpreting and boosting dropout from a game-theoretic view. In *International Conference on Learning Representations*, 2020.
780. Jie Ren, Die Zhang, Yisen Wang, Lu Chen, Zhanpeng Zhou, Yiting Chen, Xu Cheng, Xin Wang, Meng Zhou, Jie Shi, et al. Towards a unified game-theoretic view of adversarial perturbations and robustness. *Advances in Neural Information Processing Systems*, 34, 2021.

781. Maithra Raghu, Justin Gilmer, Jason Yosinski, and Jascha Sohl-Dickstein. Svcca: Singular vector canonical correlation analysis for deep learning dynamics and interpretability. *arXiv preprint arXiv:1706.05806*, 2017.
782. Ruofan Liang, Tianlin Li, Longfei Li, Jing Wang, and Quanshi Zhang. Knowledge consistency between neural networks and beyond. In *International Conference on Learning Representations*, 2019.
783. Ian J Goodfellow, Jonathon Shlens, and Christian Szegedy. Explaining and harnessing adversarial examples. *arXiv preprint arXiv:1412.6572*, 2014.
784. Andrew Ilyas, Shibani Santurkar, Dimitris Tsipras, Logan Engstrom, Brandon Tran, and Aleksander Madry. Adversarial examples are not bugs, they are features. *arXiv preprint arXiv:1905.02175*, 2019.
785. Dimitris Tsipras, Shibani Santurkar, Logan Engstrom, Alexander Turner, and Aleksander Madry. Robustness may be at odds with accuracy. *arXiv preprint arXiv:1805.12152*, 2018.
786. Christian Szegedy, Wojciech Zaremba, Ilya Sutskever, Joan Bruna, Dumitru Erhan, Ian Goodfellow, and Rob Fergus. Intriguing properties of neural networks. *arXiv preprint arXiv:1312.6199*, 2013.
787. Matthias Hein and Maksym Andriushchenko. Formal guarantees on the robustness of a classifier against adversarial manipulation. *arXiv preprint arXiv:1705.08475*, 2017.
788. Alhussein Fawzi, Omar Fawzi, and Pascal Frossard. Analysis of classifiers’ robustness to adversarial perturbations. *Machine Learning*, 107(3):481–508, 2018.
789. Tsui-Wei Weng, Huan Zhang, Pin-Yu Chen, Jinfeng Yi, Dong Su, Yupeng Gao, Cho-Jui Hsieh, and Luca Daniel. Evaluating the robustness of neural networks: An extreme value theory approach. *arXiv preprint arXiv:1801.10578*, 2018.
790. Ambar Pal and Rene Vidal. A game theoretic analysis of additive adversarial attacks and defenses. *Advances in Neural Information Processing Systems*, 33, 2020.
791. Peter L Bartlett. The sample complexity of pattern classification with neural networks: the size of the weights is more important than the size of the network. *IEEE transactions on Information Theory*, 44(2):525–536, 1998.
792. Behnam Neyshabur, Srinadh Bhojanapalli, David McAllester, and Nathan Srebro. Exploring generalization in deep learning. *arXiv preprint arXiv:1706.08947*, 2017.
793. Moritz Hardt, Ben Recht, and Yoram Singer. Train faster, generalize better: Stability of stochastic gradient descent. In *International Conference on Machine Learning*, pages 1225–1234. PMLR, 2016.
794. Chiyuan Zhang, Samy Bengio, Moritz Hardt, Benjamin Recht, and Oriol Vinyals. Understanding deep learning (still) requires rethinking generalization. *Communications of the ACM*, 64(3):107–115, 2021.
795. Stanislav Fort, Paweł Krzysztof Nowak, Stanislaw Jastrzebski, and Srini Narayanan. Stiffness: A new perspective on generalization in neural networks. *arXiv preprint arXiv:1901.09491*, 2019.
796. Zhiqin John Xu. Understanding training and generalization in deep learning by fourier analysis. *arXiv preprint arXiv:1808.04295*, 2018.
797. Roman Novak, Yasaman Bahri, Daniel A Abolafia, Jeffrey Pennington, and Jascha Sohl-Dickstein. Sensitivity and generalization in neural networks: an empirical study. *arXiv preprint arXiv:1802.08760*, 2018.
798. Jianyuan Guo, Kai Han, Han Wu, Chang Xu, Yehui Tang, Chunjing Xu, and Yunhe Wang. Cmt: Convolutional neural networks meet vision transformers. *arXiv preprint arXiv:2107.06263*, 2021.
799. Aravind Srinivas, Tsung-Yi Lin, Niki Parmar, Jonathon Shlens, Pieter Abbeel, and Ashish Vaswani. Bottleneck transformers for visual recognition. In *Proceedings of the IEEE/CVF Conference on Computer Vision and Pattern Recognition*, pages 16519–16529, 2021.
800. Maithra Raghu, Thomas Unterthiner, Simon Kornblith, Chiyuan Zhang, and Alexey Dosovitskiy. Do vision transformers see like convolutional neural networks? In *Thirty-Fifth Conference on Neural Information Processing Systems*, 2021.
801. Anonymous. How do vision transformers work? In *Submitted to The Tenth International Conference on Learning Representations*, 2022. under review.
802. Andrew M Saxe, Yamini Bansal, Joel Dapello, Madhu Advani, Artemy Kolchinsky, Brendan D Tracey, and David D Cox. On the information bottleneck theory of deep learning. *Journal of Statistical Mechanics: Theory and Experiment*, 2019(12):124020, 2019.
803. Huiqi Deng, Qihan Ren, Xu Chen, Hao Zhang, Jie Ren, and Quanshi Zhang. Discovering and explaining the representation bottleneck of dnns. *arXiv preprint arXiv:2111.06236*, 2021.
804. Robert Geirhos, Jörn-Henrik Jacobsen, Claudio Michaelis, Richard Zemel, Wieland Brendel, Matthias Bethge, and Felix A Wichmann. Shortcut learning in deep neural networks. *Nature Machine Intelligence*, 2(11):665–673, 2020.
805. Chenxi Liu, Barret Zoph, Maxim Neumann, Jonathon Shlens, Wei Hua, Li-Jia Li, Li Fei-Fei, Alan Yuille, Jonathan Huang, and Kevin Murphy. Progressive neural architecture search. In *Proceedings of the European conference on computer vision (ECCV)*, pages 19–34, 2018.
806. Hieu Pham, Melody Guan, Barret Zoph, Quoc Le, and Jeff Dean. Efficient neural architecture search via parameters sharing. In *International Conference on Machine Learning*, pages 4095–4104. PMLR, 2018.
807. Haifeng Jin, Qingquan Song, and Xia Hu. Auto-keras: An efficient neural architecture search system. In *Proceedings of the 25th ACM SIGKDD International Conference on Knowledge Discovery & Data Mining*, pages 1946–1956, 2019.
808. Maarten Sap, Vered Shwartz, Antoine Bosselut, Yejin Choi, and Dan Roth. Commonsense reasoning for natural language processing. In *Proceedings of the 58th Annual Meeting of the Association for Computational Linguistics: Tutorial Abstracts*, pages 27–33, Online, July 2020. Association for Computational Linguistics.
809. Jian Guan, Yansen Wang, and Minlie Huang. Story ending generation with incremental encoding and commonsense knowledge. In *AAAI*, pages 6473–6480, 2019.

810. Bill Yuchen Lin, Xinyue Chen, Jamin Chen, and Xiang Ren. Kagnet: Knowledge-aware graph networks for commonsense reasoning. In *Proceedings of the 2019 Conference on Empirical Methods in Natural Language Processing and the 9th International Joint Conference on Natural Language Processing, EMNLP-IJCNLP 2019, Hong Kong, China, November 3-7, 2019*, pages 2829–2839, 2019.
811. Lisa Bauer, Yicheng Wang, and Mohit Bansal. Commonsense for generative multi-hop question answering tasks. In *Proceedings of the 2018 Conference on Empirical Methods in Natural Language Processing, Brussels, Belgium, October 31 - November 4, 2018*, pages 4220–4230, 2018.
812. Hao Zhou, Tom Young, Minlie Huang, Haizhou Zhao, Jingfang Xu, and Xiaoyan Zhu. Commonsense knowledge aware conversation generation with graph attention. In *IJCAI*, pages 4623–4629, 2018.
813. Jiaao Chen, Jianshu Chen, and Zhou Yu. Incorporating structured commonsense knowledge in story completion. In *AAAI*, pages 6244–6251, 2019.
814. Debjit Paul and Anette Frank. Ranking and selecting multi-hop knowledge paths to better predict human needs. In *PNAACL-HLT*, pages 3671–3681, 2019.
815. Xiaoyan Wang, Pavan Kapanipathi, Ryan Musa, Mo Yu, Kartik Talamadupula, Ibrahim Abdelaziz, Maria Chang, Achille Fokoue, Bassem Makni, Nicholas Mattei, and Michael Witbrock. Improving natural language inference using external knowledge in the science questions domain. In *AAAI*, pages 7208–7215, 2019.
816. Nathaniel Weir, Adam Poliak, and Benjamin Van Durme. Probing neural language models for human tacit assumptions. In *Proceedings of the 42th Annual Meeting of the Cognitive Science Society - Developing a Mind: Learning in Humans, Animals, and Machines, CogSci 2020, virtual, July 29 - August 1, 2020*, 2020.
817. Ellen Prince. On the function of existential presupposition in discourse. *papers from regional meeting cls*, 1978.
818. Vered Shwartz, Peter West, Ronan Le Bras, Chandra Bhagavatula, and Yejin Choi. Unsupervised commonsense question answering with self-talk. In *Proceedings of the 2020 Conference on Empirical Methods in Natural Language Processing, EMNLP 2020, Online, November 16-20, 2020*, pages 4615–4629, 2020.
819. Rowan Zellers, Ari Holtzman, Yonatan Bisk, Ali Farhadi, and Yejin Choi. Hellaswag: Can a machine really finish your sentence? In *Proceedings of the 57th Conference of the Association for Computational Linguistics, ACL 2019, Florence, Italy, July 28- August 2, 2019, Volume 1: Long Papers*, pages 4791–4800, 2019.
820. Yonatan Bisk, Rowan Zellers, Ronan LeBras, Jianfeng Gao, and Yejin Choi. PIQA: reasoning about physical commonsense in natural language. In *AAAI*, pages 7432–7439, 2020.
821. Nora Kassner and Hinrich Schütze. Negated and misprimed probes for pretrained language models: Birds can talk, but cannot fly. In *ACL*, pages 7811–7818, 2020.
822. Alon Talmor, Yanai Elazar, Yoav Goldberg, and Jonathan Berant. olympics - on what language model pre-training captures. *Trans. Assoc. Comput. Linguistics*, 8:743–758, 2020.
823. Pratyay Banerjee, Kuntal Kumar Pal, Arindam Mitra, and Chitta Baral. Careful selection of knowledge to solve open book question answering. In *Proceedings of the 57th Conference of the Association for Computational Linguistics, ACL 2019, Florence, Italy, July 28- August 2, 2019, Volume 1: Long Papers*, pages 6120–6129, 2019.
824. Niket Tandon, Bhavana Dalvi, Joel Grus, Wen-tau Yih, Antoine Bosselut, and Peter Clark. Reasoning about actions and state changes by injecting commonsense knowledge. In *Proceedings of the 2018 Conference on Empirical Methods in Natural Language Processing, Brussels, Belgium, October 31 - November 4, 2018*, pages 57–66, 2018.
825. Hongyu Lin, Le Sun, and Xianpei Han. Reasoning with heterogeneous knowledge for commonsense machine comprehension. In *Proceedings of the 2017 Conference on Empirical Methods in Natural Language Processing, EMNLP 2017, Copenhagen, Denmark, September 9-11, 2017*, pages 2032–2043, 2017.
826. Qian Li, Ziwei Li, Jin-Mao Wei, Yanhui Gu, Adam Jatowt, and Zhenglu Yang. A multi-attention based neural network with external knowledge for story ending predicting task. In *Proceedings of the 27th International Conference on Computational Linguistics, COLING 2018, Santa Fe, New Mexico, USA, August 20-26, 2018*, pages 1754–1762, 2018.
827. Nazneen Fatema Rajani, Bryan McCann, Caiming Xiong, and Richard Socher. Explain yourself! leveraging language models for commonsense reasoning. In *ACL*, pages 4932–4942, 2019.
828. Wanjun Zhong, Duyu Tang, Nan Duan, Ming Zhou, Jiahai Wang, and Jian Yin. Improving question answering by commonsense-based pre-training. In *NLPCC*, pages 16–28, 2019.
829. Shangwen Lv, Daya Guo, Jingjing Xu, Duyu Tang, Nan Duan, Ming Gong, Linjun Shou, Daxin Jiang, Guihong Cao, and Songlin Hu. Graph-based reasoning over heterogeneous external knowledge for commonsense question answering. In *AAAI*, pages 8449–8456, 2020.
830. Yanlin Feng, Xinyue Chen, Bill Yuchen Lin, Peifeng Wang, Jun Yan, and Xiang Ren. Scalable multi-hop relational reasoning for knowledge-aware question answering. In *EMNLP*, pages 1295–1309, 2020.
831. Michihiro Yasunaga, Hongyu Ren, Antoine Bosselut, Percy Liang, and Jure Leskovec. QA-GNN: reasoning with language models and knowledge graphs for question answering. In *Proceedings of the 2021 Conference of the North American Chapter of the Association for Computational Linguistics: Human Language Technologies, NAACL-HLT 2021, Online, June 6-11, 2021*, pages 535–546, 2021.
832. Anonymous. GreaseLM: Graph REASONing enhanced language models. In *ICLR*, 2022. under review.
833. Arthur Graesser, Murray Singer, and Tom Trabasso. Constructing inferences during narrative text comprehension. pages 371–95, 08 1994.
834. Martin Conway and Christopher Pleydell-Pearce. The construction of autobiographical memories in the self-memory system. *Psychological review*, 107:261–88, 05 2000.

835. Walter Kintsch. The role of knowledge in discourse comprehension: a construction-integration model. *Psychological review*, 95 2:163–82, 1988.
836. Jena D. Hwang, Chandra Bhagavatula, Ronan Le Bras, Jeff Da, Keisuke Sakaguchi, Antoine Bosselut, and Yejin Choi. (comet-) atomic 2020: On symbolic and neural commonsense knowledge graphs. In *Thirty-Fifth AAAI Conference on Artificial Intelligence, AAAI 2021, Thirty-Third Conference on Innovative Applications of Artificial Intelligence, IAAI 2021, The Eleventh Symposium on Educational Advances in Artificial Intelligence, EAAI 2021, Virtual Event, February 2-9, 2021*, pages 6384–6392, 2021.
837. Niket Tandon, Gerard de Melo, Fabian M. Suchanek, and Gerhard Weikum. Webchild: harvesting and organizing commonsense knowledge from the web. In *Seventh ACM International Conference on Web Search and Data Mining, WSDM 2014, New York, NY, USA, February 24-28, 2014*, pages 523–532, 2014.
838. Niket Tandon, Gerard de Melo, and Gerhard Weikum. Webchild 2.0 : Fine-grained commonsense knowledge distillation. In *Proceedings of the 55th Annual Meeting of the Association for Computational Linguistics, ACL 2017, Vancouver, Canada, July 30 - August 4, System Demonstrations*, pages 115–120, 2017.
839. Rowan Zellers, Yonatan Bisk, Roy Schwartz, and Yejin Choi. SWAG: A large-scale adversarial dataset for grounded commonsense inference. In *Proceedings of the 2018 Conference on Empirical Methods in Natural Language Processing, Brussels, Belgium, October 31 - November 4, 2018*, pages 93–104, 2018.
840. Sheng Zhang, Rachel Rudinger, Kevin Duh, and Benjamin Van Durme. Ordinal common-sense inference. *Trans. Assoc. Comput. Linguistics*, 5:379–395, 2017.
841. Chandra Bhagavatula, Ronan Le Bras, Chaitanya Malaviya, Keisuke Sakaguchi, Ari Holtzman, Hannah Rashkin, Doug Downey, Wen-tau Yih, and Yejin Choi. Abductive commonsense reasoning. In *8th International Conference on Learning Representations, Addis Ababa, Ethiopia, April 26-30, 2020*. OpenReview.net, 2020.
842. Alon Talmor, Jonathan Herzig, Nicholas Lourie, and Jonathan Berant. Commonsenseqa: A question answering challenge targeting commonsense knowledge. In *Proceedings of the 2019 Conference of the North American Chapter of the Association for Computational Linguistics: Human Language Technologies, NAACL-HLT 2019, Minneapolis, MN, USA, June 2-7, 2019, Volume 1 (Long and Short Papers)*, pages 4149–4158. Association for Computational Linguistics, 2019.
843. Maarten Sap, Hannah Rashkin, Derek Chen, Ronan Le Bras, and Yejin Choi. Social iqa: Commonsense reasoning about social interactions. In *Proceedings of the 2019 Conference on Empirical Methods in Natural Language Processing and the 9th International Joint Conference on Natural Language Processing, EMNLP-IJCNLP 2019, Hong Kong, China, November 3-7, 2019*, pages 4462–4472. Association for Computational Linguistics, 2019.
844. Nasrin Mostafazadeh, Nathanael Chambers, Xiaodong He, Devi Parikh, Dhruv Batra, Lucy Vanderwende, Pushmeet Kohli, and James F. Allen. A corpus and cloze evaluation for deeper understanding of commonsense stories. In *NAACL HLT 2016, The 2016 Conference of the North American Chapter of the Association for Computational Linguistics: Human Language Technologies, San Diego California, USA, June 12-17, 2016*, pages 839–849. The Association for Computational Linguistics, 2016.
845. Hannah Rashkin, Antoine Bosselut, Maarten Sap, Kevin Knight, and Yejin Choi. Modeling naive psychology of characters in simple commonsense stories. In *Proceedings of the 56th Annual Meeting of the Association for Computational Linguistics, ACL 2018, Melbourne, Australia, July 15-20, 2018, Volume 1: Long Papers*, pages 2289–2299. Association for Computational Linguistics, 2018.
846. Hector Levesque, Ernest Davis, and Leora Morgenstern. The winograd schema challenge. In *Thirteenth International Conference on the Principles of Knowledge Representation and Reasoning*. Citeseer, 2012.
847. Melissa Roemmele, Cosmin Adrian Bejan, and Andrew S. Gordon. Choice of plausible alternatives: An evaluation of commonsense causal reasoning. In *Logical Formalizations of Commonsense Reasoning, Papers from the 2011 AAAI Spring Symposium, Technical Report SS-11-06, Stanford, California, USA, March 21-23, 2011*. AAAI, 2011.
848. Rowan Zellers, Yonatan Bisk, Ali Farhadi, and Yejin Choi. From recognition to cognition: Visual commonsense reasoning. In *IEEE Conference on Computer Vision and Pattern Recognition, CVPR 2019, Long Beach, CA, USA, June 16-20, 2019*, pages 6720–6731. Computer Vision Foundation / IEEE, 2019.
849. Keisuke Sakaguchi, Ronan Le Bras, Chandra Bhagavatula, and Yejin Choi. Winogrande: An adversarial winograd schema challenge at scale. In *Proceedings of the AAAI Conference on Artificial Intelligence*, volume 34, pages 8732–8740, 2020.
850. Ben Zhou, Daniel Khashabi, Qiang Ning, and Dan Roth. "going on a vacation" takes longer than "going for a walk": A study of temporal commonsense understanding. In *Proceedings of the 2019 Conference on Empirical Methods in Natural Language Processing and the 9th International Joint Conference on Natural Language Processing, EMNLP-IJCNLP 2019, Hong Kong, China, November 3-7, 2019*, pages 3361–3367. Association for Computational Linguistics, 2019.
851. Sheng Zhang, Xiaodong Liu, Jingjing Liu, Jianfeng Gao, Kevin Duh, and Benjamin Van Durme. Record: Bridging the gap between human and machine commonsense reading comprehension. *arXiv preprint arXiv:1810.12885*, 2018.
852. Lifu Huang, Ronan Le Bras, Chandra Bhagavatula, and Yejin Choi. Cosmos QA: machine reading comprehension with contextual commonsense reasoning. In *Proceedings of the 2019 Conference on Empirical Methods in Natural Language Processing and the 9th International Joint Conference on Natural Language Processing, EMNLP-IJCNLP 2019, Hong Kong, China, November 3-7, 2019*, pages 2391–2401. Association for Computational Linguistics, 2019.
853. Daniel Khashabi, Snigdha Chaturvedi, Michael Roth, Shyam Upadhyay, and Dan Roth. Looking beyond the surface: A challenge set for reading comprehension over multiple sentences. In *Proceedings of the 2018 Conference of the North American Chapter of the Association for Computational Linguistics: Human Language Technologies, NAACL-HLT 2018, New Orleans, Louisiana, USA, June 1-6, 2018, Volume 1 (Long Papers)*, pages 252–262. Association for Computational Linguistics, 2018.

854. Yinquan Lu, Haonan Lu, Guirong Fu, and Qun Liu. KELM: knowledge enhanced pre-trained language representations with message passing on hierarchical relational graphs. *CoRR*, abs/2109.04223, 2021.
855. Ikuya Yamada, Akari Asai, Hiroyuki Shindo, Hideaki Takeda, and Yuji Matsumoto. LUKE: deep contextualized entity representations with entity-aware self-attention. In Bonnie Webber, Trevor Cohn, Yulan He, and Yang Liu, editors, *Proceedings of the 2020 Conference on Empirical Methods in Natural Language Processing, EMNLP 2020, Online, November 16-20, 2020*, pages 6442–6454. Association for Computational Linguistics, 2020.
856. Liang Yao, Chengsheng Mao, and Yuan Luo. KG-BERT: BERT for knowledge graph completion. *CoRR*, abs/1909.03193, 2019.
857. Ye Liu, Yao Wan, Lifang He, Hao Peng, and Philip S. Yu. KG-BART: knowledge graph-augmented BART for generative commonsense reasoning. In *Thirty-Fifth AAAI Conference on Artificial Intelligence, AAAI 2021, Thirty-Third Conference on Innovative Applications of Artificial Intelligence, IAAI 2021, The Eleventh Symposium on Educational Advances in Artificial Intelligence, EAAI 2021, Virtual Event, February 2-9, 2021*, pages 6418–6425. AAAI Press, 2021.
858. Jingyi Hou, Xinxiao Wu, Xiaoxun Zhang, Yayun Qi, Yunde Jia, and Jiebo Luo. Joint commonsense and relation reasoning for image and video captioning. In *The Thirty-Fourth AAAI Conference on Artificial Intelligence, AAAI 2020, The Thirty-Second Innovative Applications of Artificial Intelligence Conference, IAAI 2020, The Tenth AAAI Symposium on Educational Advances in Artificial Intelligence, EAAI 2020, New York, NY, USA, February 7-12, 2020*, pages 10973–10980. AAAI Press, 2020.
859. Ayodeji Oseni, Nour Moustafa, Helge Janicke, Peng Liu, Zahir Tari, and Athanasios Vasilakos. Security and privacy for artificial intelligence: Opportunities and challenges. *arXiv preprint arXiv:2102.04661*, 2021.
860. Nicolas Papernot, Patrick McDaniel, Somesh Jha, Matt Fredrikson, Z Berkay Celik, and Ananthram Swami. The limitations of deep learning in adversarial settings. In *2016 IEEE European symposium on security and privacy (EuroS&P)*, pages 372–387. IEEE, 2016.
861. Huaqing Lin, Zheng Yan, Yu Chen, and Lifang Zhang. A survey on network security-related data collection technologies. *IEEE Access*, 6:18345–18365, 2018.
862. Battista Biggio, Iginio Corona, Davide Maiorca, Blaine Nelson, Nedim Šrndić, Pavel Laskov, Giorgio Giacinto, and Fabio Roli. Evasion attacks against machine learning at test time. In *Joint European conference on machine learning and knowledge discovery in databases*, pages 387–402. Springer, 2013.
863. Dan Hendrycks, Nicholas Carlini, John Schulman, and Jacob Steinhardt. Unsolved problems in ml safety. *arXiv preprint arXiv:2109.13916*, 2021.
864. Nicholas Carlini, Anish Athalye, Nicolas Papernot, Wieland Brendel, Jonas Rauber, Dimitris Tsipras, Ian Goodfellow, Aleksander Madry, and Alexey Kurakin. On evaluating adversarial robustness. *arXiv preprint arXiv:1902.06705*, 2019.
865. Alexey Kurakin, Ian Goodfellow, and Samy Bengio. Adversarial examples in the physical world. In *The International Conference on Learning Representations (ICLR) Workshops*, 2017.
866. Aleksander Madry, Aleksandar Makelov, Ludwig Schmidt, Dimitris Tsipras, and Adrian Vladu. Towards deep learning models resistant to adversarial attacks. In *ICLR*, 2018.
867. Seyed-Mohsen Moosavi-Dezfooli, Alhussein Fawzi, and Pascal Frossard. Deepfool: a simple and accurate method to fool deep neural networks. In *IEEE Conference on Computer Vision and Pattern Recognition (CVPR)*, pages 2574–2582, 2016.
868. Nicholas Carlini and David Wagner. Towards evaluating the robustness of neural networks. In *2017 IEEE Symposium on Security and Privacy (SP)*, pages 39–57. IEEE, 2017.
869. Diederik P Kingma and Jimmy Ba. Adam: A method for stochastic optimization. In *ICLR*, 2015.
870. Anish Athalye, Nicholas Carlini, and David Wagner. Obfuscated gradients give a false sense of security: Circumventing defenses to adversarial examples. In *International Conference on Machine Learning (ICML)*, 2018.
871. Anish Athalye, Logan Engstrom, Andrew Ilyas, and Kevin Kwok. Synthesizing robust adversarial examples. In *International Conference on Machine Learning (ICML)*, 2018.
872. Xiao Yang, Yinpeng Dong, Tianyu Pang, Hang Su, and Jun Zhu. Boosting transferability of targeted adversarial examples via hierarchical generative networks. *arXiv preprint arXiv:2107.01809*, 2021.
873. Yinpeng Dong, Fangzhou Liao, Tianyu Pang, Hang Su, Jun Zhu, Xiaolin Hu, and Jianguo Li. Boosting adversarial attacks with momentum. In *IEEE Conference on Computer Vision and Pattern Recognition (CVPR)*, 2018.
874. Cihang Xie, Zhishuai Zhang, Yuyin Zhou, Song Bai, Jianyu Wang, Zhou Ren, and Alan L Yuille. Improving transferability of adversarial examples with input diversity. In *Proceedings of the IEEE Conference on Computer Vision and Pattern Recognition (CVPR)*, 2019.
875. Yinpeng Dong, Tianyu Pang, Hang Su, and Jun Zhu. Evading defenses to transferable adversarial examples by translation-invariant attacks. In *IEEE Conference on Computer Vision and Pattern Recognition (CVPR)*, 2019.
876. Pin-Yu Chen, Huan Zhang, Yash Sharma, Jinfeng Yi, and Cho-Jui Hsieh. Zoo: Zeroth order optimization based black-box attacks to deep neural networks without training substitute models. In *ACM Workshop on Artificial Intelligence and Security (AISec)*. ACM, 2017.
877. Andrew Ilyas, Logan Engstrom, Anish Athalye, and Jessy Lin. Black-box adversarial attacks with limited queries and information. In *International Conference on Machine Learning (ICML)*, 2018.
878. Jonathan Uesato, Brendan O’Donoghue, Aaron van den Oord, and Pushmeet Kohli. Adversarial risk and the dangers of evaluating against weak attacks. In *International Conference on Machine Learning (ICML)*, 2018.
879. Shuyu Cheng, Yinpeng Dong, Tianyu Pang, Hang Su, and Jun Zhu. Improving black-box adversarial attacks with a transfer-based prior. In *Advances in Neural Information Processing Systems (NeurIPS)*, 2019.



880. Yandong Li, Lijun Li, Liqiang Wang, Tong Zhang, and Boqing Gong. Nattack: Learning the distributions of adversarial examples for an improved black-box attack on deep neural networks. In *International Conference on Machine Learning (ICML)*, 2019.
881. Wieland Brendel, Jonas Rauber, and Matthias Bethge. Decision-based adversarial attacks: Reliable attacks against black-box machine learning models. In *International Conference on Learning Representations (ICLR)*, 2018.
882. Minhao Cheng, Thong Le, Pin-Yu Chen, Jinfeng Yi, Huan Zhang, and Cho-Jui Hsieh. Query-efficient hard-label black-box attack: An optimization-based approach. In *International Conference on Learning Representations (ICLR)*, 2019.
883. Yinpeng Dong, Hang Su, Baoyuan Wu, Zhifeng Li, Wei Liu, Tong Zhang, and Jun Zhu. Efficient decision-based black-box adversarial attacks on face recognition. In *Proceedings of the IEEE Conference on Computer Vision and Pattern Recognition (CVPR)*, 2019.
884. Hongyang Zhang, Yaodong Yu, Jiantao Jiao, Eric P Xing, Laurent El Ghaoui, and Michael I Jordan. Theoretically principled trade-off between robustness and accuracy. In *ICML*, 2019.
885. Alexey Kurakin, Ian Goodfellow, Samy Bengio, Yinpeng Dong, Fangzhou Liao, Ming Liang, Tianyu Pang, Jun Zhu, Xiaolin Hu, Cihang Xie, et al. Adversarial attacks and defences competition. *arXiv preprint arXiv:1804.00097*, 2018.
886. Wieland Brendel, Jonas Rauber, Alexey Kurakin, Nicolas Papernot, Behar Veliqi, Sharada P Mohanty, Florian Laurent, Marcel Salathé, Matthias Bethge, Yaodong Yu, et al. Adversarial vision challenge. In *The NeurIPS'18 Competition*, pages 129–153. Springer, 2020.
887. Yinpeng Dong, Qi-An Fu, Xiao Yang, Wenzhao Xiang, Tianyu Pang, Hang Su, Jun Zhu, Jiayu Tang, Yuefeng Chen, XiaoFeng Mao, et al. Adversarial attacks on ml defense models competition. *arXiv preprint arXiv:2110.08042*, 2021.
888. Yuefeng Chen, Xiaofeng Mao, Yuan He, Hui Xue, Chao Li, Yinpeng Dong, Qi-An Fu, Xiao Yang, Wenzhao Xiang, Tianyu Pang, et al. Unrestricted adversarial attacks on imagenet competition. *arXiv preprint arXiv:2110.09903*, 2021.
889. Florian Tramèr, Alexey Kurakin, Nicolas Papernot, Dan Boneh, and Patrick McDaniel. Ensemble adversarial training: Attacks and defenses. In *International Conference on Learning Representations (ICLR)*, 2018.
890. Tianyu Pang, Kun Xu, Chao Du, Ning Chen, and Jun Zhu. Improving adversarial robustness via promoting ensemble diversity. In *International Conference on Machine Learning (ICML)*, 2019.
891. Chengzhi Mao, Ziyuan Zhong, Junfeng Yang, Carl Vondrick, and Baishakhi Ray. Metric learning for adversarial robustness. In *Advances in Neural Information Processing Systems (NeurIPS)*, pages 478–489, 2019.
892. Pengcheng Li, Jinfeng Yi, Bowen Zhou, and Lijun Zhang. Improving the robustness of deep neural networks via adversarial training with triplet loss. In *International Joint Conference on Artificial Intelligence (IJCAI)*, 2019.
893. Tianyu Pang, Xiao Yang, Yinpeng Dong, Kun Xu, Hang Su, and Jun Zhu. Boosting adversarial training with hypersphere embedding. In *Advances in Neural Information Processing Systems (NeurIPS)*, 2020.
894. Tianyu Pang, Kun Xu, Yinpeng Dong, Chao Du, Ning Chen, and Jun Zhu. Rethinking softmax cross-entropy loss for adversarial robustness. In *International Conference on Learning Representations (ICLR)*, 2020.
895. Haoming Jiang, Zhehui Chen, Yuyang Shi, Bo Dai, and Tuo Zhao. Learning to defense by learning to attack. *arXiv preprint arXiv:1811.01213*, 2018.
896. Tianyu Pang, Chao Du, and Jun Zhu. Max-mahalanobis linear discriminant analysis networks. In *International Conference on Machine Learning (ICML)*, 2018.
897. Huaxia Wang and Chun-Nam Yu. A direct approach to robust deep learning using adversarial networks. In *International Conference on Learning Representations (ICLR)*, 2019.
898. Zhijie Deng, Yinpeng Dong, Tianyu Pang, Hang Su, and Jun Zhu. Adversarial distributional training for robust deep learning. *arXiv preprint arXiv:2002.05999*, 2020.
899. Dongxian Wu, Shu-Tao Xia, and Yisen Wang. Adversarial weight perturbation helps robust generalization. *Advances in Neural Information Processing Systems (NeurIPS)*, 33, 2020.
900. Yair Carmon, Aditi Raghunathan, Ludwig Schmidt, Percy Liang, and John C Duchi. Unlabeled data improves adversarial robustness. In *Advances in Neural Information Processing Systems (NeurIPS)*, 2019.
901. Jean-Baptiste Alayrac, Jonathan Uesato, Po-Sen Huang, Alhussein Fawzi, Robert Stanforth, and Pushmeet Kohli. Are labels required for improving adversarial robustness? In *Advances in Neural Information Processing Systems (NeurIPS)*, pages 12192–12202, 2019.
902. Runtian Zhai, Tianle Cai, Di He, Chen Dan, Kun He, John Hopcroft, and Liwei Wang. Adversarially robust generalization just requires more unlabeled data. *arXiv preprint arXiv:1906.00555*, 2019.
903. Dan Hendrycks, Kimin Lee, and Mantas Mazeika. Using pre-training can improve model robustness and uncertainty. In *International Conference on Machine Learning (ICML)*, 2019.
904. Kejiang Chen, Yuefeng Chen, Hang Zhou, Xiaofeng Mao, Yuhong Li, Yuan He, Hui Xue, Weiming Zhang, and Nenghai Yu. Self-supervised adversarial training. In *IEEE International Conference on Acoustics, Speech and Signal Processing (ICASSP)*, pages 2218–2222. IEEE, 2020.
905. Tianlong Chen, Sijia Liu, Shiyu Chang, Yu Cheng, Lisa Amini, and Zhangyang Wang. Adversarial robustness: From self-supervised pre-training to fine-tuning. In *Conference on Computer Vision and Pattern Recognition (CVPR)*, pages 699–708, 2020.
906. Muzammal Naseer, Salman Khan, Munawar Hayat, Fahad Shahbaz Khan, and Fatih Porikli. A self-supervised approach for adversarial robustness. In *Conference on Computer Vision and Pattern Recognition (CVPR)*, pages 262–271, 2020.
907. Ali Shafahi, Mahyar Najibi, Amin Ghiasi, Zheng Xu, John Dickerson, Christoph Studer, Larry S Davis, Gavin Taylor, and Tom Goldstein. Adversarial training for free! In *Advances in Neural Information Processing Systems (NeurIPS)*, 2019.

908. Dinghuai Zhang, Tianyuan Zhang, Yiping Lu, Zhanxing Zhu, and Bin Dong. You only propagate once: Accelerating adversarial training via maximal principle. In *Advances in Neural Information Processing Systems (NeurIPS)*, 2019.
909. Yisen Wang, Xingjun Ma, James Bailey, Jinfeng Yi, Bowen Zhou, and Quanquan Gu. On the convergence and robustness of adversarial training. In *International Conference on Machine Learning (ICML)*, pages 6586–6595, 2019.
910. Jingfeng Zhang, Xilie Xu, Bo Han, Gang Niu, Lizhen Cui, Masashi Sugiyama, and Mohan Kankanhalli. Attacks which do not kill training make adversarial learning stronger. In *International Conference on Machine Learning (ICML)*, 2020.
911. Eric Wong, Leslie Rice, and J. Zico Kolter. Fast is better than free: Revisiting adversarial training. In *International Conference on Learning Representations (ICLR)*, 2020.
912. Guanxiong Liu, Issa Khalil, and Abdallah Khreishah. Using single-step adversarial training to defend iterative adversarial examples. *arXiv preprint arXiv:2002.09632*, 2020.
913. S Vivek B and R Venkatesh Babu. Single-step adversarial training with dropout scheduling. In *IEEE Conference on Computer Vision and Pattern Recognition (CVPR)*, 2020.
914. Maksym Andriushchenko and Nicolas Flammarion. Understanding and improving fast adversarial training. In *Advances in neural information processing systems (NeurIPS)*, 2020.
915. Qintong Li, Piji Li, Zhumin Chen, and Zhaochun Ren. Towards empathetic dialogue generation over multi-type knowledge. *arXiv preprint arXiv:2009.09708*, 2020.
916. Yinpeng Dong, Ke Xu, Xiao Yang, Tianyu Pang, Zhijie Deng, Hang Su, and Jun Zhu. Exploring memorization in adversarial training. *arXiv preprint arXiv:2106.01606*, 2021.
917. Tianyu Pang, Xiao Yang, Yinpeng Dong, Hang Su, and Jun Zhu. Bag of tricks for adversarial training. In *International Conference on Learning Representations (ICLR)*, 2021.
918. Sven Gowal, Chongli Qin, Jonathan Uesato, Timothy Mann, and Pushmeet Kohli. Uncovering the limits of adversarial training against norm-bounded adversarial examples. *arXiv preprint arXiv:2010.03593*, 2020.
919. Sylvestre-Alvise Rebuffi, Sven Gowal, Dan A Calian, Florian Stimberg, Olivia Wiles, and Timothy Mann. Fixing data augmentation to improve adversarial robustness. *arXiv preprint arXiv:2103.01946*, 2021.
920. Krishnamurthy Dvijotham, Sven Gowal, Robert Stanforth, Relja Arandjelovic, Brendan O’Donoghue, Jonathan Uesato, and Pushmeet Kohli. Training verified learners with learned verifiers. *arXiv preprint arXiv:1805.10265*, 2018.
921. Krishnamurthy Dvijotham, Robert Stanforth, Sven Gowal, Timothy Mann, and Pushmeet Kohli. A dual approach to scalable verification of deep networks. In *Annual Conference on Uncertainty in Artificial Intelligence (UAI)*, 2018.
922. Eric Wong and Zico Kolter. Provable defenses against adversarial examples via the convex outer adversarial polytope. In *International Conference on Machine Learning (ICML)*, pages 5283–5292, 2018.
923. Tsui-Wei Weng, Huan Zhang, Hongge Chen, Zhao Song, Cho-Jui Hsieh, Duane Boning, Inderjit S Dhillon, and Luca Daniel. Towards fast computation of certified robustness for relu networks. In *International Conference on Machine Learning (ICML)*, 2018.
924. Jeremy M Cohen, Elan Rosenfeld, and J Zico Kolter. Certified adversarial robustness via randomized smoothing. In *International Conference on Machine Learning (ICML)*, 2019.
925. Avrim Blum, Travis Dick, Naren Manoj, and Hongyang Zhang. Random smoothing might be unable to certify  $l_\infty$  robustness for high-dimensional images. *Journal of Machine Learning Research*, 21:1–21, 2020.
926. Aounon Kumar, Alexander Levine, Tom Goldstein, and Soheil Feizi. Curse of dimensionality on randomized smoothing for certifiable robustness. In *International Conference on Machine Learning (ICML)*, pages 5458–5467. PMLR, 2020.
927. Greg Yang, Tony Duan, J Edward Hu, Hadi Salman, Ilya Razenshteyn, and Jerry Li. Randomized smoothing of all shapes and sizes. In *International Conference on Machine Learning (ICML)*, pages 10693–10705. PMLR, 2020.
928. Marc Fischer, Maximilian Baader, and Martin Vechev. Certified defense to image transformations via randomized smoothing. *arXiv preprint arXiv:2002.12463*, 2020.
929. Pedro Tabacof and Eduardo Valle. Exploring the space of adversarial images. In *2016 International Joint Conference on Neural Networks (IJCNN)*, pages 426–433. IEEE, 2016.
930. Tianyu Pang, Kun Xu, and Jun Zhu. Mixup inference: Better exploiting mixup to defend adversarial attacks. In *International Conference on Learning Representations (ICLR)*, 2020.
931. Chuan Guo, Mayank Rana, Moustapha Cisse, and Laurens Van Der Maaten. Countering adversarial images using input transformations. In *International Conference on Learning Representations (ICLR)*, 2018.
932. Cihang Xie, Jianyu Wang, Zhishuai Zhang, Zhou Ren, and Alan Yuille. Mitigating adversarial effects through randomization. In *International Conference on Learning Representations (ICLR)*, 2018.
933. Edward Raff, Jared Sylvester, Steven Forsyth, and Mark McLean. Barrage of random transforms for adversarially robust defense. In *Proceedings of the IEEE Conference on Computer Vision and Pattern Recognition (CVPR)*, pages 6528–6537, 2019.
934. Fangzhou Liao, Ming Liang, Yinpeng Dong, Tianyu Pang, Xiaolin Hu, and Jun Zhu. Defense against adversarial attacks using high-level representation guided denoiser. In *IEEE Conference on Computer Vision and Pattern Recognition (CVPR)*, 2018.
935. Kathrin Grosse, Praveen Manoharan, Nicolas Papernot, Michael Backes, and Patrick McDaniel. On the (statistical) detection of adversarial examples. *arXiv preprint arXiv:1702.06280*, 2017.
936. Xuanqing Liu, Yao Li, Chongruo Wu, and Cho-Jui Hsieh. Adv-bnn: Improved adversarial defense through robust bayesian neural network. In *International Conference on Learning Representations (ICLR)*, 2019.
937. Jiajun Lu, Theerasit Issaranon, and David Forsyth. Safetynet: Detecting and rejecting adversarial examples robustly. In *International Conference on Computer Vision (ICCV)*, pages 446–454, 2017.

938. Jan Hendrik Metzen, Tim Genewein, Volker Fischer, and Bastian Bischoff. On detecting adversarial perturbations. In *International Conference on Learning Representations (ICLR)*, 2017.
939. Kevin Roth, Yannic Kilcher, and Thomas Hofmann. The odds are odd: A statistical test for detecting adversarial examples. In *International Conference on Machine Learning (ICML)*, 2019.
940. Chiliang Zhang, Zuoqiang Ye, Yan Wang, and Zhimou Yang. Detecting adversarial perturbations with saliency. In *2018 IEEE 3rd International Conference on Signal and Image Processing (ICSIP)*, pages 271–275. IEEE, 2018.
941. Lovedeep Gondara. Detecting adversarial samples using density ratio estimates. *arXiv preprint arXiv:1705.02224*, 2017.
942. Reuben Feinman, Ryan R Curtin, Saurabh Shintre, and Andrew B Gardner. Detecting adversarial samples from artifacts. *arXiv preprint arXiv:1703.00410*, 2017.
943. Tianyu Pang, Chao Du, Yinpeng Dong, and Jun Zhu. Towards robust detection of adversarial examples. In *Advances in Neural Information Processing Systems (NeurIPS)*, pages 4579–4589, 2018.
944. Weilin Xu, David Evans, and Yanjun Qi. Feature squeezing: Detecting adversarial examples in deep neural networks. *arXiv preprint arXiv:1704.01155*, 2017.
945. Fatemeh Sheikholeslami, Swayambhoo Jain, and Georgios B Giannakis. Minimum uncertainty based detection of adversaries in deep neural networks. *arXiv preprint arXiv:1904.02841*, 2019.
946. Chenxiao Zhao, P Thomas Fletcher, Mixue Yu, Yaxin Peng, Guixu Zhang, and Chaomin Shen. The adversarial attack and detection under the fisher information metric. In *Proceedings of the AAAI Conference on Artificial Intelligence*, volume 33, pages 5869–5876, 2019.
947. Xingjun Ma, Bo Li, Yisen Wang, Sarah M Erfani, Sudanthi Wijewickrema, Michael E Houle, Grant Schoenebeck, Dawn Song, and James Bailey. Characterizing adversarial subspaces using local intrinsic dimensionality. *arXiv preprint arXiv:1801.02613*, 2018.
948. Guanhong Tao, Shiqing Ma, Yingqi Liu, and Xiangyu Zhang. Attacks meet interpretability: Attribute-steered detection of adversarial samples. In *Advances in Neural Information Processing Systems (NeurIPS)*, pages 7717–7728, 2018.
949. Fabio Carrara, Rudy Becarelli, Roberto Caldelli, Fabrizio Falchi, and Giuseppe Amato. Adversarial examples detection in features distance spaces. In *Proceedings of the European Conference on Computer Vision (ECCV)*, 2018.
950. Tianyu Pang, Huishuai Zhang, Di He, Yinpeng Dong, Hang Su, Wei Chen, Jun Zhu, and Tie-Yan Liu. Adversarial training with rectified rejection. *arXiv preprint arXiv:2105.14785*, 2021.
951. Kimin Lee, Kibok Lee, Honglak Lee, and Jinwoo Shin. A simple unified framework for detecting out-of-distribution samples and adversarial attacks. In *Advances in Neural Information Processing Systems (NeurIPS)*, 2018.
952. Pouya Samangouei, Maya Kabkab, and Rama Chellappa. Defense-gan: Protecting classifiers against adversarial attacks using generative models. In *International Conference on Learning Representations (ICLR)*, 2018.
953. Yinpeng Dong, Qi-An Fu, Xiao Yang, Tianyu Pang, Hang Su, Zihao Xiao, and Jun Zhu. Benchmarking adversarial robustness on image classification. In *IEEE Conference on Computer Vision and Pattern Recognition (CVPR)*, 2020.
954. Francesco Croce and Matthias Hein. Reliable evaluation of adversarial robustness with an ensemble of diverse parameter-free attacks. In *International Conference on Machine Learning (ICML)*, 2020.
955. Xiao Yang, Yinpeng Dong, Wenzhao Xiang, Tianyu Pang, Hang Su, and Jun Zhu. Model-agnostic meta-attack: Towards reliable evaluation of adversarial robustness. *arXiv preprint arXiv:2110.08256*, 2021.
956. Jinghui Chen and Quanquan Gu. Rays: A ray searching method for hard-label adversarial attack. *arXiv preprint arXiv:2006.12792*, 2020.
957. Norman Mu and Justin Gilmer. Mnist-c: A robustness benchmark for computer vision. *arXiv preprint arXiv:1906.02337*, 2019.
958. Dan Hendrycks and Thomas Dietterich. Benchmarking neural network robustness to common corruptions and perturbations. In *International Conference on Learning Representations (ICLR)*, 2019.
959. Logan Engstrom, Brandon Tran, Dimitris Tsipras, Ludwig Schmidt, and Aleksander Madry. A rotation and a translation suffice: Fooling cnns with simple transformations. In *International Conference on Machine Learning (ICML)*, 2019.
960. Florian Tramèr and Dan Boneh. Adversarial training and robustness for multiple perturbations. In *Advances in Neural Information Processing Systems (NeurIPS)*, pages 5858–5868, 2019.
961. Francesco Croce, Maksym Andriushchenko, Vikash Sehwal, Edoardo Debenedetti, Nicolas Flammarion, Mung Chiang, Prateek Mittal, and Matthias Hein. Robustbench: a standardized adversarial robustness benchmark. *arXiv preprint arXiv:2010.09670*, 2020.
962. Lichao Sun, Kazuma Hashimoto, Wenpeng Yin, Akari Asai, Jia Li, Philip Yu, and Caiming Xiong. Adv-bert: Bert is not robust on misspellings! generating nature adversarial samples on bert. *arXiv preprint arXiv:2003.04985*, 2020.
963. Yankun Ren, Jianbin Lin, Siliang Tang, Jun Zhou, Shuang Yang, Yuan Qi, and Xiang Ren. Generating natural language adversarial examples on a large scale with generative models. *arXiv preprint arXiv:2003.10388*, 2020.
964. Chen Zhu, Yu Cheng, Zhe Gan, Siqi Sun, Thomas Goldstein, and Jingjing Liu. Freelb: Enhanced adversarial training for language understanding. In *International Conference on Learning Representations (ICLR)*, 2020.
965. Zhe Gan, Yen-Chun Chen, Linjie Li, Chen Zhu, Yu Cheng, and Jingjing Liu. Large-scale adversarial training for vision-and-language representation learning. *arXiv preprint arXiv:2006.06195*, 2020.
966. Xiaodong Liu, Hao Cheng, Pengcheng He, Weizhu Chen, Yu Wang, Hoifung Poon, and Jianfeng Gao. Adversarial training for large neural language models. *arXiv preprint arXiv:2004.08994*, 2020.
967. Boxin Wang, Shuhang Wang, Yu Cheng, Zhe Gan, Ruoxi Jia, Bo Li, and Jingjing Liu. Infobert: Improving robustness of language models from an information theoretic perspective. *arXiv preprint arXiv:2010.02329*, 2020.

968. Lijie Fan, Sijia Liu, Pin-Yu Chen, Gaoyuan Zhang, and Chuang Gan. When does contrastive learning preserve adversarial robustness from pretraining to finetuning? *Advances in Neural Information Processing Systems (NeurIPS)*, 34, 2021.
969. Zhao Meng, Yihan Dong, Mrinmaya Sachan, and Roger Wattenhofer. Self-supervised contrastive learning with adversarial perturbations for robust pretrained language models. *arXiv preprint arXiv:2107.07610*, 2021.
970. Gunnar Mein, Kevin Hartman, and Andrew Morris. Firebert: Hardening bert-based classifiers against adversarial attack. *arXiv preprint arXiv:2008.04203*, 2020.
971. Eric Lehman, Sarthak Jain, Karl Pichotta, Yoav Goldberg, and Byron C Wallace. Does bert pretrained on clinical notes reveal sensitive data? *arXiv preprint arXiv:2104.07762*, 2021.
972. Sayak Paul and Pin-Yu Chen. Vision transformers are robust learners. *arXiv preprint arXiv:2105.07581*, 2021.
973. Rulin Shao, Zhouxing Shi, Jinfeng Yi, Pin-Yu Chen, and Cho-Jui Hsieh. On the adversarial robustness of visual transformers. *arXiv preprint arXiv:2103.15670*, 2021.
974. Jindong Gu, Volker Tresp, and Yao Qin. Are vision transformers robust to patch perturbations? *arXiv preprint arXiv:2111.10659*, 2021.
975. Philipp Benz, Soomin Ham, Chaoning Zhang, Adil Karjauv, and In So Kweon. Adversarial robustness comparison of vision transformer and mlp-mixer to cnns. *arXiv preprint arXiv:2110.02797*, 2021.
976. Ahmed Aldahdooh, Wassim Hamidouche, and Olivier Deforges. Reveal of vision transformers robustness against adversarial attacks. *arXiv preprint arXiv:2106.03734*, 2021.
977. Yutong Bai, Jieru Mei, Alan Yuille, and Cihang Xie. Are transformers more robust than cnns? In *Thirty-Fifth Conference on Neural Information Processing Systems*, 2021.
978. Kaleel Mahmood, Rigel Mahmood, and Marten Van Dijk. On the robustness of vision transformers to adversarial examples. *arXiv preprint arXiv:2104.02610*, 2021.
979. Muzammal Naseer, Kanchana Ranasinghe, Salman Khan, Fahad Shahbaz Khan, and Fatih Porikli. On improving adversarial transferability of vision transformers. *arXiv preprint arXiv:2106.04169*, 2021.
980. Zhipeng Wei, Jingjing Chen, Micah Goldblum, Zuxuan Wu, Tom Goldstein, and Yu-Gang Jiang. Towards transferable adversarial attacks on vision transformers. *arXiv preprint arXiv:2109.04176*, 2021.
981. Divya Choudhary, Palash Goyal, and Saurabh Sahu. Can't fool me: Adversarially robust transformer for video understanding. *arXiv preprint arXiv:2110.13950*, 2021.
982. Yao Qin, Chiyuan Zhang, Ting Chen, Balaji Lakshminarayanan, Alex Beutel, and Xuezi Wang. Understanding and improving robustness of vision transformers through patch-based negative augmentation. *arXiv preprint arXiv:2110.07858*, 2021.
983. Hadi Salman, Saachi Jain, Eric Wong, and Aleksander Madry. Certified patch robustness via smoothed vision transformers. *arXiv preprint arXiv:2110.07719*, 2021.
984. Xiaofeng Mao, Gege Qi, Yuefeng Chen, Xiaodan Li, Ranjie Duan, Shaokai Ye, Yuan He, and Hui Xue. Towards robust vision transformer. *arXiv preprint arXiv:2105.07926*, 2021.
985. Cihang Xie, Mingxing Tan, Boqing Gong, Jiang Wang, Alan L Yuille, and Quoc V Le. Adversarial examples improve image recognition. In *Proceedings of the IEEE/CVF Conference on Computer Vision and Pattern Recognition*, pages 819–828, 2020.
986. Hadi Salman, Andrew Ilyas, Logan Engstrom, Ashish Kapoor, and Aleksander Madry. Do adversarially robust imagenet models transfer better? *arXiv preprint arXiv:2007.08489*, 2020.
987. Ziqing Yang, Yiming Cui, Wanxiang Che, Ting Liu, Shijin Wang, and Guoping Hu. Improving machine reading comprehension via adversarial training. *arXiv preprint arXiv:1911.03614*, 2019.
988. Xiao Yang, Yinpeng Dong, Tianyu Pang, Hang Su, Jun Zhu, Yuefeng Chen, and Hui Xue. Towards face encryption by generating adversarial identity masks. In *Proceedings of the IEEE/CVF International Conference on Computer Vision*, pages 3897–3907, 2021.
989. Aapo Hyvärinen. Estimation of non-normalized statistical models by score matching. *Journal of Machine Learning Research (JMLR)*, 6(Apr):695–709, 2005.
990. Yang Song, Sahaj Garg, Jiaxin Shi, and Stefano Ermon. Sliced score matching: A scalable approach to density and score estimation. In *Conference on Uncertainty in Artificial Intelligence (UAI)*, 2019.
991. Tianyu Pang, Kun Xu, Chongxuan Li, Yang Song, Stefano Ermon, and Jun Zhu. Efficient learning of generative models via finite-difference score matching. In *Advances in Neural Information Processing Systems (NeurIPS)*, 2020.
992. Pascal Vincent. A connection between score matching and denoising autoencoders. *Neural computation*, 23(7):1661–1674, 2011.
993. Erik Nijkamp, Mitch Hill, Tian Han, Song-Chun Zhu, and Ying Nian Wu. On the anatomy of mcmc-based maximum likelihood learning of energy-based models. *arXiv preprint arXiv:1903.12370*, 2019.
994. Erik Nijkamp, Song-Chun Zhu, and Ying Nian Wu. On learning non-convergent short-run mcmc toward energy-based model. *arXiv preprint arXiv:1904.09770*, 2019.
995. Battista Biggio, Blaine Nelson, and Pavel Laskov. Poisoning attacks against support vector machines. In *Proceedings of the 29th International Conference on Machine Learning*, pages 1467–1474, 2012.
996. Ram Shankar Siva Kumar, Magnus Nyström, John Lambert, Andrew Marshall, Mario Goertzel, Andi Comisssoneru, Matt Swann, and Sharon Xia. Adversarial machine learning—industry perspectives. *arXiv preprint arXiv:2002.05646*, 2020.
997. Pang Wei Koh and Percy Liang. Understanding black-box predictions via influence functions. In *International Conference on Machine Learning (ICML)*, pages 1885–1894. PMLR, 2017.

998. Bo Li, Yining Wang, Aarti Singh, and Yevgeniy Vorobeychik. Data poisoning attacks on factorization-based collaborative filtering. In *Advances in Neural Information Processing Systems (NeurIPS)*, 2016.
999. Tianyu Pang, Xiao Yang, Yinpeng Dong, Hang Su, and Jun Zhu. Accumulative poisoning attacks on real-time data. *arXiv preprint arXiv:2106.09993*, 2021.
1000. Ali Shafahi, W Ronny Huang, Mahyar Najibi, Octavian Suci, Christoph Studer, Tudor Dumitras, and Tom Goldstein. Poison frogs! targeted clean-label poisoning attacks on neural networks. In *Advances in Neural Information Processing Systems (NeurIPS)*, 2018.
1001. Chen Zhu, W Ronny Huang, Hengduo Li, Gavin Taylor, Christoph Studer, and Tom Goldstein. Transferable clean-label poisoning attacks on deep neural nets. In *International Conference on Machine Learning (ICML)*. PMLR, 2019.
1002. Hojjat Aghakhani, Dongyu Meng, Yu-Xiang Wang, Christopher Kruegel, and Giovanni Vigna. Bullseye polytope: A scalable clean-label poisoning attack with improved transferability. In *IEEE European Symposium on Security and Privacy*, 2021.
1003. Huang Xiao, Battista Biggio, Gavin Brown, Giorgio Fumera, Claudia Eckert, and Fabio Roli. Is feature selection secure against training data poisoning? In *International Conference on Machine Learning (ICML)*, pages 1689–1698, 2015.
1004. Luis Muñoz-González, Battista Biggio, Ambra Demontis, Andrea Paudice, Vasin Wongrassamee, Emil C Lupu, and Fabio Roli. Towards poisoning of deep learning algorithms with back-gradient optimization. In *Proceedings of the 10th ACM Workshop on Artificial Intelligence and Security*, pages 27–38, 2017.
1005. Chaofei Yang, Qing Wu, Hai Li, and Yiran Chen. Generative poisoning attack method against neural networks. *arXiv preprint arXiv:1703.01340*, 2017.
1006. Luis Muñoz-González, Bjarne Pfizner, Matteo Russo, Javier Carnerero-Cano, and Emil C Lupu. Poisoning attacks with generative adversarial nets. *arXiv preprint arXiv:1906.07773*, 2019.
1007. Yizhen Wang and Kamalika Chaudhuri. Data poisoning attacks against online learning. *arXiv preprint arXiv:1808.08994*, 2018.
1008. Xuezhou Zhang, Xiaojin Zhu, and Laurent Lessard. Online data poisoning attacks. In *Learning for Dynamics and Control*, pages 201–210. PMLR, 2020.
1009. Tianyu Gu, Brendan Dolan-Gavitt, and Siddharth Garg. Badnets: Identifying vulnerabilities in the machine learning model supply chain. *arXiv preprint arXiv:1708.06733*, 2017.
1010. Xinyun Chen, Chang Liu, Bo Li, Kimberly Lu, and Dawn Song. Targeted backdoor attacks on deep learning systems using data poisoning. *arXiv preprint arXiv:1712.05526*, 2017.
1011. Yingqi Liu, Shiqing Ma, Yousra Aafer, Wen-Chuan Lee, Juan Zhai, Weihang Wang, and Xiangyu Zhang. Trojaning attack on neural networks. In *Proceedings of the 25th Network and Distributed System Security Symposium (NDSS)*, 2018.
1012. Yuezun Li, Yiming Li, Baoyuan Wu, Longkang Li, Ran He, and Siwei Lyu. Invisible backdoor attack with sample-specific triggers. In *Proceedings of the IEEE/CVF International Conference on Computer Vision*, pages 16463–16472, 2021.
1013. Jie Zhang, Dongdong Chen, Jing Liao, Qidong Huang, Gang Hua, Weiming Zhang, and Nenghai Yu. Poison ink: Robust and invisible backdoor attack. *arXiv preprint arXiv:2108.02488*, 2021.
1014. Alexander Turner, Dimitris Tsipras, and Aleksander Madry. Label-consistent backdoor attacks. *arXiv preprint arXiv:1912.02771*, 2019.
1015. Emily Wenger, Josephine Passananti, Yuanshun Yao, Haitao Zheng, and Ben Y Zhao. Backdoor attacks on facial recognition in the physical world. *arXiv e-prints*, pages arXiv–2006, 2020.
1016. Xinyang Zhang, Zheng Zhang, Shouling Ji, and Ting Wang. Trojaning language models for fun and profit. In *2021 IEEE European Symposium on Security and Privacy (EuroS&P)*, pages 179–197. IEEE Computer Society, 2021.
1017. Lun Wang, Zaynah Javed, Xian Wu, Wenbo Guo, Xinyu Xing, and Dawn Song. Backdoor!: Backdoor attack against competitive reinforcement learning. *arXiv preprint arXiv:2105.00579*, 2021.
1018. Tongqing Zhai, Yiming Li, Ziqi Zhang, Baoyuan Wu, Yong Jiang, and Shu-Tao Xia. Backdoor attack against speaker verification. In *ICASSP 2021-2021 IEEE International Conference on Acoustics, Speech and Signal Processing (ICASSP)*, pages 2560–2564. IEEE, 2021.
1019. Brandon Tran, Jerry Li, and Aleksander Madry. Spectral signatures in backdoor attacks. In *Advances in Neural Information Processing Systems (NeurIPS)*, pages 8000–8010, 2018.
1020. Bryant Chen, Wilka Carvalho, Nathalie Baracaldo, Heiko Ludwig, Benjamin Edwards, Taesung Lee, Ian Molloy, and Biplav Srivastava. Detecting backdoor attacks on deep neural networks by activation clustering. *arXiv preprint arXiv:1811.03728*, 2018.
1021. Yansong Gao, Change Xu, Derui Wang, Shiping Chen, Damith C Ranasinghe, and Surya Nepal. Strip: A defence against trojan attacks on deep neural networks. In *Proceedings of the 35th Annual Computer Security Applications Conference (ACSAC)*, pages 113–125, 2019.
1022. Bolun Wang, Yuanshun Yao, Shawn Shan, Huiying Li, Bimal Viswanath, Haitao Zheng, and Ben Y Zhao. Neural cleanse: Identifying and mitigating backdoor attacks in neural networks. In *2019 IEEE Symposium on Security and Privacy (SP)*, pages 707–723. IEEE, 2019.
1023. Wenbo Guo, Lun Wang, Xinyu Xing, Min Du, and Dawn Song. Tabor: A highly accurate approach to inspecting and restoring trojan backdoors in ai systems. *arXiv preprint arXiv:1908.01763*, 2019.
1024. HariPriya Harikumar, Vuong Le, Santu Rana, Sourangshu Bhattacharya, Sunil Gupta, and Svetha Venkatesh. Scalable backdoor detection in neural networks. *arXiv preprint arXiv:2006.05646*, 2020.
1025. Ximing Qiao, Yukun Yang, and Hai Li. Defending neural backdoors via generative distribution modeling. In *Advances in Neural Information Processing Systems (NeurIPS)*, pages 14004–14013, 2019.

1026. Yinpeng Dong, Xiao Yang, Zhijie Deng, Tianyu Pang, Zihao Xiao, Hang Su, and Jun Zhu. Black-box detection of backdoor attacks with limited information and data. *arXiv preprint arXiv:2103.13127*, 2021.
1027. Soheil Kolouri, Aniruddha Saha, Hamed Pirsiavash, and Heiko Hoffmann. Universal litmus patterns: Revealing backdoor attacks in cnns. In *Proceedings of the IEEE/CVF Conference on Computer Vision and Pattern Recognition*, pages 301–310, 2020.
1028. Yuntao Liu, Yang Xie, and Ankur Srivastava. Neural trojans. In *IEEE International Conference on Computer Design (ICCD)*, pages 45–48. IEEE, 2017.
1029. B Gia Doan, Ehsan Abbasnejad, and Damith C Ranasinghe. Februus: Input purification defense against trojan attacks on deep neural network systems. *arXiv preprint arXiv:1908.03369*, 2019.
1030. Yiming Li, Tongqing Zhai, Baoyuan Wu, Yong Jiang, Zhifeng Li, and Shutao Xia. Rethinking the trigger of backdoor attack. *arXiv preprint arXiv:2004.04692*, 2020.
1031. Elan Rosenfeld, Ezra Winston, Pradeep Ravikumar, and Zico Kolter. Certified robustness to label-flipping attacks via randomized smoothing. In *International Conference on Machine Learning*, pages 8230–8241. PMLR, 2020.
1032. Binghui Wang, Xiaoyu Cao, Neil Zhenqiang Gong, et al. On certifying robustness against backdoor attacks via randomized smoothing. *arXiv preprint arXiv:2002.11750*, 2020.
1033. Jinyuan Jia, Yupei Liu, and Neil Zhenqiang Gong. Badencoder: Backdoor attacks to pre-trained encoders in self-supervised learning. *arXiv preprint arXiv:2108.00352*, 2021.
1034. Nicholas Carlini and Andreas Terzis. Poisoning and backdooring contrastive learning. *arXiv preprint arXiv:2106.09667*, 2021.
1035. Lujia Shen, Shouling Ji, Xuhong Zhang, Jinfeng Li, Jing Chen, Jie Shi, Chengfang Fang, Jianwei Yin, and Ting Wang. Backdoor pre-trained models can transfer to all. In *Proceedings of the 2021 ACM SIGSAC Conference on Computer and Communications Security*, pages 3141–3158, 2021.
1036. Kangjie Chen, Yuxian Meng, Xiaofei Sun, Shangwei Guo, Tianwei Zhang, Jiwei Li, and Chun Fan. Badpre: Task-agnostic backdoor attacks to pre-trained nlp foundation models. *arXiv preprint arXiv:2110.02467*, 2021.
1037. Keita Kurita, Paul Michel, and Graham Neubig. Weight poisoning attacks on pretrained models. In *Proceedings of the 58th Annual Meeting of the Association for Computational Linguistics*, pages 2793–2806, 2020.
1038. D Conor Seyle and Matthew Wilburn King. Understanding governance. In *State of the World 2014*, pages 20–28. Springer, 2014.
1039. John M Bryson, Barbara C Crosby, and Laura Bloomberg. Public value governance: Moving beyond traditional public administration and the new public management, 2014.
1040. Ryan Calo and Danielle Keats Citron. The automated administrative state: A crisis of legitimacy. *Emory LJ*, 70:797, 2020.
1041. Sridipta Misra, Muthucumar Maheswaran, and Salman Hashmi. Social governance. In *Security Challenges and Approaches in Internet of Things*, pages 53–75. Springer, 2017.
1042. JH de O Alexandre, Marcelo LM Marinho, and Hermano P de Moura. Agile governance theory: operationalization. *Innovations in Systems and Software Engineering*, 16(1):3–44, 2020.
1043. L Xue and J Zhao. Toward agile governance: The pattern of emerging industry development and regulation. *Chinese Public Administration*, 8:28–34, 2019.
1044. Timothy F Bresnahan and Manuel Trajtenberg. General purpose technologies ‘engines of growth’? *Journal of econometrics*, 65(1):83–108, 1995.
1045. Manuel Trajtenberg. Ai as the next gpt: a political-economy perspective. Technical report, National Bureau of Economic Research, 2018.
1046. John Maynard Keynes. *The general theory of employment, interest, and money*. Springer, 2018.
1047. Clifford Bekar, Kenneth Carlaw, and Richard Lipsey. General purpose technologies in theory, application and controversy: a review. *Journal of Evolutionary Economics*, 28(5):1005–1033, 2018.
1048. Zhang Hui, Chen Hailong, and Liu Peng. An analysis of the microcosmic dynamic mechanism of general-purpose information technologies’ innovation in the age of intelligence: A longitudinal cases study of the information technological evolution of walmart. *Science Research Management*, 42(6):32, 2021.
1049. Craig Locatis. Technopoly: The surrender of culture to technology, 1994.
1050. Donna Haraway et al. A manifesto for cyborgs: Science, technology, and socialist feminism in the 1980s. *Feminism/post-modernism*, pages 190–233, 1990.
1051. Roger Silverstone and Leslie Haddon. Design and the domestication of information and communication technologies: Technical change and everyday life. 1996.
1052. Esmée Stouten. Exploring how developers could include the european commission’s ethics guidelines to strive toward trustworthy ai.
1053. Yi Zeng, Enmeng Lu, and Cunqing Huangfu. Linking artificial intelligence principles. *arXiv preprint arXiv:1812.04814*, 2018.
1054. Thierry Ménéssier. A “machiavellian moment” for artificial intelligence? the montreal declaration for the responsible development of ai. *Raisons politiques*, pages 67–81, 2020.
1055. Tim Miller. Explanation in artificial intelligence: Insights from the social sciences. *Artificial intelligence*, 267:1–38, 2019.
1056. Alejandro Barredo Arrieta, Natalia Díaz-Rodríguez, Javier Del Ser, Adrien Bennetot, Siham Tabik, Alberto Barbado, Salvador García, Sergio Gil-López, Daniel Molina, Richard Benjamins, et al. Explainable artificial intelligence (xai): Concepts, taxonomies, opportunities and challenges toward responsible ai. *Information Fusion*, 58:82–115, 2020.

1057. Nripsuta Ani Saxena, Karen Huang, Evan DeFilippis, Goran Radanovic, David C Parkes, and Yang Liu. How do fairness definitions fare? examining public attitudes towards algorithmic definitions of fairness. In *Proceedings of the 2019 AAAI/ACM Conference on AI, Ethics, and Society*, pages 99–106, 2019.
1058. Ehsan Toreini, Mhairi Aitken, Kovila PL Coopamootoo, Karen Elliott, Vladimiro Gonzalez Zelaya, Paolo Missier, Magdalene Ng, and Aad van Moorsel. Technologies for trustworthy machine learning: A survey in a socio-technical context. *arXiv preprint arXiv:2007.08911*, 2020.
1059. Simon Caton and Christian Haas. Fairness in machine learning: A survey. *arXiv preprint arXiv:2010.04053*, 2020.
1060. Haochen Liu, Yiqi Wang, Wenqi Fan, Xiaorui Liu, Yaxin Li, Shaili Jain, Yunhao Liu, Anil K Jain, and Jiliang Tang. Trustworthy ai: A computational perspective. *arXiv preprint arXiv:2107.06641*, 2021.
1061. Moritz Hardt, Eric Price, and Nati Srebro. Equality of opportunity in supervised learning. *Advances in neural information processing systems*, 29:3315–3323, 2016.
1062. Cynthia Dwork, Moritz Hardt, Toniann Pitassi, Omer Reingold, and Richard Zemel. Fairness through awareness. In *Proceedings of the 3rd innovations in theoretical computer science conference*, pages 214–226, 2012.
1063. Renzhe Xu, Peng Cui, Kun Kuang, Bo Li, Linjun Zhou, Zheyang Shen, and Wei Cui. Algorithmic decision making with conditional fairness. In *Proceedings of the 26th ACM SIGKDD International Conference on Knowledge Discovery & Data Mining*, pages 2125–2135, 2020.
1064. Niki Kilbertus, Mateo Rojas-Carulla, Giambattista Parascandolo, Moritz Hardt, Dominik Janzing, and Bernhard Schölkopf. Avoiding discrimination through causal reasoning. *Advances in Neural Information Processing Systems*, 30, 2017.
1065. Matt J Kusner, Joshua Loftus, Chris Russell, and Ricardo Silva. Counterfactual fairness. *Advances in Neural Information Processing Systems*, 30, 2017.
1066. Silvia Chiappa. Path-specific counterfactual fairness. In *Proceedings of the AAAI Conference on Artificial Intelligence*, volume 33, pages 7801–7808, 2019.
1067. Michael Xie, Neal Jean, Marshall Burke, David Lobell, and Stefano Ermon. Transfer learning from deep features for remote sensing and poverty mapping. In *Thirtieth AAAI Conference on Artificial Intelligence*, 2016.
1068. Neal Jean, Marshall Burke, Michael Xie, W Matthew Davis, David B Lobell, and Stefano Ermon. Combining satellite imagery and machine learning to predict poverty. *Science*, 353(6301):790–794, 2016.
1069. Fisher Yu, Haofeng Chen, Xin Wang, Wenqi Xian, Yingying Chen, Fangchen Liu, Vashisht Madhavan, and Trevor Darrell. Bdd100k: A diverse driving dataset for heterogeneous multitask learning. In *Proceedings of the IEEE/CVF conference on computer vision and pattern recognition*, pages 2636–2645, 2020.
1070. Pei Sun, Henrik Kretschmar, Xerxes Dotiwalla, Aurelien Chouard, Vijaysai Patnaik, Paul Tsui, James Guo, Yin Zhou, Yuning Chai, Benjamin Caine, et al. Scalability in perception for autonomous driving: Waymo open dataset. In *Proceedings of the IEEE/CVF Conference on Computer Vision and Pattern Recognition*, pages 2446–2454, 2020.
1071. Ehab A AlBadawy, Ashirbani Saha, and Maciej A Mazurowski. Deep learning for segmentation of brain tumors: Impact of cross-institutional training and testing. *Medical physics*, 45(3):1150–1158, 2018.
1072. Dengxin Dai and Luc Van Gool. Dark model adaptation: Semantic image segmentation from daytime to nighttime. In *2018 21st International Conference on Intelligent Transportation Systems (ITSC)*, pages 3819–3824. IEEE, 2018.
1073. Jianhua Han, Xiwen Liang, Hang Xu, Kai Chen, Lanqing Hong, Chaoqiang Ye, Wei Zhang, Zhenguo Li, Xiaodan Liang, and Chunjing Xu. Soda10m: Towards large-scale object detection benchmark for autonomous driving. *arXiv preprint arXiv:2106.11118*, 2021.
1074. Mateusz Buda, Ashirbani Saha, Ruth Walsh, Sujata Ghate, Nianyi Li, Albert Świącicki, Joseph Y Lo, and Maciej A Mazurowski. A data set and deep learning algorithm for the detection of masses and architectural distortions in digital breast tomosynthesis images. *JAMA network open*, 4(8):e2119100–e2119100, 2021.
1075. Bernd W Wirtz, Jan C Weyerer, and Carolin Geyer. Artificial intelligence and the public sector—applications and challenges. *International Journal of Public Administration*, 42(7):596–615, 2019.
1076. Patricia Gomes Rêgo de Almeida, Carlos Denner dos Santos, and Josivania Silva Farias. Artificial intelligence regulation: a framework for governance. *Ethics and Information Technology*, pages 1–21, 2021.
1077. Nicholas Carlini, Chang Liu, Úlfar Erlingsson, Jernej Kos, and Dawn Xiaodong Song. The secret sharer: Evaluating and testing unintended memorization in neural networks. In *USENIX Security Symposium*, 2019.
1078. Huseyin A Inan, Osman Ramadan, Lukas Wutschitz, Daniel Jones, Victor Rühle, James Withers, and Robert Sim. Training data leakage analysis in language models. *arXiv preprint arXiv:2101.05405*, 2021.
1079. Borja Balle, Giovanni Cherubin, and Jamie Hayes. Reconstructing training data with informed adversaries. In *NeurIPS 2021 Workshop Privacy in Machine Learning*, 2021.
1080. Shangyu Xie and Yuan Hong. Reconstruction attack on instance encoding for language understanding. In *Proceedings of the 2021 Conference on Empirical Methods in Natural Language Processing*, pages 2038–2044, 2021.
1081. R Thomas McCoy, Paul Smolensky, Tal Linzen, Jianfeng Gao, and Asli Celikyilmaz. How much do language models copy from their training data? evaluating linguistic novelty in text generation using raven. *arXiv preprint arXiv:2111.09509*, 2021.
1082. Reza Shokri, Marco Stronati, Congzheng Song, and Vitaly Shmatikov. Membership inference attacks against machine learning models. In *2017 IEEE Symposium on Security and Privacy (SP)*, pages 3–18. IEEE, 2017.
1083. Vasishth Duddu, Antoine Boutet, and Virat Shejwalkar. Quantifying privacy leakage in graph embedding. In *MobiQuitous 2020 - 17th EAI International Conference on Mobile and Ubiquitous Systems: Computing, Networking and Services*, page 76–85. Association for Computing Machinery, 2020.

1084. Saeed Mahloujifar, Huseyin A Inan, Melissa Chase, Esha Ghosh, and Marcello Hasegawa. Membership inference on word embedding and beyond. *arXiv preprint arXiv:2106.11384*, 2021.
1085. Hongbin Liu, Jinyuan Jia, Wenjie Qu, and Neil Zhenqiang Gong. Encodermi: Membership inference against pre-trained encoders in contrastive learning. In *Proceedings of the 2021 ACM SIGSAC Conference on Computer and Communications Security*, pages 2081–2095, 2021.
1086. Abhyuday Jagannatha, Bhanu Pratap Singh Rawat, and Hong Yu. Membership inference attack susceptibility of clinical language models. *arXiv preprint arXiv:2104.08305*, 2021.
1087. Santiago Zanella-Béguelin, Lukas Wutschitz, Shruti Tople, Victor Rühle, Andrew Pavard, Olga Ohrimenko, Boris Köpf, and Marc Brockschmidt. Analyzing information leakage of updates to natural language models. In *Proceedings of the 2020 ACM SIGSAC Conference on Computer and Communications Security*, pages 363–375, 2020.
1088. Ahmed Salem, Apratim Bhattacharya, Michael Backes, Mario Fritz, and Yang Zhang. Updates-leak: Data set inference and reconstruction attacks in online learning. In *29th {USENIX} Security Symposium ({USENIX} Security 20)*, pages 1291–1308, 2020.
1089. Shaohua Ding, Yulong Tian, Fengyuan Xu, Qun Li, and Sheng Zhong. Trojan attack on deep generative models in autonomous driving. In *International Conference on Security and Privacy in Communication Systems*, pages 299–318. Springer, 2019.
1090. Roei Schuster, Congzheng Song, Eran Tromer, and Vitaly Shmatikov. You autocomplete me: Poisoning vulnerabilities in neural code completion. In *30th {USENIX} Security Symposium ({USENIX} Security 21)*, 2021.
1091. Wenkai Yang, Lei Li, Zhiyuan Zhang, Xuancheng Ren, Xu Sun, and Bin He. Be careful about poisoned word embeddings: Exploring the vulnerability of the embedding layers in nlp models. In *Proceedings of the 2021 Conference of the North American Chapter of the Association for Computational Linguistics: Human Language Technologies*, pages 2048–2058, 2021.
1092. Eric Wallace, Shi Feng, Nikhil Kandpal, Matt Gardner, and Sameer Singh. Universal adversarial triggers for attacking and analyzing nlp. In *Proceedings of the 2019 Conference on Empirical Methods in Natural Language Processing and the 9th International Joint Conference on Natural Language Processing (EMNLP-IJCNLP)*, pages 2153–2162, 2019.
1093. Eric Wallace, Tony Z Zhao, Shi Feng, and Sameer Singh. Customizing triggers with concealed data poisoning. *arXiv e-prints*, pages arXiv–2010, 2020.
1094. Anthony W Flores, Kristin Bechtel, and Christopher T Lowenkamp. False positives, false negatives, and false analyses: A rejoinder to machine bias: There’s software used across the country to predict future criminals. and it’s biased against blacks. *Fed. Probation*, 80:38, 2016.
1095. Julia Angwin, Jeff Larson, Surya Mattu, and Lauren Kirchner. Machine bias: There’s software used across the country to predict future criminals. and it’s biased against blacks. *ProPublica*, May, 2016.
1096. Richard Berk. The role of race in forecasts of violent crime. *Race and social problems*, 2009.
1097. Bill Dedman et al. The color of money. *Atlanta Journal-Constitution*, 1988.
1098. Sharad Goel, Justin M Rao, Ravi Shroff, et al. Precinct or prejudice? understanding racial disparities in new york city’s stop-and-frisk policy. *The Annals of Applied Statistics*, 10(1):365–394, 2016.
1099. Ayanna M. Howard and Jason Borenstein. Trust and bias in robots. *American Scientist*, 107:86, 2019.
1100. James A. Rodger and Parag C. Pendharkar. A field study of the impact of gender and user’s technical experience on the performance of voice-activated medical tracking application. *International Journal of Human-computer Studies International Journal of Man-machine Studies*, 60:529–544, 2004.
1101. John A. Bullinaria and Joseph P. Levy. Extracting semantic representations from word co-occurrence statistics: a computational study. *Behavior Research Methods*, 39:510–526, 2007.
1102. Michael Stubbs. *Text and corpus analysis: Computer-assisted studies of language and culture*. Blackwell Oxford, 1996.
1103. Deborah Hellman. Big data and compounding injustice. *Journal of Moral Philosophy*, 2021.
1104. Joy Buolamwini and Timnit Gebru. Gender shades: Intersectional accuracy disparities in commercial gender classification. In *Conference on fairness, accountability and transparency*, pages 77–91. PMLR, 2018.
1105. Ifeoma Ajunwa. The paradox of automation as anti-bias intervention. *Social Science Research Network*, page 1671, 2020.
1106. Botty Dimanov, Umang Bhatt, Mateja Jamnik, and Adrian Weller. You shouldn’t trust me: Learning models which conceal unfairness from multiple explanation methods. In *European Conference on Artificial Intelligence*, 2020.
1107. Ismael Garrido-Muñoz, Arturo Montejo-Ráez, Fernando Martínez-Santiago, and L. Alfonso Ureña-López. A survey on bias in deep nlp. *Applied Sciences*, 11:3184, 2021.
1108. Pengyu Cheng, Weituo Hao, Siyang Yuan, Shijing Si, and Lawrence Carin. Fairfil: Contrastive neural debiasing method for pretrained text encoders. In *International Conference on Learning Representations*, 2021.
1109. Jaimeen Ahn and Alice Oh. Mitigating language-dependent ethnic bias in bert. *arXiv: Computation and Language*, 2021.
1110. Marzieh Mozafari, Reza Farahbakhsh, and Noël Crespi. Hate speech detection and racial bias mitigation in social media based on BERT model. *CoRR*, abs/2008.06460, 2020.
1111. Albert Xu, Eshaan Pathak, Eric Wallace, Suchin Gururangan, Maarten Sap, and Dan Klein. Detoxifying language models risks marginalizing minority voices. In Kristina Toutanova, Anna Rumshisky, Luke Zettlemoyer, Dilek Hakkani-Tür, Iz Beltagy, Steven Bethard, Ryan Cotterell, Tanmoy Chakraborty, and Yichao Zhou, editors, *Proceedings of the 2021 Conference of the North American Chapter of the Association for Computational Linguistics: Human Language Technologies, NAACL-HLT 2021, Online, June 6-11, 2021*, pages 2390–2397. Association for Computational Linguistics, 2021.



1112. Enyan Dai and Suhang Wang. Say no to the discrimination: Learning fair graph neural networks with limited sensitive attribute information. In *Web Search and Data Mining*, 2021.
1113. Valeriia Cherepanova, Vedant Nanda, Micah Goldblum, John P. Dickerson, and Tom Goldstein. Technical challenges for training fair neural networks. *arXiv: Learning*, 2021.
1114. Aylin Caliskan, Joanna J. Bryson, and Arvind Narayanan. Semantics derived automatically from language corpora contain human-like biases. *Science*, 356:183–186, 2017.
1115. Abubakar Abid, Maheen Farooqi, and James Zou. Persistent anti-muslim bias in large language models. *arXiv preprint arXiv:2101.05783*, 2021.
1116. Moin Nadeem, Anna Bethke, and Siva Reddy. Stereoset: Measuring stereotypical bias in pretrained language models. *arXiv: Computation and Language*, 2020.
1117. Ben Hutchinson, Vinodkumar Prabhakaran, Emily Denton, Kellie Webster, Yu Zhong, and Stephen Denuyl. Social biases in nlp models as barriers for persons with disabilities. In *Meeting of the Association for Computational Linguistics*, 2020.
1118. Ruha Benjamin. Race after technology: Abolitionist tools for the new jim code. 2019.
1119. Yolande Strengers, Lizhen Qu, Qionghai Xu, and Jarrod Knibbe. Adhering, steering, and queering: Treatment of gender in natural language generation. In *Human Factors in Computing Systems*, 2020.
1120. Thiago Dias Oliva, Dennys Marcelo Antonialli, and Alessandra Gomes. Fighting hate speech, silencing drag queens? artificial intelligence in content moderation and risks to lgbtq voices online. *Sexuality and Culture*, 25:700–732, 2021.
1121. Allison Koenecke, Andrew Joo Hun Nam, Emily Lake, Joe Nudell, Minnie Quartey, Zion Mengesha, Connor Toups, John R. Rickford, Dan Jurafsky, and Sharad Goel. Racial disparities in automated speech recognition. *Proceedings of the National Academy of Sciences of the United States of America*, 117:7684–7689, 2020.
1122. Kaitlyn Zhou, Kawin Ethayarajh, and Dan Jurafsky. Frequency-based distortions in contextualized word embeddings. *arXiv: Computation and Language*, 2021.
1123. Kathleen Creel and Deborah Hellman. The algorithmic leviathan: Arbitrariness, fairness, and opportunity in algorithmic decision making systems. 2021.
1124. Su Lin Blodgett and Brendan O’Connor. Racial disparity in natural language processing: A case study of social media african-american english. *arXiv: Computers and Society*, 2017.
1125. Haoran Zhang, Amy X Lu, Mohamed Abdalla, Matthew McDermott, and Marzyeh Ghassemi. Hurtful words: quantifying biases in clinical contextual word embeddings. In *proceedings of the ACM Conference on Health, Inference, and Learning*, pages 110–120, 2020.
1126. Milagros Miceli, Martin Schuessler, and Tianling Yang. Between subjectivity and imposition: Power dynamics in data annotation for computer vision. *Proceedings of the ACM on Human-Computer Interaction*, 4(CSCW2):1–25, 2020.
1127. Vinay Uday Prabhu and Abeba Birhane. Large image datasets: A pyrrhic win for computer vision? *arXiv: Computers and Society*, 2020.
1128. Jieyu Zhao, Tianlu Wang, Mark Yatskar, Vicente Ordonez, and Kai-Wei Chang. Men also like shopping: Reducing gender bias amplification using corpus-level constraints. In *Empirical Methods in Natural Language Processing*, 2017.
1129. Tianlu Wang, Jieyu Zhao, Mark Yatskar, Kai-Wei Chang, and Vicente Ordonez. Balanced datasets are not enough: Estimating and mitigating gender bias in deep image representations. In *International Conference on Computer Vision*, 2019.
1130. Shengyu Jia, Tao Meng, Jieyu Zhao, and Kai-Wei Chang. Mitigating gender bias amplification in distribution by posterior regularization. In *Meeting of the Association for Computational Linguistics*, 2020.
1131. Isaac Caswell, Julia Kreutzer, Lisa Wang, Ahsan Wahab, Daan van Esch, Nasanbayar Ulzii-Orshikh, Allahsera Auguste Tapo, Nishant Subramani, Artem Sokolov, Claytone Sikasote, Monang Setyawan, Supheakmungkol Sarin, Sokhar Samb, Benoît Sagot, Clara E. Rivera, Annette Rios, Isabel Papadimitriou, Salomey Osei, Pedro Javier Ortiz Suárez, Iroro Orife, Kelechi Gueji, Rubungo Andre Niyongabo, Toan Q. Nguyen, Mathias Müller, André Müller, Shamsuddeen Hassan Muhammad, Nanda Muhammad, Ayanda Mnyakeni, Jamshidbek Mirzakhlov, Tapiwanashe Matangira, Colin Leong, Nze Lawson, Sneha Kudugunta, Yacine Jernite, Mathias Jenny, Orhan Firat, Bonaventure F. P. Dossou, Sakhile Dlamini, Nisansa de Silva, Sakine Çabuk Ballı, Stella Biderman, Alessia Battisti, Ahmed Baruwa, Ankur Bapna, Pallavi Baljekar, Israel Abebe Azime, Ayodele Awokoya, Duygu Ataman, Orevaoghene Ahia, Oghenefego Ahia, Sweta Agrawal, and Mofetoluwa Adeyemi. Quality at a glance: An audit of web-crawled multilingual datasets. *arXiv: Computation and Language*, 2021.
1132. Brian Dalessandro, Cathy O’Neil, and Tom LaGatta. Conscientious classification: A data scientist’s guide to discrimination-aware classification. 2017.
1133. Nikhil Garg, Londa Schiebinger, Dan Jurafsky, and James Zou. Word embeddings quantify 100 years of gender and ethnic stereotypes. *Proceedings of the National Academy of Sciences of the United States of America*, 115:201720347, 2018.
1134. Thomas Manzini, Lim Yao Chong, Alan W. Black, and Yulia Tsvetkov. Black is to criminal as caucasian is to police: Detecting and removing multiclass bias in word embeddings. In *North American Chapter of the Association for Computational Linguistics*, 2019.
1135. Anthony G. Greenwald, Debbie E. McGhee, and Jordan L. K. Schwartz. Measuring individual differences in implicit cognition: The implicit association test. *Journal of Personality and Social Psychology*, 74:1464–1480, 1998.
1136. Chandler May, Alex Wang, Shikha Bordia, Samuel R. Bowman, and Rachel Rudinger. On measuring social biases in sentence encoders. In *North American Chapter of the Association for Computational Linguistics*, 2019.
1137. Keita Kurita, Nidhi Vyas, Ayush Pareek, Alan W. Black, and Yulia Tsvetkov. Measuring bias in contextualized word representations. 2019.

1138. Paul Pu Liang, Irene Mengze Li, Emily Zheng, Yao Chong Lim, Ruslan Salakhutdinov, and Louis-Philippe Morency. Towards debiasing sentence representations. In *Meeting of the Association for Computational Linguistics*, 2020.
1139. Tianlu Wang, Xi Victoria Lin, Nazneen Fatema Rajani, Bryan McCann, Vicente Ordonez, and Caiming Xiong. Double-hard debias: Tailoring word embeddings for gender bias mitigation. In *Meeting of the Association for Computational Linguistics*, 2020.
1140. Rishi Bommasani, Kelly Davis, and Claire Cardie. Interpreting pretrained contextualized representations via reductions to static embeddings. In *Meeting of the Association for Computational Linguistics*, 2020.
1141. Jieyu Zhao, Tianlu Wang, Mark Yatskar, Vicente Ordonez, and Kai-Wei Chang. Gender bias in coreference resolution: Evaluation and debiasing methods. In *North American Chapter of the Association for Computational Linguistics*, 2018.
1142. Ji Ho Park, Jamin Shin, and Pascale Fung. Reducing gender bias in abusive language detection. In *Empirical Methods in Natural Language Processing*, 2018.
1143. Emily Dinan, Angela Fan, Adina Williams, Jack Urbanek, Douwe Kiela, and Jason Weston. Queens are powerful too: Mitigating gender bias in dialogue generation. In *Empirical Methods in Natural Language Processing*, 2020.
1144. Brian Hu Zhang, Blake Lemoine, and Margaret Mitchell. Mitigating unwanted biases with adversarial learning. In *National Conference on Artificial Intelligence*, 2018.
1145. Haochen Liu, Wentao Wang, Yiqi Wang, Hui Liu, Zitao Liu, and Jiliang Tang. Mitigating gender bias for neural dialogue generation with adversarial learning. In *Empirical Methods in Natural Language Processing*, 2020.
1146. Sheng Liang, Philipp Dufter, and Hinrich Schütze. Monolingual and multilingual reduction of gender bias in contextualized representations. In *International Conference on Computational Linguistics*, 2020.
1147. Nathan Kallus, Xiaojie Mao, and Angela Zhou. Assessing algorithmic fairness with unobserved protected class using data combination. *Management Science*, 2021.
1148. Alex Beutel, Ed H. Chi, Jilin Chen, and Zhe Zhao. Data decisions and theoretical implications when adversarially learning fair representations. *arXiv: Learning*, 2017.
1149. Inioluwa Deborah Raji and Joy Buolamwini. Actionable auditing: Investigating the impact of publicly naming biased performance results of commercial ai products. In *National Conference on Artificial Intelligence*, 2019.
1150. Inioluwa Deborah Raji, Timnit Gebru, Margaret Mitchell, Joy Buolamwini, Joonseok Lee, and Emily Denton. Saving face: Investigating the ethical concerns of facial recognition auditing. In *National Conference on Artificial Intelligence*, 2020.
1151. Benjamin Wilson, Judy Hoffman, and Jamie Morgenstern. Predictive inequity in object detection. *arXiv: Computer Vision and Pattern Recognition*, 2019.
1152. Terrance DeVries, Ishan Misra, Changhan Wang, and Laurens van der Maaten. Does object recognition work for everyone. In *Computer Vision and Pattern Recognition*, 2019.
1153. Shreya Shankar, Yoni Halpern, Eric Breck, James Atwood, Jimbo Wilson, and D. Sculley. No classification without representation: Assessing geodiversity issues in open data sets for the developing world. *arXiv: Machine Learning*, 2017.
1154. Pierre Stock and Moustapha Cisse. Convnets and imagenet beyond accuracy: Understanding mistakes and uncovering biases. In *European Conference on Computer Vision*, 2018.
1155. Lisa Anne Hendricks, Kaylee Burns, Kate Saenko, Trevor Darrell, and Anna Rohrbach. Women also snowboard: Overcoming bias in captioning models. In *European Conference on Computer Vision*, 2018.
1156. Zheyang Shen, Jiashuo Liu, Yue He, Xingxuan Zhang, Renzhe Xu, Han Yu, and Peng Cui. Towards out-of-distribution generalization: A survey. *arXiv preprint arXiv:2108.13624*, 2021.
1157. Yoshua Bengio, Aaron Courville, and Pascal Vincent. Representation learning: A review and new perspectives. *IEEE transactions on pattern analysis and machine intelligence*, 35(8):1798–1828, 2013.
1158. Irina Higgins, Loïc Matthey, Arka Pal, Christopher P. Burgess, Xavier Glorot, Matthew M. Botvinick, Shakir Mohamed, and Alexander Lerchner. beta-vae: Learning basic visual concepts with a constrained variational framework. In *ICLR*, 2017.
1159. Hyunjik Kim and Andriy Mnih. Disentangling by factorising. In *International Conference on Machine Learning*, pages 2654–2663, 2018.
1160. Francesco Locatello, Stefan Bauer, Mario Lucic, Gunnar Raetsch, Sylvain Gelly, Bernhard Schölkopf, and Olivier Bachem. Challenging common assumptions in the unsupervised learning of disentangled representations. In *ICML*, pages 4114–4124. PMLR, 2019.
1161. Felix Leeb, Giulia Lanzillotta, Yashas Annadani, Michel Besserve, Stefan Bauer, and Bernhard Schölkopf. Structure by Architecture: Disentangled Representations without Regularization. *arXiv e-prints*, page arXiv:2006.07796, June 2020.
1162. Andrea Dittadi, Frederik Träuble, Francesco Locatello, Manuel Wüthrich, Vaibhav Agrawal, Ole Winther, Stefan Bauer, and Bernhard Schölkopf. On the transfer of disentangled representations in realistic settings. *arXiv preprint arXiv:2010.14407*, 2020.
1163. Frederik Träuble, Elliot Creager, Niki Kilbertus, Francesco Locatello, Andrea Dittadi, Anirudh Goyal, Bernhard Schölkopf, and Stefan Bauer. On disentangled representations learned from correlated data. In *ICML*, pages 10401–10412. PMLR, 2021.
1164. Mengyue Yang, Furui Liu, Zhitang Chen, Xinwei Shen, Jianye Hao, and Jun Wang. Causalvae: disentangled representation learning via neural structural causal models. In *CVPR*, pages 9593–9602, 2021.
1165. Xinwei Shen, Furui Liu, Hanze Dong, Qing Lian, Zhitang Chen, and Tong Zhang. Disentangled generative causal representation learning. *arXiv preprint arXiv:2010.02637*, 2020.

1166. Bernhard Schölkopf, Francesco Locatello, Stefan Bauer, Nan Rosemary Ke, Nal Kalchbrenner, Anirudh Goyal, and Yoshua Bengio. Toward causal representation learning. *Proceedings of the IEEE*, 109(5):612–634, 2021.
1167. Yaroslav Ganin and Victor Lempitsky. Unsupervised domain adaptation by backpropagation. In *ICML*, pages 1180–1189. PMLR, 2015.
1168. Eric Tzeng, Judy Hoffman, Ning Zhang, Kate Saenko, and Trevor Darrell. Deep domain confusion: Maximizing for domain invariance. *arXiv preprint arXiv:1412.3474*, 2014.
1169. Saeid Motiian, Marco Piccirilli, Donald A Adjeroh, and Gianfranco Doretto. Unified deep supervised domain adaptation and generalization. In *ICCV*, pages 5715–5725, 2017.
1170. Jindong Wang, Wenjie Feng, Yiqiang Chen, Han Yu, Meiyu Huang, and Philip S Yu. Visual domain adaptation with manifold embedded distribution alignment. In *ACM Multimedia*, pages 402–410, 2018.
1171. Yaroslav Ganin, Evgeniya Ustinova, Hana Ajakan, Pascal Germain, Hugo Larochelle, François Laviolette, Mario Marchand, and Victor Lempitsky. Domain-adversarial training of neural networks. *The journal of machine learning research*, 17(1):2096–2030, 2016.
1172. Haoliang Li, Sinno Jialin Pan, Shiqi Wang, and Alex C Kot. Domain generalization with adversarial feature learning. In *CVPR*, pages 5400–5409, 2018.
1173. Jonas Peters, Peter Bühlmann, and Nicolai Meinshausen. Causal inference by using invariant prediction: identification and confidence intervals. *Journal of the Royal Statistical Society: Series B (Statistical Methodology)*, 78(5):947–1012, 2016.
1174. Niklas Pfister, Peter Bühlmann, and Jonas Peters. Invariant causal prediction for sequential data. *Journal of the American Statistical Association*, 2018.
1175. Dominik Rothenhäusler, Nicolai Meinshausen, Peter Bühlmann, and Jonas Peters. Anchor regression: heterogeneous data meets causality. *arXiv preprint arXiv:1801.06229*, 2018.
1176. Martin Arjovsky, Léon Bottou, Ishaan Gulrajani, and David Lopez-Paz. Invariant risk minimization. *arXiv preprint arXiv:1907.02893*, 2019.
1177. Kartik Ahuja, Karthikeyan Shanmugam, Kush Varshney, and Amit Dhurandhar. Invariant risk minimization games. In *ICML*, pages 145–155. PMLR, 2020.
1178. David Krueger, Ethan Caballero, Joern-Henrik Jacobsen, Amy Zhang, Jonathan Binas, Dinghui Zhang, Remi Le Priol, and Aaron Courville. Out-of-distribution generalization via risk extrapolation (rex). In *ICML*, pages 5815–5826. PMLR, 2021.
1179. Zheyuan Shen, Peng Cui, Kun Kuang, Bo Li, and Peixuan Chen. Causally regularized learning with agnostic data selection bias. In *ACM Multimedia*, pages 411–419, 2018.
1180. Kun Kuang, Peng Cui, Susan Athey, Ruoxuan Xiong, and Bo Li. Stable prediction across unknown environments. In *Proceedings of the 24th ACM SIGKDD International Conference on Knowledge Discovery & Data Mining*, pages 1617–1626, 2018.
1181. Kun Kuang, Ruoxuan Xiong, Peng Cui, Susan Athey, and Bo Li. Stable prediction with model misspecification and agnostic distribution shift. In *AAAI*, volume 34, pages 4485–4492, 2020.
1182. Zheyuan Shen, Peng Cui, Tong Zhang, and Kun Kuang. Stable learning via sample reweighting. In *AAAI*, volume 34, pages 5692–5699, 2020.
1183. Zheyuan Shen, Peng Cui, Jiashuo Liu, Tong Zhang, Bo Li, and Zhitang Chen. Stable learning via differentiated variable decorrelation. In *Proceedings of the 26th ACM SIGKDD International Conference on Knowledge Discovery & Data Mining*, pages 2185–2193, 2020.
1184. Xingxuan Zhang, Peng Cui, Renzhe Xu, Linjun Zhou, Yue He, and Zheyuan Shen. Deep stable learning for out-of-distribution generalization. In *CVPR*, pages 5372–5382, 2021.
1185. Renzhe Xu, Peng Cui, Zheyuan Shen, Xingxuan Zhang, and Tong Zhang. Why stable learning works? a theory of covariate shift generalization. *arXiv preprint arXiv:2111.02355*, 2021.
1186. Peyman Mohajerin Esfahani and Daniel Kuhn. Data-driven distributionally robust optimization using the wasserstein metric: Performance guarantees and tractable reformulations. *Mathematical Programming*, 171(1-2):115–166, 2018.
1187. John Duchi and Hongseok Namkoong. Learning models with uniform performance via distributionally robust optimization. *arXiv preprint arXiv:1810.08750*, 2018.
1188. Aman Sinha, Hongseok Namkoong, and John Duchi. Certifying some distributional robustness with principled adversarial training. *ICLR*, 2018.
1189. Shiori Sagawa, Pang Wei Koh, Tatsunori B Hashimoto, and Percy Liang. Distributionally robust neural networks for group shifts: On the importance of regularization for worst-case generalization. *arXiv preprint arXiv:1911.08731*, 2019.
1190. Jiashuo Liu, Zheyuan Shen, Peng Cui, Linjun Zhou, Kun Kuang, Bo Li, and Yishi Lin. Stable adversarial learning under distributional shifts. In *AAAI*, volume 35, pages 8662–8670, 2021.
1191. Masanori Koyama and Shoichiro Yamaguchi. Out-of-distribution generalization with maximal invariant predictor. *arXiv preprint arXiv:2008.01883*, 2020.
1192. Shiyu Chang, Yang Zhang, Mo Yu, and Tommi Jaakkola. Invariant rationalization. In *International Conference on Machine Learning*, pages 1448–1458. PMLR, 2020.
1193. Jiashuo Liu, Zheyuan Hu, Peng Cui, Bo Li, and Zheyuan Shen. Heterogeneous risk minimization. *arXiv preprint arXiv:2105.03818*, 2021.
1194. Jiashuo Liu, Zheyuan Hu, Peng Cui, Bo Li, and Zheyuan Shen. Kernelized heterogeneous risk minimization. *arXiv preprint arXiv:2110.12425*, 2021.

1195. Katarzyna Szymielewicz, Anna Bacciarelli, Fanny Hidvegi, Agata Foryciarz, Soizic Pénicaud, and Matthias Spielkamp. Where do algorithmic accountability and explainability frameworks take us in the real world? from theory to practice. In *Proceedings of the 2020 Conference on Fairness, Accountability, and Transparency*, pages 689–689, 2020.
1196. Alexandra Reeve Givens and Meredith Ringel Morris. Centering disability perspectives in algorithmic fairness, accountability, & transparency. In *Proceedings of the 2020 Conference on Fairness, Accountability, and Transparency*, pages 684–684, 2020.
1197. Muhammad Aurangzeb Ahmad, Ankur Teredesai, and Carly Eckert. Fairness, accountability, transparency in ai at scale: Lessons from national programs. In *Proceedings of the 2020 Conference on Fairness, Accountability, and Transparency*, pages 690–690, 2020.
1198. Helen Smith. Clinical ai: opacity, accountability, responsibility and liability. *AI & SOCIETY*, 36(2):535–545, 2021.
1199. International Business Machines Corporation. Ibm design for ai: Accountability. <https://www.ibm.com/design/ai/ethics/accountability>.
1200. Organization for Economic Cooperation and Development. Oecd.ai policy observatory: Accountability (principle 1.5). <https://oecd.ai/en/dashboards/ai-principles/P9>.
1201. US. Government Accountability Office. *Artificial Intelligence: An Accountability Framework for Federal Agencies and Other Entities*. GAO-21-519SP, 2021.
1202. Yinzhi Cao and Junfeng Yang. Towards making systems forget with machine unlearning. In *2015 IEEE Symposium on Security and Privacy*, pages 463–480. IEEE, 2015.
1203. Lucas Bourtole, Varun Chandrasekaran, Christopher A Choquette-Choo, Hengrui Jia, Adelin Travers, Baiwu Zhang, David Lie, and Nicolas Papernot. Machine unlearning. In *2021 IEEE Symposium on Security and Privacy (SP)*, pages 141–159. IEEE, 2021.
1204. Aditya Golatkar, Alessandro Achille, and Stefano Soatto. Eternal sunshine of the spotless net: Selective forgetting in deep networks. In *Proceedings of the IEEE/CVF Conference on Computer Vision and Pattern Recognition*, pages 9304–9312, 2020.
1205. TONY GINART, MELODY GUAN, GREG VALIANT, and JAMES ZOU. Making ai forget you: Data deletion in machine learning. *Advances in Neural Information Processing Systems*, 2019.
1206. Chuan Guo, Tom Goldstein, Awni Hannun, and Laurens Van Der Maaten. Certified data removal from machine learning models. In *International Conference on Machine Learning*, pages 3832–3842. PMLR, 2020.
1207. Min Chen, Zhikun Zhang, Tianhao Wang, Michael Backes, Mathias Humbert, and Yang Zhang. When machine unlearning jeopardizes privacy. In *Proceedings of the 2021 ACM SIGSAC Conference on Computer and Communications Security*, pages 896–911, 2021.
1208. Cynthia Dwork and Aaron Roth. The algorithmic foundations of differential privacy. *Theoretical Computer Science*, 9(3-4):211–407, 2014.
1209. Martin Abadi, Andy Chu, Ian Goodfellow, H Brendan McMahan, Ilya Mironov, Kunal Talwar, and Li Zhang. Deep learning with differential privacy. In *Proceedings of the 2016 ACM SIGSAC conference on computer and communications security*, pages 308–318, 2016.
1210. Lei Yu, Ling Liu, Calton Pu, Mehmet Emre Gursoy, and Stacey Truex. Differentially private model publishing for deep learning. In *2019 IEEE Symposium on Security and Privacy (SP)*, pages 332–349. IEEE, 2019.
1211. Yuzhe Ma, Xiaojin Zhu, and Justin Hsu. Data poisoning against differentially-private learners: Attacks and defenses. In *International Joint Conference on Artificial Intelligence*, page 4732–4738, 2019.
1212. Gavin Kerrigan, Dylan Slack, and Jens Tuyls. Differentially private language models benefit from public pre-training. In *Proceedings of the Second Workshop on Privacy in NLP*, pages 39–45, 2020.
1213. Chen Qu, Weize Kong, Liu Yang, Mingyang Zhang, Michael Bendersky, and Marc Najork. Natural language understanding with privacy-preserving bert. In *Proceedings of the 30th ACM International Conference on Information & Knowledge Management*, pages 1488–1497, 2021.
1214. Xiang Yue, Minxin Du, Tianhao Wang, Yaliang Li, Huan Sun, and Sherman SM Chow. Differential privacy for text analytics via natural text sanitization. In *Findings of the Association for Computational Linguistics: ACL-IJCNLP 2021*, pages 3853–3866, 2021.
1215. Xuechen Li, Florian Tramèr, Percy Liang, and Tatsunori Hashimoto. Large language models can be strong differentially private learners. *arXiv preprint arXiv:2110.05679*, 2021.
1216. Shlomo Hoory, Amir Feder, Avichai Tendler, Alon Cohen, Sofia Erell, Itay Laish, Hootan Nakhost, Uri Stemmer, Ayelet Benjamini, Avinatan Hassidim, et al. Learning and evaluating a differentially private pre-trained language model. In *Proceedings of the Third Workshop on Privacy in Natural Language Processing*, pages 21–29, 2021.
1217. Matthew Jagielski, Jonathan Ullman, and Alina Oprea. Auditing differentially private machine learning: How private is private sgd? *Advances in Neural Information Processing Systems*, 33, 2020.
1218. Josep Domingo-Ferrer, David Sánchez, and Alberto Blanco-Justicia. The limits of differential privacy (and its misuse in data release and machine learning). *Communications of the ACM*, 64(7):33–35, 2021.
1219. Chris J. Kennedy, Geoff Bacon, Alexander Sahn, and Claudia von Vacano. Constructing interval variables via faceted rasch measurement and multitask deep learning: a hate speech application. *arXiv: Computation and Language*, 2020.
1220. Maarten Sap, Saadia Gabriel, Lianhui Qin, Dan Jurafsky, Noah A. Smith, and Yejin Choi. Social bias frames: Reasoning about social and power implications of language. In *Meeting of the Association for Computational Linguistics*, 2020.
1221. Yonatan Oren, Shiori Sagawa, Tatsunori B. Hashimoto, and Percy Liang. Distributionally robust language modeling. In *Empirical Methods in Natural Language Processing*, 2019.

1222. Xuhui Zhou, Maarten Sap, Swabha Swayamdipta, Noah A. Smith, and Yejin Choi. Challenges in automated debiasing for toxic language detection. In *Conference of the European Chapter of the Association for Computational Linguistics*, 2021.
1223. Michael Kearns, Seth Neel, Aaron Roth, and Zhiwei Steven Wu. Preventing fairness gerrymandering: Auditing and learning for subgroup fairness. *arXiv: Learning*, 2017.
1224. Ankit Kulshrestha and Ilya Safro. Fairlearn: Configurable and interpretable algorithmic fairness. 2021.
1225. Alex Wang, Yada Pruksachatkun, Nikita Nangia, Amanpreet Singh, Julian Michael, Felix Hill, Omer Levy, and Samuel R. Bowman. Superglue: A stickier benchmark for general-purpose language understanding systems. *arXiv preprint arXiv:1905.00537*, 2019.
1226. Junjie Hu, Sebastian Ruder, Aditya Siddhant, Graham Neubig, Orhan Firat, and Melvin Johnson. Xtreme: A massively multilingual multi-task benchmark for evaluating cross-lingual generalisation. In *International Conference on Machine Learning*, pages 4411–4421. PMLR, 2020.
1227. Yaobo Liang, Nan Duan, Yeyun Gong, Ning Wu, Fenfei Guo, Weizhen Qi, Ming Gong, Linjun Shou, Daxin Jiang, Guihong Cao, et al. Xglue: A new benchmark dataset for cross-lingual pre-training, understanding and generation. *arXiv preprint arXiv:2004.01401*, 2020.
1228. Dayiheng Liu, Yu Yan, Yeyun Gong, Weizhen Qi, Hang Zhang, Jian Jiao, Weizhu Chen, Jie Fu, Linjun Shou, Ming Gong, et al. Glge: A new general language generation evaluation benchmark. *arXiv preprint arXiv:2011.11928*, 2020.
1229. Xiangyang Liu, Tianxiang Sun, Junliang He, Lingling Wu, Xinyu Zhang, Hao Jiang, Zhao Cao, Xuanjing Huang, and Xipeng Qiu. Towards efficient nlp: A standard evaluation and a strong baseline. *arXiv preprint arXiv:2110.07038*, 2021.
1230. Kai-Chou Yang, Timothy Niven, and Hung-Yu Kao. Fake news detection as natural language inference. *arXiv preprint arXiv:1907.07347*, 2019.
1231. Mohit Iyyer, Varun Manjunatha, Jordan Boyd-Graber, and Hal Daumé III. Deep unordered composition rivals syntactic methods for text classification. In *Proceedings of the 53rd annual meeting of the association for computational linguistics and the 7th international joint conference on natural language processing (volume 1: Long papers)*, pages 1681–1691, 2015.
1232. Desmond Elliott and Frank Keller. Comparing automatic evaluation measures for image description. In *Proceedings of the 52nd Annual Meeting of the Association for Computational Linguistics (Volume 2: Short Papers)*, pages 452–457, 2014.
1233. Jingjing Xu, Wangchunshu Zhou, Zhiyi Fu, Hao Zhou, and Lei Li. A survey on green deep learning. *arXiv preprint arXiv:2111.05193*, 2021.
1234. Peter F Brown, John Cocke, Stephen A Della Pietra, Vincent J Della Pietra, Frederick Jelinek, John Lafferty, Robert L Mercer, and Paul S Roossin. A statistical approach to machine translation. *Computational linguistics*, 16(2):79–85, 1990.
1235. Philipp Koehn, Franz Josef Och, and Daniel Marcu. Statistical phrase-based translation. In *Proceedings of HLT-NAACL*, pages 127–133, 2003.
1236. Yong Cheng, Wei Xu, Zhongjun He, Wei He, Hua Wu, Maosong Sun, and Yang Liu. Semi-supervised learning for neural machine translation. In *Proceedings of the 54th Annual Meeting of the Association for Computational Linguistics (Volume 1: Long Papers)*, pages 1965–1974, 2016.
1237. Rico Sennrich, Barry Haddow, and Alexandra Birch. Improving neural machine translation models with monolingual data. *arXiv preprint arXiv:1511.06709*, 2015.
1238. Caglar Gulcehre, Orhan Firat, Kelvin Xu, Kyunghyun Cho, Loic Barrault, Huei-Chi Lin, Fethi Bougares, Holger Schwenk, and Yoshua Bengio. On using monolingual corpora in neural machine translation. *arXiv preprint arXiv:1503.03535*, 2015.
1239. Jiajun Zhang and Chengqing Zong. Exploiting source-side monolingual data in neural machine translation. In *Proceedings of the 2016 Conference on Empirical Methods in Natural Language Processing*, pages 1535–1545, 2016.
1240. Kaitao Song, Xu Tan, Tao Qin, Jianfeng Lu, and Tie-Yan Liu. Mass: Masked sequence to sequence pre-training for language generation. In *International Conference on Machine Learning*, pages 5926–5936. PMLR, 2019.
1241. Rongxiang Weng, Heng Yu, Shujian Huang, Shanbo Cheng, and Weihua Luo. Acquiring knowledge from pre-trained model to neural machine translation. In *Proceedings of the AAAI Conference on Artificial Intelligence*, volume 34, pages 9266–9273, 2020.
1242. Jiacheng Yang, Mingxuan Wang, Hao Zhou, Chengqi Zhao, Weinan Zhang, Yong Yu, and Lei Li. Towards making the most of bert in neural machine translation. In *Proceedings of the AAAI Conference on Artificial Intelligence*, volume 34, pages 9378–9385, 2020.
1243. Junliang Guo, Zhirui Zhang, Linli Xu, Hao-Ran Wei, Boxing Chen, and Enhong Chen. Incorporating BERT into Parallel Sequence Decoding with Adapters. In *Advances in Neural Information Processing Systems*, 2020.
1244. Sergey Edunov, Alexei Baevski, and Michael Auli. Pre-trained language model representations for language generation. *arXiv preprint arXiv:1903.09722*, 2019.
1245. Jinhua Zhu, Yingce Xia, Lijun Wu, Di He, Tao Qin, Wengang Zhou, Houqiang Li, and Tie-Yan Liu. Incorporating bert into neural machine translation. *arXiv preprint arXiv:2002.06823*, 2020.
1246. Asa Cooper Stickland, Xian Li, and Marjan Ghazvininejad. Recipes for adapting pre-trained monolingual and multilingual models to machine translation. In *Proceedings of the 16th Conference of the European Chapter of the Association for Computational Linguistics: Main Volume*, pages 3440–3453, 2021.
1247. Jian Yang, Shuming Ma, Dongdong Zhang, Shuangzhi Wu, Zhoujun Li, and Ming Zhou. Alternating language modeling for cross-lingual pre-training. In *Proceedings of the AAAI Conference on Artificial Intelligence*, volume 34, pages 9386–9393, 2020.

1248. Shuming Ma, Jian Yang, Haoyang Huang, Zewen Chi, Li Dong, Dongdong Zhang, Hany Hassan Awadalla, Alexandre Muzio, Akiko Eriguchi, Saksham Singhal, et al. Xlm-t: Scaling up multilingual machine translation with pretrained cross-lingual transformer encoders. *arXiv preprint arXiv:2012.15547*, 2020.
1249. Zhen Yang, Bojie Hu, Ambyera Han, Shen Huang, and Qi Ju. Csp: Code-switching pre-training for neural machine translation. In *Proceedings of the 2020 Conference on Empirical Methods in Natural Language Processing (EMNLP)*, pages 2624–2636, 2020.
1250. Zehui Lin, Xiao Pan, Mingxuan Wang, Xipeng Qiu, Jiangtao Feng, Hao Zhou, and Lei Li. Pre-training multilingual neural machine translation by leveraging alignment information. *arXiv preprint arXiv:2010.03142*, 2020.
1251. Xiao Pan, Mingxuan Wang, Liwei Wu, and Lei Li. Contrastive learning for many-to-many multilingual neural machine translation. *arXiv preprint arXiv:2105.09501*, 2021.
1252. Matthias Sperber and Matthias Paulik. Speech translation and the end-to-end promise: Taking stock of where we are. *arXiv preprint arXiv:2004.06358*, 2020.
1253. Hermann Ney. Speech translation: Coupling of recognition and translation. In *1999 IEEE International Conference on Acoustics, Speech, and Signal Processing. Proceedings. ICASSP99 (Cat. No. 99CH36258)*, volume 1, pages 517–520. IEEE, 1999.
1254. Evgeny Matusov, Stephan Kanthak, and Hermann Ney. On the integration of speech recognition and statistical machine translation. In *Ninth European Conference on Speech Communication and Technology*, 2005.
1255. Lambert Mathias and William Byrne. Statistical phrase-based speech translation. In *2006 IEEE International Conference on Acoustics Speech and Signal Processing Proceedings*, volume 1, pages I–I. IEEE, 2006.
1256. Sameer Bansal, Herman Kamper, Karen Livescu, Adam Lopez, and Sharon Goldwater. Pre-training on high-resource speech recognition improves low-resource speech-to-text translation. *arXiv preprint arXiv:1809.01431*, 2018.
1257. Changhan Wang, Anne Wu, Juan Pino, Alexei Baevski, Michael Auli, and Alexis Conneau. Large-scale self-and semi-supervised learning for speech translation. *arXiv preprint arXiv:2104.06678*, 2021.
1258. Yuchen Liu, Junnan Zhu, Jiajun Zhang, and Chengqing Zong. Bridging the modality gap for speech-to-text translation. *arXiv preprint arXiv:2010.14920*, 2020.
1259. Xian Li, Changhan Wang, Yun Tang, Chau Tran, Yuqing Tang, Juan Pino, Alexei Baevski, Alexis Conneau, and Michael Auli. Multilingual speech translation with efficient finetuning of pretrained models. *arXiv preprint arXiv:2010.12829*, 2020.
1260. Alexandre Bérard, Laurent Besacier, Ali Can Kocabiyikoglu, and Olivier Pietquin. End-to-end automatic speech translation of audiobooks. In *2018 IEEE International Conference on Acoustics, Speech and Signal Processing (ICASSP)*, pages 6224–6228. IEEE, 2018.
1261. Yuchen Liu, Jiajun Zhang, Hao Xiong, Long Zhou, Zhongjun He, Hua Wu, Haifeng Wang, and Chengqing Zong. Synchronous speech recognition and speech-to-text translation with interactive decoding. In *Proceedings of the AAAI Conference on Artificial Intelligence*, volume 34, pages 8417–8424, 2020.
1262. Chengyi Wang, Yu Wu, Shujie Liu, Ming Zhou, and Zhenglu Yang. Curriculum pre-training for end-to-end speech translation. *arXiv preprint arXiv:2004.10093*, 2020.
1263. Ashkan Alinejad and Anoop Sarkar. Effectively pretraining a speech translation decoder with machine translation data. In *Proceedings of the 2020 Conference on Empirical Methods in Natural Language Processing (EMNLP)*, pages 8014–8020, 2020.
1264. Qianqian Dong, Mingxuan Wang, Hao Zhou, Shuang Xu, Bo Xu, and Lei Li. Consecutive decoding for speech-to-text translation. In *The Thirty-fifth AAAI Conference on Artificial Intelligence, AAAI*, 2021.
1265. Yuchen Liu, Hao Xiong, Zhongjun He, Jiajun Zhang, Hua Wu, Haifeng Wang, and Chengqing Zong. End-to-end speech translation with knowledge distillation. *arXiv preprint arXiv:1904.08075*, 2019.
1266. Mihaela C Stoian, Sameer Bansal, and Sharon Goldwater. Analyzing asr pretraining for low-resource speech-to-text translation. In *ICASSP 2020-2020 IEEE International Conference on Acoustics, Speech and Signal Processing (ICASSP)*, pages 7909–7913. IEEE, 2020.
1267. Chengyi Wang, Yu Wu, Shujie Liu, Zhenglu Yang, and Ming Zhou. Bridging the gap between pre-training and fine-tuning for end-to-end speech translation. In *Proceedings of the AAAI Conference on Artificial Intelligence*, volume 34, pages 9161–9168, 2020.
1268. Anne Wu, Changhan Wang, Juan Pino, and Jiatao Gu. Self-supervised representations improve end-to-end speech translation. *arXiv preprint arXiv:2006.12124*, 2020.
1269. Junkun Chen, Mingbo Ma, Renjie Zheng, and Liang Huang. Mam: Masked acoustic modeling for end-to-end speech-to-text translation. *arXiv preprint arXiv:2010.11445*, 2020.
1270. Ha Nguyen, Fethi Bougares, Natalia Tomashenko, Yannick Estève, and Laurent Besacier. Investigating self-supervised pre-training for end-to-end speech translation. In *Interspeech 2020*, 2020.
1271. Steffen Schneider, Alexei Baevski, Ronan Collobert, and Michael Auli. wav2vec: Unsupervised pre-training for speech recognition. *arXiv preprint arXiv:1904.05862*, 2019.
1272. Alexei Baevski, Henry Zhou, Abdelrahman Mohamed, and Michael Auli. wav2vec 2.0: A framework for self-supervised learning of speech representations. *arXiv preprint arXiv:2006.11477*, 2020.
1273. Wei-Ning Hsu, Benjamin Bolte, Yao-Hung Hubert Tsai, Kushal Lakhota, Ruslan Salakhutdinov, and Abdelrahman Mohamed. Hubert: Self-supervised speech representation learning by masked prediction of hidden units. *arXiv preprint arXiv:2106.07447*, 2021.

1274. Sanyuan Chen, Chengyi Wang, Zhengyang Chen, Yu Wu, Shujie Liu, Zhuo Chen, Jinyu Li, Naoyuki Kanda, Takuya Yoshioka, Xiong Xiao, et al. Wavlm: Large-scale self-supervised pre-training for full stack speech processing. *arXiv preprint arXiv:2110.13900*, 2021.
1275. Yu-An Chung, Yu Zhang, Wei Han, Chung-Cheng Chiu, James Qin, Ruoming Pang, and Yonghui Wu. W2v-bert: Combining contrastive learning and masked language modeling for self-supervised speech pre-training. *arXiv preprint arXiv:2108.06209*, 2021.
1276. Yu-An Chung and James Glass. Generative pre-training for speech with autoregressive predictive coding. In *ICASSP 2020-2020 IEEE International Conference on Acoustics, Speech and Signal Processing (ICASSP)*, pages 3497–3501. IEEE, 2020.
1277. Qianqian Dong, Rong Ye, Mingxuan Wang, Hao Zhou, Shuang Xu, Bo Xu, and Lei Li. "listen, understand and translate": Triple supervision decouples end-to-end speech-to-text translation. *arXiv preprint arXiv:2009.09704*, 2020.
1278. Hang Le, Juan Pino, Changhan Wang, Jiatao Gu, Didier Schwab, and Laurent Besacier. Lightweight adapter tuning for multilingual speech translation. *arXiv preprint arXiv:2106.01463*, 2021.
1279. Renjie Zheng, Junkun Chen, Mingbo Ma, and Liang Huang. Fused acoustic and text encoding for multimodal bilingual pretraining and speech translation. *arXiv preprint arXiv:2102.05766*, 2021.
1280. Rong Ye, Mingxuan Wang, and Lei Li. End-to-end speech translation via cross-modal progressive training. *arXiv preprint arXiv:2104.10380*, 2021.
1281. Chen Xu, Bojie Hu, Yanyang Li, Yuhao Zhang, Qi Ju, Tong Xiao, Jingbo Zhu, et al. Stacked acoustic-and-textual encoding: Integrating the pre-trained models into speech translation encoders. *arXiv preprint arXiv:2105.05752*, 2021.
1282. Ankur Bapna, Yu-an Chung, Nan Wu, Anmol Gulati, Ye Jia, Jonathan H Clark, Melvin Johnson, Jason Riesa, Alexis Conneau, and Yu Zhang. Slam: A unified encoder for speech and language modeling via speech-text joint pre-training. *arXiv preprint arXiv:2110.10329*, 2021.
1283. Junyi Ao, Rui Wang, Long Zhou, Shujie Liu, Shuo Ren, Yu Wu, Tom Ko, Qing Li, Yu Zhang, Zhihua Wei, et al. Speecht5: Unified-modal encoder-decoder pre-training for spoken language processing. *arXiv preprint arXiv:2110.07205*, 2021.
1284. Yu-An Chung, Wei-Hung Weng, Schrasing Tong, and James Glass. Towards unsupervised speech-to-text translation. In *ICASSP 2019-2019 IEEE International Conference on Acoustics, Speech and Signal Processing (ICASSP)*, pages 7170–7174. IEEE, 2019.
1285. Ye Jia, Ron J Weiss, Fadi Biadsy, Wolfgang Macherey, Melvin Johnson, Zhifeng Chen, and Yonghui Wu. Direct speech-to-speech translation with a sequence-to-sequence model. *arXiv preprint arXiv:1904.06037*, 2019.
1286. Ye Jia, Michelle Tadmor Ramanovich, Tal Remez, and Roi Pomerantz. Translatotron 2: Robust direct speech-to-speech translation. *arXiv preprint arXiv:2107.08661*, 2021.
1287. Xiang Li, Haiyang Xue, Wei Chen, Yang Liu, Yang Feng, and Qun Liu. Improving the robustness of speech translation. *arXiv preprint arXiv:1811.00728*, 2018.
1288. Giuseppe Martucci, Mauro Cettolo, Matteo Negri, and Marco Turchi. Lexical modeling of asr errors for robust speech translation. *Proc. Interspeech 2021*, pages 2282–2286, 2021.
1289. Hirofumi Inaguma, Kevin Duh, Tatsuya Kawahara, and Shinji Watanabe. Multilingual end-to-end speech translation. In *2019 IEEE Automatic Speech Recognition and Understanding Workshop (ASRU)*, pages 570–577. IEEE, 2019.
1290. Xutai Ma, Yongqiang Wang, Mohammad Javad Dousti, Philipp Koehn, and Juan Pino. Streaming simultaneous speech translation with augmented memory transformer. In *ICASSP 2021-2021 IEEE International Conference on Acoustics, Speech and Signal Processing (ICASSP)*, pages 7523–7527. IEEE, 2021.
1291. Eugene Kharitonov, Ann Lee, Adam Polyak, Yossi Adi, Jade Copet, Kushal Lakhota, Tu-Anh Nguyen, Morgane Rivière, Abdelrahman Mohamed, Emmanuel Dupoux, et al. Text-free prosody-aware generative spoken language modeling. *arXiv preprint arXiv:2109.03264*, 2021.
1292. Junkun Chen, Mingbo Ma, Renjie Zheng, and Liang Huang. Direct simultaneous speech-to-text translation assisted by synchronized streaming asr. *arXiv preprint arXiv:2106.06636*, 2021.
1293. Alexei Baevski, Wei-Ning Hsu, Alexis Conneau, and Michael Auli. Unsupervised speech recognition. *arXiv preprint arXiv:2105.11084*, 2021.
1294. Matthew Snover, Bonnie Dorr, Richard Schwartz, Linnea Micciulla, and John Makhoul. A study of translation edit rate with targeted human annotation. In *Proceedings of the 7th Conference of the Association for Machine Translation in the Americas: Technical Papers*, pages 223–231, 2006.
1295. Tianyi Zhang, Varsha Kishore, Felix Wu, Kilian Q Weinberger, and Yoav Artzi. Bertscore: Evaluating text generation with bert. In *International Conference on Learning Representations*, 2019.
1296. Chi-kiu Lo. Meant 2.0: Accurate semantic mt evaluation for any output language. In *Proceedings of the second conference on machine translation*, pages 589–597, 2017.
1297. Chi-kiu Lo. Yisi-a unified semantic mt quality evaluation and estimation metric for languages with different levels of available resources. In *Proceedings of the Fourth Conference on Machine Translation (Volume 2: Shared Task Papers, Day 1)*, pages 507–513, 2019.
1298. Thibault Sellam, Amy Pu, Hyung Won Chung, Sebastian Gehrmann, Qijun Tan, Markus Freitag, Dipanjan Das, and Ankur Parikh. Learning to evaluate translation beyond English: BLEURT submissions to the WMT metrics 2020 shared task. In *Proceedings of the Fifth Conference on Machine Translation*, pages 921–927, Online, November 2020. Association for Computational Linguistics.
1299. Hassan Kane, Muhammed Yusuf Kocyigit, Ali Abdalla, Pelkins Ajanoh, and Mohamed Coulibali. Nubia: Neural based interchangeability assessor for text generation. In *Proceedings of the 1st Workshop on Evaluating NLG Evaluation*, pages 28–37, 2020.

1300. Yimeng Chen, Yanyan Lan, Ruibin Xiong, Liang Pang, Zhiming Ma, and Xueqi Cheng. Evaluating natural language generation via unbalanced optimal transport. In *IJCAI*, pages 3730–3736, 2020.
1301. Ruibo Liu, Jason Wei, and Soroush Vosoughi. Language model augmented relevance score. *arXiv preprint arXiv:2108.08485*, 2021.
1302. Jialun Cao, Meiziniu Li, Yeting Li, Ming Wen, and Shing-Chi Cheung. Semmt: A semantic-based testing approach for machine translation systems. *arXiv preprint arXiv:2012.01815*, 2020.
1303. Zorik Gekhman, Roei Aharoni, Genady Beryozkin, Markus Freitag, and Wolfgang Macherey. Kobe: Knowledge-based machine translation evaluation. In *Proceedings of the 2020 Conference on Empirical Methods in Natural Language Processing: Findings*, pages 3200–3207, 2020.
1304. Zhaopeng Tu, Zhengdong Lu, Yang Liu, Xiaohua Liu, and Hang Li. Modeling coverage for neural machine translation. In *Proceedings of the 54th Annual Meeting of the Association for Computational Linguistics (Volume 1: Long Papers)*, August 2016.
1305. Shuo Wang, Zhaopeng Tu, Shuming Shi, and Yang Liu. On the inference calibration of neural machine translation. In *Proceedings of the 58th Annual Meeting of the Association for Computational Linguistics*, 2020.
1306. Yurun Song, Junchen Zhao, and Lucia Specia. Sentsim: Crosslingual semantic evaluation of machine translation. In *Proceedings of the 2021 Conference of the North American Chapter of the Association for Computational Linguistics: Human Language Technologies*, pages 3143–3156, 2021.
1307. Jingyi Zhang and Josef van Genabith. Translation quality estimation by jointly learning to score and rank. In *Proceedings of the 2020 Conference on Empirical Methods in Natural Language Processing (EMNLP)*, pages 2592–2598, 2020.
1308. Jihyung Moon, Hyunchang Cho, and Eunjeong L Park. Revisiting round-trip translation for quality estimation. *arXiv preprint arXiv:2004.13937*, 2020.
1309. Wei Zhao, Goran Glavaš, Maxime Peyrard, Yang Gao, Robert West, and Steffen Eger. On the limitations of cross-lingual encoders as exposed by reference-free machine translation evaluation. *arXiv preprint arXiv:2005.01196*, 2020.
1310. Shuo Wang, Zhaopeng Tu, Zhixing Tan, Shuming Shi, Maosong Sun, and Yang Liu. On the language coverage bias for neural machine translation. *arXiv preprint arXiv:2106.03297*, 2021.
1311. Sweta Agrawal, George Foster, Markus Freitag, and Colin Cherry. Assessing reference-free peer evaluation for machine translation. In *Proceedings of the 2021 Conference of the North American Chapter of the Association for Computational Linguistics: Human Language Technologies*, pages 1158–1171, 2021.
1312. Stephan Busemann and Helmut Horacek. A flexible shallow approach to text generation. *arXiv preprint cs/9812018*, 1998.
1313. Michael White and Ted Caldwell. Exemplars: A practical, extensible framework for dynamic text generation. In *Natural Language Generation*, 1998.
1314. Eli Goldberg, Norbert Driedger, and Richard I Kittredge. Using natural-language processing to produce weather forecasts. *IEEE Expert*, 9(2):45–53, 1994.
1315. Ehud Reiter and Robert Dale. Building applied natural language generation systems. *Natural Language Engineering*, 3(1):57–87, 1997.
1316. Irene Langkilde and Kevin Knight. Generation that exploits corpus-based statistical knowledge. In *COLING 1998 Volume 1: The 17th International Conference on Computational Linguistics*, 1998.
1317. Alice Oh and Alexander Rudnicky. Stochastic language generation for spoken dialogue systems. In *ANLP-NAACL 2000 Workshop: Conversational Systems*, 2000.
1318. François Mairesse, Milica Gasic, Filip Jurcicek, Simon Keizer, Blaise Thomson, Kai Yu, and Steve Young. Phrase-based statistical language generation using graphical models and active learning. In *Proceedings of the 48th Annual Meeting of the Association for Computational Linguistics*, pages 1552–1561, 2010.
1319. Daniel Paiva and Roger Evans. Empirically-based control of natural language generation. In *Proceedings of the 43rd Annual Meeting of the Association for Computational Linguistics (ACL'05)*, pages 58–65, 2005.
1320. Christina Sauper and Regina Barzilay. Automatically generating wikipedia articles: A structure-aware approach. In *Proceedings of the Joint Conference of the 47th Annual Meeting of the ACL and the 4th International Joint Conference on Natural Language Processing of the AFNLP*, pages 208–216, 2009.
1321. Jiatao Gu, James Bradbury, Caiming Xiong, Victor OK Li, and Richard Socher. Non-autoregressive neural machine translation. In *International Conference on Learning Representations*, 2018.
1322. Raman Chandrasekar, Christine Doran, and Srinivas Bangalore. Motivations and methods for text simplification. In *COLING 1996 Volume 2: The 16th International Conference on Computational Linguistics*, 1996.
1323. Sergiu Nisoi, Sanja Štajner, Simone Paolo Ponzetto, and Liviu P Dinu. Exploring neural text simplification models. In *Proceedings of the 55th annual meeting of the association for computational linguistics (volume 2: Short papers)*, pages 85–91, 2017.
1324. Advait Siddharthan. A survey of research on text simplification. *ITL-International Journal of Applied Linguistics*, 165(2):259–298, 2014.
1325. Siobhan Lucy Devlin. *Simplifying natural language for aphasic readers*. PhD thesis, University of Sunderland, 1999.
1326. Advait Siddharthan. Syntactic simplification and text cohesion. *Research on Language and Computation*, 4(1):77–109, 2006.
1327. Sasikiran Kandula, Dorothy Curtis, and Qing Zeng-Treitler. A semantic and syntactic text simplification tool for health content. In *AMIA annual symposium proceedings*, volume 2010, page 366. American Medical Informatics Association, 2010.



1328. Regina Barzilay and Lillian Lee. Learning to paraphrase: An unsupervised approach using multiple-sequence alignment. *arXiv preprint cs/0304006*, 2003.
1329. Bo Pang, Kevin Knight, and Daniel Marcu. Syntax-based alignment of multiple translations: Extracting paraphrases and generating new sentences. In *Proceedings of the 2003 Human Language Technology Conference of the North American Chapter of the Association for Computational Linguistics*, pages 181–188, 2003.
1330. Colin Bannard and Chris Callison-Burch. Paraphrasing with bilingual parallel corpora. In *Proceedings of the 43rd Annual Meeting of the Association for Computational Linguistics (ACL'05)*, pages 597–604, 2005.
1331. Anthony Fader, Luke Zettlemoyer, and Oren Etzioni. Open question answering over curated and extracted knowledge bases. In *Proceedings of the 20th ACM SIGKDD international conference on Knowledge discovery and data mining*, pages 1156–1165, 2014.
1332. Peter W Culicover. Paraphrase generation and information retrieval from stored text. *Mech. Transl. Comput. Linguistics*, 11(3-4):78–88, 1968.
1333. Shailza Jolly, Tobias Falke, Caglar Tirkaz, and Daniil Sorokin. Data-efficient paraphrase generation to bootstrap intent classification and slot labeling for new features in task-oriented dialog systems. In *Proceedings of the 28th International Conference on Computational Linguistics: Industry Track*, pages 10–20, 2020.
1334. Tianxiao Shen, Tao Lei, Regina Barzilay, and Tommi Jaakkola. Style transfer from non-parallel text by cross-alignment. *arXiv preprint arXiv:1705.09655*, 2017.
1335. Zichao Yang, Zhiting Hu, Chris Dyer, Eric P Xing, and Taylor Berg-Kirkpatrick. Unsupervised text style transfer using language models as discriminators. In *Proceedings of the 32nd International Conference on Neural Information Processing Systems*, pages 7298–7309, 2018.
1336. Zhenxin Fu, Xiaoye Tan, Nanyun Peng, Dongyan Zhao, and Rui Yan. Style transfer in text: Exploration and evaluation. In *Proceedings of the AAAI Conference on Artificial Intelligence*, volume 32, 2018.
1337. Beth Davey and Susan McBride. Effects of question-generation training on reading comprehension. *Journal of Educational Psychology*, 78(4):256, 1986.
1338. Xinya Du, Junru Shao, and Claire Cardie. Learning to ask: Neural question generation for reading comprehension. *arXiv preprint arXiv:1705.00106*, 2017.
1339. Nan Duan, Duyu Tang, Peng Chen, and Ming Zhou. Question generation for question answering. In *Proceedings of the 2017 Conference on Empirical Methods in Natural Language Processing*, pages 866–874, 2017.
1340. Michele Banko, Vibhu O Mittal, and Michael J Witbrock. Headline generation based on statistical translation. In *Proceedings of the 38th Annual Meeting of the Association for Computational Linguistics*, pages 318–325, 2000.
1341. Jiwei Tan, Xiaojun Wan, and Jianguo Xiao. From neural sentence summarization to headline generation: A coarse-to-fine approach. In *IJCAI*, volume 17, pages 4109–4115, 2017.
1342. Ruqing Zhang, Jiafeng Guo, Yixing Fan, Yanyan Lan, Jun Xu, Huanhuan Cao, and Xueqi Cheng. Question headline generation for news articles. In *Proceedings of the 27th ACM international conference on information and knowledge management*, pages 617–626, 2018.
1343. Yun-Gyung Cheong and R Michael Young. Narrative generation for suspense: Modeling and evaluation. In *Joint International Conference on Interactive Digital Storytelling*, pages 144–155. Springer, 2008.
1344. Julie Porteous and Marc Cavazza. Controlling narrative generation with planning trajectories: the role of constraints. In *Joint International Conference on Interactive Digital Storytelling*, pages 234–245. Springer, 2009.
1345. Julie Porteous, Marc Cavazza, and Fred Charles. Narrative generation through characters’ point of view. In *AAMAS*, pages 1297–1304. Citeseer, 2010.
1346. Simon Colton, Jacob Goodwin, and Tony Veale. Full-face poetry generation. In *ICCC*, pages 95–102, 2012.
1347. Marjan Ghazvininejad, Xing Shi, Jay Priyadarshi, and Kevin Knight. Hafez: an interactive poetry generation system. In *Proceedings of ACL 2017, System Demonstrations*, pages 43–48, 2017.
1348. Xingxing Zhang and Mirella Lapata. Chinese poetry generation with recurrent neural networks. In *Proceedings of the 2014 Conference on Empirical Methods in Natural Language Processing (EMNLP)*, pages 670–680, 2014.
1349. Li Dong, Shaohan Huang, Furu Wei, Mirella Lapata, Ming Zhou, and Ke Xu. Learning to generate product reviews from attributes. In *Proceedings of the 15th Conference of the European Chapter of the Association for Computational Linguistics: Volume 1, Long Papers*, pages 623–632, 2017.
1350. Jianmo Ni, Zachary C Lipton, Sharad Vikram, and Julian McAuley. Estimating reactions and recommending products with generative models of reviews. In *Proceedings of the Eighth International Joint Conference on Natural Language Processing (Volume 1: Long Papers)*, pages 783–791, 2017.
1351. Qingyun Wang, Qi Zeng, Lifu Huang, Kevin Knight, Heng Ji, and Nazneen Fatema Rajani. Reviewrobot: Explainable paper review generation based on knowledge synthesis. *arXiv preprint arXiv:2010.06119*, 2020.
1352. Junnan Zhu, Qian Wang, Yining Wang, Yu Zhou, Jiajun Zhang, Shaonan Wang, and Chengqing Zong. Ncls: Neural cross-lingual summarization. *arXiv preprint arXiv:1909.00156*, 2019.
1353. Yue Cao, Hui Liu, and Xiaojun Wan. Jointly learning to align and summarize for neural cross-lingual summarization. In *Proceedings of the 58th Annual Meeting of the Association for Computational Linguistics*, pages 6220–6231, 2020.
1354. Junwei Bao, Duyu Tang, Nan Duan, Zhao Yan, Yuanhua Lv, Ming Zhou, and Tiejun Zhao. Table-to-text: Describing table region with natural language. In *Thirty-Second AAAI Conference on Artificial Intelligence*, 2018.
1355. Panupong Pasupat and Percy Liang. Compositional semantic parsing on semi-structured tables. In *Proceedings of the 53rd Annual Meeting of the Association for Computational Linguistics and the 7th International Joint Conference on Natural Language Processing (Volume 1: Long Papers)*, pages 1470–1480, 2015.

1356. Huan Sun, Hao Ma, Xiaodong He, Wen-tau Yih, Yu Su, and Xifeng Yan. Table cell search for question answering. In *Proceedings of the 25th International Conference on World Wide Web*, pages 771–782, 2016.
1357. Paweł Budzianowski, Tsung-Hsien Wen, Bo-Hsiang Tseng, Iñigo Casanueva, Stefan Ultes, Osman Ramadan, and Milica Gasic. Multiwoz-a large-scale multi-domain wizard-of-oz dataset for task-oriented dialogue modelling. In *Proceedings of the 2018 Conference on Empirical Methods in Natural Language Processing*, pages 5016–5026, 2018.
1358. Amanda Stent, Rashmi Prasad, and Marilyn Walker. Trainable sentence planning for complex information presentations in spoken dialog systems. In *Proceedings of the 42nd Annual Meeting of the Association for Computational Linguistics (ACL-04)*, pages 79–86, 2004.
1359. Marilyn A Walker, Amanda Stent, François Mairesse, and Rashmi Prasad. Individual and domain adaptation in sentence planning for dialogue. *Journal of Artificial Intelligence Research*, 30:413–456, 2007.
1360. Tsung-Hsien Wen, Milica Gasic, Nikola Mrkšić, Pei-Hao Su, David Vandyke, and Steve Young. Semantically conditioned lstm-based natural language generation for spoken dialogue systems. In *Proceedings of the 2015 Conference on Empirical Methods in Natural Language Processing*, pages 1711–1721, 2015.
1361. Xiaochang Peng, Chuan Wang, Daniel Gildea, and Nianwen Xue. Addressing the data sparsity issue in neural amr parsing. In *Proceedings of the 15th Conference of the European Chapter of the Association for Computational Linguistics: Volume 1, Long Papers*, pages 366–375, 2017.
1362. Laura Perez-Beltrachini and Mirella Lapata. Bootstrapping generators from noisy data. In *Proceedings of the 2018 Conference of the North American Chapter of the Association for Computational Linguistics: Human Language Technologies, Volume 1 (Long Papers)*, pages 1516–1527, 2018.
1363. Liunian Li and Xiaojun Wan. Point precisely: Towards ensuring the precision of data in generated texts using delayed copy mechanism. In *Proceedings of the 27th International Conference on Computational Linguistics*, pages 1044–1055, 2018.
1364. Tianyu Liu, Kexiang Wang, Lei Sha, Baobao Chang, and Zhifang Sui. Table-to-text generation by structure-aware seq2seq learning. In *Thirty-Second AAAI Conference on Artificial Intelligence*, 2018.
1365. Marco Roberti, Giovanni Bonetta, Rossella Cancelliere, Gallinari Patrick, et al. Copy mechanism and tailored training for character-based data-to-text generation. In *ECML PKDD 2019-European Conference on Machine Learning and Principles and Practice of Knowledge Discovery in Databases*, pages 1–16. Springer, 2019.
1366. C Rebuffel, L Soulier, G Scoutheeten, and P Gallinari. A hierarchical model for data-to-text generation. *Advances in Information Retrieval*, 12035:65–80, 2020.
1367. Hamza Harkous, Isabel Groves, and Amir Saffari. Have your text and use it too! end-to-end neural data-to-text generation with semantic fidelity. In *Proceedings of the 28th International Conference on Computational Linguistics*, pages 2410–2424, 2020.
1368. Mihir Kale and Abhinav Rastogi. Text-to-text pre-training for data-to-text tasks. In *Proceedings of the 13th International Conference on Natural Language Generation*, pages 97–102, 2020.
1369. Leonardo FR Ribeiro, Martin Schmitt, Hinrich Schütze, and Iryna Gurevych. Investigating pretrained language models for graph-to-text generation. *arXiv preprint arXiv:2007.08426*, 2020.
1370. Xiang Deng, Ahmed Hassan, Christopher Meek, Oleksandr Polozov, Huan Sun, and Matthew Richardson. Structure-grounded pretraining for text-to-sql. In *Proceedings of the 2021 Conference of the North American Chapter of the Association for Computational Linguistics: Human Language Technologies*, pages 1337–1350, 2021.
1371. Pengcheng Yin, Graham Neubig, Wen-tau Yih, and Sebastian Riedel. Tabert: Pretraining for joint understanding of textual and tabular data. In *Proceedings of the 58th Annual Meeting of the Association for Computational Linguistics*, pages 8413–8426, 2020.
1372. Liang Li, Can Ma, Yinliang Yue, Linjun Shou, and Dayong Hu. Learning better representation for tables by self-supervised tasks. *arXiv preprint arXiv:2010.07606*, 2020.
1373. Xinyu Xing and Xiaojun Wan. Structure-aware pre-training for table-to-text generation. In *Findings of the Association for Computational Linguistics: ACL-IJCNLP 2021*, pages 2273–2278, 2021.
1374. Ioannis Konstas, Srinivasan Iyer, Mark Yatskar, Yejin Choi, and Luke Zettlemoyer. Neural amr: Sequence-to-sequence models for parsing and generation. In *Proceedings of the 55th Annual Meeting of the Association for Computational Linguistics (Volume 1: Long Papers)*, pages 146–157, 2017.
1375. Bayu Distiawan, Jianzhong Qi, Rui Zhang, and Wei Wang. Gtr-lstm: A triple encoder for sentence generation from rdf data. In *Proceedings of the 56th Annual Meeting of the Association for Computational Linguistics (Volume 1: Long Papers)*, pages 1627–1637, 2018.
1376. Amit Moryossef, Yoav Goldberg, and Ido Dagan. Step-by-step: Separating planning from realization in neural data-to-text generation. In *Proceedings of the 2019 Conference of the North American Chapter of the Association for Computational Linguistics: Human Language Technologies, Volume 1 (Long and Short Papers)*, pages 2267–2277, 2019.
1377. Thiago Castro Ferreira, Chris van der Lee, Emiel Van Miltenburg, and Emiel Krahmer. Neural data-to-text generation: A comparison between pipeline and end-to-end architectures. In *Proceedings of the 2019 Conference on Empirical Methods in Natural Language Processing and the 9th International Joint Conference on Natural Language Processing (EMNLP-IJCNLP)*, pages 552–562, 2019.
1378. Leonardo FR Ribeiro, Jonas Pfeiffer, Yue Zhang, and Iryna Gurevych. Smelting gold and silver for improved multilingual amr-to-text generation. In *Proceedings of the 2021 Conference on Empirical Methods in Natural Language Processing*, pages 742–750, 2021.

1379. Diego Marcheggiani and Laura Perez-Beltrachini. Deep graph convolutional encoders for structured data to text generation. In *Proceedings of the 11th International Conference on Natural Language Generation*, pages 1–9, 2018.
1380. Linfeng Song, Yue Zhang, Zhiguo Wang, and Daniel Gildea. A graph-to-sequence model for amr-to-text generation. In *Proceedings of the 56th Annual Meeting of the Association for Computational Linguistics (Volume 1: Long Papers)*, pages 1616–1626, 2018.
1381. Daniel Beck, Gholamreza Haffari, and Trevor Cohn. Graph-to-sequence learning using gated graph neural networks. In *Proceedings of the 56th Annual Meeting of the Association for Computational Linguistics (Volume 1: Long Papers)*, pages 273–283, 2018.
1382. Marco Damonte and Shay B Cohen. Structural neural encoders for amr-to-text generation. In *Proceedings of the 2019 Conference of the North American Chapter of the Association for Computational Linguistics: Human Language Technologies, Volume 1 (Long and Short Papers)*, pages 3649–3658, 2019.
1383. Leonardo FR Ribeiro, Claire Gardent, and Iryna Gurevych. Enhancing amr-to-text generation with dual graph representations. In *Proceedings of the 2019 Conference on Empirical Methods in Natural Language Processing and the 9th International Joint Conference on Natural Language Processing (EMNLP-IJCNLP)*, pages 3183–3194, 2019.
1384. Chao Zhao, Marilyn Walker, and Snigdha Chaturvedi. Bridging the structural gap between encoding and decoding for data-to-text generation. In *Proceedings of the 58th Annual Meeting of the Association for Computational Linguistics*, pages 2481–2491, 2020.
1385. Martin Schmitt, Leonardo FR Ribeiro, Philipp Dufter, Iryna Gurevych, and Hinrich Schütze. Modeling graph structure via relative position for text generation from knowledge graphs. In *Proceedings of the Fifteenth Workshop on Graph-Based Methods for Natural Language Processing (TextGraphs-15)*, pages 10–21, 2021.
1386. Leonardo FR Ribeiro, Yue Zhang, and Iryna Gurevych. Structural adapters in pretrained language models for amr-to-text generation. *arXiv preprint arXiv:2103.09120*, 2021.
1387. Leonardo FR Ribeiro, Yue Zhang, Claire Gardent, and Iryna Gurevych. Modeling global and local node contexts for text generation from knowledge graphs. *Transactions of the Association for Computational Linguistics*, 8:589–604, 2020.
1388. Shaowei Yao, Tianming Wang, and Xiaojun Wan. Heterogeneous graph transformer for graph-to-sequence learning. In *Proceedings of the 58th Annual Meeting of the Association for Computational Linguistics*, pages 7145–7154, 2020.
1389. Tianming Wang, Xiaojun Wan, and Hanqi Jin. Amr-to-text generation with graph transformer. *Transactions of the Association for Computational Linguistics*, 8:19–33, 2020.
1390. Manuel Mager, Ramón Fernández Astudillo, Tahira Naseem, Md Arafat Sultan, Young-Suk Lee, Radu Florian, and Salim Roukos. Gpt-too: A language-model-first approach for amr-to-text generation. In *Proceedings of the 58th Annual Meeting of the Association for Computational Linguistics*, pages 1846–1852, 2020.
1391. Alexander Hoyle, Ana Marasović, and Noah Smith. Promoting graph awareness in linearized graph-to-text generation. *arXiv preprint arXiv:2012.15793*, 2020.
1392. Junhua Mao, Wei Xu, Yi Yang, Jiang Wang, and Alan L Yuille. Explain images with multimodal recurrent neural networks. *arXiv preprint arXiv:1410.1090*, 2014.
1393. Andrej Karpathy and Li Fei-Fei. Deep visual-semantic alignments for generating image descriptions. In *Proceedings of the IEEE conference on computer vision and pattern recognition*, pages 3128–3137, 2015.
1394. Ting Yao, Yingwei Pan, Yehao Li, Zhaofan Qiu, and Tao Mei. Boosting image captioning with attributes. In *Proceedings of the IEEE international conference on computer vision*, pages 4894–4902, 2017.
1395. Ting Yao, Yingwei Pan, Yehao Li, and Tao Mei. Exploring visual relationship for image captioning. In *Proceedings of the European conference on computer vision (ECCV)*, pages 684–699, 2018.
1396. Ting Yao, Yingwei Pan, Yehao Li, and Tao Mei. Hierarchy parsing for image captioning. In *Proceedings of the IEEE/CVF International Conference on Computer Vision*, pages 2621–2629, 2019.
1397. Yingwei Pan, Tao Mei, Ting Yao, Houqiang Li, and Yong Rui. Jointly modeling embedding and translation to bridge video and language. In *Proceedings of the IEEE conference on computer vision and pattern recognition*, pages 4594–4602, 2016.
1398. Subhashini Venugopalan, Marcus Rohrbach, Jeffrey Donahue, Raymond Mooney, Trevor Darrell, and Kate Saenko. Sequence to sequence-video to text. In *Proceedings of the IEEE international conference on computer vision*, pages 4534–4542, 2015.
1399. Subhashini Venugopalan, Huijuan Xu, Jeff Donahue, Marcus Rohrbach, Raymond Mooney, and Kate Saenko. Translating videos to natural language using deep recurrent neural networks. In *Proceedings of the 2015 Conference of the North American Chapter of the Association for Computational Linguistics: Human Language Technologies*, pages 1494–1504, 2015.
1400. Yingwei Pan, Ting Yao, Houqiang Li, and Tao Mei. Video captioning with transferred semantic attributes. In *Proceedings of the IEEE conference on computer vision and pattern recognition*, pages 6504–6512, 2017.
1401. Lun Huang, Wenmin Wang, Jie Chen, and Xiao-Yong Wei. Attention on attention for image captioning. In *ICCV*, 2019.
1402. Marcella Cornia, Matteo Stefanini, Lorenzo Baraldi, and Rita Cucchiara. Meshed-memory transformer for image captioning. In *CVPR*, 2020.
1403. Yingwei Pan, Ting Yao, Yehao Li, and Tao Mei. X-linear attention networks for image captioning. In *Proceedings of the IEEE/CVF Conference on Computer Vision and Pattern Recognition*, pages 10971–10980, 2020.
1404. Simao Herdade, Armin Kappeler, Kofi Boakye, and Joao Soares. Image captioning: Transforming objects into words. *Advances in Neural Information Processing Systems*, 32:11137–11147, 2019.

1405. Luwei Zhou, Yingbo Zhou, Jason J Corso, Richard Socher, and Caiming Xiong. End-to-end dense video captioning with masked transformer. In *Proceedings of the IEEE Conference on Computer Vision and Pattern Recognition*, pages 8739–8748, 2018.
1406. Luwei Zhou, Hamid Palangi, Lei Zhang, Houdong Hu, Jason Corso, and Jianfeng Gao. Unified vision-language pre-training for image captioning and vqa. In *Proceedings of the AAAI Conference on Artificial Intelligence*, volume 34, pages 13041–13049, 2020.
1407. Yehao Li, Yingwei Pan, Ting Yao, Jingwen Chen, and Tao Mei. Scheduled sampling in vision-language pretraining with decoupled encoder-decoder network. In *Proceedings of the AAAI Conference on Artificial Intelligence*, volume 35, pages 8518–8526, 2021.
1408. Linjie Li, Yen-Chun Chen, Yu Cheng, Zhe Gan, Licheng Yu, and Jingjing Liu. Hero: Hierarchical encoder for video+ language omni-representation pre-training. In *Proceedings of the 2020 Conference on Empirical Methods in Natural Language Processing (EMNLP)*, pages 2046–2065, 2020.
1409. Jianjie Luo, Yehao Li, Yingwei Pan, Ting Yao, Hongyang Chao, and Tao Mei. Coco-bert: Improving video-language pre-training with contrastive cross-modal matching and denoising. In *Proceedings of the 29th ACM International Conference on Multimedia*, pages 5600–5608, 2021.
1410. Yingwei Pan, Yehao Li, Jianjie Luo, Jun Xu, Ting Yao, and Tao Mei. Auto-captions on gif: A large-scale video-sentence dataset for vision-language pre-training. *arXiv preprint arXiv:2007.02375*, 2020.
1411. Jiatao Gu, Qi Liu, and Kyunghyun Cho. Insertion-based decoding with automatically inferred generation order. *Transactions of the Association for Computational Linguistics*, 7:661–676, 2019.
1412. Mitchell Stern, William Chan, Jamie Kiros, and Jakob Uszkoreit. Insertion transformer: Flexible sequence generation via insertion operations. In *International Conference on Machine Learning*, pages 5976–5985. PMLR, 2019.
1413. Yixuan Su, Deng Cai, Yan Wang, David Vandyke, Simon Baker, Piji Li, and Nigel Collier. Non-autoregressive text generation with pre-trained language models. *arXiv preprint arXiv:2102.08220*, 2021.
1414. Ruizhen Qi, Yeyun Gong, Jian Jiao, Yu Yan, Weizhu Chen, Dayiheng Liu, Kewen Tang, Houqiang Li, Jiusheng Chen, Ruofei Zhang, et al. Bang: Bridging autoregressive and non-autoregressive generation with large scale pretraining. In *International Conference on Machine Learning*, pages 8630–8639. PMLR, 2021.
1415. Hao Tian, Can Gao, Xinyan Xiao, Hao Liu, Bolei He, Hua Wu, Haifeng Wang, and Feng Wu. Skip: Sentiment knowledge enhanced pre-training for sentiment analysis. In *Proceedings of the 58th Annual Meeting of the Association for Computational Linguistics*, pages 4067–4076, 2020.
1416. Jessica Fidler and Yoav Goldberg. Controlling linguistic style aspects in neural language generation. In *Proceedings of the Workshop on Stylistic Variation*, pages 94–104, 2017.
1417. Yuta Kikuchi, Graham Neubig, Ryohei Sasano, Hiroya Takamura, and Manabu Okumura. Controlling output length in neural encoder-decoders. In *Proceedings of the 2016 Conference on Empirical Methods in Natural Language Processing*, pages 1328–1338, 2016.
1418. Shrimai Prabhunoye, Chris Quirk, and Michel Galley. Towards content transfer through grounded text generation. *arXiv preprint arXiv:1905.05293*, 2019.
1419. Junxian He, Wojciech Kryściński, Bryan McCann, Nazneen Rajani, and Caiming Xiong. Ctrlsum: Towards generic controllable text summarization. *arXiv preprint arXiv:2012.04281*, 2020.
1420. Reinald Kim Amplayo and Mirella Lapata. Informative and controllable opinion summarization. In *Proceedings of the 16th Conference of the European Chapter of the Association for Computational Linguistics: Main Volume*, pages 2662–2672, 2021.
1421. Hao Zhou, Minlie Huang, Tianyang Zhang, Xiaoyan Zhu, and Bing Liu. Emotional chatting machine: Emotional conversation generation with internal and external memory. In *Thirty-Second AAAI Conference on Artificial Intelligence*, 2018.
1422. Zhenqiao Song, Xiaoqing Zheng, Lu Liu, Mu Xu, and Xuan-Jing Huang. Generating responses with a specific emotion in dialog. In *Proceedings of the 57th Annual Meeting of the Association for Computational Linguistics*, pages 3685–3695, 2019.
1423. Pierre Colombo, Wojciech Witon, Ashutosh Modi, James Kennedy, and Mubbasir Kapadia. Affect-driven dialog generation. *arXiv preprint arXiv:1904.02793*, 2019.
1424. Nanyun Peng, Marjan Ghazvininejad, Jonathan May, and Kevin Knight. Towards controllable story generation. In *Proceedings of the First Workshop on Storytelling*, pages 43–49, 2018.
1425. Pradyumna Tambwekar, Murtaza Dhuliawala, Lara J Martin, Animesh Mehta, Brent Harrison, and Mark O Riedl. Controllable neural story plot generation via reinforcement learning. *arXiv preprint arXiv:1809.10736*, 2018.
1426. Sumanth Dathathri, Andrea Madotto, Janice Lan, Jane Hung, Eric Frank, Piero Molino, Jason Yosinski, and Rosanne Liu. Plug and play language models: A simple approach to controlled text generation. *arXiv preprint arXiv:1912.02164*, 2019.
1427. Raul Puri and Bryan Catanzaro. Zero-shot text classification with generative language models. *arXiv preprint arXiv:1912.10165*, 2019.
1428. Xiang Chen, Xin Xie, Ningyu Zhang, Jiahuan Yan, Shumin Deng, Chuanqi Tan, Fei Huang, Luo Si, and Huajun Chen. Adaprompt: Adaptive prompt-based finetuning for relation extraction. *arXiv preprint arXiv:2104.07650*, 2021.
1429. Leyang Cui, Yu Wu, Jian Liu, Sen Yang, and Yue Zhang. Template-based named entity recognition using bart. *arXiv preprint arXiv:2106.01760*, 2021.

1430. Minlie Huang, Xiaoyan Zhu, and Jianfeng Gao. Challenges in building intelligent open-domain dialog systems. *ACM Transactions on Information Systems (TOIS)*, 38(3):1–32, 2020.
1431. Qingyang Wu, Yichi Zhang, Yu Li, and Zhou Yu. Alternating roles dialog model with large-scale pre-trained language models. *arXiv preprint arXiv:1910.03756*, 2019.
1432. Jiwei Li, Michel Galley, Chris Brockett, Jianfeng Gao, and Bill Dolan. A diversity-promoting objective function for neural conversation models. *arXiv preprint arXiv:1510.03055*, 2015.
1433. Saizheng Zhang, Emily Dinan, Jack Urbanek, Arthur Szlam, Douwe Kiela, and Jason Weston. Personalizing dialogue agents: I have a dog, do you have pets too? In *Proceedings of the 56th Annual Meeting of the Association for Computational Linguistics (Volume 1: Long Papers)*, pages 2204–2213, 2018.
1434. Esteban Real, Alok Aggarwal, Yanping Huang, and Quoc V Le. Regularized evolution for image classifier architecture search. In *Proceedings of the aaai conference on artificial intelligence*, volume 33, pages 4780–4789, 2019.
1435. Hannah Rashkin, Eric Michael Smith, Margaret Li, and Y-Lan Boureau. Towards empathetic open-domain conversation models: A new benchmark and dataset. In *Proceedings of the 57th Annual Meeting of the Association for Computational Linguistics*, pages 5370–5381, 2019.
1436. Emily Dinan, Stephen Roller, Kurt Shuster, Angela Fan, Michael Auli, and Jason Weston. Wizard of wikipedia: Knowledge-powered conversational agents. *arXiv preprint arXiv:1811.01241*, 2018.
1437. Eric Michael Smith, Mary Williamson, Kurt Shuster, Jason Weston, and Y-Lan Boureau. Can you put it all together: Evaluating conversational agents’ ability to blend skills. *arXiv preprint arXiv:2004.08449*, 2020.
1438. Yida Wang, Pei Ke, Yinhe Zheng, Kaili Huang, Yong Jiang, Xiaoyan Zhu, and Minlie Huang. A large-scale chinese short-text conversation dataset. In *CCF International Conference on Natural Language Processing and Chinese Computing*, pages 91–103. Springer, 2020.
1439. Jiwei Li, Michel Galley, Chris Brockett, Georgios Spithourakis, Jianfeng Gao, and Bill Dolan. A persona-based neural conversation model. In *ACL*, pages 994–1003, 2016.
1440. Yury Zemlyanskiy and Fei Sha. Aiming to know you better perhaps makes me a more engaging dialogue partner. In *Proceedings of the 22nd Conference on Computational Natural Language Learning*, pages 551–561, Brussels, Belgium, October 2018. Association for Computational Linguistics.
1441. Semih Yavuz, Abhinav Rastogi, Guan-Lin Chao, and Dilek Hakkani-Tur. DeepCopy: Grounded response generation with hierarchical pointer networks. In *Proceedings of the 20th Annual SIGdial Meeting on Discourse and Dialogue*, pages 122–132, Stockholm, Sweden, September 2019. Association for Computational Linguistics.
1442. Haoyu Song, Wei-Nan Zhang, Yiming Cui, Dong Wang, and Ting Liu. Exploiting persona information for diverse generation of conversational responses. In *Proceedings of the Twenty-Eighth International Joint Conference on Artificial Intelligence, IJCAI-19*, pages 5190–5196. International Joint Conferences on Artificial Intelligence Organization, 7 2019.
1443. Qian Liu, Yihong Chen, Bei Chen, Jian-Guang Lou, Zixuan Chen, Bin Zhou, and Dongmei Zhang. You impress me: Dialogue generation via mutual persona perception. In *Proceedings of the 58th Annual Meeting of the Association for Computational Linguistics*, pages 1417–1427, Online, July 2020. Association for Computational Linguistics.
1444. Sergey Golovanov, Rauf Kurbanov, Sergey Nikolenko, Kyril Truskovskiy, Alexander Tselousov, and Thomas Wolf. Large-scale transfer learning for natural language generation. In *Proceedings of the 57th Annual Meeting of the Association for Computational Linguistics*, pages 6053–6058, Florence, Italy, July 2019. Association for Computational Linguistics.
1445. Haoyu Song, Yan Wang, Kaiyan Zhang, Wei-Nan Zhang, and Ting Liu. BoB: BERT over BERT for training persona-based dialogue models from limited personalized data. In *Proceedings of the 59th Annual Meeting of the Association for Computational Linguistics and the 11th International Joint Conference on Natural Language Processing (Volume 1: Long Papers)*, pages 167–177, Online, August 2021. Association for Computational Linguistics.
1446. Thomas Wolf, Victor Sanh, Julien Chaumond, and Clement Delangue. Transfertransfo: A transfer learning approach for neural network based conversational agents. *CoRR*, abs/1901.08149, 2019.
1447. Andrea Madotto, Zhaojiang Lin, Chien-Sheng Wu, and Pascale Fung. Personalizing dialogue agents via meta-learning. In *Proceedings of the 57th Annual Meeting of the Association for Computational Linguistics*, pages 5454–5459, Florence, Italy, July 2019. Association for Computational Linguistics.
1448. Ruifang Wang, Ruifang He, Longbiao Wang, Yuke Si, Huanyu Liu, Haocheng Wang, and Jianwu Dang. Exploiting explicit and inferred implicit personas for multi-turn dialogue generation. In Lu Wang, Yansong Feng, Yu Hong, and Ruifang He, editors, *Natural Language Processing and Chinese Computing*, pages 493–504, Cham, 2021. Springer International Publishing.
1449. Haiyan Fan and Marshall Scott Poole. What is personalization? perspectives on the design and implementation of personalization in information systems. *Journal of Organizational Computing and Electronic Commerce*, 16(3-4):179–202, 2006.
1450. Yinhe Zheng, Guanyi Chen, Minlie Huang, Song Liu, and Xuan Zhu. Personalized dialogue generation with diversified traits. *arXiv preprint arXiv:1901.09672*, 2019.
1451. Jeessoo Bang, Hyungjong Noh, Yonghee Kim, and Gary Geunbae Lee. Example-based chat-oriented dialogue system with personalized long-term memory. In *2015 International Conference on Big Data and Smart Computing (BIGCOMP)*, pages 238–243. IEEE, 2015.
1452. Yukun Ma, Khanh Linh Nguyen, Frank Z Xing, and Erik Cambria. A survey on empathetic dialogue systems. *Information Fusion*, 64:50–70, 2020.
1453. Qiao Qian, Minlie Huang, Haizhou Zhao, Jingfang Xu, and Xiaoyan Zhu. Assigning personality/profile to a chatting machine for coherent conversation generation. In *Proceedings of the Twenty-Seventh International Joint Conference on*

- Artificial Intelligence, IJCAI-18*, pages 4279–4285. International Joint Conferences on Artificial Intelligence Organization, 7 2018.
1454. Alessandro Sordoni, Michel Galley, Michael Auli, Chris Brockett, Yangfeng Ji, Margaret Mitchell, Jian-Yun Nie, Jianfeng Gao, and William B Dolan. A neural network approach to context-sensitive generation of conversational responses. In *Proceedings of the 2015 Conference of the North American Chapter of the Association for Computational Linguistics: Human Language Technologies*, pages 196–205, 2015.
1455. Rami Al-Rfou, Marc Pickett, Javier Snaider, Yun-hsuan Sung, Brian Strope, and Ray Kurzweil. Conversational contextual cues: The case of personalization and history for response ranking. *arXiv preprint arXiv:1606.00372*, 2016.
1456. Kaixiang Mo, Yu Zhang, Shuangyin Li, Jiajun Li, and Qiang Yang. Personalizing a dialogue system with transfer reinforcement learning. In *Proceedings of the AAAI Conference on Artificial Intelligence*, volume 32, 2018.
1457. Liangchen Luo, Wenhao Huang, Qi Zeng, Zaiqing Nie, and Xu Sun. Learning personalized end-to-end goal-oriented dialog. In *Proceedings of the AAAI Conference on Artificial Intelligence*, volume 33, pages 6794–6801, 2019.
1458. Oluwatobi O. Olabiyi, Anish Khazane, and Erik T. Mueller. A persona-based multi-turn conversation model in an adversarial learning framework. In *2018 17th IEEE International Conference on Machine Learning and Applications (ICMLA)*, pages 489–494, 2018.
1459. Min Yang, Wenting Tu, Qiang Qu, Zhou Zhao, Xiaojun Chen, and Jia Zhu. Personalized response generation by dual-learning based domain adaptation. *Neural Networks*, 103:72–82, 2018.
1460. William Cai, Josh Grossman, Zhiyuan Jerry Lin, Hao Sheng, Johnny Tian-Zheng Wei, Joseph Jay Williams, and Sharad Goel. Bandit algorithms to personalize educational chatbots. *Machine Learning*, pages 1–30, 2021.
1461. Cynthia A Thompson, Mehmet H Goker, and Pat Langley. A personalized system for conversational recommendations. *Journal of Artificial Intelligence Research*, 21:393–428, 2004.
1462. Ahmet Baki Kocaballi, Shlomo Berkovsky, Juan C Quiroz, Liliana Laranjo, Huong Ly Tong, Dana Rezazadegan, Agustina Briatore, and Enrico Coiera. The personalization of conversational agents in health care: systematic review. *Journal of medical Internet research*, 21(11):e15360, 2019.
1463. Jun Yin, Xin Jiang, Zhengdong Lu, Lifeng Shang, Hang Li, and Xiaoming Li. Neural generative question answering. In *IJCAI'16*, 2016.
1464. Shizhu He, Cao Liu, Kang Liu, and Jun Zhao. Generating natural answers by incorporating copying and retrieving mechanisms in sequence-to-sequence learning. In *Proceedings of the 55th Annual Meeting of the Association for Computational Linguistics (Volume 1: Long Papers)*, pages 199–208, Vancouver, Canada, July 2017. Association for Computational Linguistics.
1465. Tom Young, Erik Cambria, Iti Chaturvedi, Hao Zhou, Subham Biswas, and Minlie Huang. Augmenting end-to-end dialog systems with commonsense knowledge. In *AAAI'18*, 2018.
1466. Marjan Ghazvininejad, Chris Brockett, Ming-Wei Chang, Bill Dolan, Jianfeng Gao, Wen-tau Yih, and Michel Galley. A knowledge-grounded neural conversation model. In *AAAI*, 2018.
1467. Kangyan Zhou, Shrimai Prabhunoye, and Alan W Black. A dataset for document grounded conversations. *arXiv preprint arXiv:1809.07358*, 2018.
1468. Emily Dinan, Varvara Logacheva, Valentin Malykh, Alexander Miller, Kurt Shuster, Jack Urbanek, Douwe Kiela, Arthur Szlam, Iulian Serban, Ryan Lowe, et al. The second conversational intelligence challenge (convai2). *arXiv preprint arXiv:1902.00098*, 2019.
1469. Yizhe Zhang, Michel Galley, Jianfeng Gao, Zhe Gan, Xiujuan Li, Chris Brockett, and Bill Dolan. Generating informative and diverse conversational responses via adversarial information maximization. *arXiv preprint arXiv:1809.05972*, 2018.
1470. Byeongchang Kim, Jaewoo Ahn, and Gunhee Kim. Sequential latent knowledge selection for knowledge-grounded dialogue. *arXiv preprint arXiv:2002.07510*, 2020.
1471. Chuan Meng, Pengjie Ren, Zhumin Chen, Weiwei Sun, Zhaochun Ren, Zhaopeng Tu, and Maarten de Rijke. Dukenet: A dual knowledge interaction network for knowledge-grounded conversation. In *Proceedings of the 43rd International ACM SIGIR Conference on Research and Development in Information Retrieval*, pages 1151–1160, 2020.
1472. Rongzhong Lian, Min Xie, Fan Wang, Jinhua Peng, and Hua Wu. Learning to select knowledge for response generation in dialog systems. *arXiv preprint arXiv:1902.04911*, 2019.
1473. Xiexiong Lin, Weiyu Jian, Jianshan He, Taifeng Wang, and Wei Chu. Generating informative conversational response using recurrent knowledge-interaction and knowledge-copy. In *Proceedings of the 58th Annual Meeting of the Association for Computational Linguistics*, pages 41–52, 2020.
1474. Haolan Zhan, Lei Shen, Hongshen Chen, and Hainan Zhang. Colv: A collaborative latent variable model for knowledge-grounded dialogue generation. In *Proceedings of the 2021 Conference on Empirical Methods in Natural Language Processing*, pages 2250–2261, 2021.
1475. Xueliang Zhao, Wei Wu, Can Xu, Chongyang Tao, Dongyan Zhao, and Rui Yan. Knowledge-grounded dialogue generation with pre-trained language models. In *Proceedings of the 2020 Conference on Empirical Methods in Natural Language Processing (EMNLP)*, pages 3377–3390, 2020.
1476. Sevgi Coşkun Keskin. From what isn't Empathy to Empathic Learning Process. *Procedia - Social and Behavioral Sciences*, 116:4932–4938, 2014.
1477. Babette Rothschild. *Help for the helper: The psychophysiology of compassion fatigue and vicarious trauma*. WW Norton & Company, 2006.
1478. Li Zhou, Jianfeng Gao, Di Li, and Heung-Yeung Shum. The design and implementation of xiaoice, an empathetic social chatbot. *arXiv preprint arXiv:1812.08989*, 2018.

1479. Siyang Liu, Chujie Zheng, Orianna Demasi, Sahand Sabour, Yu Li, Zhou Yu, Yong Jiang, and Minlie Huang. Towards emotional support dialog systems. *arXiv preprint arXiv:2106.01144*, 2021.
1480. Zhaojiang Lin, Andrea Madotto, Jamin Shin, Peng Xu, and Pascale Fung. Moel: Mixture of empathetic listeners. In *Proceedings of the 2019 Conference on Empirical Methods in Natural Language Processing and the 9th International Joint Conference on Natural Language Processing (EMNLP-IJCNLP)*, pages 121–132, 2019.
1481. Ana Paiva, Iolanda Leite, Hana Boukricha, and Ipke Wachsmuth. Empathy in virtual agents and robots: a survey. *ACM Transactions on Interactive Intelligent Systems (TiiS)*, 7(3):1–40, 2017.
1482. Mark H Davis et al. A multidimensional approach to individual differences in empathy. *Journal of Personality and Social Psychology*, 1980.
1483. Becky Lynn Omdahl. *Cognitive appraisal, emotion, and empathy*. Psychology Press, 2014.
1484. Robert Elliott, Arthur C Bohart, Jeanne C Watson, and David Murphy. Therapist empathy and client outcome: An updated meta-analysis. *Psychotherapy*, 55(4):399, 2018.
1485. Ashish Sharma, Adam S Miner, David C Atkins, and Tim Althoff. A computational approach to understanding empathy expressed in text-based mental health support. *arXiv preprint arXiv:2009.08441*, 2020.
1486. Chujie Zheng, Yong Liu, Wei Chen, Yongcai Leng, and Minlie Huang. Comae: A multi-factor hierarchical framework for empathetic response generation. *arXiv preprint arXiv:2105.08316*, 2021.
1487. Sahand Sabour, Chujie Zheng, and Minlie Huang. Cem: Commonsense-aware empathetic response generation. *arXiv preprint arXiv:2109.05739*, 2021.
1488. Brant R Burleson. Emotional support skill. *HANDBOOK OF COMMUNICATION AND SOCIAL INTERACTION SKILLS*, page 551, 2003.
1489. Catherine Penny Hinson Langford, Juanita Bowsher, Joseph P Maloney, and Patricia P Lillis. Social support: a conceptual analysis. *Journal of advanced nursing*, 25(1):95–100, 1997.
1490. Catherine A Heaney and Barbara A Israel. Social networks and social support. *Health behavior and health education: Theory, research, and practice*, 4:189–210, 2008.
1491. JM Van der Zwaan, V Dignum, and CM Jonker. A bdi dialogue agent for social support: Specification and evaluation method. In *AAMAS 2012: Proceedings of the 11th International Conference on Autonomous Agents and Multiagent Systems, Workshop on Emotional and Empathic Agents, Valencia, Spain, 4-8 June 2012; authors version*. International Foundation for Autonomous Agents and Multiagent Systems (IFAAMAS), 2012.
1492. Clara E Hill. *Helping skills: Facilitating, exploration, insight, and action*. American Psychological Association, 2009.
1493. Yu Li, Kun Qian, Weiyan Shi, and Zhou Yu. End-to-end trainable non-collaborative dialog system. In *Proceedings of the AAAI Conference on Artificial Intelligence*, volume 34, pages 8293–8302, 2020.
1494. Marty J Wolf, Keith W Miller, and Frances S Grodzinsky. Why we should have seen that coming: comments on microsoft’s tay “experiment,” and wider implications. *The ORBIT Journal*, 1(2):1–12, 2017.
1495. Heung-Yeung Shum, Xiaodong He, and Di Li. From eliza to xiaoice: Challenges and opportunities with social chatbots. *Frontiers of IT & EE*, 19(1):10–26, 2018.
1496. Emily Dinan, Gavin Abercrombie, A Stevie Bergman, Shannon Spruit, Dirk Hovy, Y-Lan Boureau, and Verena Rieser. Anticipating safety issues in e2e conversational ai: Framework and tooling. *arXiv preprint arXiv:2107.03451*, 2021.
1497. Hao Sun, Guangxuan Xu, Jiawen Deng, Jiale Cheng, Chujie Zheng, Hao Zhou, Nanyun Peng, Xiaoyan Zhu, and Minlie Huang. On the safety of conversational models: Taxonomy, dataset, and benchmark. *arXiv preprint arXiv:2110.08466*, 2021.
1498. Anna Schmidt and Michael Wiegand. A survey on hate speech detection using natural language processing. In *Proceedings of the fifth international workshop on natural language processing for social media*, pages 1–10, 2017.
1499. Paula Fortuna and Sérgio Nunes. A survey on automatic detection of hate speech in text. *ACM Computing Surveys (CSUR)*, 51(4):1–30, 2018.
1500. Md Saroar Jahan and Mourad Oussalah. A systematic review of hate speech automatic detection using natural language processing. *arXiv preprint arXiv:2106.00742*, 2021.
1501. Emily Dinan, Samuel Humeau, Bharath Chintagunta, and Jason Weston. Build it break it fix it for dialogue safety: Robustness from adversarial human attack. *arXiv preprint arXiv:1908.06083*, 2019.
1502. Jing Xu, Da Ju, Margaret Li, Y-Lan Boureau, Jason Weston, and Emily Dinan. Recipes for safety in open-domain chatbots. *arXiv preprint arXiv:2010.07079*, 2020.
1503. Emily Sheng, Kai-Wei Chang, Prem Natarajan, and Nanyun Peng. “nice try, kiddo”: Investigating ad hominem in dialogue responses. In *Proceedings of the 2021 Conference of the North American Chapter of the Association for Computational Linguistics: Human Language Technologies*, pages 750–767, 2021.
1504. Alaa Ali Abd-Alrazaq, Asma Rababeh, Mohannad Alajlani, Bridgette M Bewick, and Mowafa Househ. Effectiveness and safety of using chatbots to improve mental health: systematic review and meta-analysis. *Journal of medical Internet research*, 22(7):e16021, 2020.
1505. Hao Sun, Zhenru Lin, Chujie Zheng, Siyang Liu, and Minlie Huang. Psyqa: A chinese dataset for generating long counseling text for mental health support. *arXiv preprint arXiv:2106.01702*, 2021.
1506. Amit Mittal, Ayushi Agrawal, Ayushi Chouksey, Rachna Shriwas, and Saloni Agrawal. A comparative study of chatbots and humans. *Situations*, 2(2), 2016.
1507. Timothy W Bickmore, Ha Trinh, Stefan Olafsson, Teresa K O’Leary, Reza Asadi, Nathaniel M Rickles, and Ricardo Cruz. Patient and consumer safety risks when using conversational assistants for medical information: an observational study of siri, alexa, and google assistant. *Journal of medical Internet research*, 20(9):e11510, 2018.

1508. Antonella De Angeli, Rollo Carpenter, et al. Stupid computer! abuse and social identities. In *Proc. INTERACT 2005 workshop Abuse: The darker side of Human-Computer Interaction*, pages 19–25. Citeseer, 2005.
1509. Antonella De Angeli and Sheryl Brahnam. I hate you! disinhibition with virtual partners. *Interacting with computers*, 20(3):302–310, 2008.
1510. Su Lin Blodgett, Solon Barocas, Hal Daumé III, and Hanna Wallach. Language (technology) is power: A critical survey of "bias" in nlp. *arXiv preprint arXiv:2005.14050*, 2020.
1511. Ashutosh Baheti, Maarten Sap, Alan Ritter, and Mark Riedl. Just say no: Analyzing the stance of neural dialogue generation in offensive contexts. *arXiv preprint arXiv:2108.11830*, 2021.
1512. Amanda Cercas Curry and Verena Rieser. #metoo alexa: How conversational systems respond to sexual harassment. In *Proceedings of the second acl workshop on ethics in natural language processing*, pages 7–14, 2018.
1513. Yejin Bang, Nayeon Lee, Etsuko Ishii, Andrea Madotto, and Pascale Fung. Assessing political prudence of open-domain chatbots. *arXiv preprint arXiv:2106.06157*, 2021.
1514. Nikita Nangia, Clara Vania, Rasika Bhalerao, and Samuel R Bowman. Crows-pairs: A challenge dataset for measuring social biases in masked language models. *arXiv preprint arXiv:2010.00133*, 2020.
1515. Patrick Schramowski, Cigdem Turan, Nico Andersen, Constantin Rothkopf, and Kristian Kersting. Language models have a moral dimension. *arXiv preprint arXiv:2103.11790*, 2021.
1516. Laura Hanu and Unitary team. Detoxify. Github. <https://github.com/unitaryai/detoxify>, 2020.
1517. Kevin Yang and Dan Klein. Fudge: Controlled text generation with future discriminators. *arXiv preprint arXiv:2104.05218*, 2021.
1518. Ben Krause, Akhilesh Deepak Gotmare, Bryan McCann, Nitish Shirish Keskar, Shafiq Joty, Richard Socher, and Nazneen Fatema Rajani. Gedi: Generative discriminator guided sequence generation. *arXiv preprint arXiv:2009.06367*, 2020.
1519. Alisa Liu, Maarten Sap, Ximing Lu, Swabha Swayamdipta, Chandra Bhagavatula, Noah A Smith, and Yejin Choi. Dexperts: Decoding-time controlled text generation with experts and anti-experts. In *Proceedings of the 59th Annual Meeting of the Association for Computational Linguistics and the 11th International Joint Conference on Natural Language Processing (Volume 1: Long Papers)*, pages 6691–6706, 2021.
1520. Timo Schick, Sahana Udupa, and Hinrich Schütze. Self-diagnosis and self-debiasing: A proposal for reducing corpus-based bias in nlp. *arXiv preprint arXiv:2103.00453*, 2021.
1521. Emily Sheng, Kai-Wei Chang, Premkumar Natarajan, and Nanyun Peng. Towards controllable biases in language generation. *arXiv preprint arXiv:2005.00268*, 2020.
1522. Liwei Jiang, Jena D Hwang, Chandra Bhagavatula, Ronan Le Bras, Maxwell Forbes, Jon Borchardt, Jenny Liang, Oren Etzioni, Maarten Sap, and Yejin Choi. Delphi: Towards machine ethics and norms. *arXiv preprint arXiv:2110.07574*, 2021.
1523. Malik Ghallab. Responsible ai: requirements and challenges. *AI Perspectives*, 1(1):1–7, 2019.
1524. Dorian Peters, Karina Vold, Diana Robinson, and Rafael A Calvo. Responsible ai—two frameworks for ethical design practice. *IEEE Transactions on Technology and Society*, 1(1):34–47, 2020.
1525. John Jumper, Richard Evans, Alexander Pritzel, Tim Green, Michael Figurnov, Olaf Ronneberger, Kathryn Tunyasuvunakool, Russ Bates, Augustin Žídek, Anna Potapenko, et al. Highly accurate protein structure prediction with alphafold. *Nature*, 596(7873):583–589, 2021.
1526. J Wang, S Lisanza, D Juergens, D Tischer, I Anishchenko, M Baek, JL Watson, J Chun, LF Milles, J Dauparas, et al. Deep learning methods for designing proteins scaffolding functional sites. 2021.
1527. Kevin K Yang, Zachary Wu, and Frances H Arnold. Machine-learning-guided directed evolution for protein engineering. *Nature methods*, 16(8):687–694, 2019.
1528. Ethan C Alley, Grigory Khimulya, Surojit Biswas, Mohammed AlQuraishi, and George M Church. Unified rational protein engineering with sequence-based deep representation learning. *Nature methods*, 16(12):1315–1322, 2019.
1529. Roshan Rao, Nicholas Bhattacharya, Neil Thomas, Yan Duan, Xi Chen, John Canny, Pieter Abbeel, and Yun S Song. Evaluating protein transfer learning with tape. *Advances in neural information processing systems*, 32:9689, 2019.
1530. Alexander Rives, Joshua Meier, Tom Sercu, Siddharth Goyal, Zeming Lin, Jason Liu, Demi Guo, Myle Ott, C Lawrence Zitnick, Jerry Ma, et al. Biological structure and function emerge from scaling unsupervised learning to 250 million protein sequences. *Proceedings of the National Academy of Sciences*, 118(15), 2021.
1531. Ahmed Elnaggar, Michael Heinzinger, Christian Dallago, Ghaliya Rihawi, Yu Wang, Llion Jones, Tom Gibbs, Tamas Feher, Christoph Angerer, Martin Steinegger, et al. Prottrans: towards cracking the language of life’s code through self-supervised deep learning and high performance computing. *arXiv preprint arXiv:2007.06225*, 2020.
1532. Amy X Lu, Haoran Zhang, Marzyeh Ghassemi, and Alan M Moses. Self-supervised contrastive learning of protein representations by mutual information maximization. *BioRxiv*, 2020.
1533. Liang He, Shizhuo Zhang, Lijun Wu, Huanhuan Xia, Fusong Ju, He Zhang, Siyuan Liu, Yingce Xia, Jianwei Zhu, Pan Deng, et al. Pre-training co-evolutionary protein representation via a pairwise masked language model. *arXiv preprint arXiv:2110.15527*, 2021.
1534. Tristan Bepler and Bonnie Berger. Learning protein sequence embeddings using information from structure. *arXiv preprint arXiv:1902.08661*, 2019.
1535. Tristan Bepler and Bonnie Berger. Learning the protein language: Evolution, structure, and function. *Cell Systems*, 12(6):654–669, 2021.



1536. Roshan Rao, Jason Liu, Robert Verkuil, Joshua Meier, John F Canny, Pieter Abbeel, Tom Sercu, and Alexander Rives. Msa transformer. *bioRxiv*, 2021.
1537. Surojit Biswas, Grigory Khimulya, Ethan C Alley, Kevin M Esvelt, and George M Church. Low-n protein engineering with data-efficient deep learning. *Nature Methods*, 18(4):389–396, 2021.
1538. Fiona Cunningham, Premanand Achuthan, Wasiu Akanni, James Allen, M Ridwan Amode, Irina M Armean, Ruth Bennett, Jyothish Bhai, Konstantinos Billis, Sanjay Boddu, et al. Ensembl 2019. *Nucleic acids research*, 47(D1):D745–D751, 2019.
1539. Roshan Rao, Joshua Meier, Tom Sercu, Sergey Ovchinnikov, and Alexander Rives. Transformer protein language models are unsupervised structure learners. In *International Conference on Learning Representations*, 2020.
1540. Jesse Vig, Ali Madani, Lav R Varshney, Caiming Xiong, Richard Socher, and Nazneen Fatema Rajani. Bertology meets biology: Interpreting attention in protein language models. *arXiv preprint arXiv:2006.15222*, 2020.
1541. Yanbin Wang, Zhu-Hong You, Shan Yang, Xiao Li, Tong-Hai Jiang, and Xi Zhou. A high efficient biological language model for predicting protein–protein interactions. *Cells*, 8(2):122, 2019.
1542. Hao Zhang, Renchu Guan, Fengfeng Zhou, Yanchun Liang, Zhi-Hui Zhan, Lan Huang, and Xiaoyue Feng. Deep residual convolutional neural network for protein-protein interaction extraction. *IEEE Access*, 7:89354–89365, 2019.
1543. Ben Krause, Liang Lu, Iain Murray, and Steve Renals. Multiplicative lstm for sequence modelling. *arXiv preprint arXiv:1609.07959*, 2016.
1544. Baris E Suzek, Hongzhan Huang, Peter McGarvey, Raja Mazumder, and Cathy H Wu. Uniref: comprehensive and non-redundant uniprot reference clusters. *Bioinformatics*, 23(10):1282–1288, 2007.
1545. Sara El-Gebali, Jaina Mistry, Alex Bateman, Sean R Eddy, Aurélien Luciani, Simon C Potter, Matloob Qureshi, Lorna J Richardson, Gustavo A Salazar, Alfredo Smart, et al. The pfam protein families database in 2019. *Nucleic acids research*, 47(D1):D427–D432, 2019.
1546. Martin Steinegger and Johannes Söding. Clustering huge protein sequence sets in linear time. *Nature communications*, 9(1):1–8, 2018.
1547. Charles Yanofsky, Virginia Horn, and Deanna Thorpe. Protein structure relationships revealed by mutational analysis. *Science*, 146(3651):1593–1594, 1964.
1548. D Altschuh, T Vernet, P Berti, D Moras, and K Nagai. Coordinated amino acid changes in homologous protein families. *Protein Engineering, Design and Selection*, 2(3):193–199, 1988.
1549. Ulrike Göbel, Chris Sander, Reinhard Schneider, and Alfonso Valencia. Correlated mutations and residue contacts in proteins. *Proteins: Structure, Function, and Bioinformatics*, 18(4):309–317, 1994.
1550. Jonathan Ho, Nal Kalchbrenner, Dirk Weissenborn, and Tim Salimans. Axial attention in multidimensional transformers. *arXiv preprint arXiv:1912.12180*, 2019.
1551. Freyr Sverrisson, Jean Feydy, Bruno E Correia, and Michael M Bronstein. Fast end-to-end learning on protein surfaces. In *Proceedings of the IEEE/CVF Conference on Computer Vision and Pattern Recognition*, pages 15272–15281, 2021.
1552. P Gainza, F Sverrisson, F Monti, E Rodolà, D Boscaini, MM Bronstein, and BE Correia. Deciphering interaction fingerprints from protein molecular surfaces using geometric deep learning. *Nature Methods*, 17(2):184–192, 2020.
1553. Pedro Hermosilla, Marco Schäfer, Matěj Lang, Gloria Fackelmann, Pere Pau Vázquez, Barbora Kozlíková, Michael Krone, Tobias Ritschel, and Timo Ropinski. Intrinsic-extrinsic convolution and pooling for learning on 3d protein structures. *International Conference on Learning Representations*, 2021.
1554. Brian Kuhlman and Philip Bradley. Advances in protein structure prediction and design. *Nature Reviews Molecular Cell Biology*, 20(11):681–697, 2019.
1555. Ambrish Roy, Alper Kucukural, and Yang Zhang. I-tasser: a unified platform for automated protein structure and function prediction. *Nature protocols*, 5(4):725–738, 2010.
1556. Vladimir Gligorijević, P Douglas Renfrew, Tomasz Kosciolk, Julia Koehler Leman, Daniel Berenberg, Tommi Vatanen, Chris Chandler, Bryn C Taylor, Ian M Fisk, Hera Vlamakis, et al. Structure-based protein function prediction using graph convolutional networks. *Nature communications*, 12(1):1–14, 2021.
1557. Minkyung Baek, Frank DiMaio, Ivan Anishchenko, Justas Dauparas, Sergey Ovchinnikov, Gyu Rie Lee, Jue Wang, Qian Cong, Lisa N Kinch, R Dustin Schaeffer, et al. Accurate prediction of protein structures and interactions using a three-track neural network. *Science*, 373(6557):871–876, 2021.
1558. Christophe N Magnan and Pierre Baldi. Sspro/accpro 5: almost perfect prediction of protein secondary structure and relative solvent accessibility using profiles, machine learning and structural similarity. *Bioinformatics*, 30(18):2592–2597, 2014.
1559. Ian Walsh, Davide Baù, Alberto JM Martin, Catherine Mooney, Alessandro Vullo, and Gianluca Pollastri. Ab initio and template-based prediction of multi-class distance maps by two-dimensional recursive neural networks. *BMC structural biology*, 9(1):1–20, 2009.
1560. Catherine Mooney and Gianluca Pollastri. Beyond the twilight zone: automated prediction of structural properties of proteins by recursive neural networks and remote homology information. *Proteins: Structure, Function, and Bioinformatics*, 77(1):181–190, 2009.
1561. Gianluca Pollastri, Alberto JM Martin, Catherine Mooney, and Alessandro Vullo. Accurate prediction of protein secondary structure and solvent accessibility by consensus combiners of sequence and structure information. *BMC bioinformatics*, 8(1):1–12, 2007.
1562. Stephen F Altschul, Thomas L Madden, Alejandro A Schäfer, Jinghui Zhang, Zheng Zhang, Webb Miller, and David J Lipman. Gapped blast and psi-blast: a new generation of protein database search programs. *Nucleic acids research*, 25(17):3389–3402, 1997.

1563. Andrew Waterhouse, Martino Bertoni, Stefan Bienert, Gabriel Studer, Gerardo Tauriello, Rafal Gumienny, Florian T Heer, Tjaart A P de Beer, Christine Rempfer, Lorenza Bordoli, et al. Swiss-model: homology modelling of protein structures and complexes. *Nucleic acids research*, 46(W1):W296–W303, 2018.
1564. Narayanan Eswar, David Eramian, Ben Webb, Min-Yi Shen, and Andrej Sali. Protein structure modeling with modeller. In *Structural proteomics*, pages 145–159. Springer, 2008.
1565. Sheng Wang, Siqi Sun, Zhen Li, Renyu Zhang, and Jinbo Xu. Accurate de novo prediction of protein contact map by ultra-deep learning model. *PLoS computational biology*, 13(1):e1005324, 2017.
1566. Jian Zhou and Olga Troyanskaya. Deep supervised and convolutional generative stochastic network for protein secondary structure prediction. In *International conference on machine learning*, pages 745–753. PMLR, 2014.
1567. Andrew W Senior, Richard Evans, John Jumper, James Kirkpatrick, Laurent Sifre, Tim Green, Chongli Qin, Augustin Židek, Alexander WR Nelson, Alex Bridgland, et al. Improved protein structure prediction using potentials from deep learning. *Nature*, 577(7792):706–710, 2020.
1568. Jianyi Yang, Ivan Anishchenko, Hahnbeom Park, Zhenling Peng, Sergey Ovchinnikov, and David Baker. Improved protein structure prediction using predicted interresidue orientations. *Proceedings of the National Academy of Sciences*, 117(3):1496–1503, 2020.
1569. Mohammed AlQurashi. End-to-end differentiable learning of protein structure. *Cell systems*, 8(4):292–301, 2019.
1570. Jinbo Xu. Distance-based protein folding powered by deep learning. *Proceedings of the National Academy of Sciences*, 116(34):16856–16865, 2019.
1571. John Ingraham, Adam Riesselman, Chris Sander, and Debora Marks. Learning protein structure with a differentiable simulator. In *International Conference on Learning Representations*, 2018.
1572. Sergey Ovchinnikov, Milot Mirdita, and Martin Steinegger. Colabfold-making protein folding accessible to all via google colab, 2021.
1573. Junsu Ko and Juyong Lee. Can alphafold2 predict protein-peptide complex structures accurately? *bioRxiv*, 2021.
1574. Tomer Tsaban, Julia Varga, Orly Avraham, Ziv Ben-Aharon, Alisa Khramushin, and Ora Schueler-Furman. Harnessing protein folding neural networks for peptide-protein docking. 2021.
1575. Patrick Bryant, Gabriele Pozzati, and Arne Elofsson. Improved prediction of protein-protein interactions using alphafold2 and extended multiple-sequence alignments. *bioRxiv*, 2021.
1576. Richard Evans, Michael O’Neill, Alexander Pritzel, Natasha Antropova, Andrew W Senior, Timothy Green, Augustin Židek, Russell Bates, Sam Blackwell, Jason Yim, et al. Protein complex prediction with alphafold-multimer. *bioRxiv*, 2021.
1577. Ian R Humphreys, Jimin Pei, Minkyung Baek, Aditya Krishnakumar, Ivan Anishchenko, Sergey Ovchinnikov, Jing Zhang, Travis J Ness, Sudeep Banjade, Saket R Bagde, et al. Computed structures of core eukaryotic protein complexes. *Science*, page eabm4805, 2021.
1578. Shoshana J Wodak, James Vlasblom, Andrei L Turinsky, and Shuye Pu. Protein-protein interaction networks: the puzzling riches. *Current opinion in structural biology*, 23(6):941–953, 2013.
1579. Long Lu, Hui Lu, and Jeffrey Skolnick. Multiprospector: an algorithm for the prediction of protein-protein interactions by multimeric threading. *Proteins: Structure, Function, and Bioinformatics*, 49(3):350–364, 2002.
1580. Srayanta Mukherjee and Yang Zhang. Protein-protein complex structure predictions by multimeric threading and template recombination. *Structure*, 19(7):955–966, 2011.
1581. Andras Szilagy and Yang Zhang. Template-based structure modeling of protein-protein interactions. *Current opinion in structural biology*, 24:10–23, 2014.
1582. Utkan Ogmen, Ozlem Keskin, A Selim Aytuna, Ruth Nussinov, and Attila Gursoy. Prism: protein interactions by structural matching. *Nucleic acids research*, 33(suppl\_2):W331–W336, 2005.
1583. Nurcan Tuncbag, Attila Gursoy, Ruth Nussinov, and Ozlem Keskin. Predicting protein-protein interactions on a proteome scale by matching evolutionary and structural similarities at interfaces using prism. *Nature protocols*, 6(9):1341–1354, 2011.
1584. Rohita Sinha, Petras J Kundrotas, and Ilya A Vakser. Docking by structural similarity at protein-protein interfaces. *Proteins: Structure, Function, and Bioinformatics*, 78(15):3235–3241, 2010.
1585. Thom Vreven, Howook Hwang, Brian G Pierce, and Zhiping Weng. Evaluating template-based and template-free protein-protein complex structure prediction. *Briefings in bioinformatics*, 15(2):169–176, 2014.
1586. Graham R Smith and Michael JE Sternberg. Prediction of protein-protein interactions by docking methods. *Current opinion in structural biology*, 12(1):28–35, 2002.
1587. David W Ritchie. Recent progress and future directions in protein-protein docking. *Current protein and peptide science*, 9(1):1–15, 2008.
1588. Iain H Moal, Mieczyslaw Torchala, Paul A Bates, and Juan Fernández-Recio. The scoring of poses in protein-protein docking: current capabilities and future directions. *BMC bioinformatics*, 14(1):1–15, 2013.
1589. Sankar Basu and Björn Wallner. Dockq: a quality measure for protein-protein docking models. *PloS one*, 11(8):e0161879, 2016.
1590. Guillaume Launay, Masahito Ohue, Julia Prieto Santero, Yuri Matsuzaki, Cécile Hilpert, Nobuyuki Uchikoga, Takanori Hayashi, and Juliette Martin. Evaluation of consrank-like scoring functions for rescoring ensembles of protein-protein docking poses. *Frontiers in molecular biosciences*, 7:308, 2020.
1591. Stephan Eismann, Raphael JL Townshend, Nathaniel Thomas, Milind Jagota, Bowen Jing, and Ron O Dror. Hierarchical, rotation-equivariant neural networks to select structural models of protein complexes. *Proteins: Structure, Function, and Bioinformatics*, 89(5):493–501, 2021.

1592. Jacob Verburgt and Daisuke Kihara. Benchmarking of structure refinement methods for protein complex models. *Proteins: Structure, Function, and Bioinformatics*, 2021.
1593. Minkyung Baek, Ivan Anishchenko, Hahnbeom Park, Ian R Humphreys, and David Baker. Protein oligomer modeling guided by predicted interchain contacts in casp14. *Proteins: Structure, Function, and Bioinformatics*, 2021.
1594. Justas Dapkunas, Kliment Olechnovič, and Česlovas Venclovas. Modeling of protein complexes in casp14 with emphasis on the interaction interface prediction. *Authorea Preprints*, 2021.
1595. Usman Ghani, Israel Desta, Akhil Jindal, Omeir Khan, George Jones, Sergey Kotelnikov, Dzmityr Padhorny, Sandor Vajda, and Dima Kozakov. Improved docking of protein models by a combination of alphafold2 and cluspro. *bioRxiv*, 2021.
1596. Dima Kozakov, David R Hall, Bing Xia, Kathryn A Porter, Dzmityr Padhorny, Christine Yueh, Dmitri Beglov, and Sandor Vajda. The cluspro web server for protein–protein docking. *Nature protocols*, 12(2):255–278, 2017.
1597. Jimin Pei, Jing Zhang, and Qian Cong. Human mitochondrial protein complexes revealed by large-scale coevolution analysis and deep learning-based structure modeling. *bioRxiv*, 2021.
1598. Qian Cong, Ivan Anishchenko, Sergey Ovchinnikov, and David Baker. Protein interaction networks revealed by proteome coevolution. *Science*, 365(6449):185–189, 2019.
1599. Anna G Green, Hadeer Elhabashy, Kelly P Brock, Rohan Maddamsetti, Oliver Kohlbacher, and Debora S Marks. Proteome-scale discovery of protein interactions with residue-level resolution using sequence coevolution. *bioRxiv*, page 791293, 2019.
1600. Hong Zeng, Sheng Wang, Tianming Zhou, Feifeng Zhao, Xiufeng Li, Qing Wu, and Jinbo Xu. Complexcontact: a web server for inter-protein contact prediction using deep learning. *Nucleic acids research*, 46(W1):W432–W437, 2018.
1601. Tian Ming Zhou, Sheng Wang, and Jinbo Xu. Deep learning reveals many more inter-protein residue-residue contacts than direct coupling analysis. In *22nd International Conference on Research in Computational Molecular Biology, RECOMB 2018*, pages 295–296. Springer-Verlag, 2018.
1602. Xingjie Pan and Tanja Kortemme. Recent advances in de novo protein design: Principles, methods, and applications. *Journal of Biological Chemistry*, page 100558, 2021.
1603. Alex T Muller, Jan A Hiss, and Gisbert Schneider. Recurrent neural network model for constructive peptide design. *Journal of chemical information and modeling*, 58(2):472–479, 2018.
1604. Adam Riesselman, Jung-Eun Shin, Aaron Kollasch, Conor McMahon, Elana Simon, Chris Sander, Aashish Manglik, Andrew Kruse, and Debora Marks. Accelerating protein design using autoregressive generative models. *BioRxiv*, page 757252, 2019.
1605. Ali Madani, Bryan McCann, Nikhil Naik, Nitish Shirish Keskar, Namrata Anand, Raphael R Eguchi, Po-Ssu Huang, and Richard Socher. Progen: Language modeling for protein generation. *arXiv preprint arXiv:2004.03497*, 2020.
1606. Nathan Killoran, Leo J Lee, Andrew Delong, David Duvenaud, and Brendan J Frey. Generating and designing dna with deep generative models. *arXiv preprint arXiv:1712.06148*, 2017.
1607. Payel Das, Kahini Wadhawan, Oscar Chang, Tom Sercu, Cicero Dos Santos, Matthew Riemer, Vijil Chenthamarakshan, Inkit Padhi, and Aleksandra Mojsilovic. Pepcvae: Semi-supervised targeted design of antimicrobial peptide sequences. *arXiv preprint arXiv:1810.07743*, 2018.
1608. Anvita Gupta and James Zou. Feedback gan (fbgan) for dna: A novel feedback-loop architecture for optimizing protein functions. *arXiv preprint arXiv:1804.01694*, 2018.
1609. Wenhao Gao, Sai Pooja Mahajan, Jeremias Sulam, and Jeffrey J Gray. Deep learning in protein structural modeling and design. *Patterns*, page 100142, 2020.
1610. Brian Kuhlman, Gautam Dantas, Gregory C Ireton, Gabriele Varani, Barry L Stoddard, and David Baker. Design of a novel globular protein fold with atomic-level accuracy. *science*, 302(5649):1364–1368, 2003.
1611. Craig O Mackenzie and Gevorg Grigoryan. Protein structural motifs in prediction and design. *Current opinion in structural biology*, 44:161–167, 2017.
1612. Rosalie Lipsh-Sokolik, Dina Listov, and Sarel J Fleishman. The abdesign computational pipeline for modular backbone assembly and design of binders and enzymes. *Protein Science*, 30(1):151–159, 2021.
1613. Brian Koepnick, Jeff Flatten, Tamir Husain, Alex Ford, Daniel-Adriano Silva, Matthew J Bick, Aaron Bauer, Gaohua Liu, Yojiro Ishida, Alexander Boykov, et al. De novo protein design by citizen scientists. *Nature*, 570(7761):390–394, 2019.
1614. Seth Cooper, Firas Khatib, Adrien Treuille, Janos Barbero, Jeehyung Lee, Michael Beenen, Andrew Leaver-Fay, David Baker, Zoran Popović, et al. Predicting protein structures with a multiplayer online game. *Nature*, 466(7307):756–760, 2010.
1615. Che Yang, Fabian Sesterhenn, Jaume Bonet, Eva A van Aalen, Leo Scheller, Luciano A Abriata, Johannes T Cramer, Xiaolin Wen, Stéphane Rosset, Sandrine Georgeon, et al. Bottom-up de novo design of functional proteins with complex structural features. *Nature Chemical Biology*, 17(4):492–500, 2021.
1616. Daniela Röthlisberger, Olga Khersonsky, Andrew M Wollacott, Lin Jiang, Jason DeChancie, Jamie Betker, Jasmine L Gallaher, Eric A Althoff, Alexandre Zanghellini, Orly Dym, et al. Kemp elimination catalysts by computational enzyme design. *Nature*, 453(7192):190–195, 2008.
1617. Christine E Tinberg, Sagar D Khare, Jiayi Dou, Lindsey Doyle, Jorgen W Nelson, Alberto Schena, Wojciech Jankowski, Charalampos G Kalodimos, Kai Johnsson, Barry L Stoddard, et al. Computational design of ligand-binding proteins with high affinity and selectivity. *Nature*, 501(7466):212–216, 2013.

1618. Daniel A Keedy, Ivelin Georgiev, Edward B Triplett, Bruce R Donald, David C Richardson, and Jane S Richardson. The role of local backrub motions in evolved and designed mutations. 2012.
1619. Namrata Anand and Possu Huang. Generative modeling for protein structures. 2018.
1620. Namrata Anand, Raphael Eguchi, and Po-Ssu Huang. Fully differentiable full-atom protein backbone generation. 2019.
1621. Raphael R Eguchi, Namrata Anand, Christian Andrew Choe, and Po-Ssu Huang. Ig-vae: generative modeling of immunoglobulin proteins by direct 3d coordinate generation. *bioRxiv*, 2020.
1622. Ivan Anishchenko, Tamuka Martin Chidyausiku, Sergey Ovchinnikov, Samuel J Pellock, and David Baker. De novo protein design by deep network hallucination. *bioRxiv*, 2020.
1623. Rebecca F Alford, Andrew Leaver-Fay, Jeliazko R Jeliazkov, Matthew J O’Meara, Frank P DiMaio, Hahnbeom Park, Maxim V Shapovalov, P Douglas Renfrew, Vikram K Mulligan, Kalli Kappel, et al. The rosetta all-atom energy function for macromolecular modeling and design. *Journal of chemical theory and computation*, 13(6):3031–3048, 2017.
1624. Matthew J O’Meara, Andrew Leaver-Fay, Michael D Tyka, Amelie Stein, Kevin Houlihan, Frank DiMaio, Philip Bradley, Tanja Kortemme, David Baker, Jack Snoeyink, et al. Combined covalent-electrostatic model of hydrogen bonding improves structure prediction with rosetta. *Journal of chemical theory and computation*, 11(2):609–622, 2015.
1625. F Edward Boas and Pehr B Harbury. Potential energy functions for protein design. *Current opinion in structural biology*, 17(2):199–204, 2007.
1626. Christopher Lee and S Subbiah. Prediction of protein side-chain conformation by packing optimization. *Journal of molecular biology*, 217(2):373–388, 1991.
1627. Enrique Marcos, Benjamin Basanta, Tamuka M Chidyausiku, Yuefeng Tang, Gustav Oberdorfer, Gaohua Liu, GVT Swapna, Rongjin Guan, Daniel-Adriano Silva, Jiayi Dou, et al. Principles for designing proteins with cavities formed by curved  $\beta$  sheets. *Science*, 355(6321):201–206, 2017.
1628. Enrique Marcos, Tamuka M Chidyausiku, Andrew C McShan, Thomas Evangelidis, Santrupti Nerli, Lauren Carter, Lucas G Nivón, Audrey Davis, Gustav Oberdorfer, Konstantinos Tripsianes, et al. De novo design of a non-local  $\beta$ -sheet protein with high stability and accuracy. *Nature structural & molecular biology*, 25(11):1028–1034, 2018.
1629. Jingxue Wang, Huali Cao, John ZH Zhang, and Yifei Qi. Computational protein design with deep learning neural networks. *Scientific reports*, 8(1):1–9, 2018.
1630. Namrata Anand-Achim, Raphael R Eguchi, Irimpan I Mathews, Carla P Perez, Alexander Derry, Russ B Altman, and Po-Ssu Huang. Protein sequence design with a learned potential. *Biorxiv*, pages 2020–01, 2021.
1631. Joe G Greener, Lewis Moffat, and David T Jones. Design of metalloproteins and novel protein folds using variational autoencoders. *Scientific reports*, 8(1):1–12, 2018.
1632. Mostafa Karimi, Shaowen Zhu, Yue Cao, and Yang Shen. De novo protein design for novel folds using guided conditional wasserstein generative adversarial networks. *Journal of Chemical Information and Modeling*, 60(12):5667–5681, 2020.
1633. John Ingraham, Vikas K Garg, Regina Barzilay, and Tommi Jaakkola. Generative models for graph-based protein design. 2019.
1634. Yue Cao, Payel Das, Vijil Chenthamarakshan, Pin-Yu Chen, Igor Melnyk, and Yang Shen. Fold2seq: A joint sequence (1d)-fold (3d) embedding-based generative model for protein design. In *International Conference on Machine Learning*, pages 1261–1271. PMLR, 2021.
1635. William R Pearson. An introduction to sequence similarity (“homology”) searching. *Current protocols in bioinformatics*, 42(1):3–1, 2013.
1636. Nelson Perdigo, Julian Heinrich, Christian Stolte, Kenneth S Sabir, Michael J Buckley, Bruce Tabor, Beth Signal, Brian S Gloss, Christopher J Hammang, Burkhard Rost, et al. Unexpected features of the dark proteome. *Proceedings of the National Academy of Sciences*, 112(52):15898–15903, 2015.
1637. Ratul Chowdhury, Nazim Bouatta, Surojit Biswas, Charlotte Rochereau, George M Church, Peter Karl Sorger, and Mohammed N AlQuraishi. Single-sequence protein structure prediction using language models from deep learning. *bioRxiv*, 2021.
1638. Konstantin Weissenow, Michael Heinzinger, and Burkhard Rost. Protein language model embeddings for fast, accurate, alignment-free protein structure prediction. *bioRxiv*, 2021.