

# Genetic Algorithm and Particle Swarm Optimization Techniques for Inverted Pendulum Stabilization

S.Suganthi Amudhan, Dwivedi Vedvyas J, Bhavin Sedani

**Abstract:** *Inverted Pendulum is a popular non-linear, unstable control problem where implementation of stabilizing the pole angle deviation, along with cart positioning is done by using novel control strategies. Soft computing techniques are applied for getting optimal results. The evolutionary computation forms the key research area for adaptation and optimization. The approach of finding optimal or near optimal solutions to the problem is based on natural evolution in evolutionary computation. The genetic algorithm is a method based on biological evolution and natural selection for solving both constrained and unconstrained problems. Particle swarm optimization is a stochastic search method inspired by collective behavior of animals like flocking of birds, schooling of fishes, swarming of bees etc. that is suited to continuous variable problems. These methods are applied to the inverted pendulum problem and their performance studied.*

**Keywords :** *Particle Swarm Optimization (PSO) and Genetic Algorithm (GA), Evolutionary Computation (EC), Inverted pendulum, Fuzzy logic controller (FLC).*

## I. INTRODUCTION

Biological systems inspire lots of computational techniques like model based on human brain known as artificial neural networks and human evolution based genetic algorithms. Swarm intelligence is a type of biological system built on the collective behavior and interaction of the individuals in the environment.

Particle Swarm Optimization (PSO) and Genetic Algorithm (GA) are two popular methods for their advantages such as gradient-free and ability to find global optima [1].

Genetic Algorithm (GA) founded by John Holland in the early 1970s, involves operations like reproduction, crossover and mutation to optimize a given fitness value. The parameters to be optimized are represented as a string of chromosome.

Particle swarm optimization (PSO) developed by Dr. Eberhart and Dr. Kennedy in 1995 is population based and is motivated by social behaviour of bird flocking or fish schooling.

PSO is identical with Genetic Algorithms (GA) like random solutions are initialized and optimal values searched for, to update generations. Evolution operators like crossover

and mutation as found in GA are not available in PSO. Only few parameters are adjusted in PSO and hence it is easy to implement. PSO has applications in various areas like function optimization, artificial neural network training and fuzzy system control, just as in GA [2].

Hill climbing method is used, wherein it is able to preserve multiple solutions, removing unreasonable solutions. Using genetic operators, sometimes even weak solutions are part of solutions of further generations. The choice of right genetic operators gives us optimal solution of the search. Recombination results in having new solutions of high success rate owing to their parent's success. Generally high probability rate is given to crossover and low probability to be defined for mutation. Crossover helps in retaining the favorable aspects and removing undesirable components. Mutation sometimes due its randomness are likely to degrade the population rather than to improve it. GAs eliminate weak candidates during reproduction for that generation and also for its successive generations. This helps the algorithm to converge easily within a few generations.

Particle Swarm Optimization, Evolutionary Computation (EC) techniques and Genetic Algorithms are similar in randomly generated population and usage of a fitness value for evaluation. Random techniques are used to search for optimum and update the population. Global exploration is done using large inertia weight and small one helps in local exploration. No genetic operators like crossover and mutation are used in PSO, which differentiates it from EC & GA techniques. The particles in PSO update their internal velocity and so memory is needed for this storage. EC algorithms (such as evolutionary programming, evolutionary strategy and genetic programming) and PSO have different information sharing mechanism. In EC, the whole population is involved in sharing information with each other towards an optimal area whereas in PSO, only the 'best' particle gives the information to others. Here convergence to local best is faster than GA's and needs less parameters to tune.

## A. Genetic Algorithm

Genetic algorithm is search method involving natural selection and genetic operators [3]. They utilize operations like reproduction, crossover and mutation to optimize a given fitness value. The algorithm involves the following steps

1. Encoding of solution to the optimization problem as a binary string of chromosomes.
2. The initial chromosomes are randomly generated.

**Revised Manuscript Received on March 30, 2020.**

\* Correspondence Author

**S.Suganthi Amudhan\***, Assistant Professor, Electronics and Communication Engineering, Babaria Institute of Technology, Varnama, Gujarat, India.

**Dr. Dwivedi Vedvyas J**, Pro Vice Chancellor, C U Shah University, Wadhwan City, Surendranagar Gujarat, India.

**Dr. Bhavin Sedani**, Professor, Electronics and Communication Engineering, L.D. College of Engineering, Ahmedabad, Gujarat, India.

3. An objective function is used to evaluate the chromosomes assigning a fitness score.
  4. Universal sampling can be used to select members from the current population to produce offspring with no bias
  5. In the binary crossover mark, uniform crossover is performed and here the further generation is created by exchanging a particular gene between the parents.
  6. A specific probability of mutation is assigned to the bits of the chromosome.
- Steps 3 to 6 are repeated until convergence of criteria is achieved [4].

**B. Particle Swarm Optimization**

The algorithm of PSO as an evolutionary computation method is as follows:

1. Solution space to be defined and parameters to be optimized are to be selected.
2. Objective function is the fitness function defined for optimization.
3. The swarm location and velocities are initially defined.
4. After travel of the particles moved thru the complete solution space, particle fitness is calculated and compared with global best and personal best.
5. Evaluating particle fitness and compare the global best and personal best.
6. Using the relative pbest and gbest as in equation (1) and (2), updation of particles velocity is done.

$$v_{i,m}(t+1) = w \cdot v_{i,m}(t) + c1 \cdot \text{rand}() \cdot (pbest_{i,m} - x_{i,m}(t)) + c2 \cdot \text{rand}() \cdot (gbest_m - x_{i,m}(t)) \quad (1)$$

$$x_{i,m}(t+1) = x_{i,m}(t) + v_{i,m}(t+1) \quad (2)$$

$$i = 1, 2, \dots, n$$

$$m = 1, 2, \dots, d$$

where n is Number of particles in the group,

d is dimension, t is number of iterations,

$v_{i,m}(t)$  is Velocity of particle i at generation t

$$Vd_{min} \leq v_{i,d}(t) \leq Vd_{max}$$

w is the inertia factor,

c1 & c2 are acceleration coefficients,

rand() are random number between 0 & 1

$x_{i,d}(t)$  is the current position of the particle i at iterations

pbest Best previous position of the particle i

gbest best among all particles in the population

From Step 4, the procedure is repeated until the convergence criteria is met. The maximum number of iterations depends on the terminating criteria defined in the problem.

Genetic Algorithms (GA) are extensively proposed by researchers for tuning (optimizing) the Fuzzy Logic Controller (FLC). But when a comprehensive genetic tuning of an FLC is attempted, some critical limitations are encountered. Some researchers have proposed a novel approach for such optimization using the so called characteristic parameters of FLC. This details the application of such an approach using GA for designing an FLC for classical cart-pole problem. Results indicate that when a comprehensive tuning is not feasible, this approach is quite effective in yielding close-to-optimal FLC design using GA.

To apply GA to tune the parameters of a FLC, various designs are to be evaluated. This suggests usage of various combinations of parameters in large numbers and a relatively quick solution.

Since many design parameters have to be considered for construction of an FLC, a lengthy chromosome is required to encode all the design parameters. Moreover, owing to the different characteristics of each design parameter, encoding them into a chromosome is an extremely difficult problem. In most cases, therefore, optimization is performed only for the rule-table or the MFs [5].

The major design parameters of an FLC, which include the number and centers of the input/output MFs and linguistic control rules, can be represented by a few characteristic parameters. Use of these characteristic parameters can greatly simplify the FLC design procedure. Characteristic parameters are encoded as a chromosome which has been presented as an integer string [6]. The fitness function is evaluated by optimizing the chromosomes through genetic operations. As a result, we can obtain the optimal structure of FLC. The effectiveness of the proposed algorithm has been verified by simulating an FLC for a classical inverted pendulum.

Evaluation functions are used to calculate the fitness of parameters used to tune by GA. These parameters are then applied in the problem under consideration to see how well they are able to converge to the solution.

The SIMULINK model has the error in pole angle as well as the time taken for the pole to stabilize throughout the time specified as simulation duration. The simulation is stopped if the pole angle saturate, i.e. reach 90 degrees. Here the time taken is calculated by multiplying  $1 \times 10^9$  to the time taken before the pole collapsed due to saturation. This acts as a reward to keep the pole from collapsing a bit longer.

Fig 1 is the SIMULINK model used for design of Fuzzy Logic Controller for an Inverted Pendulum. The pole angle error and change in error are properly scaled by gains so that the result is between -1 to 1. These acts as inputs to GA and further the output received is also scaled by suitable gain, Impulse force applied outputs the pole angle, angular speed, cart position and its velocity.

**II. TUNING OF FLC USING GA**

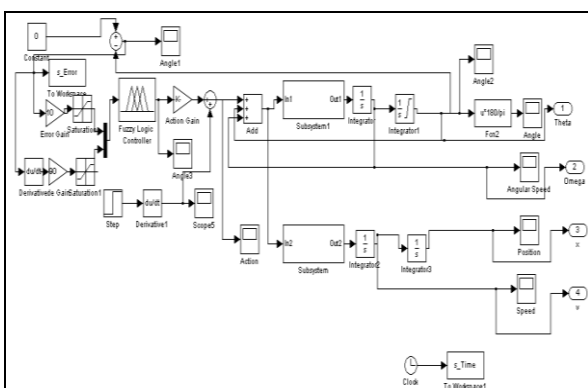

**Fig 1. Tuning of FLC using GA**

III. RESULTS

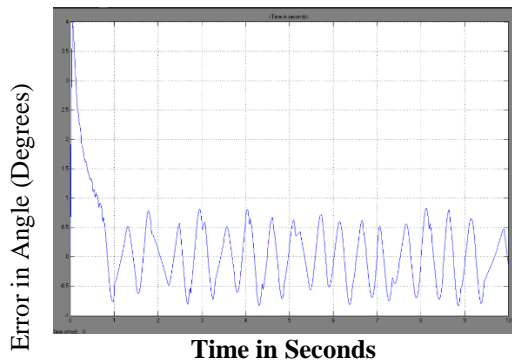

Fig 2. Performance with Impulse Input = 30 of a FLC without GA

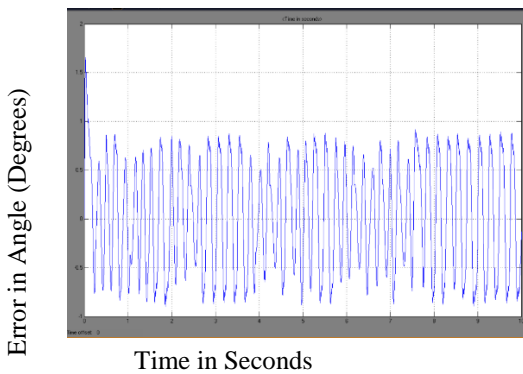

Fig 3. Performance with Impulse Input = 30 of a FLC with GA; No. Generations=15

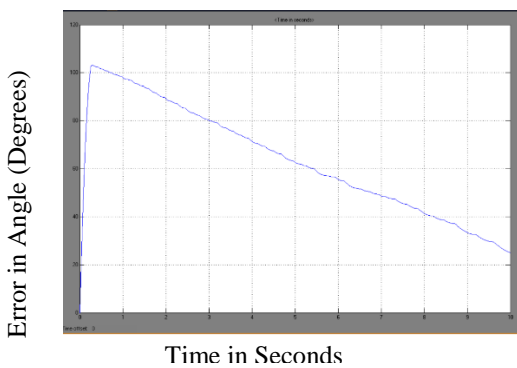

Fig 4. Performance with Impulse Input = 50 of a FLC without GA

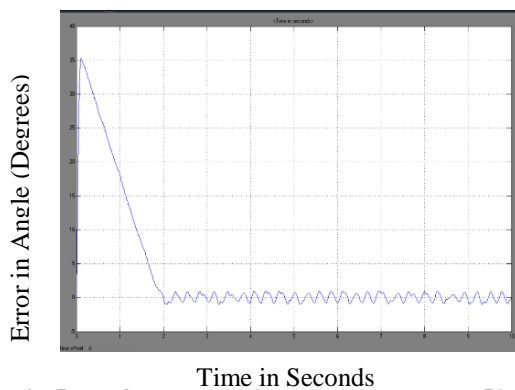

Fig 5. Performance with Impulse Input = 50 of a FLC with GA; No. Generations=15

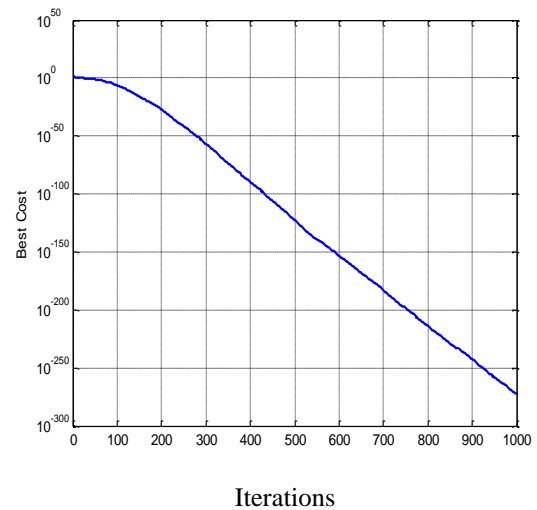

Fig 6. PSO result -Best cost vs Iterations

The simulation results arrived SIMULINK are indicated in the above figures Fig 2. To Fig 5. portrays the angle of the pole using manually-tuned FLC and genetically tuned FLC for each set of impulse inputs. To highlight the effect of increase in number of generations the simulation is done for two set of generations i.e. 30 & 50.

It can be clearly observed that as the force (impulse input) is increased the disturbance to the cart is more and hence angle of the pole as well as time taken for the pole to stabilize increases. When the force applied is beyond 60N it is very difficult to stabilize even if we increase the number of generations.

It can be seen that the fluctuations of the pole angle about the desired position are less with genetically tuned FLC, as compared with the manually tuned one. The fluctuations are also more smoothened for the genetically tuned FLC, which indicate improved relative stability.

PSO results for 1000 iterations are plotted with reference to cost function used in the program in Fig 6. It can be seen that the output (best cost) is exponentially decreasing with increasing number of iterations. The results are promising for the optimization problem chosen.

IV. CONCLUSION

The fuzzy logic controller design does not require explicit knowledge of the dynamics. So, it can be seen that this method of inverted pendulum stabilization provides accurate results even under ill-defined nonlinear dynamics.

PSO and GA are compared based on their ability to get optimal solutions and their computational efficiency. The proper selection and setting values of control parameters in these meta-heuristics is the key to success. Trial and error tuning is essential in optimization problems. Hybrid meta-heuristic approaches which can improve the quality of solution should also be thought out. The major issue is the selection of appropriate objective function.

Here the fuzzy logic controller is designed using characteristic parameters to define the chromosome of GA. It is observed that GA and PSO can be applied to a fuzzy logic controller designed for optimization of the objective function

i.e. keeping the deviation of the pole angle to zero degrees when impulse force is applied to the cart.

## REFERENCES

1. Kachitvichyanukul, Voratas. "Comparison of three evolutionary algorithms: GA, PSO, and DE." *Industrial Engineering and Management Systems* 11, no. 3 (2012): 215-223.
2. Hassan, Rania, Babak Cohanim, Olivier De Weck, and Gerhard Venter. "A comparison of particle swarm optimization and the genetic algorithm." *In 46th AIAA/ASME/ASCE/AHS/ASC structures, structural dynamics and materials conference*, p. 1897. 2005.
3. D.E.Goldberg, Genetic algorithms in search, optimization, and machine learning, *Addison-Wesley*, 1989.
4. Bäck, Thomas, David B. Fogel, and Zbigniew Michalewicz, eds. *Evolutionary computation 1: Basic algorithms and operators*. CRC press, 2018.
5. Harik, G., Lobo, F. and Goldberg, D.E., The Compact Genetic Algorithm. *Proceedings of the 1998 IEEE Conference on Evolutionary Computation*, pp. 523-528, 1998.
6. Park, Y. J., Cho, H.S., Cha, D.H., "Genetic Algorithm-Based Optimization of FLC Using Characteristic Parameters", *Proceedings of the 1995 IEEE International Conference on Evolutionary Computation*, pp 831-836, 1995.

## AUTHORS PROFILE



**Prof. S. Suganthi Amudhan** is working as an Assistant Professor in Electronics and Communication Department at Babaria Institute of Technology, Vadodara. She has a teaching experience of 15 years. She is currently a research scholar of C.U Shah University, Surendranagar.

She has received best paper presentation award once.



**Dr. Dwivedi Vedvyas J.** is working as Pro Vice Chancellor at C U Shah University, Wadhwan City, Surendranagar Gujarat, India. He is a Professor in Electronics and Communication Engineering at C.U Shah University and has total 23 years of experience including 5 years of industrial and 18 years of teaching experience. He has published/authored/co-authored several books, research/review articles/papers in refereed international/national journals/conference proceedings, successfully supervised 6 Ph.D. thesis (awarded), examined and reviewed many Indian Ph.D. thesis. He also has Indian patents; completed research and industry consultancy based projects, delivered many expert/keynotes talks.



**Dr. Bhavin Sedani** is working as a Professor in Electronics and Communication Department at L.D. College of Engineering (Government Engineering College), Ahmedabad. He has teaching experience of 17 years. He has presented more than 46 research papers in various international and national conferences. His 28 research papers are published in various international journals and Scopus indexed IEEE Xplore digital library. He has achieved best paper presentation awards 7 times for his research articles.