

Date of publication xxxx 00, 0000, date of current version xxxx 00, 0000.

Digital Object Identifier 10.1109/ACCESS.2020.Doi Number

# Relay-Assisted Technology in Optical Wireless Communications: A Survey

WENWEN LIU<sup>1</sup>, (Student Member, IEEE), JUPENG DING<sup>1</sup>, JIONG ZHENG<sup>1</sup>, XIFENG CHEN<sup>1</sup>, (Student Member, IEEE), CHIH-LIN I<sup>2</sup>, (Senior Member, IEEE)

<sup>1</sup>Key Laboratory of Signal Detection and Processing in Xinjiang Uygur Autonomous Region, School of Information Science and Engineering, Xinjiang University, Urumqi Xinjiang, 830046, China

<sup>2</sup>Green Communication Research Center, China Mobile Research Institute, Beijing 100053, China

Corresponding author: Jupeng Ding (jupeng7778@163.com)

This work was supported in part by National Natural Science Foundation of China (Grants No. 62061043), Natural Science Foundation of the Xinjiang Uygur Autonomous Region (Grants No. 2019D01C020), High-level Talents Introduction Project in Xinjiang Uygur Autonomous Region (Grants No. 042419004), Tianchi Doctor Program of the Xinjiang Uygur Autonomous Region (Grants No. 04231200728), Natural Science Foundation of Xinjiang University (Grants No. 62031224624), National Natural Science Foundation of China (Grants No. 61401420), and Postgraduate Research and Innovation Project of Xinjiang Uygur Autonomous Region (Grants No. XJ2020G063).

**ABSTRACT** When the distance between the source and the target is long, the signal will be affected by atmospheric turbulence, weather conditions and obstacles, which cannot support the information transmission. One of the existing solutions is to use relay-assisted technology (RAT). It makes the communications between the source and the destination possible under better channel conditions by setting up relay between the source and the destination. There are few comprehensive articles about relay-assisted technology in OWC. To fill this gap, this paper introduces the RAT of indoor optical wireless communications (IOWC), outdoor optical wireless communications (OOWC) and underwater optical wireless communications (UOWC) in different application scenarios, which has a better effect than direct communication between source and destination. The relay protocols, channel models, modulation techniques under three relay modes are reviewed. Finally, challenges of RAT in OWC are put forward and potential solutions are also given.

**INDEX TERMS** relay-assisted technology, optical wireless communications, indoor optical wireless communications, outdoor optical wireless communications, underwater optical wireless communications.

## I. INTRODUCTION

Go back to history, human beings have been using optical communication technology for a long time. For instance, the flame of a beacon tower is utilized to transmit messages. Optical wireless communications (OWC) is a wireless communication which uses light wave as the carrier, which combines with the characteristics of wireless communications and optical communications. OWC has shown great potential in applications where radio-frequency (RF) communications is prohibited [1].

As a mature technology, RF is widely utilized in many indoor, ground and space communications systems. However, the propagation characteristics of RF communications systems raise interference issues, which in turn affect frequency availability and thus capacity. First, the RF spectrum is controlled by local and international authorities to limit interference and ensure the normal operation and coexistence

of RF-dependent systems. With the increasing application of RF communications, RF spectrum becomes even more crowded and scarce, so the acquisition cost becomes higher and higher. A number of efforts have been achieved in research and industry to expand the capacity of existing wireless technologies (for example, to reduce interference) and to develop new technologies to meet emerging needs [2]-[4].

Fifth generation (5G) communications and beyond 5G (B5G) services attract widespread attention. Meanwhile they are expected to support service scenarios with multiple requirements, such as higher data rate, ultra low latency and large number of connections [5], [6]. Numerous researches deem that OWC is a potential solution to support the high data rate 5G filed due to its tremendous and value [1], [7]. OWC has multiple advantages such as huge spectrum resources, strong confidentiality, no spectrum authorization,

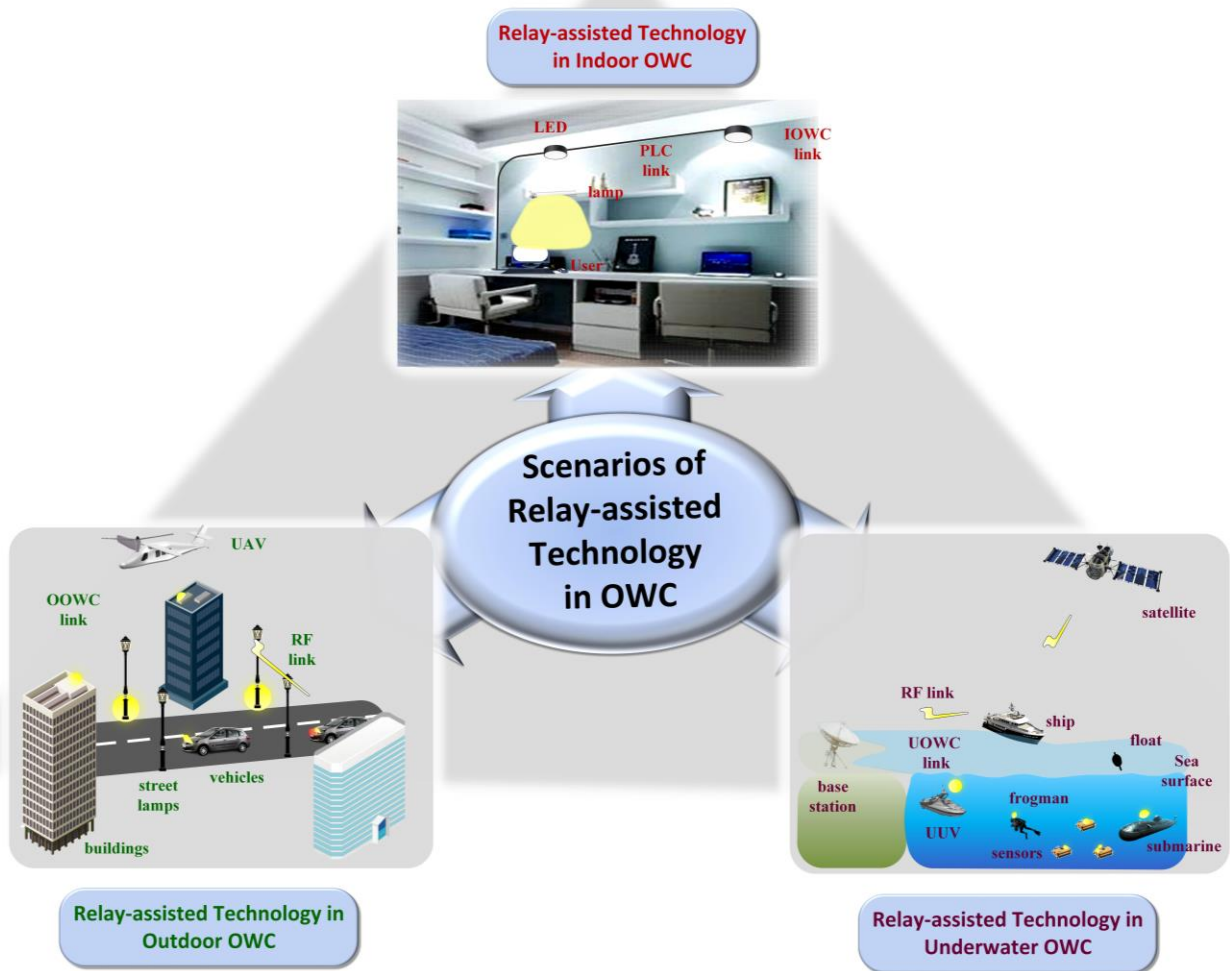

FIGURE 1. Application scenarios of relay-assisted technology (RAT) in optical wireless communications (OWC).

and immunity from traditional electromagnetic interference. The unlicensed spectrum and broadband at OWC reduce the pressure on RF communications. OWC is often applied not only for indoor communications, but also for outdoor applications, such as intelligent transportation systems and vehicle-to-vehicle (V2V) communications. In addition to its multiple advantages, OWC faces some challenges in the process of transmitting information. Relay-assisted technology (RAT) in OWC is introduced below, which is used to overcome the atmospheric turbulence.

RAT refers to improve the problems of information transmission interruption caused by obstacles in direct communication between source and destination by adding relay nodes. There are two common relay protocols: decode and forward (DF), and amplify and forward (AF) [8], [9]. The former is generally regarded as an analog signal processing mode. When using an AF scheme, the relay does not perform any decoding of the received signal, only simple measures the received signal and amplifies it to the destination. As for the latter, the received signals are detected,

evaluated and forwarded in this protocol, which is considered as a digital signal process mode. When DF scheme is adopted, the relay decodes the signal received from the source, and then recodes the information and transmits it. Owing to the uncorrelated relay channels, decoding and demodulation errors are easily caused with DF protocol. Furthermore, compared the two protocols, the complexity of AF equipment is lower than DF. In the process of signals transmission using AF protocol, noise is transmitted at the same time. However, in this way, the channels before and after the relay are relevant. Although DF protocol does not transmit noise, the front and back channels are not correlated, which is easy to cause decoding errors. The harm is far greater than the noise propagation by using AF protocol.

According to different application scenarios, OWC is divided into the following different categories: indoor optical wireless communications (IOWC), which is also called visible light communications, outdoor optical wireless communications (OOWC), also known as free space optical communications, and underwater optical wireless commun-

TABLE 1. List of Abbreviation.

Acronym	Description
5G	Fifth Generation
A2G	Air-to-Ground
AF	Amplify and Forward
APDs	Avalanche Photodetectors
AT	average throughput
ATP	Acquisition, Tracking, and Pointing
ASEP	Average Symbol Error Probability
AUVs	Autonomous Underwater Vehicles
BER	Bit Error Rate
CCI	Co-Channel Interference
CDF	Cumulative Distribution Function
DF	Decode and Forward
DPSK	Differential Phase-Shift Keying
ECC	Ergodic Channel Capacity
EDFA	Erbium-Doped Fiber Amplifier
EGC	Equal Gain Combining
HAP	High Altitude Platform
HST	High-Speed Train
IM/DD	Intensity Modulation and Direct Detection
IOWC	Indoor Optical Wireless Communications
LAP	Low Altitude Platform
LED	Light-Emitting Diode
LD	Laser Diode
LOS	Line of Sight
MAP	Medium Altitude Platform
MMW	Millimeter Waves
OOK	On-Off Keying
OP	Outage Probability
OOWC	Outdoor Optical Wireless Communications
OWC	Optical Wireless Communications
PIN	Positive-Intrinsic-Negative
PLC	Power Line Communication
PMT	Photomultiplier Tube
PPM	Pulse Position Modulation
RAT	Relay-Assisted Technology
RF	Radio Frequency
ROVs	Remotely Operated Underwater Vehicles
SER	symbol error rate
SNR	Signal-to-Noise Ratio
UAVs	Unmanned Aerial Vehicles
UWA	Underwater Acoustic
UOWC	Underwater Optical Wireless Communications
UWSNs	Underwater Wireless Sensor Networks
V2I	Vehicle-to-Infrastructure
V2V	Vehicle-to-Vehicle
VANET	Vehicular Ad-hoc Network

ications (UOWC). Nevertheless, OWC is not only suitable for indoor or outdoor high-speed data transmission, but also combined with the traditional communication technologies. That is, RAT is adopted to better realize information transmission, such as integrated power line communications (PLC) and IOWC, and the combination of UOWC and RF communications. As shown in Fig. 1, different application scenarios of RAT in OWC are presented, including RAT in IOWC, RAT in OOWC, and RAT in UOWC.

Recent years, researches of RAT in OWC have been comprehensively explored. A light intensity distribution model in an indoor RF sensitive environment is proposed in [10]. Where, IOWC technology provides downlink connection through a relay, using RF technology to connect to the base station (BS). The hybrid RF/IOWC system is also considered in [11], [12], which is to improve user data rates and interrupt throughput. In [13], non-orthogonal multiple access performance of IOWC downlink is studied from two aspects of coverage probability and traversal rate. The multi-hop performance of serial relay under scattering loss, atmospheric turbulence and absorption loss channels is studied, and the feasible transmission range and end-to-end bit error rate (BER) are obtained in UOWC [14]-[16]. Celik *et al.* analyzed the multi-hop transmission performance under AF and DF relay protocols, and obtained the influence of multi-hop connectivity on location and routing [17]. The combination of OOWC and RF systems has been researched for more than a decade [18]. There are two ways to achieve the mixing of OOWC/RF: mixed OOWC/RF system and hybrid OOWC/RF system. Their differences are described in [19], [20]. In addition, multi-hop system like mixed RF/OOWC/RF system is also proposed in [21], which is proposed to solve the problem of multi-user communications. Although this method guarantees the reliability of the system, the cost is high and the resources are wasted. In [22], the RF/OOWC system chooses the partial relay scheme maximize the instantaneous channel gain for the RF link.

This article is structured as following. Section II studies the different relay forms in OWC. Section III classifies the relay selection schemes in OWC. Section IV describes the construction of relay systems. Section V analyzes key technology for RAT in OWC. Section VI points out the challenges and potential solutions. Section VII draws the conclusion. To make it easier to understand, Table 1 gives the list of acronyms and their corresponding definitions.

## II. DIFFERENT RELAY FORMS IN OPTICAL WIRELESS COMMUNICATIONS

Fig. 2 shows the block diagram for classification of RAT in OWC. Furthermore, there are some different forms of relays that need to be introduced.

### A. RELAY FORMS IN INDOOR OPTICAL WIRELESS COMMUNICATIONS

As mentioned in [1], IOWC system used laser diode (LD) or light-emitting diode (LED) as transmitter. Due to the

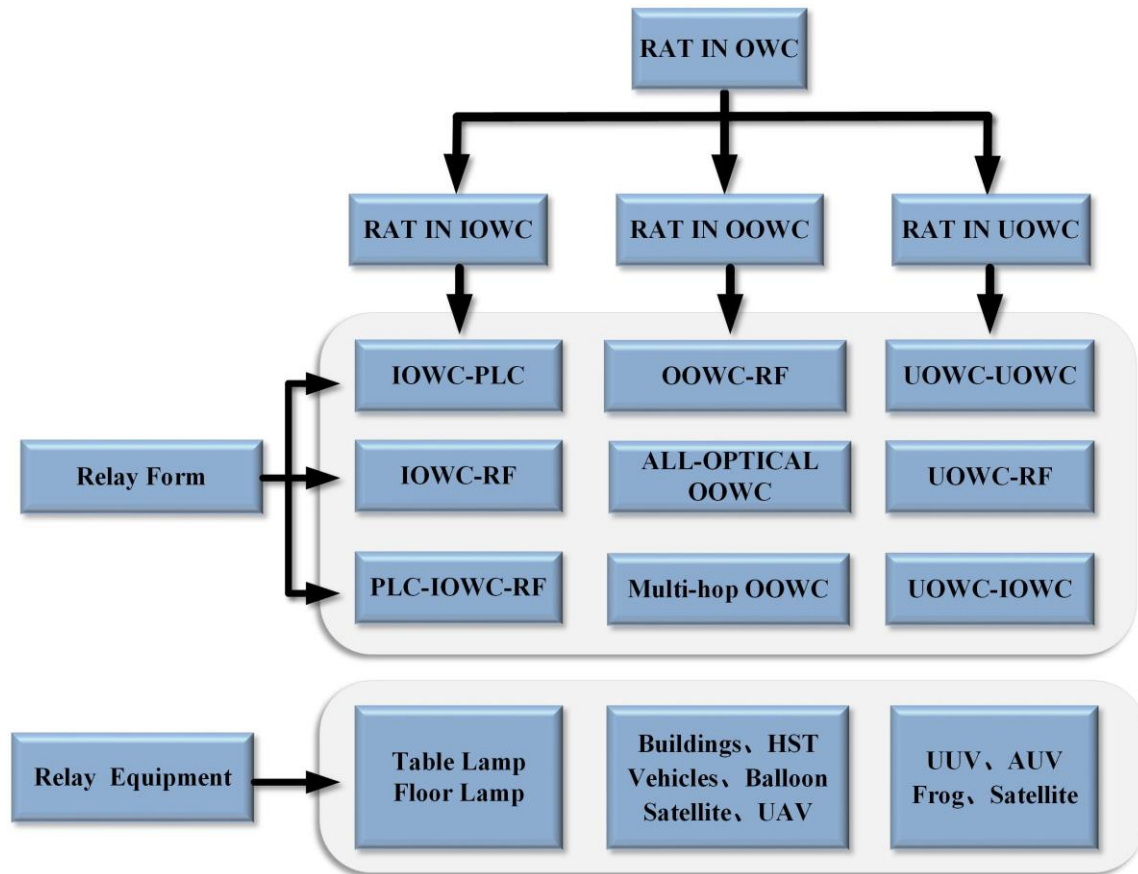

FIGURE 2. Classification of RAT in OWC.

coherent characteristics of laser, the light is concentrated and goes forward directly. Therefore, the distance of laser propagation is relatively long. Compared with LED, LD has higher direct modulation speed and better pumping efficiency, and there is no efficiency decline effect [23]. Two different ways of IOWC technology are introduced in references [23]-[26], namely, the performance of IOWC link under blue LDs using orthogonal amplitude modulation technology [23] and [24], and the development of near-infrared photonic colorless LDs in IOWC [25] and [26]. These two methods show that IOWC is superior to RF.

Y. Chi *et al.* in [23] took LD as the transmitting device, adopted 64 quadrature amplitude modulation and 32 subcarrier orthogonal frequency division multiplexing technology, realized IOWC based on Gallium nitride blue LD, and made the transmission rate reach 9 Gbps. Furthermore, they used Gallium nitride blue LD and compact white phosphor diffuser to fuse indoor white light and IOWC. Due to the high reflection and scattering absorption of the blue laser beam when passing through the phosphor diffusion film, the divergent blue laser beam reduces its throughput response by 24 dB [24]. The results show that the phosphor diffuser diverging gallium nitride blue laser diode has great development potential for future hybrid white light and IOWC system applications.

In addition, the millimeter wave wireless 16 quadrature amplitude modulation orthogonal frequency division multiplexing data communication with the original data rate of 4 Gbit/s can be realized by using the mm-wave over fiber link and the dual-mode colorless LD [25]. In 2016, C. Tsai *et al.* studied the hybrid architecture of 60 GHz millimeter wave fiber wireless access based on dual-mode LD [26]. The result shows that this architecture can directly cover the current optical and wireless networks and be used for the next generation indoor and short-range mobile communication. Although LD has great development potential for IOWC, LD can only be used for point-to-point communication, and communication will be interrupted when there are obstacles.

Therefore, using a LED as the light source, IOWC combines lighting with communications and transmits information using a high-speed light and dark flashing signal carried by the LED light. Compared with RF communications and OOWC, the advantages of IOWC are safe to human eyes and higher transmitting power [27]. In addition, it doesn't have the power consumption problem. The transmitters choose solid state lighting source [28]. As the supplement of RF communications, IOWC provides wireless coverage and make more users connect to the network [29]-[31].

Generally speaking, IOWC belongs to short distance communications [1]. It is generally acknowledged that the

communications distance range of indoor communication is approximately within 20 m [1], [2], [32]. And then LED IOWC technology uses visible light as the medium for information transmission, which has the double functions of lighting and communications, and has the advantages of free electromagnetic interference, no license verification, green environment protection, high confidentiality, lower cost, higher lifetime, energy savings, good compatibility and so on [32]-[35]. However, IOWC systems also face many challenges such as linear distortion, multipath interference and heavy backlight interference [34], [36].

### 1) PLC WITH RAT IN IOWC

For IOWC, PLC can supply power to the LED through the power cord and transmit information at the same time. IOWC is made up for the inadequacy of PLC mobility is poor, so as to realize the integration of the communications. PLC uses itself wires for communications, which has attracted wide attention due to its advantages such as no extra wiring, low cost, flexible access and wide coverage [37], [38]. One of the main advantages of using the PLC network is that it can reuse the existing wired grid to provide communications capability. Therefore, smart grid is still one of the most attractive applications of PLC, so the researches about this field are very extensive [38], [39].

An IOWC modem in a LED illumination lighting device may receive data from a power line powered by a PLC modem and then wireless cover an indoor area as an optical transmitter [40]. The system does not need to demodulate the signal of the power line, only needs to transmit according to the waveform of the transmitted signal as the LED lighting source. It is a very easy to synthesize technology to make the signals from power lines communications [41].

### 2) VANET COMMUNICATION WITH RAT IN IOWC

Vehicular ad-hoc network (VANET) is a widely studied for development of intelligent transportation system. The initial goal of the VANET is to convert all vehicles into communication nodes, and connect the vehicles into a wide range of wireless mobile network to communicate with each other by means of short distance direct communications. This cannot only improve traffic efficiency, but also bring reliable safety and multiple convenience to the vehicle. Traditional VANET uses RF to support vehicle-to-infrastructure (V2I) communication link, which has limited bandwidth and low power efficiency. Because the communications capability of IOWC access points (APs) are compatible with their original lighting capabilities, the cost of a deployable network is low [42]-[44]. Hybrid RF/IOWC systems achieve higher throughput than RF systems. However, the movement of the vehicles cause the link between the vehicles and the two APs to change.

Fig. 3 (a), (b) are the examples of V2V-IOWC model and V2I-IOWC model in [45]. The traditional VANET communications between vehicles using radio frequency technology. However, with the increase of vehicle density, RF-based VANET bandwidth limit will inevitably produce

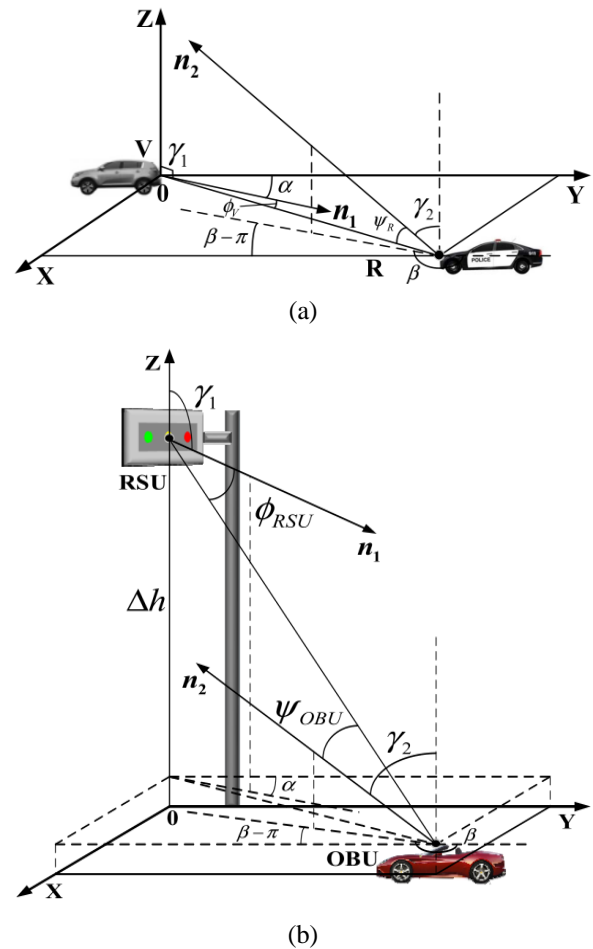

FIGURE 3. V2V-IOWC model and V2I-IOWC model. (a) V2V-IOWC model based on the position and the posture, and V2I-IOWC model based on the position and the posture [45].

interference. As a new candidate assistant technology, IOWC has the advantages of wide spectrum, high power efficiency and small interference, but it also has the disadvantages of limited communications range. Thus, the hybrid IOWC/RF structure is beneficial to the efficiency and reliability of VANET [46]. VANET relay is to establish wireless continuity of communications and the sharing and dissemination of information. The selection of relay nodes plays an important role in vehicle ad hoc networks, which will directly affect the system's channel capacity, relay probability and BER performance [47], [48]. Robust relay as communications between vehicles in the process of running, and to rely on the cooperation between vehicles to interact information, and to use relay transmission to ensure the an improved zonal broadcast protocol method can improve the overall performance of communications systems in dense scenarios [49], [50]. In order to solve the problem that there is no central node and the network topology changes rapidly, we can adopt cooperative relaying distributed time division multiple access method and use idle time slot to transmit data [51], [52]. In reference [53], the multi-hop link Model of vehicle is analyzed, the end-to-end outage probability is

studied, and the maximum hop number and the minimum transmit power are obtained. The power allocation problem of multi-hop relay systems under DF cooperation is studied [54]. Moreover, the relay mode adopted for high-speed moving vehicles is also different. The device-to-device vehicle communications relay based on speed clustering has a good performance [55]-[59], in the case of asymmetric vehicles, the vehicle communication system is maintained by a two-way relay system based on hybrid decode-and-amplify-forward [60], [61].

## B. RELAY FORMS IN OUTDOOR OPTICAL WIRELESS COMMUNICATIONS

OOWC is that modulated laser beams transmit optical signals through free space in wireless way [41]. It has multiple advantages, such as no electromagnetic interference, larger band-width, unlimited spectrum, high transmission rate, good anti-interference and anti-interception. Therefore, it is effectively supplement on RF communications. OOWC is suitable for any inconvenient laying of cable and cable interruption occasions. It can realize broadband access, base station interconnection, point-to-point dedicated link and network communications.

Despite the OOWC link has great potential, it still exist several serious loss, such as serious path loss effect, pointing error and the line-of-sight (LOS) requirements, as well as atmospheric damage, such as atmospheric turbulence and visibility conditions (including snow, fog and dust, etc. [41], [62], [63]). All of these damages result in unpredictability of link performance, which could lead to severe degradation of OOWC system performance, such as outage probability (OP), error probability, and ergodic capacity.

Pointing error caused by misalignment between transmitter and receiver is also a problem in OOWC system [1]. Meanwhile, in order to ensure the OOWC quality, the introduction of acquisition, tracking, and pointing (ATP) technology is necessary [64]. ATP technology involves acquiring a target at a wide range of angles and then tracking and pointing it in real time. In relay-assisted technology, the types of relay are usually classified as fixed (buildings, street lamps, etc.) and mobile (for instance vehicles, UAVs) relays.

### 1) BUILDING, VEHICLE AND BUILDING TO VEHICLE COMMUNICATIONS WITH RAT IN OOWC

RAT is used in building to building communications in [1] especially in big cities. There are so many of tall buildings that the direct communications between buildings is easy to be cut off by obstacles such as tall buildings.

Therefore, the introduction of relay technology is a feasible scheme. Choosing the right relay node can not only make the communications link transmit normally, but also improve the communications quality due to the shortening of the communication link from source to destination. In this way, the relay will select buildings or vehicle due to practical requirements.

The rest of the infrastructures is generally divided into fix-

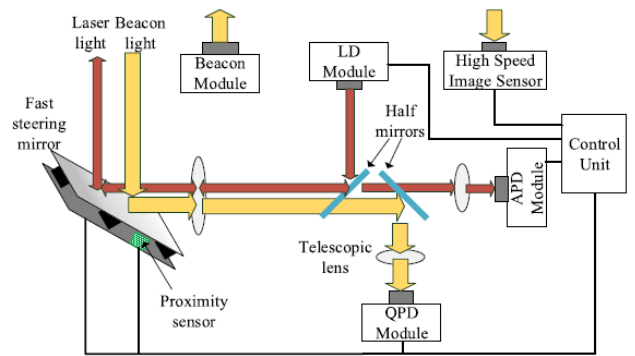

FIGURE 4. OOWC and HST communication [32], [68].

ed and mobile relays. In the urban intersection environment, when there are large buildings at the corner of the intersection, the communications link between the two vehicle terminals on the corner will have shadow fading [65], in view of this situation, the original information can be sent to a traffic camera by a Fountain code at the vehicle sending end and then transmitted to a traffic camera to receive the vehicle [66], because the signals sent by the source vehicle end arrive at the receiving end through the combination of direct transmission and relay transmission through roadside fixed facilities, and are independent of each other, the diversity effect can be obtained at the receiving end. This receiving method effectively alleviates the multipath effect and the influence of shadow fading in road environment. Moreover, the scattering loss of the intersection can be compensated by relay.

### 2) HIGH-SPEED TRAIN COMMUNICATIONS WITH RAT IN OOWC

Because trains move at high-speeds, they often suffer frequent switching in their communications to the ground. According to [67], OOWC is used between a train and a ground base station to provide stable high data rate communications due to its advantage of high optical bandwidth. Radio over fiber (ROF) has been proposed to avoid high deployment costs. It uses a fiber link from the roof antenna connected to the train control system, using cellular networks as a backhaul, on top of the train roof antenna and cellular network communications, and through the optical fiber sends the data to the wireless access point. The purpose of using roof antennas is to reduce the number of handoffs and maximize network capacity by keeping the channel conditions between the user and base station relatively fixed over a long period of time. This scheme reduces the packet loss rate of high-speed train (HST) communications and improve the network performance. Fig. 4 shows the OOWC and HST communications [32], [68]. As can be seen from the Fig. 4, it consists of a laser emitter, an optical receiver, an avalanche photodiode and a tracking mechanism. When the transceiver is fixed in a stable position, the laser emitter and APD are designed to achieve 1 Gbps data rate communication. The two-dimensional mirror

actuator is controlled by a control unit, which controls the direction of the mirror based on data from the high-speed image sensor and the quadrant photo detector of the telescope. In order to realize fast switching, high-speed image sensor is used to detect the laser beam transmitted to the adjacent ground station in laser train communication. Once the laser beam is redirected to a nearby ground station, the telescope's quadrant photo detector is used for precise tracking.

### 3) UAV COMMUNICATIONS WITH RAT IN OOWC

There introduce UAV air-to-ground (A2G) [69]. In aerial-terrestrial networks using millimeter-Wave (mmWave), UAV is used as an AF relay [70], [71]. To compensate the unpredictability of OOWC links, OOWC links can be combined with traditional RF communications. That is by introducing the relay-assisted technology to get a hybrid OOWC/RF link. RF link is mainly used to complement OOWC link. By reducing the communications distance, the influence of atmospheric turbulence on the system can be mitigated and improve the effectiveness and reliability of communications quality.

In hybrid OOWC/RF system, for OOWC link, Log-normal distributions, which is widely believed better under weak turbulence, Gamma-Gamma distributions, are generally regarded as optimal model in strong turbulence, Negative Exponential distributions, and Malaga distributions could be selected [72], [73]. For RF link, Rayleigh fading [21], Nakagami- $M$  fading [74],  $\eta$ - $\mu$  distributions [72], Rician fading [75] and  $M$  distribution [76] could be selected. In many cases, in the actual wireless environment test, Nakagami- $M$  distribution provides a better match with the actual test results than Rayleigh and Rician channels. It is investigated that RF links is subjected to the Nakagami- $M$  fading in the co-channel interference (CCI).

### 4) SATELLITE COMMUNICATIONS WITH RAT IN OOWC

According to [77], a hybrid satellite and OOWC cooperative system is proposed to receive the physical layer security. Satellite communications is that satellite as a relay station realize the transfer of data between point and point on the earth. The large number of satellites and ground stations required by the traditional satellite to directly cover the whole world or the poor real-time performance of the down transmission in operation. In order to achieve the data communications between the satellite and the ground station with a better transmission mode, the way of relay satellite communications has been proposed. There are some different scenarios about satellite communications under relay systems.

## C. RELAY FORMS IN UNDERWATER WIRELESS COMMUNICATIONS

Underwater wireless communications technology has become a major focus in recent years, which mainly includes RF waves, acoustic waves and optical waves [78], [80]. There is less absorption of mechanical waves in the acoustic band in the underwater environment, so underwater acoustic

wireless communications (UAWC) is generally regarded as the long-distance communications in recent years [64]. Since the multipath fading and speed of sound in water which is relatively slow, the underwater acoustic links have some delays. It is considered to be an advantage in the underwater environment based on the maturity of RF communications, the main applications are used in navy submarine. However, it requires very high transmission power, very large antenna, and very high frequency. Compared with acoustic and RF systems, UOWC supports higher data rates over distances of tens of meters, with little scattering in clear water. In addition, the UOWC system has low delay performance due to the high-speed propagation of light in aquatic media [79]. An underwater positioning scheme based on cellular network is proposed [80]. The network can serve as the infrastructure for centralized, decentralized and relayed aided underwater sensor networks for high-speed real-time monitoring.

UOWC is faced with such problems as limited communications range, large path loss [81]. RAT can be used to overcome these disadvantages. UOWC integration design is used to provide long-distance free space with underwater links [70]. Under this scenario, ships sailing at sea are used as relay terminals to communicate with underwater equipment after receiving information from land. In UOWC, the optical signal will be seriously affected by absorption and scattering. This is because in water, photons inevitably interact with water molecules and other particulate matter in water. Absorption and scattering will seriously weaken the transmitted optical signal and lead to multipath fading [77]. However, this is only compensated by increasing the incidence. If doing so, the transmission rate is large enough to have a certain sensitivity of the receiver, and increase the light intensity since turbulence of the atmosphere and ocean and drop will also reduce link performance over a wide range [71].

In order to better data transmission, underwater wireless sensor networks (UWSNs) are proposed [82]. They consist of distributed nodes such as subsea sensors, relay buoys, autonomous underwater vehicles (AUVs), and remotely operated underwater vehicles (ROVs). AUVs or ROVs receive data collected by sensors on the ocean floor and transmitted via optical links to transmit signals to ships, submarines, communications buoys or other underwater vehicles. These vehicles are then relayed to land via the UOWC link. Generally, underwater communications takes UOWC link as the primary link and RF link as the secondary link. Zeng *et al* introduced the UOWC in detail [78]. Aerial-to-underwater communications are realized in this method. In the process of the wireless network transmission, when unable to direct communications between source and destination, multi-hop technique is introduced. Under these communications, relay nodes are responsible for forward information. Since wireless link is easy to be affected by interference, noise and fading, the link quality that requires channel is more unstable, and the transmitted data is easy to

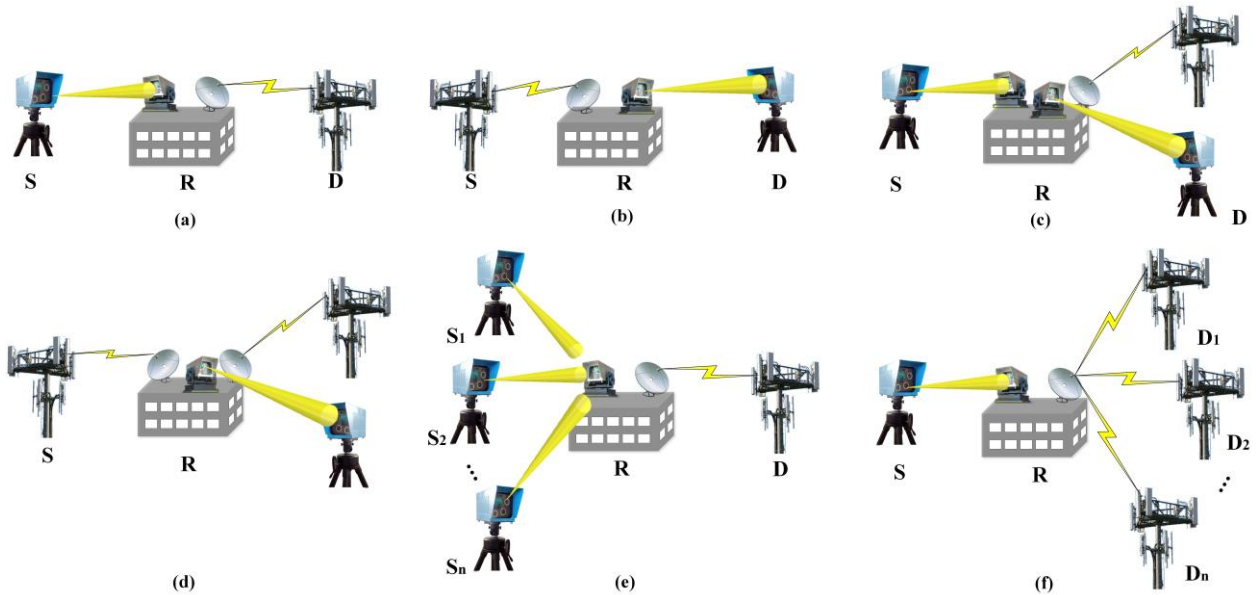

**FIGURE 5.** Different forms of dual hop RAT. (a) mixed OOWC/RF system, (b) mixed RF/OOWC system, (c) mixed OOWC and hybrid RF/OOWC system, (d) mixed RF and hybrid RF/OOWC system, (e) MISO mixed OOWC/RF system, (f) SIMO mixed OOWC/RF system.

be lost or wrong. The probability of data loss or error in multi-hop wireless network is much higher than that in single-hop wireless network. As a kind of effective way, retransmission method will ensure the reliable transmission of wireless communications. After the receiver obtains several independent branch signals, diversity gain could be obtained by combining techniques. The merging methods are mainly divided into: maxima ratio combining (MRC), equal gain combining (EGC), selection combining or switching combining (SC). In [74], [83], [84], SC has lower complexity and cost than the other two methods. Using relay-assisted technology can further improve the capacity and availability of optical wireless [8]. Broad application of IOWC is in hospital [84], [85]. OOWC communications has a wide range of applications, such as aerial, underwater and terrestrial communications [84].

### III. RELAY SELECTION SCHEMES IN OPTICAL WIRELESS COMMUNICATIONS

In this section, different relay selection schemes in OWC are discussed. Fig. 5 shows the different forms of dual-hop relay-assisted technologies, which take into OOWC as examples. Where, Fig. 5 (a) and (b) represent the two forms of mixed relay technologies in [62], [74]-[76]. Fig. 5 (c) and (d) stand for the different hybrid RATs in [86], [87]. Where, in Fig. 5 (c), one of the two links from relay to destination is used to backup link to cope with adverse effects such as bad weather. Unlike Fig. 5 (c) and (d) in the relay terminal to use RF link as secondary link, Fig. 5 (e) and (f) expound the different forms of multi-input and multi-output (MIMO) technologies, which select multiple links from source to destination to improve communications quality [88].

### A. RELAY SYSTEMS COMBINED WITH OTHER MODES OF COMMUNICATIONS

#### 1) INTEGRATION OF RAT IN IOWC

M. Uysal *et al.* analyzed the source-to-destination (S→D) link, source-to-relay (S→R) link and relay-to-destination (R→D) link [89]-[91]. The power delay profiles of direct link (S→D link) is larger than the S-R link or R-D link. This is why RAT is used for communications.

In order to coordinate the transmission between the RF network and the hybrid PLC/IOWC network, two parallel communications links of the power distribution are studied, including the cascaded PLC/IOWC link and the RF communications link [92], [93]. In [94], there is a mixed OOWC/IOWC system, which OOWC link is at the backhaul link. IOWC system is connected to OOWC links through DF relay. In the first time, Ding *et al.* analysis of outdoor IOWC links for satisfactory coverage introduced actually LED light beams into the design and uniformity [95], [96]. The hybrid OOWC/IOWC heterogeneous interconnection network is proposed in [97], which has better performance for broadband wireless communications in conditions of RF-sensitive and security-required.

- **IOWC-PLC relay system.** PLC uses power line as the medium for transmission, because of its good performance, no extra wiring, so it is widely used. And integrated network in PLC and IOWC makes IOWC more easily to access to the Internet [98]-[101].

At present, the integrated PLC/IOWC system has attracted researchers' wide attention. Two common types of relaying systems are AF and DF. In the former, the PLC signal brought to the LED array can be demodulated and decoded, then recoded and modulated for





**FIGURE 6.** Experimental campaign: a standard traffic transmits IOWC signal to a photo-receiver stage equipped with digital active decode and relay block [106].

IOWC transmission. In the latter, the analog PLC signal plus the noise component will be amplified directly and then retransmitted by the IOWC transmitter [40].

- **IOWC-RF relay system.** Dual-hop heterogeneous IOWC/RF communication system expands the coverage of IOWC system. In addition to detecting information through the IOWC link, the relay can also extract the DC component of the received optical signal, obtain energy from the first-hop IOWC link, and use the collected energy to retransmit data to the mobile terminal via the second-hop RF link [102]. In [103], the model of dual-hop mixed RF-IOWC system is provided to the end user by the IOWC access point with support of the multiple backhaul RF links.
- **PLC-IOWC-RF relay system.** The main defect of IOWC technology is the performance degradation under LOS path missing. RF communications has higher penetration capability, which can overcome the above deficiencies. In fact, the PLC technology can be integrated with the wireless network also has been put forward in a variety of scenarios. So the PLC technology integrated into the wireless relay system, can realize long-distance data transmission [92], [104]. In [105], a hybrid PLC/IOWC/RF front-haul with a fiber-based wired backhaul system to support a large number of smart devices (SDs). Due to the AP based on signal-to-noise ratio (SNR) association and bandwidth (BW) assigned to each SD will not necessarily improve system capacity, so they propose a new and effective AP association and BW allocation strategy, in order to maximize the total rate of hybrid system capacity (SRC).

From Fig. 6, a personal computer and an oscilloscope form a data acquisition unit. The distance between the transmitter and receiver is up to 50 meters through the limitation of the available lines in the sight length of the building [106]. RF and IOWC parallel systems with PLC as a kind of promising architecture, can increase the speed and reliability of the wireless network

## 2) INTEGRATION OF RAT IN OOWC

- **OOWC-RF relay system.** There are plenty of previous works analyzing the channel models about OOWC links and RF links in mixing of OOWC and RF systems. Table 2 lists some research about dual-hop of OOWC in these years. Where, ABER stands for the average bit error rate, AC represents asymptotic, ASER is average symbol error rate, ASEP represents average symbol error probability, AT is for average throughput, BER is bit error rate, EC is ergodic capacity, ECC stands for the ergodic channel capacity, OP represents outage probability, and SER is for symbol error rate. As can be seen from Table 2, the measurement criteria of OOWC and RF system are mostly OP and BER.

The application of 5G oriented transportation network needs larger coverage and more efficient communications mode. However, in large space, obstacles, complex terrain, bad weather and other interference factors may lead to poor quality or unavailability of communications links. At this point, it is difficult to meet the communications demand only by vehicle ad hoc network or fixed relay. Unmanned aerial vehicles (UAVs), satellites and other space nodes are widely used as relays [126].

UAV is an unmanned aircraft controlled by radio remote control equipment and its own program control device, which is considered the next possible solution in the transportation field [111]. There are some researches about using UAVs as relay-assisted system.

UAV communication is less affected by channel fading and easy to communicate with vehicles. The long vertical line-of-sight channel has a relatively reliable space-ground. Then, the UAV can be flexible deployment and move freely in three-dimensional space, which makes it easier to convert multi-hop forwarding into single-hop relay, reduce the communications delay and improve transmission reliability.

According to the [41], UAVs can apply in low altitude platform (LAP), medium altitude platform (MAP), and high-altitude platform (HAP). After receiving the signal transmitted by the transmitting terminal through the OOWC link, the UAVs use the wireless network to transmit the signal to the receiving terminal. In [112], RF link uses the Rician distribution in the presence of a LOS path or Rayleigh distribution in the absence of a LOS path. Based on the mentioned above, it is possible to realize long distance communications in mountain areas with multiple UAVs.

TABLE 2. DUAL-HOP OOWC-RF systems [67], [107]-[125].

Relay methods	Year	Channel model		Protocol	Performance Metrics
		First hop	Second hop		
Hybrid RF/OOWC	2013	RF: Rician	OOWC: Gamma-Gamma	AF	ASER
Mixed RF/OOWC	2013	RF: Rayleigh	OOWC: $\mathcal{M}$ - distributed	—	OP
Hybrid RF/OOWC	2013	RF: Rayleigh	OOWC: Gamma-Gamma	AF	OP, ABER, EC
Mixed RF/OOWC	2014	RF: Rayleigh	OOWC: Gamma-Gamma	DF	OP, ASEP
Mixed RF/OOWC	2015	RF: Rayleigh	OOWC: $\mathcal{M}$ -distributed	AF	OP, SER, AC
Hybrid RF/OOWC	2015	RF: Rayleigh	OOWC: $\mathcal{M}$ -distributed	AF	ASER
Mixed RF/OOWC	2015	RF: $\kappa$ - $\mu$ or $\eta$ - $\mu$	OOWC O: Gamma-Gamma	—	OP, BER
Mixed RF/OOWC	2015	RF: Nakagami-m	OOWC: Gamma-Gamma	AF	OP, ABER, AC
Hybrid OOWC/Rf	2015	OOWC: Gamma-Gamma	RF: Nakagami-m	—	OP
Mixed RF/OOWC	2015	RF: Rayleigh	OOWC: Gamma-Gamma	AF	OP, ABER
Hybrid OOWC/Rf	2015	OOWC: Gamma-Gamma	RF: Nakagami-m	AF	OP, ABER, ECC
Mixed RF/OOWC	2015	RF: $\eta$ - $\mu$	OOWC: Gamma-Gamma	AF	OP
Hybrid RF/OOWC	2016	RF: Raleigh	OOWC: Gamma-Gamma	—	AT
Mixed RF/OOWC	2016	RF: Raleigh	OOWC: Gamma-Gamma	AF	OP, ASEP, ECC
Hybrid RF/OOWC	2017	RF: Weibull	OOWC: Måaga $\mathcal{M}$	—	ASER
Mixed RF/OOWC	2017	RF: Rician	OOWC: Måaga $\mathcal{M}$	AF	OP, ABER, AC
Mixed OOWC/Rf	2017	OOWC: Nakagami-m	RF: Exponentiated Weibull	DF	OP, ABER
Hybrid RF/OOWC	2017	RF: Rician fading	OOWC: Gamma-Gamma	—	AT
Mixed OOWC/Rf	2017	OOWC: Måaga $\mathcal{M}$	RF: Nakagami-m	AF	EC
Hybrid RF/OOWC	2019	RF: Raleigh	OOWC: Gamma-Gamma	AF	AC

Of course, UAVs cannot handle emergencies. When a strong signal interference, easy to cause the receiver and ground workstation lost contact. This is that needs to be considered in the future work. In addition, the endurance of UAVs is also a key issue to be considered. One application of UAV-assisted OOWC systems is that in dense cities with tall buildings, UAV can be used as air relay to connect source and target nodes when the source-to-target connection is interrupted by tall buildings [69], [127]. And they also propose relay-assisted transmission for improving the performance of the centralized sensor network.

- **A2G-OOWC system.** There introduce UAV A2G [44], [69]. In aerial-terrestrial networks using millimeter-Wave (mmWave), UAV is used as an AF relaying [70], [71]. Generally speaking, electromagnetic waves in the frequency domain of 30-300 GHz (wave-length 1-10 mm) [128] are called mmW.

The communications performance of UAVs as relays in 5G networks is evaluated [129]. Compared to fixed facilities, UAVs are less affected by atmospheric fading, are more likely to establish long-term LOS links with vehicles, and have relatively reliable A2G connection channels [130]. Second, UAVs can be flexibly deployed within the three dimensional (3D) and move around freely. In [131], Abdull and others

have solved the problem of how to make the energy efficiency of the access node the highest in UAV auxiliary network by using the potential game theory. A wireless system consisting of ground terminals and UAVs is studied, and a periodic multiple access mechanism is proposed, the communication between UAV and ground terminal is scheduled in a periodic time division method based on UAV position, and the time allocation of different ground terminal is optimized to maximize its minimum throughput [46], [132].

- **OOWC with optical fiber system.** OOWC can be used in power over fiber (POF) and fiber bragg grating(FBG) sensors application [133]-[135]. They introduced the wireless optical technology into the wireless transmission of high-voltage transmission line sensor signals, and conducted experiments on the sensitivity of the wireless optical sensing transmission system to lateral deviation. The experimental results show that improving the wireless optical sensing transmission system has important practical significance for reliability and reducing the frequency and duration of link interruption under harsh outdoor environments such as high temperature and high wind.

### 3) INTEGRATION OF RAT IN UOWC

Table 3 compares the three different modes of underwater communications in [77], [136]-[138]. According to Table 3,

TABLE 3. Different modes of underwater communications [77], [136]-[138].

Different UC forms	Propagation distance	Antenna size	Speed	Date rates	Latency	Transmission size	Transmitter power	Effect factors
RF	<100m	0.5m	$2.25 \times 10^8$ m/s	Mbps	Modern	Few mW to hundreds of Watts	100W	Frequency conductivity, Bulky, costly and energy consuming transceivers
Acoustic	<20km	0.1m	1500m/s	Kb/s	High	Tens of Watts	10W	Multipath, doppler, temperature, pressure, Salinity, and sound noise
Optical	100-200m	0.1m	$2.25 \times 10^8$ m/s	Mb/s	Low	Few Watts	1W	Light scattering, ambient light noise, and line-of-sight communications



FIGURE 7. Underwater demanding long-distance, high transmission speed, and large data rate wireless communications [139].

these three modes all have their defects. Hence, the RAT in UOWC can be considered like Fig. 7 in [139]. The ship as the relay, receives the information from satellite, and transmits it to the float, submarine and frogman etc to achieve the space-to-air communications. In addition, when the AUV accomplished the underwater detection, the plane as the relay can receiver the data and then back to the base station on the ground. In this way, effective ocean monitoring can be achieved.

- **UOWC-OOWC relay system.** A dual-hop relay network is considered in [140], which is sufficient to reliab-

ly transmit underwater data over long distances without expensive and complex networking infrastructure. Under this scenario, multiple sensors transmit the data to relay in DF protocol by using UOWC link. The relay uses the OOWC link to transmit the optimal signal to the ground destination. In case of weak turbulence conditions, the UOWC and OOWC follow the log-normal distribution.

- **RF-UOWC relay system.** In [141], a dual-hop RF-UOWC system is considered. The information (such as commands or weather messages) is transmitted by source to the destination through an AF relay. The link

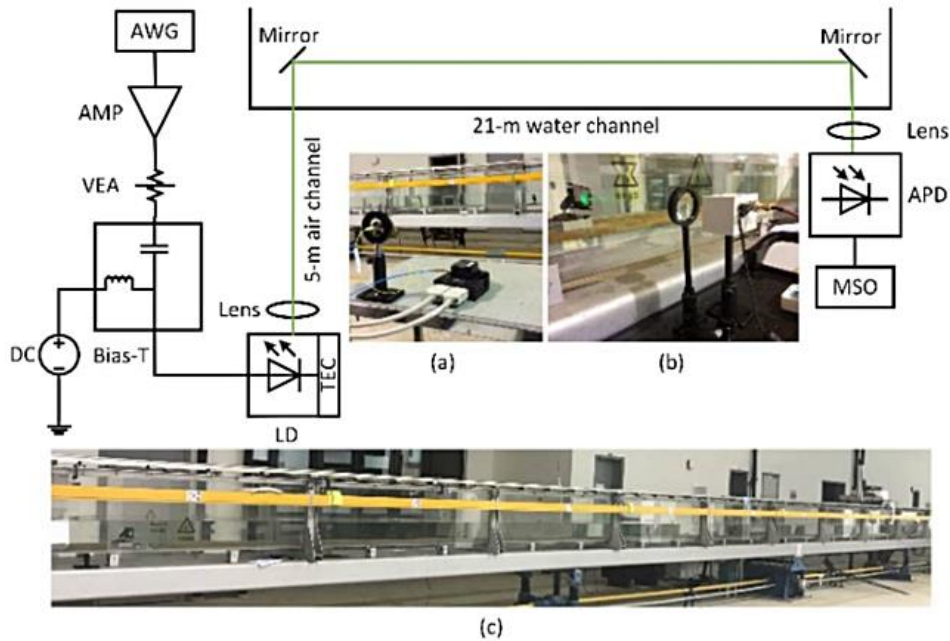

**FIGURE 8.** Experimental setup of the air-water laser communication scheme. (a) the transmitter module, (b) the receiver module, and (c) the water tank [142].

of RF obeys Nakagami- $m$  fading, and UOWC link is the mixture Exponential-Generalized Gamma fading.

There is an experiment about MIMO-OFDM-based UOWC system. The inset shows the schematic arrangement of transmitters and receivers [142], [143]. Xu did the experiment about air-water laser communication scheme, as is shown in Fig. 8. Where, (a) is the transmitter module, (b) stands for the receiver module, and (c) is for the water tank [142].

- **MULTI-HOP relay system.** The purpose of multi-hop UOWC relay system is to divide the total communications distance into shorter communications distance, and the influence of each communications distance is greatly reduced, so as to significantly improve the system performance or increase the feasible communications distance without increasing the total transmitted power [144]. Multi-hop transmission can significantly improve the system performance and extend the feasible end-to-end communications distance.

## B. RELAY SELECTION IN OPTICAL WIRELESS COMMUNICATIONS

There are two methods about relay-assisted technology: one-way relay system and two-way relay system. The two-way system is that the transmission of signals from the source to the destination is unidirectional, which may cause the loss of spectral efficiency [81]. Unlike the former, two-way relay system transmit the signals from the source to the destination is bidirectional, which improve spectrum utilization rate [81].

### 1) TWO-WAY RELAY SYSTEM IN OOWC

Two-way multi-hop of DF relay system modeling compared

with the one-way multi-hop system and the two-way dual-hop system [81]. The results show that the performance of the two-way multi-hop system is improved obviously.

### 2) TWO-WAY RELAY SYSTEM IN UOWC

Both of the above three conditions are one-way relay, which may cause the loss of spectral efficiency [81]. It considers the effect of absorption, scattering and ocean turbulence, based on two-way multi-hop of DF relay system modeling [81]. The results show that the performance of the two-way multi-hop system is improved obviously compared with the one-way multi-hop system and the two-way dual-hop system.

## C. ALL-OPTICAL RELAY SYSTEM IN OPTICAL WIRELESS COMMUNICATIONS

Different from the mixed of OOWC and RF system, in the all-optical OOWC relay system, the all sub-link from source to destination are light links. In the process of communications between source and destination, single-hop link is that information is transmitted via a link between the source node and the destination node in OWC, which is also called direct link. In this way, if there are some barriers in the direct link, the communication will be cut off. Hence, it is critical to consider choosing the option of adding relay nodes in the direct link.

### 1) DUAL-HOP LINK IN OWC

The dual-hop is that there is a relay node between the source node and the destination node in OWC. Fig. 9 shows the different relay forms about all-optical OOWC systems [145]-[149]. The basic form of the dual-hop is as shown in Fig. 9 (a). In [145], the all-optical dual-hop OOWC link is proposed, which is to better realize the effectiveness and reliability of communications. Relay configurations have two

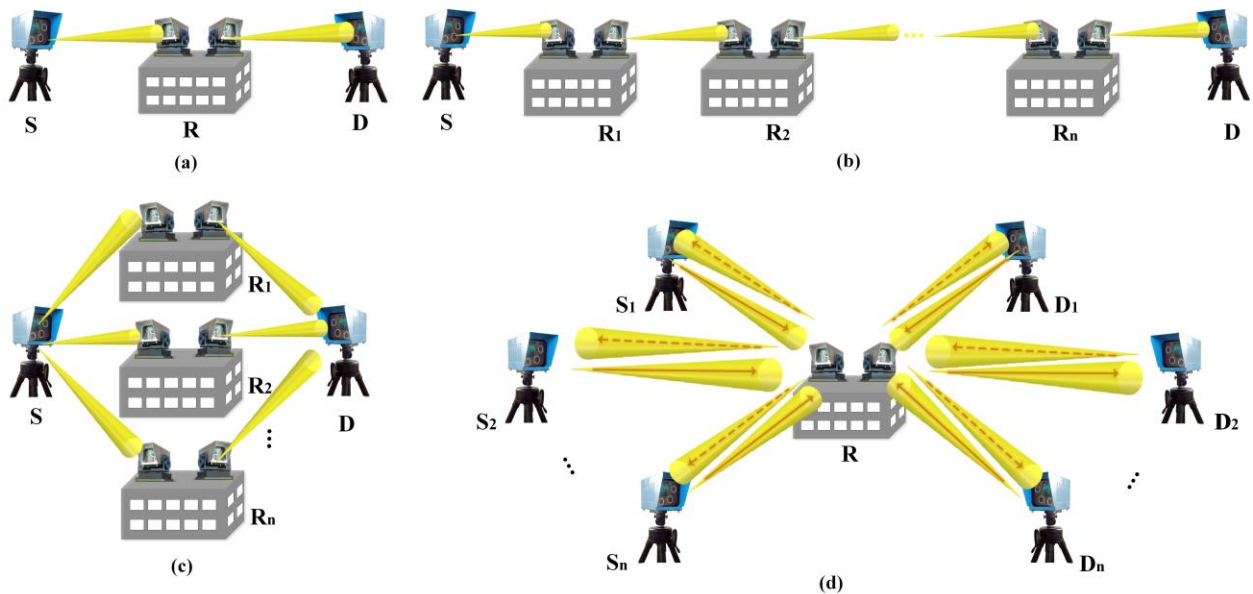

**FIGURE 9.** Different forms of all-optical relay-assisted technology systems. (a) dual-hop OOWC system, (b) serial OOWC system, (c) parallel OOWC system, (d) MIMO two-way OOWC system.

ways: serial (that is, multi-hop transmission) and parallel (namely are some barriers in the direct link, the communications will be cut off. Hence, it is critical to consider choosing the option of adding relay nodes in the direct link. Different from the mixed of OOWC and RF system, in the all-optical OOWC relay system, the all sub-link from source to destination are OOWC links. cooperative diversity) relays in [2]. The former like Fig. 9 (b) are often used to extend transmission range when transmission range is limited [146]. In this method, the signal in a serial way from a relay node to the next relay node. For latter, source node transmits data to relay node, which in turn retransmits the data to destination node. This form of transmission serves as a distributed array antenna and is considered a method of cooperative diversity [147], [148], as shown in Fig. 9 (b).

## 2) MULTI-HOP LINK IN OWC

Multi-hop means that there are multiple relay nodes  $n$  ( $n > 1$ ) between source node and the destination node in OWC. And the location of the rely node is also different. Serial relay OOWC system, as shown in Fig. 9 (c), means that there is only one link from the source to the destination, but this link contains multiple relay nodes. Similarly, parallel relay means that there are multiple different paths from the source end to the destination end, and each path includes a relay node, as shown in Fig. 9 (d).

## D. APPLICATIONS IN OPTICAL WIRELESS RELAY COMMUNICATIONS

Emergency communications requires fast response speed, elimination of faults in a short time and restoration of

services. The best way of emergency communication is the field of optical cable fusion, not only repair the speed is fast, and the effect is good. But for earthquakes, mudslides, landslides, bridges and other sites, this method is obviously not suitable. At this point, the application of OOWC to achieve emergency communications, can quickly restore communication, get good transmission effect, restore high bandwidth signal.

Paper [150] point out the advantages of using UAVs as air base stations. Aerial base stations are higher in height and more likely to be connected to the line of sight of ground users than ground base stations. In addition, UAVs can play an advantage in emergency communications by providing fast, reliable and economical network access to areas with inadequate ground network coverage, which is suitable for different rescue scenarios and missions [150], [151].

## IV. CONSTRUCTION OF RELAY SYSTEM IN OPTICAL WIRELESS COMMUNICATIONS

A complete communication system based on RAT includes source terminal, relay terminal, destination terminal and channel [144]. The channel model is of significance for analyzing the performance of the receiver terminal.

### A. SOURCE TERMINAL IN OPTICAL WIRELESS COMMUNICATIONS

The two most commonly used light sources in OWC are LED and LD. At the source, it is mainly to modulate the light source and transmit the data. This is because the effect of LED is similar to an antenna in traditional RF systems [152]. Space optical communication has the characteristics of large space loss and long transmission distance, so it is necessary

to select laser with high output power and high modulation rate. LD [153], [154] has the advantages of high efficiency, simple structure, small volume, light weight and can be directly modulated, thus it can be used as the light source of many existing space optic communications systems. In general, LED has lower thermal resistance than LD and therefore emit more power. Furthermore, LD has a maximum power output of 70 mw. By and large, there are two kinds of wavelengths selection: 780-800 nm and 1300-1500 nm [154]. The power of the infrared light wave equipment with a wavelength of 1550 nm is relatively large. The equipment can not only increase the transmission distance, but also improve the data transmission rate. In addition, most of the 1550 nm infrared light is absorbed by the cornea and does not reach the retina. Therefore, the power, transmission distance and visual security advantages of the optical wave equipment with a wavelength of 1550 nm are gained.

### B. RELAY TERMINAL IN OPTICAL WIRELESS COMMUNICATIONS

The relay realizes the conversion of photoelectric signals. Optical amplifiers are divided into fiber amplifiers and semiconductor amplifiers. At the relay, the photoelectric converter receives optical signals and converts them into electrical signals for RF link transmission. When relay transmits the signal to the destination, it is generally assumed that white additive Gaussian noise (WAGN) exists in the channel.

Due to the scattering and absorption in the atmosphere channel, light intensity to reach the relay is very weak, so photodetector is needed. There are two types of photo-detectors commonly used in OWC links: positive-intrinsic-negative (PIN) Photodetectors and avalanche photo-detectors (APDs). The former has a high response frequency, which can be up to 10 GHz. Moreover, it has the fast response speed and low power supply voltage. By contrast, the latter has high sensitivity and fast response. However, it needs hundreds of volts, and its performance is related to the power of incident light. When the incident light power is large, the noise caused by the gain is large, resulting in current distortion. Compared with APD, photomultiplier tube (PMT) has higher sensitivity and stronger photoelectric conversion capacity, but it is large in size, high in power consumption, and difficult in miniaturization.

The relay realizes the conversion of photoelectric signals. Optical amplifiers are divided into fiber amplifiers and semi-conductor amplifiers. At the relay, the photoelectric converter receives optical signals and converts them into electrical signals for RF link transmission. In [75], the OOWC link system model adopts the intensity modulation and direct detection (IM/DD). It directly detects the envelope of the intensity modulated optical carrier wireless signal. In other words, the intensity modulated signal will be recovered directly through the photodetector. The performance of OOWC depends on the signal-to-noise ratio (SNR).

### C. DESTINATION TERMINAL IN OPTICAL WIRELESS COMMUNICATIONS

The relay receives the transmitted signal and sends it to the destination via the RF link. In RF link, the milli-meter waves discussed. Generally speaking, electro-magnetic waves in the frequency domain of 30-300 GHz (wave-length 1-10 mm) [155] are called milli-meter waves.

According to the connection way of communication link, it can be divided into two types:(1) point-to-point connection, where the links only connect two nodes;(2) Multipoint connection refers to how many ( $n>2$ ) nodes are connected by one link. Whether it is a two-node or multi-node connection, the receiving terminal can discuss wired connection and wireless connection.

- **Wired connection.** It is the connection of receiving terminal with antenna or fiber. When using SC technology, the receiver scans all diversity branches and selects them as output signals before the SNR of the signals drops below the set threshold. When the signal is less than the threshold, the receiver rescans and switches to another branch. Diversity antenna is used to enhance the signal coverage in the area, which can solve the problem of multipath distortion.
- **Wireless connection.** The wireless connection is that the signal received by the terminal can be transmitted to the user through wireless fidelity (Wi-Fi) technology. Nowadays, wireless and mobile devices are used more and more widely. Devices connected to the network using the wireless network technology is also greatly improved. IEEE 802.11 standard is the main standard of wireless local area networks (WLAN), including IEEE 802.11 a/b/g/n, IEEE 802.11 af/ac and IEEE 802.11ax, and so on [156]. The most important indicators to measure the quality of Wi-Fi are delay, jitter and packet loss. When one or more packets cannot reach the destination, the packet loss occurs. It can affect the perceived quality of the application in Wi-Fi networks. Therefore, chooses the appropriate packet loss model is crucial. In this way, communication can be easily realized by mobile phones. In addition, cellular network can be used [18].

### D. CHANNEL SYSTEM IN OPTICAL WIRELESS COMMUNICATIONS

In the process of transmitting information through wireless channels, losses are inevitable. Scattering means that electromagnetic waves interact with atmospheric molecules or aerosols to redistribute incident energy in all directions according to certain rules. It can be divided into three categories [157], [158]:

- **Rayleigh scattering.** It has the following characteristics: (1) Scattered light intensity is inversely proportional to the fourth power of wavelength; (2) The scattered light fluxes of the front half and the back half of the particles are equal; (3) The forward and backward scattered light

is the strongest, twice as strong as the vertical direction; and (4) The forward and backward scattered light have the same polarization state as the incident light; the scattered light in the vertical direction is fully polarized.

- **Mie scattering.** It is that scattering of particles with diameter similar to radiation wavelength, such as aerosol particles, fog rain and haze. It is different from Rayleigh scattering in symmetrical distribution, but scattering is stronger in the forward direction than in the backward direction, with obvious directivity. It has the following characteristics (1) The variation of scattering intensity with wavelength is not as intense as Rayleigh scattering. With the increase of scale parameters, the total scattered energy increases rapidly and finally tends to a certain value in the form of vibration; (2) Scattered light intensity has many maxima and minima with the change of angle. When the scale parameter increases, the extreme value also increases; (3) When the scale parameter increases, the ratio of forward scattering to backward scattering increases, making the particle front hemisphere scattering increase.
- **Non-selective scattering.** It occurs when the radius of the particles (for instance raindrops) is much larger than the wavelength of the OOWC beam. When the atmosphere is filled with large particles of dust, resulting in serious attenuation of the received data. Therefore, this case is not discussed in this paper.

Based on the above three scattering loss, OOWC is vulnerable to the Mie scattering. According to [159], attenuation in the atmospheric can be described by Beer's Law. The expression is as follows:

$$h_{pli} = \exp(-\varphi_i d_i) \quad (1)$$

where  $d_i$  is the distance of the OOWC links, and  $\varphi_i$  represents the attenuation coefficient. The value of  $\varphi_i$  varies with the weather conditions. In the Kim model, the expression for  $\varphi_i$  is as follow [62]:

$$\varphi_i = \frac{3.91}{A_v} \left( \frac{\lambda \times 10^{-10}}{55} \right)^{-f(A_v)} \quad (2)$$

where  $A_v$  is atmospheric visibility in km,  $\lambda$  is wavelength in m,  $f(A_v)$  is a function of  $A_v$  [160]:

$$f(A_v) = \begin{cases} 0, & A_v < 0.5 \text{ km} \\ A_v - 0.5, & 0.5 < A_v < 1 \text{ km} \\ 0.16A_v + 0.34, & 1 < A_v < 6 \text{ km} \\ 1.3, & 6 < A_v < 50 \text{ km} \\ 1.6, & A_v > 50 \text{ km} \end{cases} \quad (3)$$

- **Clouds.** The existence of clouds depends to a great extent on the climate in the region. Multiple scattering effect is very important when light beam passes

through clouds. Scattering includes time and frequency dispersion and depolarization.

- **Fogs.** It is generally believed that visibility is higher than 1000 m in haze or mist, while visibility is lower than 1000 m in fog [157]. Their composition and size distribution vary greatly. According to previous analysis [157], [161], it can be obtained that the fog attenuation becomes more serious with the increasing of wave-length. In order to solve the influence of fog in OOWC link, the method of increasing transmitting power is generally adopted.
- **Rain.** Rain attenuation is due primarily to the scatter-ing phenomenon as in the case of aerosols. In infrared, the wavelength is much smaller than the diameter of the raindrops. The value of the standardized cross section  $Q$  domains equal to 2 whatever the wavelength (geometrical optics field). Scattering attenuation depends of the quantity of raindrops intercepted in the radiation path. In the meantime, the raindrop has a wave-length similar to that of the wireless at higher frequencies, which causes the RF signal to decay.
- **Snow.** Snow attenuation is closely related to humidity (or the snow density) and actual snow rate  $S$  (mm/h). Similar to rain attenuation, it increases with the increase of snow rate.

## V. KEY TECHNOLOGIES FOR RELAY-ASSISTED TECHNOLOGY IN OPTICAL WIRELESS COMMUNICATIONS

Each optical technology has its own unique principles and different ways of RAT. Thus, they may differ in modulation techniques, transmission systems, receiving systems, and communication media. This subsection analyzes the key technologies of RAT in OWC, including relay protocols, channel models, modulation methods, coding scheme, physical layer security.

### A. RELAY-ASSISTED TECHNOLOGY IN INDOOR OPTICAL WIRELESS COMMUNICATIONS

#### 1) PROTOCOLS OF RAT IN IOWC

Adopts the model of subcarrier pairing of AF relay of lamps and lanterns of the PLC signal demodulation, scaling the selected signal subcarrier signal and modulation. In addition, a model of DF relay also decodes signals. Only when decoding is considered to be a success, can based on the external error detection code, DF model relay will return data coding and modulation, and will forward it to the destination [162].

In [163]-[166], there are using DF protocol, and there uses AF protocol in [167]. According to the above discussion, AF protocol is easy to implement and low cost, but it cannot eliminate noise; DF protocol can completely eliminate the influence of noise, but the implementation complexity is high.

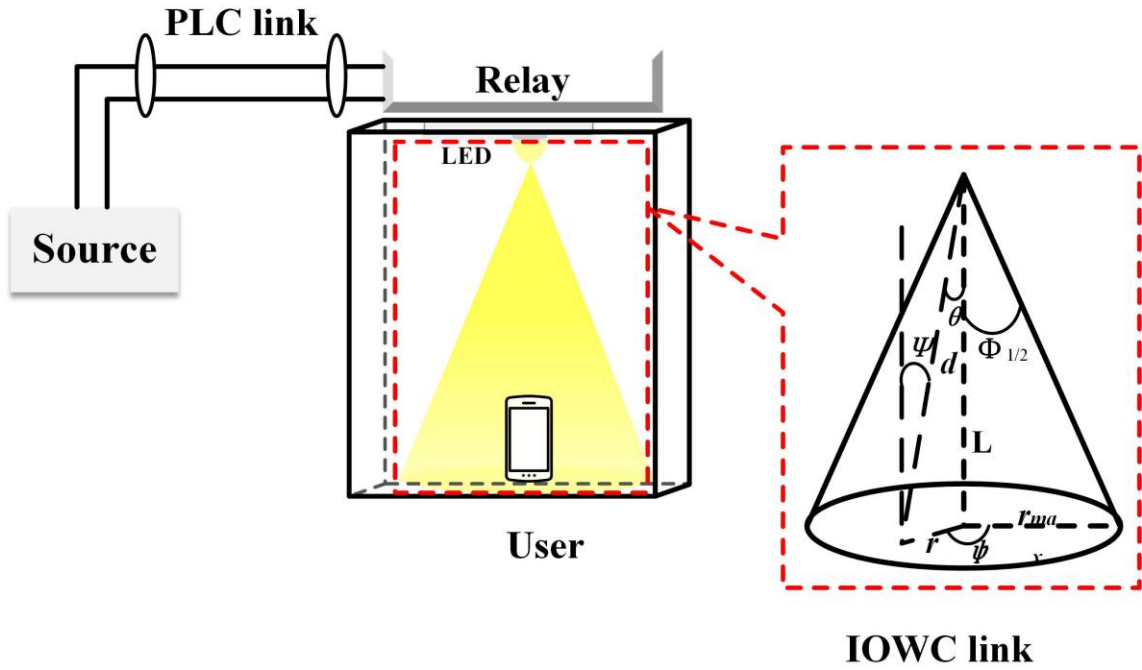

FIGURE 10. System model of the PLC-IOWC system [168].

### 2) CHANNEL MODEL OF RAT IN IOWC

The system model for the hybrid PLC/IOWC system with the use of relay is presented and the overall capacity is formulated. The system model under consideration is shown in Fig. 10 [168]. PLC users can be connected to the network through PLC modems. Supposing the source node on a layer, IOWC users in another layer. Source node through the PLC link to send data to be amplified, and through the IOWC link retransmission to the destination. The complex channel gains  $h_p$  and  $h_v$  represent the source-to-relay channel gain, (for example, the PLC link) and the channel gain of the IOWC link (for instance, the relay-to-destination channel), respectively. Assuming that the two channels are independent, and distribution are the same.

The channel in PLC is as follow [169]-[171]:

$$H(m) = \sum_{t=1}^N \underset{\text{weighting}}{g_t} \underbrace{e^{-(a_0+a_1 m^t)l_t}}_{\text{Attenuation}} \underbrace{e^{-j2\pi m \tau_t}}_{\text{Delay}} \quad (4)$$

Where,  $g_t$  is a weighting factor representing the product of the reflection and transmission factors along the path.

The IOWC channel model can be modeled as below [172]:

$$H(m) = \sum_{t=1}^N \eta_{LOS,t} e^{-j2\pi m \Delta\tau_{LOS,t}} + \frac{\eta_{DIFF}}{1 + j m/m_0} e^{-j2\pi m \Delta\tau_{DIFF}} \quad (5)$$

where  $\eta_{LOS,t}$  and  $\eta_{DIFF}$  are the channel gains for the LOS and diffuse signal, respectively,  $\Delta\tau_{LOS,t}$  and  $\Delta\tau_{DIFF}$  are the corresponding signal delays of LOS and diffuse portions, respectively, and  $m_0$  is the cut-off (3-dB) frequency of the pure diffuse channel.

### 3) MODULATION METHODS OF RAT IN IOWC

The LED visible light communications system generally includes the upper and lower communications links, in which the downlink communications link refers to the signal loaded to the LED drive circuit to directly modulate the light intensity emitted by the LED. Uplink is a communications link from the reverse end to the active end, and uplink and downlink adopt different modulation methods [158]. Orthogonal frequency division multiplexing (OFDM), spread frequency shift keying (S-FSK), phase-shift keying (PSK), and quadrature amplitude modulation (QAM) are examples of applicable modulation schemes used in PLC technology [173]. Generally, In the actual communication system, the relay on one channel may affect the transmission of other channel signals when working. The effective method is to adopt OFDM technology.

- **OFDM modulation.** In order to overcome the inherent characteristics of power lines, such as strong noise, delay dispersion, and multipath fading, OFDM is often regarded as the most suitable modulation technique [91], [169], [174]. A multiply subcarrier distribution scheme is proposed to consider the frequency selectivity of IOWC and PLC channels. This scheme improves the PAPR (Peak to Average Power Ratio) problem caused by the application problem caused by the application of OFDM to LED emitters, and overcomes the interference between different light sources through the cooperation between spatial distributed light sources. At the same time, the robustness of the system against local link occlusion is improved [162]. QAM and OFDM for transmission are adopted in [175]. In [175], there established the PLC and IOWC system



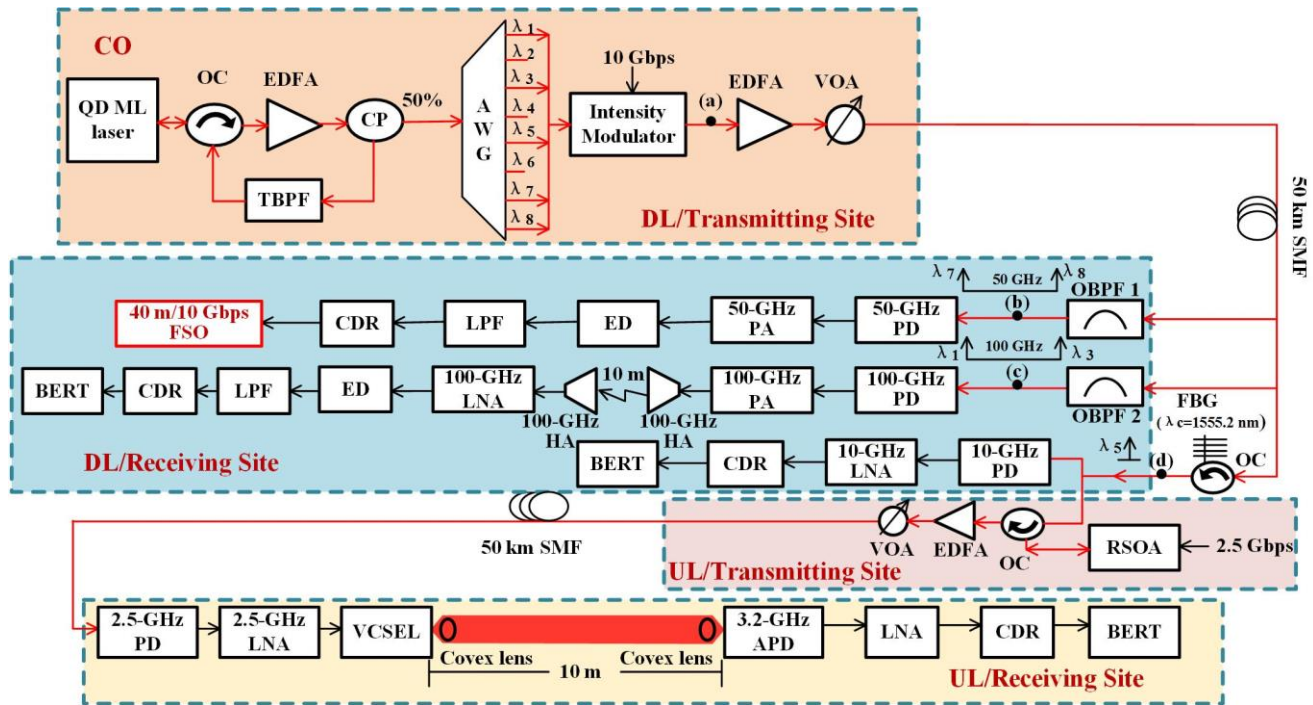

FIGURE 11. Experimental configuration of the proposed bidirectional WDM hybrid fiber-wired/fiber-wireless/fiber-IOWC/fiber-IOWC transmission system based on a self-injection locked quantum dash laser and a reflective semiconductor amplifier [177].

model based on OFDM modulation, and studied four channel estimation methods based on pilot frequency. The results show that the method based on discrete Fourier transform (DFT) can improve the performance of least squares (LS) combined with linear interpolation, while the performance of singular value decomposition is similar to that of interpolation based on discrete Fourier transform. Considering the performance and complexity of the algorithm, singular value decomposition combined with linear interpolation is the best choice of the four methods.

- **Color shift keying (CSK) modulation.** CSK is suitable for high data rate transmission. Compared with other modulation schemes, such as OOK, and pulse position modulation, CSK does not regulate the intensity of the light flux generated, and does not provide inrush flow in large-scale LEDs [172]. It is the first time combining OFDM and CSK for a cascaded PLC-IOWC system in [172].
- **Bit division multiplexing (BDM) modulation.** In order to improve the capacity of multiuser channel and the flexibility of channel resource allocation, BDM was used to realize the multiplexing from symbol level to bit level [169].
- **Wavelength division multiplexing (WDM) technology.** WDM technology refers to the technology that the same optical fiber transmits multiple wavelengths at the same time, like Fig. 11, after the optical signal from the multi-wavelength laser (QD ML laser) is injected through the ring operator and EDFA, it is divided into two optical signals by the 3 dB fiber coupler (CP), one

is transmitted to the array waveguide grating, and the other is transmitted to optical circulator (OC) through the tunable bandpass filter (TBPF) to complete the closed loop. AWG is used to select baseband signals that carry 100 GHz millimeter wave, 50 GHz millimeter wave and 10 Gbps for hybrid transmission. The mixed signal is modulated by intensity, amplified by EDFA, and then processed by a variable optical attenuator and transmitted through a 50 km single-mode fiber link. After that, the mixed WDM signal is separated by a  $1 \times 3$  coupler and selected by two optical bandpass filters (OBPF1 and OBPF2) and a FBG.

The receiving terminal receives an optical signal which is re-modulated by an acousto-optic modulator with an uplink pseudo-random binary sequence signal of 2.5 Gbit/s by a reflective semiconductor optical amplifier. After being amplified by EDFA and adjusted by variable optical attenuator, the signal is transmitted through 50 km single-mode optical fiber link, detected by 2.5 GHz photodiode, amplified by 2.5 GHz low noise amplifier, and sent to multimode system based on vertical cavity surface laser transmitter. After being directly modulated by 2.5 Gb/s data stream, the optical signal is transmitted to 10 m free space through convex lens. The optical signal is received by convex lens and detected on 3.2 GHz silicon-based APD at a response rate of 0.44 mA/mW (680 nm). The received data is then amplified by low noise amplifier, recovered and measured [177]. The combination of FSO and WDM is

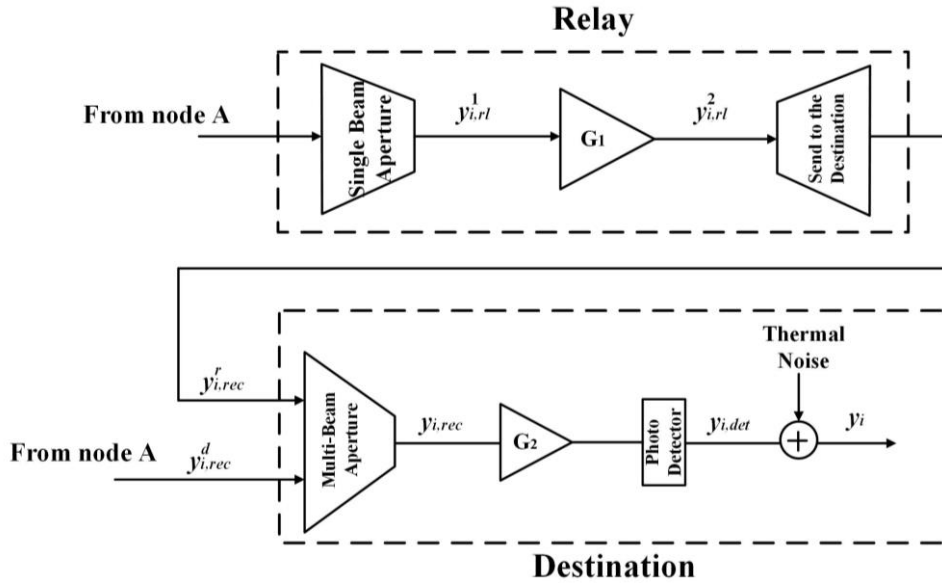

FIGURE 12. Block diagram of the receivers at the relay and the destination with the notations of the signals at different parts of the receivers [178].

a necessary condition for 5G to form complementary advantages [178].

- **Binary pulse position modulation (BPPM).** In [179], this scheme considers BPPM, as shown in Fig. 12. In the destination node, the decision variable of each bit is the number of photoelectrons collected in two corresponding chips. At the output of the receiver,  $y_0$  and  $y_1$  represent the photoelectron numbers in the first and second chips. The detector compares  $y_0$  and  $y_1$ , and if it detects  $y_0 > y_1$ , photoelectron numbers in the first and second chips. The detector compares  $y_0$  and  $y_1$ , and if it detects  $y_0 > y_1$ , it is "0". Otherwise, it is "1".

#### 4) FULL-DUPLEX RAT IN IOWC

Yang *et al.* discussed two cases of full-duplex RAT in IOWC [180], [181]. In the case of three LEDs, there is a time difference between the signal that 3-luminaires, which stand for source, relay and destination. Luminaire 2 receives from luminaire 1 and the signal sent to luminaire 3 in a half-duplex system, which reduces the throughput of the network. So, the full-duplex is a good option. However, in addition to receiving the signal from the source, the relay is also affected by its own signal, which is called self-infection. Since the self-infection signal is known, the signal can be fed back to the relay receiver, and the elimination of the self-infection signal can be realized after the relevant operation.

### B. RELAY-ASSISTED TECHNOLOGY IN OUTDOOR OPTICAL WIRELESS COMMUNICATIONS

#### 1) DIFFERENT PROTOCOLS IN OOWC

In OOWC, the commonly used protocols include two types: AF protocol and DF protocol. The common relaying protocols are AF protocol and DF protocol. The former is simple in operation, but it may amplify the noise in relay

terminal, which might have bad effect to communication quality. For latter, after it received the light signal, and then converted it to electrical signal, next to decoded, eventually re-encoded and forward to the next hop.

#### 2) CHANNEL MODEL OF RAT IN OOWC

For OOWC link, Log-normal distributions, which is widely believed better under weak turbulence, Gamma-Gamma distributions, are generally regarded as optimal model in strong turbulence, Negative Exponential distributions, and Malaga distributions can be selected [72], [73].

- **Log-normal distributions.** The irradiance  $I$  of log-normal distribution in weak turbulence conditions can be expressed following:

$$f_I(I) = \frac{1}{2I\sqrt{2\pi\sigma_x^2}} \exp\left(-\frac{(\ln(I) - 2\mu_x)^2}{8\sigma_x^2}\right) \quad (6)$$

where  $\mu_{x_{ij}}$  and  $\sigma_{x_{ij}}^2$  are the mean and variance of  $X_{ij}$ , and  $X = (1/2)\ln I$ .

- **Gamma-Gamma distributions.** The Gamma-Gamma model suggests that the light intensity scintillation is the result of the combined action of large-scale and small-scale vortices. The SNR  $f_{oowc}(x)$  of OOWC link is as follow [75] and the cumulative distribution function (CDF)  $f_{oowc}(x)$  of OOWC link with Gamma-Gamma distribution can be expressed as [182]:

$$f_{oowc}(x) = \frac{(\alpha\beta)^{2\gamma}}{\Gamma(\alpha)\Gamma(\beta)\left(\frac{x}{g}\right)^{\gamma}} x^{2\gamma-1} \times B_{\alpha-\beta}\left(2\sqrt{\alpha\beta\sqrt{g}}\right) \quad (7)$$

$$F_{OOWC}(x) = \frac{(\alpha\beta)^{2t}}{\Gamma(\alpha)\Gamma(\beta)g^{-t}} x^t \times G_{1,2}^{2,1} \left[ \alpha\beta \sqrt{\frac{x}{g}} \Big|_{-q}^{1-2t} \right] \quad (8)$$

where  $\Gamma(\cdot)$  means gamma function,  $t = (\alpha+\beta) / 4$ ;  $B_{\alpha,\beta}$  is the Bessel functions of the second kind, and  $\alpha - \beta$  is the order,  $g$  refers to the OOWC fading gain,  $G_{1,2}^{2,1}[\cdot]$  is the Meijer's G-function,  $q = (\alpha - \beta) / 2$ ,  $\alpha$  and  $\beta$  are light intensity as number of large-scale and small-scale cyclones, the relationships among  $\alpha$ ,  $\beta$  and Rytov Variance  $\sigma_R^2$  are as follows:

$$\alpha = \left( \exp \left[ \frac{0.49\sigma_R^2}{(1+1.11\sigma_R^{12/5})^{7/6}} \right] - 1 \right)^{-1} \quad (9)$$

$$\beta = \left( \exp \left[ \frac{0.51\sigma_R^2}{(1+0.69\sigma_R^{12/5})^{5/6}} \right] - 1 \right)^{-1} \quad (10)$$

$$\sigma_R^2 = 1.23C_n^2 k^{7/6} L^{11/6} \quad (11)$$

where  $C_n^2$  is the refractive index,  $k = 2\pi/\lambda$  is the wavenumber,  $L$  is the link transmission distance.

For RF link,  $\eta$ - $\mu$  distributions [72], Rayleigh fading [74], Nakagami- $\mathcal{M}$  fading [75], Rician fading [76] and  $\mathcal{M}$  distribution [77] could be selected.

- **$\eta$ - $\mu$  distributions.** Rayleigh ( $\eta \rightarrow 0$ ,  $\kappa \rightarrow 0$ ,  $\mu=1$ ), Rician ( $\mu=1$ ) and Nakagami-m ( $\eta \rightarrow 0$ ,  $\kappa \rightarrow 0$ ,  $\mu=m$ ) distributions [112]. The  $f_{RF}(x)$  of RF link with  $\eta$ - $\mu$  distribution can be expressed as [108]:

$$f_{RF}(x) = \frac{2\sqrt{\pi}h^\mu}{\Gamma(\mu)} \left( \frac{\mu}{\bar{P}_{SRI}} \right)^{\mu+0.5} \left( \frac{P_{SRI}}{H} \right)^{\mu-0.5} \times \exp \left( \frac{-2\mu h p_{SRI}}{\bar{P}_{SRI}} \right) I_{\mu-0.5} \left( \frac{2\mu H p_{SRI}}{\bar{P}_{SRI}} \right) \quad (12)$$

- **Nakagami- $\mathcal{M}$  distribution.** In [113],  $\mu$  and  $m$  are two important parameters of Nakagami- $\mathcal{M}$  distribution. where  $m$  is the average power and  $\mu$  represents the severity of fading. The PDF obeys the following Nakagami- $\mathcal{M}$  distribution:

$$f_\gamma(\gamma) = \frac{m^m \times R^{\mu-1}}{\Gamma(m)\bar{\gamma}^m} \exp\left(-\frac{m\gamma}{\bar{\gamma}}\right) \quad (13)$$

Under Nakagami- $\mathcal{M}$  distribution, the power  $R$  of the signal follows Gamma distribution:

$$P(R) = \frac{\mu \times R^{\mu-1}}{\left( Re^\mu \times \text{Gamma}(\mu) \right) \times \exp\left(-\mu \times \frac{R}{Re}\right)} \quad (14)$$

where  $Re$  is the average power. Under Nakagami-m fading, the average bit error rate (BER) performance curve of various modulation techniques can be expressed as:

$$P(\text{BER}) = G_c \times R^{-M} \quad (15)$$

where  $G_c$  is the coding gain.  $M$  is the slope of average BER curve, also called the diversity gain order.

### 3) CHANNEL MODEL IN SATELLITE

As the OOWC link is seriously affected by clouds, the mixed OOWC/RF link is still dominated by RF link and supplemented by OOWC link. The mixed relay system can also be used in maritime surveillance [183]. Considered to be in the weak turbulence regime for satellite-to-ground optical communication links and the channel distribution in this regime is given by the log-normal distribution expressed as [129]:

$$f_t(I_t) = \frac{1}{I_t \sqrt{2\pi\sigma_R^2}} \exp\left(-\frac{(\ln(I_t) + \sigma_R^2/2)^2}{2\sigma_R^2}\right), I_t > 0 \quad (16)$$

### 4) MODULATION METHODS IN OOWC

The system uses intensity modulation with an OOK control signal and intensity modulation with direct detection (IM/DD) receiver.

- **OOK modulation.** As shown in Fig. 13, the system uses intensity modulation with an OOK control signal and intensity modulation with direct detection (IM/DD) receiver [146]. Detection threshold is adjusted based on atmospheric turbulence intensity; accordingly, it is suitable for areas with varying turbulence intensity [184].
- **Pulse Position Modulation (PPM).** It is another modulation used in OOWC system, which does not need adaptive detection threshold [184].
- **Subcarrier intensity modulation (SIM).** It does not require adaptive detection threshold and compared with PPM has higher spectral efficiency [184].
- **Space-time block coding (STBC),** is one of the techniques used in wireless communication systems. STBC collects various copies of transmitted data with the help of multiple antennas. Correct combination of these copies at the receiver will significantly improve performance of the system. Among various STBCs, Alamouti Coding (AC) is the easiest orthogonal STBC used for MIMO systems and has full diversity and unit code rate [184].

## C. RELAY-ASSISTED TECHNOLOGY IN UNDERWATER WIRELESS OPTICAL COMMUNICATIONS

### 1) DIFFERENT PROTOCOLS IN UOWC

In UOWC, the optical signal received at each hop is converted into an electrical signal, which is then decoded, encoded, and transmitted to the next hop in DF transmission [185]. Although DF greatly improves electrical-to-electrical performance by limiting background noise propagation, it introduces additional power consumption and signal processing delays. In addition, synchronization and clock recovery are additional challenges that need to be addressed

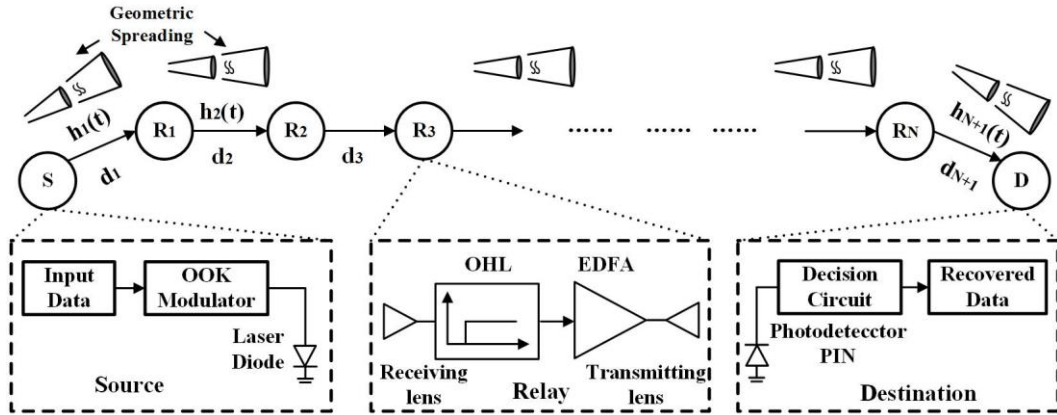

FIGURE 13. OAF relaying OOWC systems using OOK signaling [146].

in Gbps links. In contrast, AF relays perform an optical-to-electrical (OEO) conversion at each node, amplifying the received signal through the current, and then retransmitting the amplified signal for the next hop. The main disadvantage of AF transmission is the propagation of noise at each node, which is amplified and accumulated through the path. As a complement to the expensive OEO conversion, all-optical relay has the advantage of enabling high-speed transmission without the need for OEO conversion and complex optoelectronic equipment.

### 2) CHANNEL MODEL IN UOWC

Considered to be in the weak turbulence regime for satellite-to-ground optical communications links and the channel distribution in this regime is given by the log-normal distribution expressed as [129], [186]:

$$f_{h_{ij}}(h_{ij}) = \frac{1}{2h_{ij}\sqrt{2\pi\sigma_{X_{ij}}^2}} \exp\left(-\frac{(\ln(h_{ij}) - 2\mu_{X_{ij}})^2}{8\sigma_{X_{ij}}^2}\right) \quad (17)$$

where  $\mu_{X_{ij}}$  is the mean of  $X_{ij}$ ,  $\sigma_{X_{ij}}^2$  is the variance, and

$$X_{ij} = (1/2)\ln h_{ij}.$$

### 3) MODULATION METHODS IN UOWC

- **CDMA technology.** Among many access schemes, optical code division multiple Access (OCDMA), as an access technology for asynchronous users without central controller to share resources, has attracted wide attention and has a high application prospect in underwater environment [78]. In relay-assisted point-to-point UOWC systems, the use of relay can significantly improve performance. In the 90 m point-to-point clear link in the ocean, using only the double jump transmission, can make  $10^{-6}$  bit error rate (BER) improve 32 dB [186].
- **OFDM technology.** OFDM technology can be used because of its advantages of high spectrum efficiency and resistance for the presence of instability channel [187].

- **Four-level pulse amplitude modulation (PAM4) technology.** In [188], the 488-nm LD transmitter with light injection and photoelectric feedback technology was first used in PAM4 UOWC system, and a good bit error rate was achieved on the 10 m underwater link.

## D. OTHER RELAY TECHNOLOGIES IN OPTICAL WIRELESS COMMUNICATIONS

### 1) CODING METHODS IN UOWC

There are three types of coding methods: traditional transmission mode, network coding transmission technology and physical layer network coding transmission technology. For the traditional transmission mode, the relay node only stores and forwards the information without any processing. The latter two technologies deal with the information of relay nodes, among which the physical layer network coding transmission mode effectively improves the throughput of communications.

### 2) PHYSICAL LAYER SECURITY IN OWC

The use of MIMO in PLC ensures higher data rates and better coverage than single input single output system, so the application of MIMO technology in indoor OWC can increase the transmission capacity of the system exponentially [29], [189], [190].

RF link is likely to be vulnerable to eavesdropping due to its broadcasting characteristics, while OOWC/OWC link is more secure due to its highly directional beam. Therefore, the physical layer security of RF/OOWC and RF/UOWC hybrid systems is a very important consideration at the moment, as RF hop is vulnerable to attack [191].

Illi *et al.* proposed some systems in [191]-[193]. In addition to considering a new mixed RF/UOWC system, they [191] also consider the security performance of the configuration under consideration, which has multiple antenna AF relays, as well as multiple eavesdropping devices; the dual-hop of secrecy performance mixed RF-UOWC system [192] is examined, they adopt AF relay scheme with fixed gain or variable gain and a dual-hop DF mixed RF/UOWC system can be proposed in [193].

## VI. CHALLENGES AND POTENTIAL SOLUTIONS

It is necessary to consider how to choose the location of relay, which is no barrier. The underwater environment is relatively complex. In addition to the disturbance of rocks and weeds, underwater creatures will also affect the underwater communications.

The relaying protocols including AF protocol and DF protocol used into optical wireless communications. The former is simple in operation, but it may amplify the noise in relay terminal, which might have bad effect to communications quality. For latter, after it received the light signal, and then converted it to electrical signal, next to decoded, eventually re-encoded and forward to the next hop. Thus, DF relaying needs converter, decoder, and encoder with high-speed data to achieve data rates for Gbps [185].

In the proposed PLC-IOWC network open challenge, it may need to consider multiple user subcarrier allocation and power allocation [194]. Due to maldistribution of LED illuminant irradiation intensity, the signal in the area far away from the light source is weak, so non-Lambertian optical source can be considered.

Already on the market have a transfer rate of 10 Gbps (assuming the transmission distance of a few hundred meters) of OOWC link on the ground, and a recent experiment of wireless optical communications system of transmission speed is expected to be higher. In order to further improve the limit of optical communication system and overcome the main technical challenges (especially the atmospheric turbulence decay and bad weather), recently in optical communications system a lot of research on the physical layer design issues. These are primarily witnessed by several exciting developments in the field of RF communications over the past decade or so in the physical layer.

Considering the safety and electromagnetic interference resistance, test the wireless optical communications between the air moving target, namely choose wireless optical communication as a field combat vehicles, ships, or radio, means of communications between the movement state of voice and data transmission. It puts forward high demands on beam target tracking technology. Although some progress has been made in such experiments, but with the requirements of practical application is still a certain distance.

The combination of 3D printing technology and OWC can be the new scheme to reduce the cost. The UAV electro-optical pod is developed by 3D printing technology. The printing material is PLA. Its accuracy is 0.1 mm. The pod is designed in square shape. Solid-state lighting lamps and lanterns of 3D printing not only improves the visual appeal and function, but also makes the prototype production faster, easier to launch new products, reduce the cost of lamps and lanterns.

In addition to we discussed above, OWC communication under RAT can also be combined with frequency division multiplexing, and non-orthogonal multiple access technology,

etc. At the same time, power allocation under RAT is also considered. Beyond that, though, channel models for OOWC and RF links also need to be optimized.

## VII. CONCLUSION

In this survey, the basic knowledge of OWC under relay technologies are discussed, including IOWC, OOWC and UOWC. For these three relay systems, OOWC link is subject to the Gamma-Gamma distribution, and the RF hop is influenced by the Nakagami- $M$  distribution. Meanwhile, according to the advantages of OOWC and RF communications, the application of different scenarios is also proposed. In addition, the all-optical OWC relay system is better to the long-distance communications. The physical methods and techniques, such as MIMO communications, cooperative diversity, new channel coding and adaptive transmission has been exploring in recent OWC literatures, and in our survey provides a detailed description of these research efforts. Accordingly, in order to better solve the problems in OOWC communications, it is significant to verify by simulation experiments. In addition, it is one of future work to research the RAT in the unmanned surface vessel applications.

## REFERENCES

- [1] M. Z. Chowdhury, M. T. Hossan, A. Islam, and Y. M. Jang, "A comparative survey of optical wireless technologies: architectures and applications," *IEEE Access*, vol. 6, pp. 9819-9840, 2018.
- [2] A. S. Hamza, J. S. Deogun, and D. R. Alexander, "Classification framework for free space optical communication links and systems," *IEEE Commun. Surveys Tuts.*, vol. 21, no. 2, pp. 1346-1382, 2019.
- [3] H. Henniger, and O. Wilfert, "An introduction to free-space optical communications," *Radioengineering*, vol. 19, no. 2, pp. 203-212, 2010.
- [4] A. S. Hamza, S. S. Khalifa, H. S. Hamza, and K. Elsayed, "A survey on inter-cell interference coordination techniques in OFDMA-based cellular networks," *IEEE Commun. Surveys Tuts.*, vol. 15, no. 4, pp. 1642-1670, 4th Quart., 2013.
- [5] Y. Xiao, J. Zhang, Z. Gao, and Y. Ji, "Service-oriented DU-CU placement using reinforcement learning in 5G/B5G converged wireless-optical networks," *OSA*, 2020.
- [6] R. Gu, Y. Qu, M. Lian, H. Li, Z. Wang, Y. Zhu., Q. Guo, J. Yang, D. Wang, and Y. Ji, "Flexible optical network enabled proactive cross-layer restructuring for 5G/B5G backhaul network with machine learning engine," *OSA*, 2020.
- [7] Z. Du, C. Wang, Y. Sun, and G. Wu, "Context-aware indoor VLC/RF heterogeneous network selection: reinforcement learning with knowledge transfer," *IEEE Access*, vol. 6, pp. 33275-33284, 2018.
- [8] A. D. Raza, and S. S. Muhammad, "Achievable capacity region of a gaussian optical wireless relay channel," *J. Opt. Commun. Netw.* vol. 7, no. 2, pp. 83-85, Feb. 2015.
- [9] R Li, T. Chen, L. Fan, and A. Dang, "Performance analysis of a multiuser dual-hop amplify-and-forward relay system with FSO/RF links," *J. Opt. Commun. Netw.* vol. 11, no. 7, pp. 362-370, Jul. 2019.
- [10] S. I. Hussain, M. M. Abdallah, and K. A. Qarage, "Hybrid radio-visible light downlink performance in RF sensitive indoor environments," *Proc. IEEE Commun., Control Signal Processing*, Athens, Greece, May 2014, pp. 81-84.
- [11] C. Chen, D. A. Basnayaka, and H. Haas, "Downlink SINR statistics in OFDM-based optical attocell networks with a poisson point process network model." *Proc. IEEE Globecom*, San Diego, CA, USA, May 2015, pp. 1-6.

- [12] W. Guo, Q. Li, H. Yi, and J. Liu, "A parallel transmission MAC protocol in hybrid VLC-RF network," *J. Commun.*, vol. 10, no. 1, 2015, pp. 80–85.
- [13] L. Yin, X. Wu, and H. Haas, "On the performance of non-orthogonal multiple access in visible light communication," Proc. *IEEE Personal, Indoor Mobile Radio Commun. (PIMRC)*, Hong Kong, China, Aug. 2015, pp. 1354–1359.
- [14] F. Xing, H. Yin, X. Ji, and V. C. M. Leung, "Joint relay selection and power allocation for underwater cooperative optical wireless networks," *IEEE Trans. Wireless Commun.*, vol. 19, no. 1, pp. 251–264, Jan. 2020.
- [15] A. Vavoulas, H. G. Sandalidis, and D. Varoutas, "Underwater optical wireless networks: A k-connectivity analysis," *IEEE J. Ocean. Eng.*, vol. 39, no. 4, pp. 801–809, Oct. 2014.
- [16] M. V. Jamali, A. Chizari, and J. A. Salehi, "Performance analysis of multi-hop underwater wireless optical communication systems," *IEEE Photon. Technol. Lett.*, vol. 29, no. 5, pp. 462–465, Mar. 2017.
- [17] A. Celik, N. Saeed, T. Y. Al-Naffouri, and M.-S. Alouini, "Modeling and performance analysis of multihop underwater optical wireless sensor networks," Proc. *IEEE Wireless Commun. Netw. Conf. (WCNC)*, Apr. 2018, pp. 1–6.
- [18] F. Demers, H. Yanikomeroglu, and M. StHilaire, "A survey of opportunities for free space optics in next generation cellular networks," Proc. *9th Commun. Netw. Services Research Conf. (CNSR)*, 2011, pp. 210–216.
- [19] D. K. Borah, A. C. Boucouvalas, S. Hranilovic, and K. Yiannopoulos, "A review of communication-oriented optical wireless systems," *Springer, EURASIP J. Wireless Commun. Netw.*, 2012.
- [20] R. Li, T. Chen, L. Fan, and A. Dang, "Performance analysis of a multiuser dual-hop amplify-and-forward relay system with FSO/RF links," *J. Opt. Commun. Netw.* vol. 11, no. 7, pp. 362–370, Jul. 2019.
- [21] A. M. Salhab, "A new scenario of triple-hop RF/FSO/RF relay network with generalized order user scheduling and power allocation," *Springer, EURASIP J. Wireless Commun. Netw.*, 2016.
- [22] J. Zhang, X. Pan, G. Pan, and Y. Xie, "Secrecy analysis for multi-relaying RF-FSO systems with a multi-aperture destination," *IEEE Photon. J.*, vol. 12, no. 2, Apr. 2020.
- [23] Y. Chi, D. Hsieh, C. Tsai, H. Chen, H. Kuo, and G. Lin, "450-nm GaN laser diode enables high-speed visible light communication with 9-Gbps QAM-OFDM," *Opt. Express*, vol. 23, pp. 13051–13059, 2015.
- [24] Y. Chi, D. Hsieh, C. Lin, H. Chen, C. Huang, J. He, B. Ooi, S. P. DenBaars, S. Nakamura, H. Kuo, and G. Lin, "Phosphorous diffuser diverged blue laser diode for indoor lighting and communication," *Sci Rep*, vol. 5, 18690, Dec. 2015.
- [25] C. Lin, Y. Chi, C. Tsai, H. Wang, and G. Lin, "39-GHz millimeter-wave carrier generation in dual-mode colorless laser diode for OFDM-MMWof transmission," *IEEE J. Selected Topics Quantum Electronics*, vol. 21, no. 6, pp. 609–618, 2015.
- [26] C. Tsai, C. Lin, C. Lin, Y. Chi, and G. Lin, "60-GHz millimeter-wave over fiber with directly modulated dual-mode laser diode," *Sci Rep*, vol. 6, 27919, Jun. 2016.
- [27] J. Ding, C.-L. I, H. Ma, Y. Li, Z. Zhang, P. Xie, X. Guo, and X. Chen "On the characteristics of indoor non lambertian visible light multipath wireless channels," *J. Xinjiang University (Natural Science Edition)*, vol. 37, no. 3, 2020.
- [28] B. Huang, S.-B. Li, J. Ding, and Z. Xu, "Integrating sphere and cuboid channel models for indoor non-line-of-sight visible light communications," Proc. *2nd IEEE Int. Conf. Computer Commun. (ICCC)*, 2016, pp. 2169–2173.
- [29] J. Ding, C.-L. I, X. Chen, and H. Lai, "Asymmetrical emission beams based visible light communication access points design," Proc. *28th Wireless Opt. Commun. Conf. (WOCC)*, 2019, pp. 1–5.
- [30] M. Taheri, N. Ansari, J. Feng, R. Rojas-Cessa, and M. Zhou, "Provisioning internet access using FSO in high-speed rail networks," *IEEE Network*, vol. 31, no. 4, pp. 96–101, Jul. 2017.
- [31] N. Jia, G. Fang, R. Yang, S. Wang, L. Wang, and Z. Peng, "On the performance of mixed triple-hop FSO/RF/VLC relay system," *J. Shanghai Normal University (Natural Sciences)*, vol. 49, no. 1, pp. 62–68, 2020.
- [32] Y. Kaymak, R. R. Cessa, J. Feng, N. Ansari, M. Zhou, and T. Zhang, "A survey on acquisition, tracking, and pointing mechanisms for mobile free-space optical communications," *IEEE Commun. Surveys Tuts*, vol. 20, no. 2, pp. 1104–1123, 2018.
- [33] X. Song, M. Wang, S. Xing, and Z. Zhao, "Progress of orthogonal frequency division multiplexing based on visible light communication," *Las. Optoelect. Progress*, vol. 55, no. 12, 2018.
- [34] K. Jia, and S. Zhang, "Influence of multiuser interference on performances of direct-current-biased optical orthogonal frequency division multiplexing code division multiple access system for visible light communication," *Las. Optoelect. Progress*, vol. 56, no. 11, 2019.
- [35] J. Luo, L. Fan, and H. Li, "Indoor positioning systems based on visible light communication: state of the art," *IEEE Commun. Surveys Tuts.*, vol. 19, no. 4, pp. 2871–2893, 2017.
- [36] A. R. Ndjiongue, H. C. Ferreira, J. Song, F. Yang, and L. Cheng, "Hybrid PLC-VLC channel model and spectral estimation using a nonparametric approach," *Trans. Emerging Telecommun. Technol.*, vol. 28, no. 12, pp. 1–13, 2017.
- [37] S. Mudrievskiy, "Power Line Communications: state of the art in research, development and application," *Aeu Int. J. Electronics Commun.*, vol. 68, no. 7, pp. 575–577, 2014.
- [38] C. Cano, A. Pittolo, D. Malone, L. Lampe, A. M. Tonello, and A. G. Dabak, "State of the art in power line communications: from the applications to the medium," *IEEE J. Sel. Areas Commun.*, vol. 34, no. 7, pp. 1935–1952, Jul. 2016.
- [39] J. Ding, C.-L. I, J. Wang, and X. Chen, "Research and development of smart power grid oriented wireless optical technology," *Las. Optoelect. Prog.*, vol. 57, no. 21, 2020.210003.
- [40] H. Ma, L. Lampe, and S. Hranilovic, "Integration of indoor visible light and power line communication systems," *IEEE 17th Int. Symposium Power Line Commun. Applications*, Johannesburg, 2013, pp. 291–296.
- [41] T. Komine, and M. Nakagawa, "Integrated system of white LED visible-light communication and power-line communication," *IEEE Trans. Consumer Electronics*, vol. 49, no. 1, pp. 71–79, 2002.
- [42] H. Lei, Y. Zhang, K.-H. Park, I. S. Ansari, G. Pan, and M.-S. Alouini, "Performance analysis of dual-hop RF-UWOC systems," *IEEE Photon. J.*, vol. 12, no. 2, pp. 1–15, Apr. 2020.
- [43] J. Chen, Z. Wang, and T. Mao, "Resource management for hybrid RF/VLC V2I wireless communication system," *IEEE Commun. Lett.*, vol. 24, no. 4, pp. 868–871, Apr. 2020.
- [44] J. Chen, and Z. Wang, "Topology control in hybrid VLC/RF vehicular ad-hoc network," *IEEE Trans. Wireless Commun.*, vol. 19, no. 3, pp. 1965–1976, Mar. 2020.
- [45] Z. Cui, P. Yue, and Y. Ji, "Study of cooperative diversity scheme based on visible light communication in VANETs," Proc. *2016 Int. Conf. Computer Inf. Telecommun. Systems (CITS)*, Kunming, 2016, pp. 1–5.
- [46] M. T. Dabiri, and S. M. S. Sadough, "Optimal placement of UAV-assisted free-space optical communication systems with DF relaying," *IEEE Commun. Lett.*, vol. 24, no. 1, pp. 155–158, Jan. 2020.
- [47] Z. Mobini, S. Zokaei, and M. Mohammadi, "Joint power allocation and relay selection strategies for wireless multi-unicast network-coded systems," *Ad Hoc networks*, vol. 29, no. c, pp. 99–116, 2015.
- [48] A. Bletsas, H. Shin, and M. Z. Win, "Cooperative communications with outage-optimal opportunistic relaying," *IEEE Trans. Wireless Commun.*, vol. 6, no. 9, pp. 3450–3460, 2007.
- [49] D. Cao, B. Zheng, B. Ji, Z. Lei, and C. Feng, "A robust distance-based relay selection for message dissemination in vehicular network," *Wireless Networks*, vol. 26, pp. 1755–1771, 2020.
- [50] K. Zhou, J. Gui, N. Xiong, "Improving cellular downlink throughput by multi-hop relay-assisted outband D2D communications," *Eurasip J. Wireless Commun. Networking*, no. 1, pp. 209, 2017.
- [51] Bharati S and Zhuang W H, "cooperative relay broad-casting for safety applications in vehicular networks." *IEEE Trans. Vehicular Technol.*, vol. 65, no. 12, pp. 9542–9553, 2016.

- [52] J. K. Lee, H. J. Noh, J. Lim, "TDMA-based cooperative MAC protocol for multi-hop relaying networks." *IEEE Commun. Lett.*, vol. 18, no. 3, pp. 435-448, 2014.
- [53] Y. Ding, and H. Jafarkhani, "Single and multiple relay selection schemes and their achievable diversity orders," *IEEE Trans. Wireless Commun.*, vol. 8, no. 3, pp. 1414-1423, 2009.
- [54] H. Cui, L. Song, and B. Jiao, "Weighted bidirectional relay selection for outdated channel state information," *IEEE Trans. commun.*, vol. 62, no. 2, pp. 500-509, 2014.
- [55] J. Zhang, L. Deng, X. Li, Y. Zhou, Y. Liang, and Y. Liu, "Novel device-to-device discover scheme based on random back off in LTE-advanced networks," *IEEE Trans. Veh. Technol.*, vol. 99, pp. 1-1, 2017.
- [56] C. Y. Wang, G. Y. Lin, C. C. Chou, C. W. Yeh, and H. Y. Wei, "Device-to-device communication in LTE-advanced system: a strategy-proof resource exchange framework," *IEEE Trans. Veh. Technol.*, vol. 65, no. 12, pp. 10022-10036, 2016.
- [57] J. Jiang, S. Zhang, B. Li, and B. Li, "Maximized cellular traffic offloading via device-to-device content sharing," *IEEE J. Sel. Areas Commun.*, vol. 34, no. 1, pp. 82-91, 2016.
- [58] X. Shen, "Device-to-device communication in 5G cellular networks," *IEEE Network*, vol. 29, no. 2, pp. 2-3, 2015.
- [59] J. Liu, N. Kato, J. Ma, and N. Kadowaki, "Device-to-device communication in LTE-advanced networks: a survey," *IEEE Commun. Surveys Tuts.*, vol. 17, no. 4, pp. 1923-1940, 2017.
- [60] N. Marchenko, and C. Bettstetter, "Cooperative ARQ with relay selection: an analytical framework using semi-Markov processes," *IEEE Trans. Veh. Technol.*, vol. 63, no. 1, pp. 178-190, 2014.
- [61] Y. Wang, and Q. Zhang, "Path outage probability-based VANETs connection model and performance analysis," *Computer Engineering Applications*, vol.50, no. 21, pp. 100-105, 2014.
- [62] E. S. Altubaishi, and K. Alhamawi, "Capacity analysis of hybrid AF multi-hop FSO/RF system under pointing errors and weather effects," *IEEE Photon. Technol. Lett.*, vol. 31, no. 15, pp. 1304-1307, Aug. 2019.
- [63] O. Bouchet, H. Sizun, C. Boisrobert, F. d. Fornel, and P. Favenec, *Free-space optics: propagation. communication*. ISTE Ltd, London W1T 5DX, UK, 2006, pp. 79-80.
- [64] A. S. Hamza, J. S. Deogun, and D. R. Alexander, "Classification framework for free space optical communication links and systems," *IEEE Commun. Surveys Tuts.*, vol. 21, no. 2, pp. 1346-1382, 2019.
- [65] K. Minato, H. Cheng, and Y. Yamao, "Performance of broadcast transmission from multiple vehicles in vehicle-roadside-vehicle relay network," *Commun. Networking*, pp. 675-679, 2011.
- [66] H. Wu, H. Ma, L. Liu, H. Ma, and P. Yuan, "A traffic-camera assisted cache-and-relay routing for live video stream delivery in vehicular ad hoc networks," *Wireless Networks*, vol. 23, pp. 2051-2067, 2017.
- [67] M. R. Bhatnagar, and M. K. Arti, "Performance analysis of hybrid satellite-terrestrial FSO cooperative system", *IEEE Photon. Technol. Lett.*, vol. 25, no. 22, Nov. 2013.
- [68] K. Mori, M. Terada, K. Nakamura, R. Murakami, K. Kaneko, F. Teraoka, D. Yamaguchi, and S. Haruyama, "Fast handover mechanism for high data rate ground-to-train free-space optical communication system," Proc. *2014 IEEE Globecom Workshops (GC Wkshps)*, Austin, TX, 2014, pp. 499-504.
- [69] J. Li, X. Yuan, and M. Wang, "Link performance evaluation for air sed free space optical communications," *Chin. Opt.*, vol. 12, no. 2, pp. 405-412, Apr. 2019.
- [70] L. Zhang, H. Zhao, S. Hou, Z. Zhao, H. Xu, X. Wu, Q. Wu, and R. Zhang, "A survey on 5G millimeter wave communications for UAV-assisted wireless networks," *IEEE Access*, vol. 7, pp. 117460-117504, 2019.
- [71] S. Şahin, and T. Özbilgin, "On the performance of downlink optical communication via relaying in the presence of pointing errors," Proc. *IEEE Wireless Commun. Networking Conf. Workshops (WCNCW)*, Doha, 2016, pp. 12-17.
- [72] J. Zhang, L. Dai, Y. Zhang, and Z. Wang, "Unified performance analysis of radio frequency/free-space optical dual-hop transmission systems," *J. Lightw. Technol.*, vol. 33, no. 11, pp. 2286-2293, Jun. 1, 2015.
- [73] Z. Ghassemlooy, W. Popoola, and S. Rajbhandari, *Optical wireless communications: system and channel modeling with MATLAB*, Taylor Francis Group, 2013.
- [74] W. M. R. Shakir, "Performance analysis of hybrid mmw RF/FSO transmission system," *Springer Wireless Pers. Commun.*, vol. 109, pp. 2199-2211, 2019
- [75] P. V. Trinh, T. C. Thang, and A. T. Pham, "mmwave RF/FSO relaying systems over generalized fading channels with pointing errors," *IEEE Photon. J.*, vol. 9, no. 1, Feb. 2017.
- [76] L. Yang, T. Liu, J. Chan, and M.-S. Alouini, "Physical-layer security for mixed  $\eta$ - $\mu$  and  $M$ -distribution dual-hop RF/FSO systems," *IEEE Commun. Veh. Technol.*, vol. 67, no. 12, pp. 12427-12431, Dec. 2018.
- [77] Z. Zeng, S. Fu, H. Zhang, Y. Dong, and J. Cheng, "A survey of underwater optical wireless communications," *IEEE Commun. Surveys Tuts*, vol. 20, no. 2, pp. 204-238, 2017.
- [78] J. Ding, C.-L. I, and Z. Xu, "Indoor optical wireless channel characteristics with distinct source radiation patterns," *IEEE Photon. J.*, vol. 8, no.1, pp. 1-16, Feb. 2016.
- [79] N. Saeed, A. Celik, T. Y. Al-Naffouri, and M.-S. Alouini, "Underwater optical wireless communications, networking, and localization: a survey," *Elsevier Ad Hoc Networks*, pp. 1-35, Jan. 2019.
- [80] Z. Zeng, S. Fu, H. Zhang, Y. Dong, and J. Cheng, "A survey of underwater optical wireless communications," *IEEE Commun. Surveys Tuts*, vol. 20, no. 2, pp. 204-238, 2017.
- [81] F. Xing, H. Yin, and L. Jing, "Performance characterization of two-way multi-hop underwater networks in turbulent channels [Invited]," *Chin. Opt. Lett.*, vol. 17, no. 10, Oct. 2019.
- [82] N. Saeed, A. Celik, M. Alouini, and T. Y. Al-Naffouri, "Performance analysis of connectivity and localization in multi-hop underwater optical wireless sensor networks," *IEEE Trans. Mobile Computing*, vol. 18, no. 11, pp. 2604-2615, Nov. 2019.
- [83] S. Kenneth, and M.-S. Alouini, *Digital communication over fading channels*. New York, NY, USA: Wiley, 2005.
- [84] W. Ding, F. Yang, H. Yang, J. Wang, X. Wang, X. Zhang, and J. Song, "A hybrid power line and visible light communication system for indoor hospital applications," *Elsevier Comput. Industry*, vol. 68, pp. 170-178, 2015.
- [85] S. E. Alavi, A. S. M. Supa'at, and S. M. Idrus, "Integrated system of visible free space optic with PLC," *IEEE 9th Malaysia Int. Conf. Commun. (MICC)*, Kuala Lumpur, 2009, pp. 271-275.
- [86] A. H. A. El-Malek, M. A. Aboulhassan, A. M. Salhab, and S. A. Zummo, "Performance analysis and power optimization for spectrum-sharing mixed RF/FSO Relay networks with energy harvesting," *IEEE Photonics Journal*, vol. 11, no. 2, pp. 1-17, Apr. 2019.
- [87] M. Torabi, and R. Effatpanahi, "Performance analysis of hybrid RF-FSO systems with amplify-and-forward selection relaying," *Opt. Commun.*, vol.434, pp. 80-90, 2019.
- [88] B. W. Kim, and S. Y. Jung, "Channel capacity of the distributed MIMO relay in visible light communication systems," *IEEE Photon Netw. Commun.*, vol. 34, pp. 298-305, 2017.
- [89] R. C. Kizilirmak, and M. Uysal, "Relay-assisted OFDM transmission for indoor visible light communication," Proc. *2014 IEEE Int. Black Sea Conf. Commun. Networking (BlackSeaCom)*, Odessa, 2014, pp. 11-15.
- [90] O. Narmanlioglu, R. C. Kizilirmak, and M. Uysal, "Relay-assisted OFDM-based visible light communications over multipath channels," Proc. *17th Int. Conf. Transparent Opt. Networks (ICTON)*, Budapest, 2015, pp. 1-4.
- [91] R. C. Kizilirmak, O. Narmanlioglu, and M. Uysal, "Relay-assisted OFDM-based visible light communications," *IEEE Trans. Commun.*, vol. 63, no. 10, pp. 3765-3778, Oct. 2015.
- [92] M. Kashef, A. Torkey, M. Abdallah, N. Al-Dhahir, and K. Qaraqe, "On the achievable rate of a hybrid PLC/VLC/RF communication system," Proc. *IEEE Global Commun. Conf. (GLOBECOM)*, San Diego, CA, 2015, pp. 1-6.
- [93] M. Kashef, M. Abdallah, and N. Al-Dhahir, "Transmit power optimization for a hybrid PLC/VLC/RF communication system," *IEEE Trans. Green Commun. Networking*, vol. 2, no. 1, pp. 234-245, Mar. 2018.

- [94] A. Gupta, N. Sharma, P. Garg, and M.-S. Alouini, "Cascaded FSO-VLC communication system," *IEEE Wireless Commun. Lett.*, vol. 6, no. 6, pp. 810-813, Dec. 2017.
- [95] J. Ding, C.-L. I, R. Xie, C. Zhang, B. Yu, and H. Lai, "Evaluation of outdoor visible light communications links using actual LED street luminaries," *Proc. 13th Chin. Conf. Biometric Recognition (CCBR)*, 2018, pp. 572-579.
- [96] J. Ding, C.-L. I, H. Zhang, X. Chen, B. Yu, and H. Lai, "Cells planning of VLC networks using non-circular symmetric optical beam," *Proc. IEEE Int. Conf. Commun. (ICC)*, Shanghai, China, 2019, pp. 1-6.
- [97] Z. Huang, Z. Wang, M. Huang, W. Li, T. Lin, P. He, and Y. Ji, "Hybrid optical wireless network for future SAGO-integrated communication based on FSO/VLC heterogeneous interconnection," *IEEE Photon. J.*, vol. 9, no. 2, pp. 1-10, Apr. 2017.
- [98] S. Gao, J. Zhang, and H. Yang, "A reference channel model of indoor integrated power line communication and VLC system," *Electric Power Inf. Commun. Technol.*, vol. 40, no. 6, pp. 1062-1066, 2018.
- [99] J. Song, S. Liu, G. Zhou, B. Yu, W. Ding, F. Yang, H. Zhang, X. Zhang, and A. Amara, "A cost-effective approach for ubiquitous broadband access based on hybrid PLC-VLC system," *Proc. IEEE Int. Symp. Circuits Systems (ISCAS)*, 2016.
- [100] M. Chen, Y. Feng, S. You, M. Zhou, Y. Wang, and Z. Wang, "Performance analysis of channel estimation for hybrid PLC&VLC system," *Study Opt. Commun.* vol. 43, no. 1, pp. 3-6, 2017.
- [101] X. Ma, J. Gao, F. Yang, et al. "Integrated power line and visible light communication system compatible with multi-service transmission," *IET Commun.*, vol.11, no. 1, pp. 104-111, 2017.
- [102] T. Rakia, H. Yang, F. Gebali, and M. Alouini, "Optimal design of dual-hop VLC/RF communication system with energy harvesting," *IEEE Commun. Lett.*, vol. 20, no. 10, pp. 1979-1982, Oct. 2016.
- [103] M. I. Petkovic, A. M. Cvetkovic, M. Narandzic, N. D. Chatzidiamantis, D. Vukobratovic, and G. K. Karagiannidis, "Mixed RF-VLC relaying systems for interference-sensitive mobile applications," *IEEE Trans. Veh. Technol.*, 10.1109/TVT. 2020. 3007676.
- [104] M. Kashef, M. Abdallah, N. Al-Dhahir, and K. Qaraq, "On the impact of PLC backhauling in multi-user hybrid VLC/RF communication systems," *Proc. IEEE Global Commun. Conf.*, 2017.
- [105] Y. Sreenivasa Reddy, M. Panda, A. Dubey, A. Kumar, T. Panigrahi, and K. M. Rabie, "Optimisation of indoor hybrid PLC/VLC/RF communication systems," *IET Commun.*, vol. 14, no. 1, pp. 117-126, 2020.
- [106] T. Nawaz, M. Seminara, S. Caputo, L. Mucchi, F. S. Cataliotti, and J. Catani, "IEEE 802.15.7-compliant ultra-low latency relaying VLC system for safety-critical ITS," *IEEE Trans. Veh. Technol.*, vol. 68, no. 12, pp. 12040-12051, Dec. 2019.
- [107] N. Sharma, A. Bansal, and P. Garg, "Relay selection in mixed RF/FSO system over generalized channel fading," *Wiley Trans. Emerging Telecommun. Technol.*, 2015.
- [108] I. S. Ansari, M. Alouini, and F. Yilmaz, "On the performance of hybrid RF and RF/FSO fixed gain dual-hop transmission systems," *2013 Saudi Int. Electronics, Commun. Photon. Conf.*, Fira, 2013, pp. 1-6.
- [109] N. I. Miridakis, M. Matthaiou, and G. K. Karagiannidis, "Multiuser relaying over mixed RF/FSO links," *IEEE Trans. Commun.*, vol. 62, pp. 1634-1645, 2014.
- [110] L. Yang, M. O. Hasna, and X. Gao, "Performance of mixed RF/FSO with variable gain over generalized atmospheric turbulence channels," *IEEE J. Sel. Areas Commun.*, vol. 33, no. 9, pp. 1913-1924, Sept. 2015.
- [111] L. Kong, W. Xu, L. Hanzo, H. Zhang, and C. Zhao, "Performance of a free space optical relay-assisted hybrid RF/FSO system in generalized M-Distributed channels," *IEEE Photon. J.*, vol. 7, no. 5, pp. 1-19, Oct. 2015.
- [112] J. Zhang, L. Dai, Y. Zhang and Z. Wang, "unified performance analysis of mixed radio frequency/free-space optical dual-hop transmission systems," *J. Lightw. Technol.*, vol. 33, no. 11, Jun. 2015.
- [113] S. Anees, and M. R. Bhatnagar, "Performance of an amplify-and-forward dual-hop asymmetric RF-FSO communication system," *J. Opt. Commun. Netw.*, vol. 7, no. 2, pp. 124-135, 2015.
- [114] T. Rakia, H. Yang, F. Gebali, and M. Alouini, "Power adaptation based on truncated channel inversion for hybrid FSO/RF transmission with adaptive combining," *IEEE photon. J.* vol. 7, no. 4, Aug. 2015.
- [115] G. Djordjevic, M. Petkovic, A. Cvetkovic, and G. K. Karagiannidis, "Mixed RF/FSO relaying with outdated channel state information," *IEEE J. Sel. Areas Commun.*, vol. 33, pp. 1935-1948, 2015.
- [116] E. Zedini, H. Soury, and M. Alouini, "On the performance of dual-hop FSO/RF systems," *Proc. Int. Symposium Wireless Commun. Systems (ISWCS)*, Brussels, 2015, pp. 31-35.
- [117] N. Sharma, A. Bansal, and P. Garg, "Relay selection in mixed RF/FSO system over generalized channel fading," *Wiley Trans. Emerging Telecommun. Technol.*, 2015.
- [118] V. Jamali, D. S. Michalopoulos, M. Uysal, and R. Schober, "Link allocation for multiuser systems with hybrid RF/FSO backhaul: delay limited and delay-tolerant designs," *IEEE Trans. Wireless Commun.*, vol. 15, no. 5, pp. 3281-3295, May 2016.
- [119] A. M. Salhab, F. S. Al-Qahtani, R. M. Radaydeh, S. A. Zummo, and H. Alnuweiri, "Power allocation and performance of multiuser mixed RF/FSO relay networks with opportunistic scheduling and outdated channel information," *J. Light. Technol.*, vol. 34, no. 13, pp. 3259-3272, Jul. 2016.
- [120] E. Illi, F. E. Bouanani, and F. Ayoub, "A performance study of a hybrid 5G RF/FSO transmission system," *Proc. Int. Conf. Wireless Networks Mobile Commun. (WINCOM)*, Rabat, 2017, pp. 1-7.
- [121] P. V. Trinh, T. C. Thang, and A. T. Pham, "Mixed mmWave RF/FSO relaying systems over generalized fading channels with pointing errors," *IEEE Photon. J.*, vol. 9, no. 1, pp. 1-14, Feb. 2017.
- [122] J. Zhao, S. Zhao, W. Zhao, and K. Chen, "Performance analysis for mixed FSO/RF Nakagami-m and Exponentiated Weibull dual-hop airborne systems," *Opt. Commun.*, pp. 294-299, 2017.
- [123] M. Najafi, V. Jamali, and R. Schober, "Optimal relay selection for the parallel hybrid RF/FSO relay channel: non-buffer-aided and buffer-aided designs," *IEEE Trans. Commun.*, vol. 65, no. 7, pp. 2794-2810, Jul. 2017.
- [124] N. Cherif, I. Trigui, and S. Affes, "On the performance analysis of mixed multi-aperture FSO/multiuser RF relay systems with interference," *Proc. IEEE 18th International Workshop Signal Processing Advances Wireless Commun. (SPAWC)*, Sapporo, 2017, pp. 1-5.
- [125] M. Torabi, and N. Mohammadi, "Capacity analysis of an AF relaying asymmetric RF-FSO system in a cognitive radio network," *Proc. 2nd West Asian Colloquium Optical Wireless Commun. (WACOWC)*, Tehran, Iran, 2019, pp. 162-166.
- [126] S. A. Hadiwardoyo, C. T. Calafate, J. Cano, Y. Ji, E. Hernandez-Orallo, and P. Manzoni, "Evaluating UAV-to-car communications performance: from testbed to simulation experiments," *IEEE Annu. Consumer Commun. Networking Conf. IEEE*, 2019, pp. 1-6.
- [127] S. Zhang, H. Zhang, Q. He, K. Bian, and L. Song, "Joint trajectory and power optimization for UAV relay networks," *IEEE Commun. Lett.*, vol. 22, no. 1, pp. 161-164, Jan. 2018.
- [128] M. K. Simon, and M.-S. Alouini, *Digital communication over fading channels: a unified approach to Performance analysis*. Wiley, 2000.
- [129] S. K. Khan, M. Farasat, U. Naseem, and F. Ali, "Performance evaluation of next-generation wireless (5G) UAV relay," *Springer Wireless Personal Commun.* vol. 113, pp. 945-960, 2020.
- [130] K. Dautov, S. Arzykulov, G. N. Refik, and C. Kizilirmak, "On the Performance of UAV-enabled Multihop V2V FSO systems over generalized  $\alpha$ - $\mu$  channels," *Second Int. Conf. Computing Network Commun. (CoCoNet'18)*, 2018, pp:69-73.
- [131] W. Fawaz, "Effect of non-cooperative vehicles on path connectivity in vehicular networks: a theoretical analysis and UAV-based remedy," *Veh. Commun.*, vol.11, pp.12-19, 2018.
- [132] Y. Zeng, R. Zhang, and T. J. Lim, "Throughput maximization for UAV-enabled mobile relaying systems," *IEEE Trans. Commun.*, vol. 64, no. 12, pp:44983-44996, Dec. 2016.
- [133] J. B. Rosolem, R. S. Penze, C. Floridaia, D. C. Dini, and J. E. F. Valadares, "FSO applied to optical fiber sensing: a field test



- demonstration,” *SBMO/IEEE MTT-S Int. Microwave Optoelect. Conf. (IMOC)*, 2017.
- [134] J. B. Rosolem, F. R. Bassan, R. S. Penze, A. A. Leonardi, J. P. Vicentini Fracarolli, and C. Floridaia, “Optical sensing in high voltage transmission lines using power over fiber and free space optics,” *Opt. Fiber Technol.*, vol. 26, pp. 180-183, 2015.
- [135] C. Floridaia, J. B. Rosolem, A. A. Leonardi, C. A. Hortencio, R. F. Fonseca, R. O. C. Moreira, G. C. L. Souza, A. L. Melo, and C. A. M. Nascimento, “Temperature sensing in high voltage transmission lines using fiber Bragg grating and free-space-optics,” *Proc. SPIE Defense, Security, Sensing*, 2013.
- [136] N. Saeed, A. Celik, T. Y. Al-Naffouri, and M.-S. Alouini, “Underwater optical wireless communications, networking, and localization: a survey,” *Ad Hoc Networks*, pp. 1-35, Jun. 2019.
- [137] Y. Li, S. Wang, C. Jin, Y. Zhang, and T. Jiang, “A survey of underwater magnetic induction communications: fundamental issues, recent advances, and challenges,” *IEEE Commun. Surveys Tuts.*, vol. 21, no. 3, pp. 2466-2487, 2019.
- [138] H. Kaushal, and G. Kaddouf, “Underwater optical wireless communication,” *IEEE Access*, vol. 4, pp.1518-1547, 2016.
- [139] C. Shen, Y. Guo, H. M. Oubei, T. K. Ng, G. Liu, K. Park, K.-T. Ho, M.-S. Alouini, and B. S. Ooi, “20-meter underwater wireless optical communication link with 1.5 Gbps data rate,” *Opt. Exp.*, vol. 24, No. 22, Oct. 2016.
- [140] L. Arienzo, “Green RF/FSO communications in cognitive relay-based space information networks for maritime surveillance,” *IEEE Trans. Cogn. Commun. Netw.*, vol. 5, no. 4, pp. 1182-1193, 2019.
- [141] C. Christopoulou, H. G. Sandalidis, and I. S. Ansari, “Outage probability of a multisensor mixed UOWC-FSO setup,” *IEEE Sensors, Lett.*, vol. 3, no. 8, Aug. 2019.
- [142] J. Xu, “Underwater wireless optical communication: why, what, and how? [Invited],” *Chin. Opt. Lett.*, Oct. 2019.
- [143] M. V. Jamali, A. Chizari, and J. A. Salehi, “Performance analysis of multi-hop underwater wireless optical communication Systems,” *IEEE Photon. Technol. Lett.*, vol. 29, no. 5, pp. 462-465, Mar., 2017.
- [144] S. M. Nlom, K. Ouahada, A. R. Ndjiongue, and H. C. Ferreira, “Evaluation of the SFSK-OOK integrated PLC-VLC system under the influence of sunlight,” *Proc. Int. Symp. Networks, Computers Commun. (ISNCC)*, IEEE, 2017.
- [145] X. Huang, X. Xie, J. Song, T. Duan, H. Hu, X. Xu, and Y. Su, “Performance comparison of all-optical amplify-and-forward relaying FSO communication systems with OOK and DPSK modulations,” *IEEE Photon. J.*, vol.10, no. 4, Aug. 2018.
- [146] P. V. Trinh, N. T. Dang, and A. T. Pham, “All-optical relaying FSO systems using EDFA combined with optical hard-limiter over atmospheric turbulence channels,” *J. Lightw. Technol.*, vol. 33, no. 19, pp. 4132-4144, 1 Oct.1, 2015.
- [147] J.-Y. Wang, J.-B. Wang, M. Chen, and X. Song, “Performance analysis for free-space optical communications using parallel all-optical relays over composite channels,” *IET Commun.*, vol. 8, no. 9, pp. 1437-1446, 2014.
- [148] Z. Mostaani, and M. Uysal, “Gamma-Gamma türbülans kanallarında tüm-optik rüdelemeli FSO sistemlerii qn rüde se qimi relay selection in FSO systems with all-optical relaying over gamma-gamma turbulence channels,” *Proc. IEEE 22nd Signal Processing Commun. Applications Conf. (SIU)*, 2014, pp. 710-713.
- [149] P. Puri, P. Garg, and M. Aggarwal, “Multiple user pair scheduling in TWR assisted FSO systems,” *J. Opt. Commun. Netw.* vol. 8, no. 5, May 2016.
- [150] P. Xiao, L. Wang, J. Chuan, X. Wang, J. Kuang, and A. Fei, “Implementation for UAVs Aided Edge Sensing System in Wireless Emergency Communications,” *Proc. 11th Int. Conf. Wireless Commun. Signal Processing (WCSP)*, Xi’an, China, 2019, pp. 1-5.
- [151] C. H. Liu, Z. Chen, J. Tang, J. Xu, and C. Piao, “Energy-Efficient UAV Control for Effective and Fair Communication Coverage: A Deep Reinforcement Learning Approach,” *IEEE J. Selected Areas Commun.*, vol. 36, no. 9, pp. 2059-2070, Sept. 2018.
- [152] J. Ding, C.-L. I, R. Xie, H. Lai, and C. Zhang, “Actual radiation patterns-oriented non-deterministic optical wireless channel characterization,” *Proc. 13th Chin. Conf. Biometric Recognition (CCBR)*, 2018, pp. 517-527.
- [153] M. A. Khalighi, and M. Uysal, “Survey on free space optical communication: a communication theory perspective,” *IEEE Commun. Surveys Tuts.*, vol. 16, no. 4, pp. 2231-2258, 2014.
- [154] J. M. Kahn, and J. R. Barry, “Wireless infrared communications,” *Proc. IEEE*, vol. 85, no. 2, Feb. 1997, pp. 265-298.
- [155] A. S. Hamza, J. S. Deogun, and D. R. Alexander, “Wireless communications in data centers: a survey,” *IEEE Commun. Surveys Tuts*, vol. 18, no. 3, pp. 1572-1595, 2016.
- [156] C. A. G. D. Silva, and C. M. Pedroso, “MAC-layer packet loss models for Wi-Fi networks: a survey,” *IEEE Access*, vol. 7, pp. 180512-180531, 2019.
- [157] O. Bouchet, H. Sizun, C. Boisrobert, F. d. Fornel, and P. Favennec, *Free-space optics: propagation and communication*. ISTE Ltd, London W1T 5DX, UK, 2006, pp. 79-80.
- [158] M. Alzenad, M. Z. Shakir, H. Yanikomeroglu, and M. S. Alouini, “FSO-based vertical backhaul/fronthaul framework for 5G+ wireless networks,” *IEEE Commun. Mag.*, vol.56, no.1, pp. 218-224, Jan. 2018.
- [159] M. T. Dabiri, S. M. Ibraheem, M. Zafrullah, and A. Awan, “Performance analysis of hybrid FSO systems using FSO/RF-FSO link adaptation,” *IEEE Photon. J.*, vol. 10, no. 3, Jun. 2018.
- [160] M. A. Esmail, H. Fathallah, and M.-S. Alouini, “Outdoor FSO communication under fog: attenuation modeling and performance evaluation,” *IEEE Photon. J.*, vol. 8, no. 4, Aug. 2016.
- [161] K. Wang, B. Liu, L. Zhang, Q. Zhang, Q. Tian, and X. Xin, “Review of coded modulation free space optical communication System,” *China Commun.*, vol.12, no.11, pp. 62-78, Nov. 2015.
- [162] H. Ma, L. Lampe, and S. Hranilovic, “Hybrid visible light and power line communication for indoor multiuser downlink,” *J. Opt. Commun. Networking*, vol. 9, no. 8, pp. 635-647, 2017.
- [163] W. Gheth, K. M. Rabie, B. Adebisi, M. Ijaz, and G. Harris, “Performance analysis of integrated power-line/visible-light communication systems with AF relaying,” *IEEE Global Commun. Conf. (GLOBECOM)*, Abu Dhabi, United Arab Emirates, 2018, pp. 1-6.
- [164] M. Jani, P. Garg, and A. Gupta, “Modeling and outage analysis of DF relay assisted mixed PLC-VLC system,” *Proc. IEEE 2018 Twenty Fourth National Conf. Commun. (NCC)*, 2018.
- [165] M. Jani, P. Garg, and A. Gupta, “Performance analysis of a co-operative PLC/VLC system with multiple access points for indoor broadcasting,” *AEU-International J. Electronics Commun.*, vol. 103, no. 12, pp. 64-73, 2019.
- [166] M. Jani, P. Garg, and A. Gupta, “Outage analysis of an asymmetric dual hop PLC-VLC system for indoor broadcasting,” *Proc. IEEE 2019 National Conf. Commun. (NCC)*, 2019.
- [167] W. Gheth, K. M. Rabie, B. Adebisi, M. Ijaz, and G. Harris, “On the performance of DF-based power-line/visible-light communication systems,” *Int. Conf. Signal Processing Inf. Security (ICSPIS)*, DUBAI, United Arab Emirates, 2018, pp. 1-4.
- [168] M. Jani, P. Garg, and A. Gupta, “On the performance of a cooperative PLC-VLC indoor broadcasting system consisting of mobile user nodes for IoT networks,” *IEEE Trans. Broadcasting*, 2020.
- [169] J. Gao, F. Yang, and W. Ding, “Novel integrated power line and visible light communication system with bit division multiplexing,” *Int. Wireless Commun. Mobile Computing Conf. (IWCMC)*, Dubrovnik, 2015, pp. 680-684.
- [170] J. Song, W. Ding, F. Yang, H. Yang, J. Wang, X. Wang, and X. Zhang, “Indoor hospital communication systems: an integrated solution based on power line and visible light communication,” *IEEE Faible Tension Faible Consommation*, Monaco, 2014, pp. 1-6.
- [171] S. M. Nlom, A. R. Ndjiongue, and K. Ouahada, “Cascaded PLC-VLC channel: an indoor measurements campaign,” *IEEE Access*, vol. 6, pp. 25230-25239, 2018.
- [172] A. Ndjiongue, T. Shongwe, H. C. Ferreira, T. M. N. Ngatched, and A. J. H. Vinck, “Cascaded PLC-VLC channel using OFDM and CSK techniques,” *IEEE Global Commun. Conf. (GLOBECOM)*, San Diego, CA, 2015, pp. 1-6.
- [173] A. R. Ndjiongue, H. C. Ferreira and T. Shongwe, “Inter-building PLC-VLC integration based on PSK and CSK techniques,” *Int. Symp. Power Line Commun. Applications (ISPLC)*, Bottrop, 2016, pp. 31-36.

- [174] T. Komine, S. Haruyama, and M. Nakagawa, "Performance evaluation of narrowband OFDM on integrated system of power line communication and visible light wireless communication," *IEEE Symp. Wireless Pervasive Comput.*, Pisa, Italy, Mar. 2006, pp. 6–10.
- [175] L. Yang, J. Li, and J. Zhang, "Hybrid visible light communications (VLC) and PLC system," *Opto-Electronics Commun. Conf. (OECC) Photon. Global Conf. (PGC)*, Singapore, 2017, pp. 1–2.
- [176] M. Chen, S. You, Y. Wang, Z. Wang, and J. Chen, "Performance analysis of pilot-based OFDM channel estimation for hybrid PLC&VLC system," *Proc. 15th Int. Conf. Opt. Commun. Networks (ICOON)*, 2016.
- [177] M. G. Chandra, M. Rahul, D. Binoy, and P. A. Sekhar, "A full-duplex WDM hybrid fiber-wired/fiber-wireless/fiber-VLC/fiber-IVLC transmission system based on a self-injection locked quantum dash laser and a RSOA," *Opt. Commun.*, vol. 427, pp. 202–208, 2018.
- [178] Z. Zhao, Z. Zhang, J. Tan, Y. Liu, and J. Liu, "200 Gb/s FSO WDM communication system empowered by multi-wavelength directly modulated TOSA for 5G wireless networks," *IEEE Photon. J.* vol. 10, no. 4, pp. 1–8.
- [179] M. Karimi, and M. Nasiri-Kenari, "Free space optical communications via optical amplify-and-forward relaying," *J. Lightw. Technol.*, vol. 29, no. 2, pp. 242–248, Jan. 15, 2011.
- [180] H. Yang, and A. Pandharipande, "Full-duplex relay VLC in LED lighting linear system topology," *IECON 2013 39th Annual Conf. IEEE Industrial Electronics Society*, Vienna, 2013, pp. 6075–6080.
- [181] H. Yang, and A. Pandharipande, "Full-duplex relay VLC in LED lighting triangular system topology," *2014 6th Int. Symp. Commun., Control Signal Processing (ISCCSP)*, Athens, 2014, pp. 85–88.
- [182] S. Kazemlou, S. Hranilovic, and S. Kumar, "All-optical multihop free-space optical communication systems," *J. Lightw. Technol.*, vol. 29, no. 18, pp. 2663–2669, 2011.
- [183] Y. Ai, A. Mathur, M. Cheffena, M. R. Bhatnagar, and H. Lei, "Physical layer security of hybrid satellite-FSO," *IEEE Photo. J.*, vol. 11, no. 1, Feb. 2019.
- [184] M. R. Bhatnagar, and S. Anees, "On the performance of alamouti scheme in gamma-gamma FSO links with errors pointing fading," *IEEE Wireless Commun. Lett.*, vol. 4, no. 1, 2015.
- [185] A. Celik, N. Saeed, B. Shihada, T. Y. Al-Naffouri, and M.-S. Alouini, "End-to-end performance analysis of underwater optical wireless relaying and routing techniques under location uncertainty," *IEEE Trans. Wireless Commun.*, vol. 19, no. 2, Feb. 2020.
- [186] M. V. Jamali, F. Akhoundi, and J. A. Salehi, "Performance characterization of relay-assisted wireless optical CDMA networks in turbulent underwater channel," *IEEE Trans. Wireless Commun.*, vol. 15, no. 6, pp. 4104–4116, Jun. 2016.
- [187] Y. Chen, M. Kong, T. Ali, J. Wang, R. Sarwar, J. Han, C. Guo, B. Sun, N. Deng, and J. Xu, "26 m/5.5 Gbps air-water optical wireless communication based on an OFDM-modulated 520-nm laser diode," *Opt. Exp.*, vol. 25, no. 13, pp. 14760–14765, 2017.
- [188] C. Y. Li, H. H. Lu, W. S. Tsai, M. T. Cheng, C. M. Ho, Y. C. Wang, Z. Y. Yang, and D. Y. Chen, "16 Gb/s PAM4 UWOC system based on 488-nm LD with light injection and optoelectronic feedback techniques," *Opt. Exp.*, vol. 25, no. 10, pp. 11598–11605, 2017.
- [189] D. Rende, A. Nayagam, K. Afkhamie, L. Yonge, and P. Bisaglia, "Noise correlation and its effect on capacity of inhome MIMO power line channels," *Proc. IEEE Int. Symp. Power Line Commun. Applications (ISPLC)*, 2011.
- [190] R. Hashmat, P. Pagani, A. Zeddami, and T. Chonavel, "MIMO communications for inhome PLC networks: measurements and results up to 100 MHz," *Proc. IEEE Int. Symp. Power Line Commun. Applications (ISPLC)*, 2010.
- [191] E. Illi, F. E. Bouanani, D. B. D. Costa, F. Ayoub, and U. S. Dias, "On the secrecy performance of mixed RF/UOW communication system," *IEEE Globecom Workshops (GC Wkshps)*, Abu Dhabi, United Arab Emirates, 2018, pp. 1–6.
- [192] E. Illi, F. E. Bouanani, D. B. D. Costa, F. Ayoub, and U. S. Dias, "Dual-hop mixed RF-UOW communication system: a PHY security analysis," *IEEE Access*, vol. 6, pp. 55345–55360, 2018.
- [193] E. Illi, F. E. Bouanani, D. B. D. Costa, P. C. Sofotasios, and S. Muhaidat, "On the physical layer security of a regenerative

relay-based mixed RF/UOWC," *Proc. Int. Conf. Advanced Commun. Technol. Networking (CommNet)*, Rabat, Morocco, 2019, pp. 1–7.

- [194] S. Feng, T. Bai, and L. Hanzo, "Joint power allocation for the multi-user NOMA-downlink in a power-line-fed VLC network," *IEEE Trans. Veh. Technol.*, vol. 68, no. 5, pp. 5185–5190, 2019.



**WENWEN LIU** received the B.S. degree in Electronic information engineering from Shenyang Institute of Engineering, Shenyang, in 2017. She is a graduate student in Xinjiang University. Her research interest includes the free space optical communication and optical wireless relay communication. She is the student memberships of IEEE, China Computer Federation, Chinese Optical Society and Chinese Institute of Electronics.



**JUPENG DING** is currently an Associate Professor in Key Laboratory of Signal Detection and Processing in Xinjiang Uygur Autonomous Region, School of Information Science and Engineering, Xinjiang University, Urumqi Xinjiang, China. He received the Ph. D. degree from the communication engineering, Beijing University of Posts and Telecommunications (BUPT), Beijing, China. In 2013, he joined Key Laboratory of Wireless-Optical Communications, Chinese Academy of Sciences, Optical Wireless Communication and Network Center, School of Information Science and Technology, University of Science and Technology of China, Hefei, China. In 2017, he worked in one world top 500 enterprises. Then he joined Xinjiang University working on optical wireless communication. His current research interests include visible light communication, 5G mobile communication and free space optics. He works as one active reviewer of high level journals including IEEE Communications Letters, IEEE Wireless Communications Letters, IEEE Journal of Lightwave Technology, Elsevier Optics Communications, OSA Optics Letters, and OSA Optics Express. He is senior member of China Institute of Communications, Chinese Optical Society, and Chinese Institute of Electronics.



**JIONG ZHENG** was born in Xinjiang, China in 1977. She received a M.S. degree from Chengdu University of Technology in 2002. She is an associate professor in the school of information science and engineering of Xinjiang University. Her research interests include software engineering and database application. She has presided over the projects of the Education Department of Xinjiang Uygur Autonomous Region, a number of school enterprise cooperation research project, the cooperative education project of the Ministry of education of the people's Republic of China in 2019, the undergraduate education and teaching reform project of colleges and universities in the autonomous region in 2019, and she was awarded the title of teaching expert of the autonomous region in 2015.



**XIFENG CHEN** received the B.S. degree from the Applied Science College of Jiangxi University of Science and Technology, Ganzhou, China. He is a graduate student in Xinjiang University. His current research interests include optical communications for trains, visible optical communication and 5G mobile communication. He is the student memberships of IEEE, China Institute of Communications, Chinese Optical Society, Chinese Institute of Electronics and China computer Federation.



**CHIH-LIN I** is CMCC Chief Scientist of Wireless Technologies. She received a Ph.D. in electrical engineering from Stanford University. She has won the IEEE ComSoc Stephen Rice Prize, Fred W. Ellersick Prize, and 2015 Industrial Innovation Award. She is the Chair of FuTURE 5G SIG, the Chair of WAIA Executive Committee, the Chair of O-RAN TSC, an Executive Board Member of GreenTouch, a Network Operator Council Founding Member of ETSI NFV, a Steering Board Member and Vice Chair of WWRF, a Steering Committee member and the Publication Chair of the IEEE 5G Initiative, a member of IEEE ComSoc SDB, SPC, and CSCN-SC, and a Scientific Advisory Board Member of Singapore NRF. Her current research interests center around “From Green & Soft to Open & Smart.”