

Date of publication xxxx 00, 0000, date of current version xxxx 00, 0000.

Digital Object Identifier 10.1109/ACCESS.2017.DOI

URLLC for 5G and Beyond: Requirements, Enabling Incumbent Technologies and Network Intelligence

RASHID ALI^{1, +}, (Member, IEEE), YOUSAF BIN ZIKRIA^{2, +}, (Senior Member, IEEE),
ALI KASHIF BASHIR³, (Senior Member, IEEE), SAHIL GARG⁴, (Member, IEEE) HYUNG
SEOK KIM^{1, *}, (Member, IEEE)

¹School of Intelligent Mechatronics Engineering, Sejong University, Seoul, 05006, Republic of Korea (e-mails: rashidali@sejong.ac.kr, hyungkim@sejong.edu)

²Department of Information and Communication Engineering, Yeungnam University, Gyeongsan 38541, Korea (e-mail: yousafbinzikria@ynu.ac.kr)

³Department of Computing and Mathematics, Manchester Metropolitan University, Manchester, United Kingdom (e-mail: dr.alikashif.b@ieec.org)

⁴Electrical Engineering Department, École de technologie supérieure, Montreal, Canada (e-mail: sahil.garg@ieec.org)

Corresponding author: H. S. Kim (e-mail: hyungkim@sejong.edu).

This work was supported by the National Research Foundation of Korea (NRF) grant funded by the Korea government (MSIT) (No.2019R1A4A1023746, No. 2019R1F1A1060799)

ABSTRACT The tactile internet (TI) is believed to be the prospective advancement of the internet of things (IoT), comprising human-to-machine and machine-to-machine communication. TI focuses on enabling real-time interactive techniques with a portfolio of engineering, social, and commercial use cases. For this purpose, the prospective 5th generation (5G) technology focuses on achieving ultra-reliable low latency communication (URLLC) services. TI applications require an extraordinary degree of reliability and latency. The 3rd generation partnership project (3GPP) defines that URLLC is expected to provide 99.99% reliability of a single transmission of 32 bytes packet with a latency of less than one millisecond. 3GPP proposes to include an adjustable orthogonal frequency division multiplexing (OFDM) technique, called 5G new radio (5G NR), as a new radio access technology (RAT). Whereas, with the emergence of a novel physical layer RAT, the need for the design for prospective next-generation technologies arises, especially with the focus of network intelligence. In such situations, machine learning (ML) techniques are expected to be essential to assist in designing intelligent network resource allocation protocols for 5G NR URLLC requirements. Therefore, in this survey, we present a possibility to use the federated reinforcement learning (FRL) technique, which is one of the ML techniques, for 5G NR URLLC requirements and summarizes the corresponding achievements for URLLC. We provide a comprehensive discussion of MAC layer channel access mechanisms that enable URLLC in 5G NR for TI. Besides, we identify seven very critical future use cases of FRL as potential enablers for URLLC in 5G NR.

INDEX TERMS 5G, New Radio, MAC Protocol, Tactile Internet, URLLC, Federated Reinforcement Learning.

I. INTRODUCTION

RECENTLY, tactile internet (TI) emerged as a novel technology to move Internet from the Internet of Things (IoT) to real-time interactive techniques with a portfolio of engineering, social and commercial use cases, which will revolutionize most aspects of the future communication technologies [1], [2]. Critical research exertion from academic as well as industrial affiliations has been committed to the research of TI [3]. These studies are generally provoked by the various use cases of TI, such as robotics for health-care, autonomous driving vehicles, and augmented reality

(AR). Conclusively, these human-to-machine (H2M) and machine-to-machine (M2M) communication systems require the response time to be as fastest as it can, which is in few milliseconds (*ms*). For example, haptic control of a robotic arm/actuator is carried out under 10 *ms*. Similarly, multimedia (audio/video) communication requires a latency of up to 100 *ms* [4]. Accordingly, we see that the TI will characterize next-generation of H2M collaboration where the communication technologies give a physiological latency of human beings to bring up real-time intuitive systems. Several research works have highlighted various potential

applications of TI [5]–[9].

One of the key services of 5th Generation (5G) networks is to empower the ultra-reliable and low latency communications (URLLC) capacity, which is required to help exceptional degrees of high reliability and low latency end-to-end (E2E) communication. The 3rd generation partnership project (3GPP) characterizes the basic URLLC reliability essentials for a single data frame of 32 as 99.9%, and an E2E latency of < 1 ms [10]. It is certain that these URLLC requirements of 5G will offer rising to different potential and energizing applications. To enable URLLC services, 3GPP has indicated several features for the 5G New Radio (NR) as a novel radio access technology (RAT) [11], [12], which can be assembled into increased reliability and reduced latency features [13]. 5G NR depends on a flexible orthogonal frequency-division multiple access (OFDM) waveform, such as long-term evolution (LTE) technology. However, in contrary to LTE, 5G NR offers adaptable numerology, with the aim to utilize different sub-carrier spacing for the signal generation, prompting various lengths of the OFDMA symbols [14]. Subsequently, by expanding the OFDM subcarrier spacing from 15 kHz to 120 kHz, a transmission slot of 14 symbols can be decreased from 1 ms to 125 μ s duration. Besides, mini-slots have been introduced, which permits URLLC traffic to utilize considerably shorter time slots [11]. Figure 1 shows a typical TI operation, in which major components and functional requirements at various stages are highlighted. In the figure, tactile core (TC) is the stage of TI where communication of the information takes place, while the rest of the stages are related to the collection/feedback of data from/to the environment/humans/robots.

In this paper, we provide a comprehensive survey on the enabling technologies for 5G NR from URLLC perspectives, covering the role of federated reinforcement learning (FRL), one of the machine learning (ML) techniques, for the intelligent network at the MAC layer resource allocation (MAC-RA) [15] in wireless communication systems. Utilizing the FRL technique as part of 5G NR URLLC requirement has not been given much attention in the past. For more readability, the acronyms and abbreviations used in this survey, along with their definitions, are provided in Table I.

A. URLLC CONCEPT FOR TACTILE INTERNET

TI aims to support physiological interaction between the real-world (human or environment) and virtual-world (robots/sensors/actuators/machines) to develop virtual reality (VR) objects across geographically placed at the distant level. In other words, one can recognize passive and active interconnected haptic networks [16], where passive communication alludes to the exploration and recognition of the objects from remote distance and to determine characteristics without manipulating the objects in the remote environments. For the communication with real-world objects, it is required to sense the the haptic object characteristics from the remote site and and to send relevant information across the TI to the TC where a haptic screen display is used to present the

TABLE 1. List of abbreviations acronyms used in this paper.

Acronyms	Full description
3GPP	3 rd generation partnership project
5G	5 th Generation
ACB	Access Class Barring
AV	Audio and Video
BET	Blind Equivalent Throughput
CB	Code Blocks
CCA	Clear Channel Assessment
CSI	Channel State Information
DCI	DL Control Information
DL	Downlink
E2E	End to End
EDT	Early Data Transmission
eMBB	Enhanced Mobile Broad-Band
eNB	Evolved Node B
EWMA	Exponentially Weighted Moving Average
FEC	Forward Error-Correction
FRL	Federated Reinforcement Learning
gNB	Next Generation eNB
GPF	Generalized Proportional Fair
H2M	Human-to-Machine
HARQ	Hybrid Automatic Repeat Request
IoT	Internet of Things
ITU	International Telecommunication Union
LBT	Listen-Before-Talk
LTE	Long-term Evolution
LTE-LAA	Licensed-Assisted Access
M2M	Machine-to-Machine
MAC-RA	MAC layer Resource Allocation
ML	Machine Learning
mMTC	Massive Machine Type Communications
NOMA	Non-orthogonal Multiple Access
NR	New Radio
OC-HARQ	Outer Code-based HARQ
OFDM	Orthogonal Frequency-division Multiple Access
PDCCH	PHY DL control channel
PDF	Probability Density Function
PER	Packet Error Rates
PHY	Physical Layer
PSS	Primary Synchronization Signal
PUCCH	PHY UL Control Channel
QCI	QoS Class Identifier
RACH	Random-Access Channel
SCS	Sub-Carrier Spacing
SIC	Successive Interference Cancellation
SNR	Signal-to-Noise Ratio
SPS	Semi-persistent Scheduling
SR	Scheduling Request
TA	Tactile Actuators
TC	Tactile Core
TDD	Time Domain Duplex
TI	Tactile Internet
TSN	Time-Sensitive Networking
TTI	Transmission Time Interim
TXOP	Transmit Opportunity
URLLC	Ultrareliable Low Latency Communications
VR	Virtual Reality
VR-HARQ	Variable-Rate HARQ

information together with audio/video (AV) [17].

As per the URLLC requirements, E2E latency in the network ought to be less than one millisecond to maintain a real-time cyber-physical system (haptic network) for TI, where the assertions among visual, vestibular, and proprioceptive tactile systems regularly happen [18]. The E2E latency incorporates the time spent on the embedded computing on the sensing

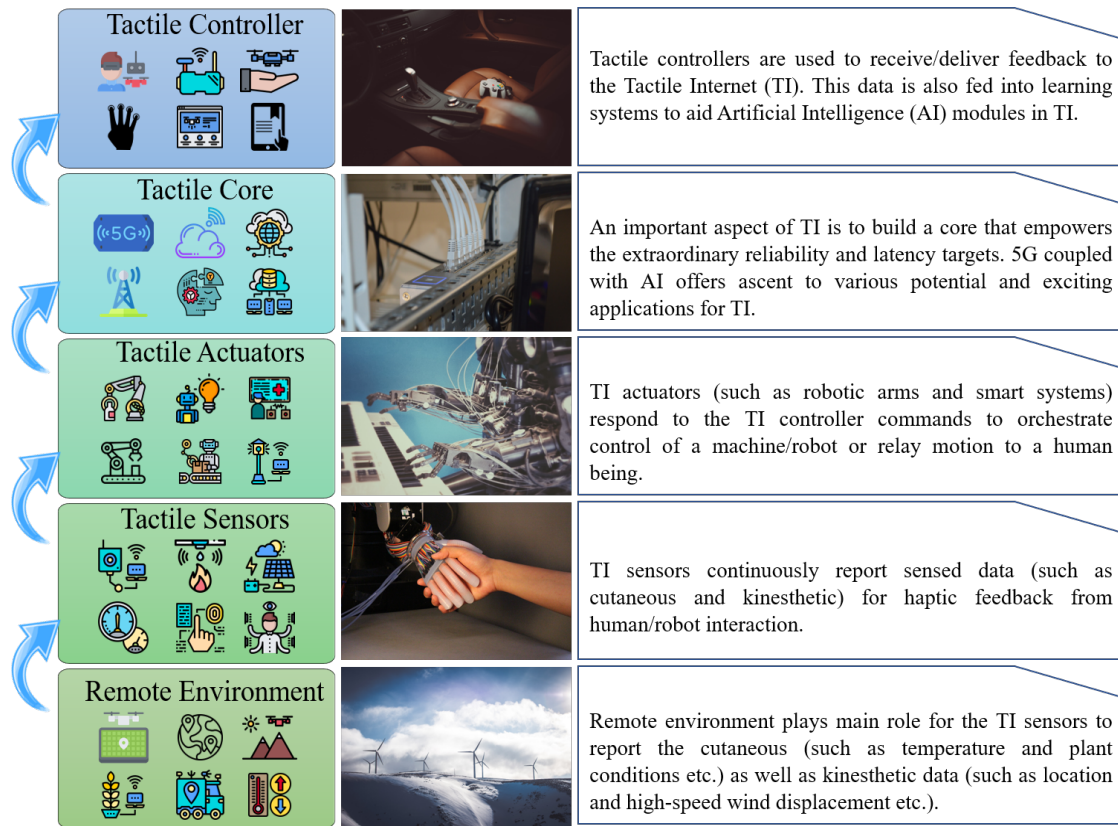

FIGURE 1. A typical TI operation, in which major components and functional requirements at various stages are highlighted.

data from the remote environment which includes tactile sensors (TS), data transmission to/from the control/steering server possibly on the TC, and the data processing in the tactile actuators (TA) as shown in Figure 1. Moreover, encouraged by the numerous attractive applications of TI, such as industrial automation, remote surgery, and process control, the need for the URLLC is emerging alongside the ultrahigh-reliable demands [8]. For example, in industrial automation, the reliability requirement in terms of packet error rates (PER) is required to be as low as 10^{-5} , and in factory automation, this requirement always turns out to be less than 10^{-7} [19].

B. NEED FOR 5G NR

The 3GPP partnerships are making tremendous efforts to define the 5G NR access technology [11]. The need for 5G NR technology is based on the adaptability of using the alternative communication spectrum in a wider environment and addressing specific use cases, to have the option of meeting its goals and objectives [20]. 5G NR characterizes various numerology that specify the sub-Carrier spacing (SCS) and the cyclic prefix overhead to handle a wide range of frequencies and deployment situations [11]. An evolved Node B (eNB), also known as the next-generation eNB (gNB) for 5G NR, will also have access to various types of networks, such as enhanced mobile broad-band (eMBB), massive machine

type communications (mMTC), and entirely URLLC requirements. Hypothetically, the 5G wireless communication model's physical layer (PHY) tends to be an approximation of being the better choice of the best possible numerology for gNB in a latency-throughput trade-off, that is, larger SCS is efficient in reducing URLLC latency, while lower SCS is efficient for high PHY layer throughput execution in eMBB traffic. 5G NR was governed in December 2017 by 3GPP with the first set of specifications known as Release 15 [14] and a detailed set released in June 2018; Release 16 for 5G NR is released in September 2019 [21], which consists of a set of specifications that corresponds to the 5G NR regulatory standards of the international telecommunications union (ITU), as previously stated.

C. RECENT ADVANCES FOR 5G NR

3GPP initially standardized 5G as two elements of radio technology; one is referred to as a novel radio system denoted as 5G NR, and another is LTE. In [22], it is shown that both 5G NR and LTE are able to meet the fundamental specifications of ITU 5G NR. New shorter slot structures allow faster uplink (UL) and downlink (DL) transmission to engage URLLC services, known as 5G NR mini-slots and transmission time interim (TTI) for the LTE radio interfaces. In addition, strategies for enhancing the efficiency of URLLC specifications, such as dynamic channel coding and

TABLE 2. Summary of Release 17 enhancements to existing as well as new features of the 5G NR related to URLLC requirements.

Feature	Existing/New	Important Characteristics
URLLC support	Existing	<ul style="list-style-type: none"> Improved support for URLLC including PHY layer feedback improvements and enhanced support for synchronization Recognizable proof of upgrades for URLLC techniques in controlled conditions on unlicensed spectrum
Indoor Positioning	Existing	<ul style="list-style-type: none"> Horizontally and vertically higher accuracy with lower latency, especially for industrial IoT
SideLink	Existing	<ul style="list-style-type: none"> Focus on Vehicle to everything (V2X), public security and business use cases Resource Allocation improvements Discontinues reception of SideLink
RAN Slicing	Existing	<ul style="list-style-type: none"> Enabling UE's faster access to the cell supporting the slicing Mechanisms to help service continuity for intra-RAT handover service interference
Anything Reality (XR)	New	<ul style="list-style-type: none"> Evaluate needs in terms of simultaneously giving high data-rates and most reduced latency in an resource efficient way Planned to help different types of augmented reality (AR) and virtual reality (VR), collectively referred as XR
5G NR on higher frequencies	New	<ul style="list-style-type: none"> Proposed to use higher frequencies for 5G NR (5G NR > 52.6 GHz) Provides excellent capacity for the operators in specific use cases for indoor/outdoor dense wireless network scenarios. Most of the spectrum in higher frequencies is unlicensed. Thus, it is committed to explore changes to support unlicensed operation in those frequencies.
Integrated Access and Backhauling (IAB) enhancements	New	<ul style="list-style-type: none"> The IAB solution was already introduced in Release 16, which is further evolved to provide increased efficiency and support additional use cases for Release 17. In disaster management applications, it can be critical to enable ad-hoc and temporary IAB nodes.

modulation and distinctive flexibility schemes, are provided in compliance with the architecture criteria of 5G NR and LTE. Effective bandwidth and productive power theories and models can be used as an analytical tool to test as much data as possible for the given limitations of latency and reliability [23]. Use a shorter subframe length to deferral the transmission of a decreased hybrid automatic repeat request (HARQ) could diminish latency. The revised methods [24] for encoding control data and information, such as combining the headers and data sections of the short packets, can be effectively coded for faster transmission with lesser error. Nevertheless, because all user equipments (UE) throughout the network has to decipher the combined packet, energy efficiency is off exchanged in this way. The research endorsed by the 3GPP in Release 16 will prompt the implementation of new highlights for the three case groups of essential use: eMBB, URLLC, and mMTC. The aim is to help the normal development of data traffic on mobile devices. The updates to existing 5G NR features introduced in the upcoming Release 17 [25] will be for functionalities already defined in 5G NR systems or may apply to specifically new prerequisites that arise in society. Table II summarizes the scope of the current improvements as well as the scope of the latest

5G NR functionality relevant to URLLC specifications in the forthcoming Release 17. Section II addresses a detailed discussion on the position and developments of 5G NR for URLLC requirements.

D. NEED FOR NEW MAC PROTOCOL FOR 5G NR

Both the time over the air and the transmit opportunity (TXOP) waiting delay are reduced by decreasing the transmission slot and interval. Such mini-slots that can be scheduled at short periodicity produce the lowest latency. Subsequently, mini-slots in 5G NR are the key design choices. Furthermore, for time domain duplex (TDD) systems, a short UL-DL exchanging period is essential to accomplish low latency. Likewise, short turnaround times empower more retransmissions inside a latency limitation, which can be converted into effective MAC-RA efficiency. A shorter turnaround is empowered by faster data processing in the network and on the UE side [26]. For the UL transmission, a critical part of latency comes from the exchange of a scheduling request (SR) and a UL transmission grant between the UE and the eNB. Besides, from a reliability perspective, this scheduling carries the hazard that both messages require to be accurately decoded for the UL transmission to begin.

As a solution for both the deferral and robustness issues, periodic channel access can be allowed for the UEs. 5G NR specifies semipersistent scheduling (SPS) mechanism for this purpose [27]–[29], in which the UE is given periodic channel access that it utilizes only when it has UL data to transmit. Substantially, by overlapping channel access to multiple UEs in MAC-RA, the resource waste is reduced. This strategy for periodic MAC-RA reduces the latency to empower URLLC requirements for UL transmission. Thus, multiplexing data with various TTI duration is one of the solutions for latency efficiency. For instance, in 5G NR DL transmission, a mini slot conveying delay sensitive information can acquire an already on-going TXOP on the first available OFDM symbol without waiting until the availability of the next TXOP.

For this purpose, contention-free and contention-based nonorthogonal multiple access (NOMA) mechanism for MAC-RA is proposed, which exploits the benefits of nonorthogonal signal superposition [30]. In contention-free transmission, random-access signaling cooperation and a scheduled channel access grant are required from the eNB before data transmission, which results in a delay of several milliseconds. However, in contention-based NOMA, data transmissions are independently initiated by the UEs without the explicit grant from the eNB, which extraordinarily lessens the control plane latency caused by signaling handshakes [31], [32]. Still, researchers are continuously contributing to explore novel potential MAC-RA mechanisms for 5G NR. Therefore, it is very critical to outline the endeavors and proposals presented by the research community related to prospective MAC protocol for 5G NR to achieve URLLC requirements.

E. SURVEY SCOPE AND OUTLINE

In this survey, we aim to offer a comprehensive insight into the need for a potential MAC protocol for 5G NR, which is one of the enablers for URLLC in TI. This paper looks at different aspects of MAC-RA mechanisms for 5G NR. First, we define the need for 5G NR from the URLLC perspective in order to provide the reader with an idea about the concept of the 5G NR in general and its possible framework for TI. For a comprehensive study, we cover both the PHY layer and MAC layer aspects in 5G NR. In terms of the PHY layer, we investigate the use of spectrum and its related techniques, such as bandwidth, coding schemes, diversity order, signal-to-noise ratio (SNR), and flexible OFDMA mechanisms. In addition, we list and overview the different PHY layer access technologies that are especially proposed for URLLC requirements, while identifying the main elements influencing the 5G NR performability to achieve URLLC. On the other hand, the relevant MAC layer and channel access mechanisms used in 5G NR to assure URLLC requirements to the TI have been explored in detail. We outlined and analyzed potential MAC-RA channel access mechanisms in 5G technologies in the literature. For this purpose, we explored the existing unlicensed spectrum technologies for URLLC requirements and discussed one of the recently

introduced unlicensed Wi-Fi standard, IEEE 802.11ax. For more uniform and intelligent MAC protocol for 5G NR, we discussed the role of reinforcement learning (RL) techniques for MAC-RA in unlicensed technologies. We further present potential future research opportunities for 5G NR to achieve URLLC in TI.

In general, this paper aims to gather and zoom in critical design aspects for next-generation enabling technologies and network intelligence for 5G NR URLLC requirements that might be of interest to readers from academia, as well as the industry. It provides a detailed discussion for those who are interested in reliable and low latency communication technologies for TI applications. In addition, this paper also opens the door for further exciting research projects and implementations. While the main objective and scope of this paper remain the enabling next-generation technologies for 5G NR, we discuss the role of FRL techniques for 5G technologies and identify emerging application domains intimately connected to these research areas. Generally, our survey paper distinguishes itself from earlier surveys from multiple perspectives, such as (Table III presents a comparative summary of this paper with existing reviews, tutorials, and magazine papers),

- We mainly focus on emerging next-generation technologies and network intelligence in 5G NR for URLLC requirements, instead of broadly discussing MAC/PHY layer techniques, or centering on a single application with a specific platform, for example, millimeter Wave (mmWave).
- This paper discusses cutting-edge ML mechanisms, such as FRL techniques from the perspective of MAC-RA mechanisms in 5G NR for URLLC requirements, focusing on their applicability to this research area, whilst giving less attention to conventional ML models that may be out-of-date.
- We also propose seven potential FRL-based frameworks for 5G NR URLLC requirements.

F. SURVEY ORGANIZATION

We structure this article by six parts in a triangular manner, as shown in Figure 2. This survey paper's tripartite structure sketches the adjacent sections of the paper filled with detailed discussion and tutorial about the subject, as shown in Figure 2. As shown in the figure, we begin by discussing research that gives the URLLC a high-level overview of 5G NR, which helps to establish the path to this paper's scope and contributions (Section II). Because the definition of 5G NR for URLLC services in wireless communication technologies is relatively new, in Section III we provide the necessary background of MAC-RA mechanisms in 5G NR for URLLC requirements, outlining possible channel access mechanisms to meet URLLC requirements. This segment also highlights the researchers' efforts to propose prospective pathways for MAC-RA in 5G NR. We also address unlicensed spectrum technologies for URLLC requirements (Section IV), which aim to help researchers and engineers understand the role

TABLE 3. Summary of related survey and review papers regarding 5G MAC protocol, 5G New Radio, and URLLC for Tactile Internet/IoT. In this table, we summarize the scope of the related surveys/reviews along with a short summary of the papers. At the end of the table, the contributions of our study are also shown to indicate the difference of the survey paper.

TI: Tactile Internet, **MAC:** MAC Layer, **FRL:** Federated Reinforcement Learning, **PHY:** PHY Layer, **URL:** URLLC.

✓: Included, X: Not included, †: Partially Included.

M: Magazine, **R:** Review, **S&T:** Survey & Tutorial, **S:** Survey.

Reference	Type	Scope of the paper					Remarks
		TI	MAC	FRL	PHY	URL	
J. Sachs <i>et al.</i> (2018) [13]	M	X	†	X	✓	✓	This article discusses the usefulness of both the 5 G NR and LTE radio interfaces to satisfy URLLC requirements. It determines feasible latency limits and demonstrates the predicted spectral effectiveness.
G. J. Sutton <i>et al.</i> (2019) [33]	S&T	†	✓	X	✓	✓	In this paper, the state of the art needs of the URLLC from the point of view of the PHY and MAC layer are overviewed. This paper acknowledges that allowing LTE to coexist in the unlicensed spectrum is additionally a possible enabler of unlicensed band URLLC criteria and offers numerical evaluations.
Y. Niu <i>et al.</i> (2015) [34]	S	X	†	X	✓	X	Technological problems are being assessed, such as achieving MIMO and full-duplex in-band at mmWave frequencies for 5 G NR.
A. Nasrallah <i>et al.</i> (2019) [35]	S&T	X	X	X	X	✓	Consideration of main front-haul, back-haul, and network management categories to support URLLC services in 5G networks.
L. Tian <i>et al.</i> (2017) [36]	M	X	†	X	✓	✓	Grant-free NOMA for uplink data transmission for 5G networks is elaborated in this paper.
N. Ye <i>et al.</i> (2018) [37]	S	X	✓	X	†	X	Grant-free NOMA with uncoordinated connections to UL, which is supposed to solve massive connectivity requirements for the 5G networks.
L. Dai <i>et al.</i> (2015) [38]	M	X	✓	X	X	†	Unlike traditional OFDMA technologies, NOMA can handle many more users by non-orthogonal allocation of resources. This paper divides current dominant NOMA schemes into two categories; power-domain multiplexing and code-domain multiplexing.
K. I. Pedersen <i>et al.</i> (2016) [39]	M	X	X	X	✓	✓	A data frame structure is proposed based on PHY layer control signaling that parallels the corresponding data transmission in the 5G network for each individual UE. A comparison is made to corresponding LTE design choices.
B. Farhang-Boroujeny <i>et al.</i> (2016) [40]	S&T	X	X	X	X	✓	This paper builds a typical structure based on the OFDM scheme and defines new waveforms. This induction provides another perspective which fosters a clear understanding of channel equalization and the use of new waveforms to MIMO channels.
M. S. Elbamby <i>et al.</i> (2018) [41]	M	✓	X	X	X	✓	This article addresses the URLLC services for VR problems and enablers.
H. Chen <i>et al.</i> (2018) [42]	M	✓	†	X	†	✓	Initially this article discusses three emerging critical uses of URLLC and sets out their prerequisites for E2E latency and reliability. This also examines the various origins of existing wireless communication networks, such as the 4G LTE, for E2E latency.
M.-T. Suer <i>et al.</i> (2019) [43]	R	X	†	X	†	✓	This paper offers an overview of multi-connectivity methods developed in standardization IEEE and 3GPP, and addresses layer-by-layer approaches to recent multi-connectivity.
I. Althamary <i>et al.</i> (2019) [44]	S	X	X	X	X	†	This paper includes a survey of vehicular networks-related research issues such as resource management, data offloading, cache positioning, URLLC requirements and high mobility.
S. K. Sharma <i>et al.</i> (2019) [45]	S&T	X	✓	X	X	†	A summary of the functionality of massive Machine Type Communication (mMTC) and QoS provisioning problems and provides primary enablers for mMTC in 5G networking.
X. Jiang <i>et al.</i> (2019) [46]	M	X	✓	X	✓	✓	This paper offers a systematic study and description of the core concepts of design and enabling technologies which will allow the implementation of URLLC services-based networks.
This study (2020)	S	✓	✓	✓	✓	✓	This paper summarizes the corresponding reliability and latency requirements for URLLC and proposes a ML-based future MAC protocol for the 5G NR PHY layer.

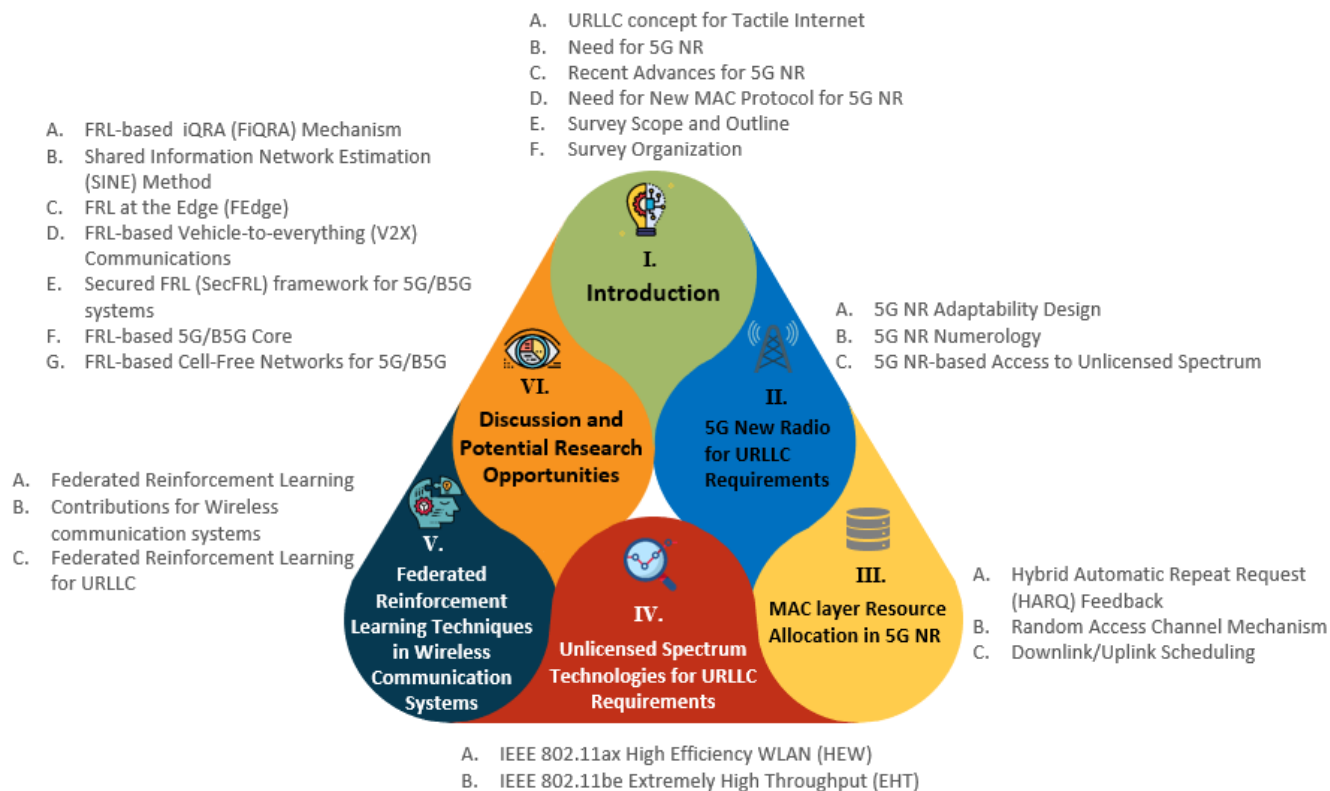

FIGURE 2. Diagrammatic view of the structure of this Survey paper.

of unlicensed spectrum technologies in 5G NR requirements as incumbent technologies for URLLC. In Section V, for URLLC requirements we present the FRL techniques for wireless communication systems to solve channel access problems in 5G NR. Section VI addresses and suggests seven potential FRL-based frameworks for 5G NR as future directions for the study. Finally, this article is concluded in Section VII.

II. 5G NEW RADIO FOR URLLC REQUIREMENTS

Two aspects for TI service providers are based on configuring the wireless radio network. First, a URLLC is required; second, anticipated and measurable output of the allocation of wireless resources is needed. It needs the 5G system to reveal its E2E resource allocation capacity, which is configured accordingly. This section describes key efforts taken by the researcher to achieve such URLLC requirements.

To allow a 5G radio network to meet URLLC requirements, the researchers, as well as the industrialists, are pursuing two parallel progressive technology tracks. As stated earlier, they proposed to work on the redesign of the LTE radio interface currently being introduced and the other is 5G NR interface. 3GPP introduces URLLC services using LTE in Release 15 [14], and addresses the 5G specifications for comparison. The development of the LTE may be put into existing LTE networks and resource allocation mechanisms. This includes

backward compatibility to 5G networks, which ensures the existing LTE-evolved UE will use novel 5G functionality. At the same time, legacy LTE UEs will continue to operate with the current services under the same LTE system. However, 5G NR is not limited to [47] backward compatibility only, and also explores design possibilities for a new system. In addition, 5G NR explores new use of the 5G spectrum, providing a frequency range of 6 GHz. One approach to accomplishing this adaptability to specific spectrum ranges is the [12] numerology scaling (we discuss 5G NR numerology in more detail in later subsection).

A. 5G NR ADAPTABILITY DESIGN

The fundamental aspect of the 5G NR PH layer is its flexibility; the specification itself offers an overall implementation architecture designed to resolve the extraordinary, and often changing, forward backward compatibility requirements. The fundamental function of such program is that it can engage in future applications and use cases of TI [48]. 5G NR uses modulations for the OFDM channel which isolates accessible channel resources in 10 ms frames with 1 ms subframes. In addition, subframes are partitioned into slots and symbols, where the example of a single OFDM symbol and a single subcarrier constructs the smallest channel resources in 5G NR. While at current LTE, 5G NR addresses the fixed symbol length and the SCS. Various OFDM numerology may be

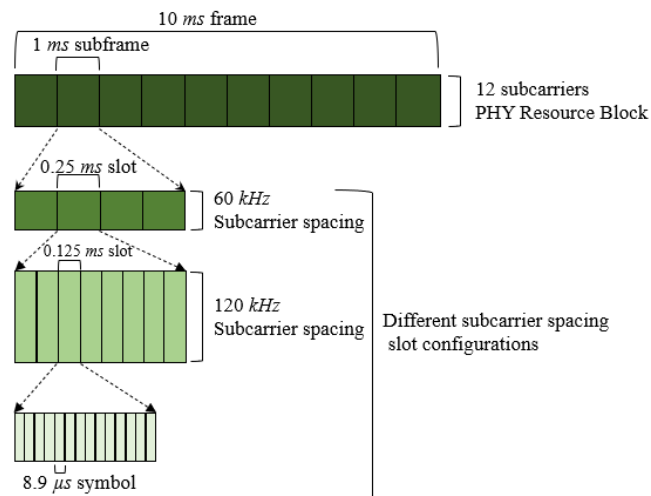

FIGURE 3. 5G NR frame structure with two different SCS.

constructed at a subframe premise. Therefore, each subframe is independent and can be interpreted by a substitute numerology [12]. It makes it feasible to tackle distinctive 5G use cases with a single RAT: for example, a shorter OFDM symbol length, along with a higher SCS, can be used for [12] higher data rate and low-latency communication. Figure 3 is a case of a 5G NR outline structure with two different conceivable SCSs.

B. 5G NR NUMEROLOGY

The 5G NR RAT has an adaptable OFDM architecture to allow wide spectrum connectivity, multiple implementation scenarios, and to tackle diverse use cases [14]. It is defined in [14] that the 5G NR offers the ranges up to 52.6 GHz and characterizes two frequency ranges; frequency range 1 (FR1), which includes sub-6 GHz frequency spectrum, and frequency range 2 (FR2), which includes mmWave with 24.25-52.6 GHz; Frequency ranges greater than these, which are not yet specified, are required to be part of 5G NR Release 16 and Release 17. In view of the adaptability, 5G NR combines various numerologies, each being represented by a SCS and a cyclic prefix (CP) [10]. A 5G NR numerology (represented as μ) ranges from 0 to 4 and displays a $15 \times 2^\mu$ kHz SCS and a $\frac{1}{2^\mu}$ ms slot period. The 5G NR upheld SCSs are within the range of 15-240 kHz, defined in Release 15 [14], where higher carrier frequencies are used for larger SCSs. However, as indicated in Release 15, some of the numerology is not used by every physical resource, for example, $\mu = 4$ is not used for data channels, and $\mu = 2$ is not used for [14] synchronization channels. In addition, only $\mu = \{0, 1, 2\}$ in FR1, and $\mu = \{2, 3\}$ in FR2 are used for data channels. 5G NR Release 16 and Release 17 are expected to implement larger μ , and implementation decisions will be integrated for the mmWave range. Under 5G NR, the number of SCSs per PHY resource block (PRB) is set at twelve with the target being $180 \times 2^\mu$ kHz the width of the PRB is equivalent. As

stated earlier, for backward compatibility, 5G NR includes frame length 10 ms and subdivides it into 10 subframes of 1 ms each. Every subframe has a slot number of $\frac{1}{2^\mu}$ which depends on the configuration of 5G NR numerology, as shown in Figure 4, and 14 OFDM symbols requires a slot time. In this way, the $\frac{1}{14 \times 2^\mu}$ ms [25] is the OFDM symbol size barring CP. Fig 3(b) indicates the limits of different 5G NR numerology, where $\mu = 0$ relates to LTE device architecture, while $\mu = \{1, 2, 3, 4\} > 0$ engages greater bandwidth and shorter TTI, which is useful for mmWave spectrum and URLLC requirements [12]. In comparison to LTE, in 5G NR, the SCS and the OFDM symbol duration can have different values depending on the numerology being considered, along with certain decisions, the TTI and the E2E latency can be minimized [49].

Furthermore, 5G NR combines small individual slots and mini-slots to fulfill the URLLC requirements [25]. The small independent slot includes data and control information for a similar slot, such as HARQ feedback or UL channel award, to achieve reduced latency by reducing a deferral in signaling response. For example, acknowledgment (ACK) or negative ACK (NACK) accesses the same slot for transmission of information from DL, or in the same slot for transmission of information from UL. On the other hand, the purpose of mini slots to reduce the latency by giving more adaptability to the transmission of the small size data packets. These mini slots are made of two OFDM symbols of slot length 1 in any band, and of 1 symbol, in over 6 GHz range.

C. UNLICENSED SPECTRUM ACCESS USING 5G NR

It is obvious that the 3GPP is in a full RAT standardization process for TI applications using 5G NR, without a doubt, which has substantial support for activities at higher carrier frequencies (such as mmWave) [50], [51]. One of the options considered is to allow 5G NR to work in an unlicensed spectrum, referred as 5G NR-U. However, 5G NR-U resembles what was recently proposed for the 5 GHz frequency in LTE unlicensed (LTE-U) spectrum, with its different variations [52], [53], specifically LTE-based Licensed-Assisted Access (LTE-LAA) [54].

The design proposal of 5G NR-U began in a 5G NR release 16 (2018) [55] research report, and is now included as one of 5G NR Release 17 working parts [25], which will empower its use cases in future 5G NR specification [56]. Its main objective is to loosen the importance 5G NR to unlicensed spectrum as a significant technology that works across different bands and uses a system that ensures fair coexistence across different RATs [54]. However, LTE-U and LTE-LAA rely on carrier aggregation using the unlicensed 5 GHz band, whereas 5G NR-U considers different bands and mode of deployment. Actually the unlicensed frequency bands of 2.4 GHz, 5 GHz, 6 GHz, and 60 GHz are examined for 5G NR-U. The 60 GHz band is an appealing opportunity for 5G NR-U as it is not very crowded at the moment and can offer greater transmission capacities [56]. Some of the most challenging issues regarding allowing 5G

Numerology μ	SCS kHz	Symbol μs	CP μs	Subframes	Slots in a subframe	Slot length μs	Symbols in a slot	Subcarriers in a PRB	PRB size MHz
0	15	66.67	~4.8	10	1	1000	14	12	0.18
1	30	33.33	~2.4	10	2	500	14	12	0.36
2	60	16.67	~1.2	10	4	250	14	12	0.72
3	120	8.33	~0.6	10	8	125	14	12	1.44
4	240	4.17	~0.3	10	16	62.5	14	12	2.88

FIGURE 4. The list of 5G NR Numerology.

NR to operate in an unlicensed environment is maintaining a fair and equitable coexistence with other unlicensed technologies. For example, IEEE 802.11 Wireless Local Area Network (WLAN) [15], [57], [58] and Multiple Gigabit Wireless Systems (MGWS) [59]–[61] in the 60 GHz band, (such as IEEE 802.11ad / ay) [59]–[61]. In the unlicensed spectrum, fair coexistence for 5G NR-U is defined as the ability that 5G NR-U UEs do not impact existing WLAN more than that of any WLAN deployment. For a fair coexistence, any RAT planning to enter the unlicensed spectrum must be arranged according to the regulatory specifications of the currently deployed unlicensed technologies. For example, the 3GPP commands the use of listen-before-talk (LBT) in Europe and Japan [54] [62], because of 5 GHz technologies. LBT is a MAC-RA mechanism by which a UE accesses the channel through a clear channel assessment (CCA) [63]. Recently, researchers have done a lot of research on the 5 GHz fair coexistence to allow LTE to coexist smoothly in unlicensed spectrum with WLANs [52]–[54] [62]–[65]. Unlike the current LTE, however, the ongoing 5G NR-U can be built from scratch with comprehensive adaptability and versatility to provide competent coexistence in the unlicensed spectrum. Whereas in the 5 GHz band, there is a critical differentiation between 5G NR-U coexistence with existing RATs as compared to LTE and WLAN coexistence due to beamforming (directional) massive MIMO (mMIMO) transmissions in 5G NR [51]. For increasing operating range, 5G NR proposed beam control techniques for gNB and UEs. This beamforming envisaged in 5G NR could reduce the obstruction of the channel and potentiate spatial reuse. It however increases the challenges in the unlicensed spectrum for the coexistence framework. In particular, beamforming can reinforce the issues of unlicensed bands on hidden/exposed devices [66]. Table IV highlights a list of the 5G/LTE cellular techniques using an unlicensed spectrum (refer to the references given for detailed description of the techniques).

III. MAC LAYER RESOURCE ALLOCATION IN 5G NR

Before we discuss MAC-RA schemes for URLLC in 5G NR, we briefly present some of the cross-layer mechanisms for URLLC requirements. These cross-layer techniques are also of great value while the channel resources are accessed. Hence at the beginning of this section, few of the cross-layer-related URLLC methods are examined and are also summarized in Table V. One of the motivations to classify cross-layer mechanisms is that they play a vital role in-between PHY layer and MAC layer for the data transmission. For example, the HARQ methods help to resolve automatic error-correction between the PHY layer and the MAC layer.

A. HYBRID AUTOMATIC REPEAT REQUEST (HARQ) FEEDBACK

HARQ is a significant part that gives conventional LTE the ability and reliability to change spectrum competence. HARQ is located in the MAC layer and uses forward error correction (FEC) to trigger additional transmission bits with extra error correction data when identifying an error or failing to resolve an error [73]. Given the fact that HARQ completely exploits time diversity to improve reliability, particularly in time-varying communication channels, more than one retransmission with URLLC requirements, that is, latency $< 1 ms$, is difficult to accomplish. HARQ would then have trouble contributing to URLLC specifications.

However, a cooperative HARQ which sets up a virtual radio reception channel array among gNBs is proposed to guarantee reliability under extreme shadowing and fading conditions [33]. A PHY DL control channel (PDCCH) is utilized for dynamic scheduling of DL control information (DCI) in 5G NR, which incorporates the data required for the UE to process the scheduled information [74]. To schedule a DL data, the DCI scheduling also incorporates channel resource information of the HARQ-ACK feedback. The UE uses this DCI scheduling information to transmit HARQ-ACK on the PHY UL control channel (PUCCH). However, for UL data transmission, there is no particular channel to receive HARQ-ACK feedback. Therefore, once gNB fails to receive the

TABLE 4. Catalog of cellular technologies that use unlicensed spectrum.

Cellular Technology	RAT	Standardization Organization	Release	Important Characteristics
LTE-U [67]	LTE	LTE-U Forum	Release-12	<ul style="list-style-type: none"> sub-7 GHz operational band, 5 GHz unlicensed band, 60 MHz aggregated bandwidth Up to 8 streams MIMO and up to 256 QAM Duty-cycle MAC-RA, HARQ-based Carrier aggregation of licensed and unlicensed spectrum
LWA [68]	Wi-Fi	3GPP	Release-13	<ul style="list-style-type: none"> Operational band sub-7 GHz A combined effort of LTE Release-13 and IEEE 802.11 standards PDCP level integration of LTE and Wi-Fi
LWIP [69]	Wi-Fi	3GPP	Release-13	<ul style="list-style-type: none"> sub-7 GHz operational band A combined effort of LTE Release-13 and IEEE 802.11 standards (Wi-Fi) IP level integration of LTE and Wi-Fi
LTE-LAA [70]	LTE	3GPP	Release-13	<ul style="list-style-type: none"> sub-7 GHz operational band, 5 GHz unlicensed band, 80 MHz aggregated bandwidth Up to 8 streams MIMO and up to 256 QAM LBT MAC-RA, HARQ-based Licensed/unlicensed spectrum carrier aggregation
eLWA [69]	Wi-Fi/WiGig	3GPP	Release-14	<ul style="list-style-type: none"> sub-7 GHz and above 7 GHz operational band A combined effort of LTE Release-14 and IEEE 802.11 standards (Wi-Fi/WiGig) PDCP level integration of LTE and Wi-Fi/WiGig
eLWIP [69]	Wi-Fi/WiGig	3GPP	Release-14	<ul style="list-style-type: none"> sub-7 GHz and above 7 GHz operational band A combined effort of LTE Release-14 and IEEE 802.11 standards (Wi-Fi/WiGig) IP level integration of LTE and Wi-Fi/WiGig
LTE-eLAA [71]	LTE	3GPP	Release 14	<ul style="list-style-type: none"> sub-7 GHz operational band, 5 GHz unlicensed band, 80 MHz aggregated bandwidth Up to 8 streams MIMO and up to 256 QAM LBT MAC-RA, HARQ-based Licensed/Unlicensed spectrum carrier aggregation, and dual connectivity
LTE-FeLAA [72]	LTE	3GPP	Release 15	<ul style="list-style-type: none"> sub-7 GHz operational band, 5 GHz unlicensed band, 100 MHz aggregated bandwidth Up to 8 streams MIMO and up to 256 QAM LBT MAC-RA, HARQ-based Licensed/Unlicensed spectrum carrier aggregation, and dual connectivity
5G NR-U [25] [55], [56]	5G NR	3GPP	Release 17	<ul style="list-style-type: none"> Operational bands; <i>sub - 7 GHz</i> and above 7 GHz, 2.4, 3.5, 5, 6, 37, 60 GHz unlicensed bands, 800 MHz aggregated bandwidth Up to 8 streams MIMO and up to 1024 QAM LBT MAC-RA, HARQ-based Licensed/Unlicensed spectrum carrier aggregation, and dual connectivity

UL data frame, a retransmission is requested for the UL data frame, whereas, if gNB effectively receives the UL data frame, a new UL data frame transmission is planned. Thus, one of the key differences between traditional LTE/5G and 5G NR is the profoundly symmetric properties of 5G NR in the DL/UL scheduling and HARQ feedback. In LTE, channel resource allocation schemes are diverse among DL and UL because of various channel access mechanisms. DL HARQ feedback is fundamentally asynchronous and adaptive, while UL HARQ is synchronous and non-adaptive. In 5G NR, a common approach between DL/UL is used for almost all scheduling and HARQ feedback, for example, channel resource allocation schemes and asynchronous and adaptive HARQ feedback [74]. Another key difference between the HARQ feedback mechanism in traditional LTE and 5G NR is its high adaptability in the time domain (TD). For example, in LTE, TD-based channel resources for scheduled data frames and/or HARQ feedbacks are essentially not informed by the DCI scheduling, and it is controlled by the transmission frame structure and the DL/UL alignment. In 5G NR, as presented in Figure 5, the DCI scheduling necessarily includes TD information of the scheduled data frame HARQ-ACK feedback (only for DL) where the TD information here refers to the scheduled time-slot, the position of the start symbol, and the duration of the data frame transmission. In this way, 5G NR can satisfy various UE's requirements, such as achieving URLLC and higher data rates. On the other hand, HARQ-ACK feedbacks for DL/UL data frames, a UE faces extra processing delay. Traditionally, the minimum processing delay for LTE is 3 *ms*, while 5G NR is successful to significantly reduce this processing delay, which is 0.2 – 1 *ms* for DL data and 0.3–0.8 *ms* for UL data.

Related Contributions

The cooperative HARQ enhances the reliability performance with a short retransmission delay and sharply reduces the block error rate (BLER) [75]. In [76], the authors analyze the effectiveness of HARQ and the effect of channel state information (CSI) feedback accuracy. They found that exact CSI feedback improves the channel reliability, and it is prescribed to utilize just a single retransmission to ensure low latency. However, URLLC prerequisites may not benefit by retransmission scheme, as it can cause network congestion and increases E2E delay. The 5G public-private partnership (PPP) [77] venture proposes to turn-off the HARQ feedback in certain situations to accomplish URLLC prerequisites. Turning off HARQ feedback has already proven its effectiveness in unlicensed bands, for example, in Wi-Fi, where a Wi-Fi-enabled station (STA) can work in two modes of services classes; No-ACK and ACK [15] [78].

In [79], the authors examine the effect of the accuracy of the CSI feedback on HARQ performance. Subsequently, these authors expanded their research to introduce a novel, assortment-based spatial data transmission scheme with cooperative HARQ to improve transmission trustworthiness in smart industry applications. In [80], a HARQ pooling

approach for multi-connectivity UE is suggested, in which complex and versatile HARQ splitting schemes are treated helpfully through various carriers to achieve URLLC prerequisites. For the transmission of data between UEs and eNB, Shariatmadari *et al.* [81] used E2E reliability. For a latency requirement of < 1 *ms*, and a TTI of 0.125 *ms* is used to allow four transmissions, which can occur on any link between a UE and an eNB. In their proposed method, these four transmissions and DL/UL resources are managed based on the instantaneous CSI of the two links to achieve high reliability in terms of BLER instead of equivalent allocation of resources to the DL/UL transmissions. In [81], authors devise the optimization issue of HARQ feedback using an incremental redundancy HARQ scheme, named as IR-HARQ. IR-HARQ suggests a sub-optimal HARQ procedure to overcome the complexity. However, their sub-optimal solution is further optimized by [82], in which authors propose a dynamic programming algorithm to maximize the throughput by optimally tuning the IR-HARQ parameters. Le *et al.* [83] highlighted the performance degradation of URLLC traffic with the increase of collision among the UEs and gNBs. To resolve this challenge, they proposed a two-step scheme, which includes an overlapping indication and HARQ feedback. An efficient retransmission scheme outer code-based HARQ (OC-HARQ) is proposed in [84], in which each receiving UE send HARQ feedback information based on the number of code blocks (CB). However, there is always a chance that all the retransmissions of a UE may not be successful as configured, thus reducing the reliability. In [85], the authors proposed two approaches to handle this issue; usage of the explicit HARQ feedback scheme and an additional scheduling request alongside the data frame. The problem of low data rates and reduced reliability in traditional LTE/5G can also be resolved with the help of a joint PHY layer and MAC layer scheme proposed in [86], which uses an artificial noise design in singular value decomposition based HARQ feedback. On the other hand, for the optimization of adaptation and allocation strategy for HARQ feedback, certain knowledge of the probabilistic model of the CSI is mandatory, such as the probability density function (PDF) of the signal to noise ratio (SNR) [87]. The variable-rate HARQ (VR-HARQ) scheme proposed in [88] assumes the variable lengths of the SCS for throughput enhancement in 5G networks. Strodthoff *et al.* [89] have proposed a machine learning-based scheme to predict the consequences of the decoding process ahead of the end of the data frame transmission. Table V summarizes the key features of the contributions of the researchers related to the HARQ feedback mechanism.

B. RANDOM ACCESS CHANNEL MECHANISM

One of the most basic sources of latency in 5G systems is the underlying link association with the assistance of a random access channel (RACH) method that causes several milliseconds delays [90]. This turns out to be particularly challenging for TI applications because of inconsistent com-

TABLE 5. Summary of contributions related to HARQ feedback mechanism.

Reference	Proposed mechanism	Key features
Serror <i>et al.</i> [75]	Cooperative HARQ	<ul style="list-style-type: none"> • A short retransmission delay is achieved using a cooperative HARQ mechanism • Sharply reduces BLER
Shariatmadari <i>et al.</i> [76]	Precise CSI feedback	<ul style="list-style-type: none"> • Analyzes the effectiveness of HARQ and the effect of channel state information (CSI) feedback accuracy • The channel reliability is improved with the use of a precise CSI • To guarantee low latency, use only single retransmission
Gao <i>et al.</i> [79]	Assortment-based spatial information transmission scheme with cooperative HARQ	<ul style="list-style-type: none"> • The impact of the accuracy of the CSI feedback on HARQ performance. • Extension to Cooperative HARQ. • A novel assortment-based spatial information transmission scheme with cooperative HARQ.
Sheshachalam <i>et al.</i> [80]	HARQ pooling: optimal scheme	<ul style="list-style-type: none"> • A HARQ pooling technique for multi-connectivity UEs. • Dynamic and versatile splitting HARQ schemes are cooperatively dealt over various carriers to achieve URLLC requirements.
Shariatmadari <i>et al.</i> [81]	Incremental Redundancy HARQ (IR-HARQ)	<ul style="list-style-type: none"> • Considered E2E reliability for data transmission between UEs and eNB. • For a less than 1 ms latency achievement, a 0.125 ms TTI is utilized to permit four transmissions • These numbers of transmissions and DL/UL resources are regulated based on the instantaneous CSI of DL/UL links to achieve high reliability in terms of BLER. • Suggests a suboptimal solution to overcome the complexity of HARQ feedback mechanism.
Avranas <i>et al.</i> [82]	Optimal tuning of IR-HARQ	<ul style="list-style-type: none"> • The suboptimal solution of IR-HARQ is further optimized using a dynamic programming algorithm. • Maximize the throughput by optimally tuning the IR-HARQ parameters.
Le <i>et al.</i> [83]	Two-step multiplexing strategy	<ul style="list-style-type: none"> • Highlighted the performance degradation of URLLC traffic with the increase of collision among the UEs and gNBs. • A two-step multiplexing scheme which includes an overlapping indication and HARQ feedback.
Yeo <i>et al.</i> [84]	Outer Code-based HARQ (OC-HARQ)	<ul style="list-style-type: none"> • Each receiving UE sends HARQ feedback information based on the number of CBs.
Le <i>et al.</i> [85]	Explicit HARQ structure	<ul style="list-style-type: none"> • Explicit HARQ feedback scheme and an additional scheduling request alongside the data frame.
Xia <i>et al.</i> [86]	MIMO HARQ scheme	<ul style="list-style-type: none"> • A joint PHY/MAC layer scheme to use an artificial noise design in singular value decomposition based HARQ feedback.
Szczecinski <i>et al.</i> [87]	DP to optimize truncated HARQ	<ul style="list-style-type: none"> • For optimization of adaptation and allocation strategy for HARQ feedback, specific knowledge of the probabilistic model of the CSI is mandatory. • The PDF of the SNR is highlighted. • Proposed simple linear rate adaptation policies to show how to optimize them via DP.
Shi <i>et al.</i> [88]	Variable-Rate HARQ (VR-HARQ)	<ul style="list-style-type: none"> • Assumes the variable lengths of the SCS for throughput enhancement in 5G networks. • Effective capacity for VR-HARQ has been investigated.
Strodthoff <i>et al.</i> [89]	Enhanced Machine Learning-based Early HARQ (E-HARQ)	<ul style="list-style-type: none"> • A machine learning-based scheme to predict the consequences of the decoding process ahead of the end of the data frame transmission.

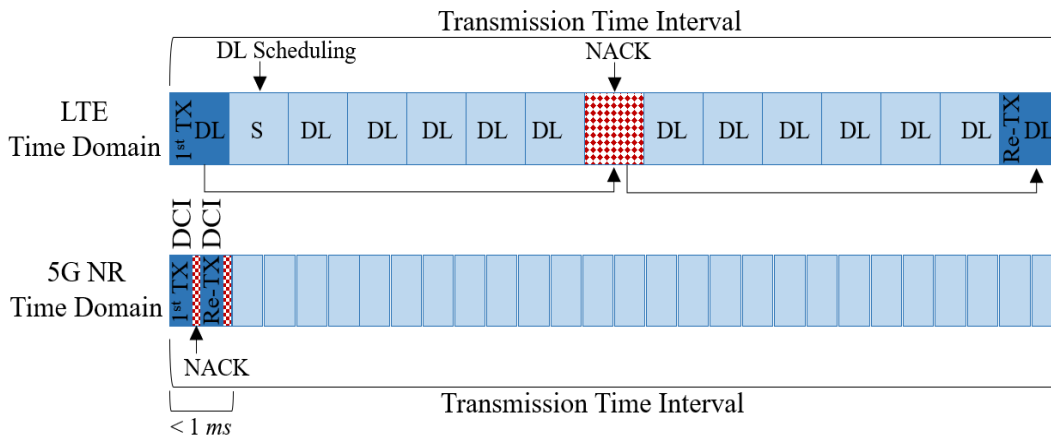

FIGURE 5. HARQ feedback mechanism in traditional LTE and 5G NR.

munications by the devices with URLLC requirements with a small data packets and contending for a fixed number of preambles. This prompts a genuine bottleneck at the MAC layer, especially in highly dense UEs environments. As a UE is first turned on, it interprets the primary synchronization signal (PSS) and secondary synchronization signal (SSS) to synchronize with the DL channels. After that, the UE isolates the master information block (MIB), which includes information about the DL/UL carrier configurations' position. The gNB obtains the data from the system information block (SIB). All random access (RA) parameters, such as RA slots, RA preamble classes, and preamble setup, are included in this SIB. Following that, UEs will make a RA transmission attempt after interpreting the SIB. In LTE/5G networks, the contention-based RA performs four main steps for affiliation initialization. Figure 6 depicts these four measures together with their details, as well as the basic 5G RACH process [91].

1) Preamble transmission (UE → gNB)

Contention-based RA is initiated by a UE choosing a randomly generated RA preamble from a uniform distribution and sending it to the gNB at the next available RACH slot. The gNB sends out SIB messages on a regular basis, allowing UEs to choose a suitable preamble from among them. The RA radio network temporary identification (RNTI) and the setup of the preamble data are included in the physical properties of the RA preamble in RACH. If the preamble is submitted, the UE waits for a RA answer (RAR) slot.

2) RA response (gNB → UE)

On RACH, the gNB measures the obtained preamble's power delay profile (PDP). This average PDP is compared to a predetermined threshold, and if it is higher, it is classified as an active RA preamble. The gNB decodes the RNTI for each active RA preamble to determine the RA slot where the preamble was sent. On the DL control message channel, the gNB sends a RAR message to the decoded UEs. The RAR message includes a timing advance (TA) instruction

to synchronize subsequent UL transmissions, a UL resource award for RRC specifications, and a short RNTI, which can be made secure throughout the contention resolution phase (CRP). However, a collision may occur due to simultaneous preamble transmission at a similar RA slot.

3) RRC connection request (UE → gNB)

As a result of allocated channel resources to a UE, it sends gNB an RRC link request as well as a scheduling request. In this step 3, a message to the temporary RNTI is sent that was allocated in the RAR message in step 2. If the UE already has one RRC-associated, it conveys either a particular RNTI, an initial UE identity, or a randomly chosen number. However, because of a collision in step 2, colliding UEs attempt to retransmit RA link requests using the same UL services, resulting in further network collisions.

4) RRC connection setup (gNB → UE)

After decoding the RRC request, the gNB acknowledges the UE in this phase, which is also known as CRP. The dedicated RNTI is used to send RRC link configuration messages. The successful UEs then send an acknowledgment to the gNB and proceed with data transmission. If the full number of retransmission attempts is reached, the collided UEs must wait before initiating a new contention-based RA procedure.

Related Contributions

Many researchers have suggested mechanisms to reduce the time spent waiting for the RA procedure in related research contributions. Early data transmission (EDT) as a feature of the Release 15 specification is one of the 3GPP's proposals [14]. EDT is one of the most appealing strategies for reducing the overhead exchange of association setup messages and shortening overall latency in transmission. In EDT, data transmission services from the UL channel are sent earlier allowing data packet transmission to be piggybacked with the RACH system. The authors of [92] provided some underlying results on the execution of EDT, demonstrating

TABLE 6. Summary of contributions related to RACH procedure.

Reference	Proposed mechanism	Key features
3GPP [14]	LTE RACH	Proposed early detection transmission (EDT) to reduce RACH association setup time. Data packet transmission piggybacked with RACH procedure
Hoglund et al. [92]	Evaluation of EDT RACH process	Fundamental results of EDT RACH procedure to reveal improvements of RACH procedure in reduced latency
Condoluci et al. [93]	CAM RACH	Critical Alarm Messages RACH procedure and two-way handshake association process. Reduced latency 10-50% for macro and 50-70% for femto cells
Chen et al. [94]	Reserved RACH	Prioritized reserved RACH resources for URLLC requirements. Less than 10 ms latency is achieved for 95% of the UEs
Ashraf et al. [95]	5G/NX	System level simulations for LTE/5G networks. Evaluated the LTE/5G networks for URLLC applications
Leyva-Mayorga et al. [97]	ACB in LTE/5G	Analytical framework for the evaluation of ACB in LTE/5G networks. ACB fails to satisfy requirements for URLLC applications
Jiang et al. [98]	Repeated RA preamble	Stochastic geometry model to enhance network reliability with the help of repeated RA preambles
Vural et al. [99]	Assorted RA Preambles	Numerous RA preambles in a single RACH process. Use of lower preamble group size for saturated resource utilization
Thota et al. [100]	PP, DRP, EBF	Proposed three novel RACH procedure enhancements; Parallel Preambles (PP), Dynamic Reserved Preambles (DRP), enhanced back-off (EBF). Reduces channel Collision probability
Arouk et al [101]	Analytical model of RACH	Models the performance of RACH procedure. Dedicated to use for any RA distribution. Can be utilized for any congestion control mechanism for ACB
Choi et al [102]	Generalized RACH-less handover	A RACH-less handover scheme for seamless mobility in 5G networks. Achieves URLLC requirements by avoiding RACH procedure. Significantly reduces the handover latency
Choi [103]	Adaptive RA preamble pool	Models RACH procedure with fast retrieval. Throughput maximization without knowing the number of UEs
Moussa et al. [105]	Stochastic Geometry-based Mathematical Model for RACH procedure	Analyzes the capabilities of RACH process. Can be utilized for any contention-based RA mechanism. Framework accounts for network density, spectrum characteristics of the network, utilized power control, and interference in the network.
Reddy et al. [106]	SIC-based RACH procedure	Successive Interference Cancellation (SIC) for higher RACH success rate. Significantly improves the performance of RACH procedure for mMTC
Bui et al [107]	DQ-based CR	Distributed Queuing-based contention resolution in RACH procedure. Assisted by MAC layer network estimation methods. Significantly reduced access delay and energy consumption
Bello et al. [108], [109]	FA-QL-RACH	Frame ALOHA for Q learning-based RACH procedure. Collision-free RACH for machine-to-machine networks
Bello et al. [110]	Improved FA-QL-RACH	Dynamic adaptation of back-off periods for RACH procedure

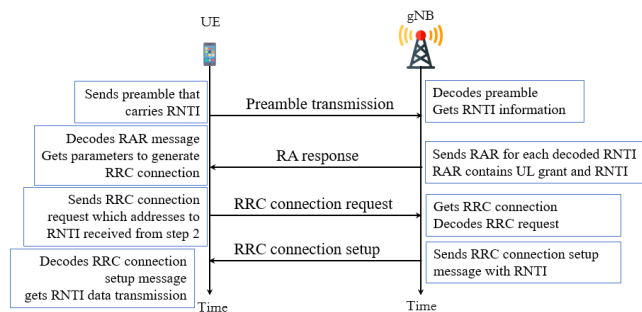

FIGURE 6. Contention-based random-access procedure in an LTE/5G network.

that it improves in-data packet latency by 85 ms at the network edge. Condoluci et al. [93] performed efficiency tests to demonstrate that a two-way handshake RACH mechanism is built on an unusually standardized RA preamble that guarantees a 10%-50% delay reduction for 5G macro-cell networks and a 50%-70% delay reduction for femto-cell 5G

networks as compared to the regular RACH process. In [94], a novel RACH resource system for URLLC-related traffic is proposed, which is referred to as resource allocation priorities. According to the authors, by reserving twice as many RA preambles as URLLC-based UE demands, a channel access latency of less than 10 ms can be achieved for 95% of URLLC-based UEs. In [95], a system level simulation is performed to show that LTE/5G wireless networks do not support rigorous latency prerequisites for 5G NR URLLC applications with an adaptable PHY layer numerology. In addition, the RAN enhancements for LTE in [96] included various access class barring (ACB) with many back-offs depending on QoS criteria. Another similar contribution in [97] presents simulation results using analytical system architecture to demonstrate that ACB fails to meet the criteria for URLLC achievements of 3GPP control planes. By repeating RA preambles to increase the chance of success in RACH, Jiang et al. [98] constructed a stochastic geometry model for assessing the impact of diversity. In a dense implementation of the UE, their study reveals that repeating the RA pream-

ble results in inefficient use of wireless channel resources. Furthermore, according to Vural *et al.* [99], the advantages of using multiple RA preambles in the RACH phase can be seen with smaller preamble group sizes, up to 20, as resource consumption saturates with repetitive transmissions. According to their findings, in a dense implementation of the UE, repeating the RA preamble results in inefficient use of wireless channel resources. Besides that, Vural *et al.* [99] found that using multiple RA preambles in the RACH system results in a lower preamble group size of up to 20 as resource consumption saturates with repetitive transmissions. RA improvements therefore include implementation of short transmission slots of 5G numerology, quicker transmission of UL data packets, efficient back-off times for QoS-based traffic, and dedicated resource allocation for URLLC applications to reduce the channel access latency. However, maintaining high reliability needs progressively channel resources, such as consistency, diversity redundancy, and retransmission, while extending latency over URLLC applications requirements of less than 1 *ms*. The authors propose a novel RA enhancement in [100], including parallel RA preambles, dynamic, reserved RA preambles, and enhanced back-off mechanisms to diminish the channel collision probability. Arouk *et al.* [101] developed an analytical method to model RACH procedure output in mMTC networks, which is also a promising 5G NR network. Their proposed model is essentially used with any system to manage congestion that affects ACBs. In [102], the authors recommend avoiding the RACH cycle without needing network synchronization to achieve smooth mobility. Their proposed generalized RACH-less handover scheme reduces the latency considerably. Choi [103] proposes an adaptive selection mechanism for RA preamble pool size by modeling the RACH procedure using the quick retrieval method [104]. The work in [105] presents a stochastic mathematical model based on geometry for evaluating the potential of the RACH method. This study reports for network scale, characteristics of network radio services, power control used, network interference. Reddy *et al.* [106] suggests a RACH-based protocol for successive interference cancelation (SIC), which results in a higher RACH success rate for mMTC networks. The authors in [107] propose a distributed queueing-based contention resolution (DQ-based CR) mechanism for the RACH procedure, in particular for mMTC networks. Their proposed approach uses MAC layer network estimation techniques to reduce the delay in network access and energy consumption considerably. Researchers have recently concentrated on applying ML techniques to improve the RACH procedure in LTE/5G networks. Bello *et al.* [108], [109] proposes a frame ALOHA for Q learning-based RACH procedure (FA-QL-RACH) which uses the Q learning (QL) model to perform a collision-free RACH procedure for machine-to-machine (M2M) networks. Their proposed FA-QL-RACH mechanism significantly improves the performance of the network in terms of both throughput and reliability. This work was extended in their later work [110] by the same authors, where authors propose to use a new

back-off algorithm for the RACH procedure. QL is viewed as being able to be used effectively for M2M data traffic, dramatically improving the channel resources' throughput efficiency. Their proposed system dynamically adapts back-off times to allow further improvements compared to a fixed-back-off scheme. Table VI summarizes main characteristics of the RACH-related research contributions.

C. DOWNLINK/UPLINK SCHEDULING

In 5G networks, DL/UL resources scheduling is the responsibility of the gNB MAC layer. Such scheduling of resources can for throughput maximization, channel access fairness among the UEs, and achieving QoS requirements. The motivation of which carrier to give priority relies upon the QoS requirements of the applications in use, which are grouped as QoS class identifier (QCI) [111]. The QCI groups determine deferral periods, retry limits, QoS priority levels (High, medium, and low), and whether the carrier requires a guaranteed data-rate. The 5G MAC layer strategies for QCI class determination is specified in [112].

DL schedulers in 5G systems can be of three types; QoS-aware scheduling, not QoS-aware scheduling, and channel-aware scheduling. RBs are generally designed for UE dependent on metrics of requirements which are evaluated for each bearer for each TTI. Distribution is made of the resources contenders with the highest metric estimate for an RB. In the case of channel-aware scheduling, the RBs are allocated to the bearer experiencing good channel conditions for the RBs at present. QoS-aware scheduling conveys further points of contention, because one bearer has priority over others. We are excited about QoS-aware scheduling for URLLC requirements in 5G systems because of its guaranteed latency, which can also be like channel-aware scheduling to offer enhanced reliability. Non-QoS-aware scheduling models, however, implement the scheduling of blind equivalent throughput (BET), maximum throughput (MT), and proportional fair (PF) scheduling. The BET scheduler expects to give all UEs reasonableness by equalizing their exponentially weighted moving average (EWMA) throughput fairly. The MT scheduler, on the other hand, improves the overall network throughput by giving priority to bearers with the most anticipated data-rate. The PF scheduler, on the other hand, consolidates the BET and MT schedulers with the objective of maximizing total network throughput with achieving equity. In order to inform gNB of the quality of UL channel resources, each UE transmits its resources through its bearer, where the gNB controls the resources distributed to each UE. As shown in Figure 7, a radio resource control (RRC) layer specifies a prioritized bit rate (PBR) for each QoS-based channel [113] above the MAC layer. Few of the RLC layer features are shown in the figure, such as upper layer PDU transfers, HARQ error correction etc. In each TTI, a variable is increased by $TTI \times PBR$, which is the calculation of the information to be transmitted in order to remain aware of the PBR. This variable will become < 0 , which is negative when sending information ahead of the PBR. Nevertheless,

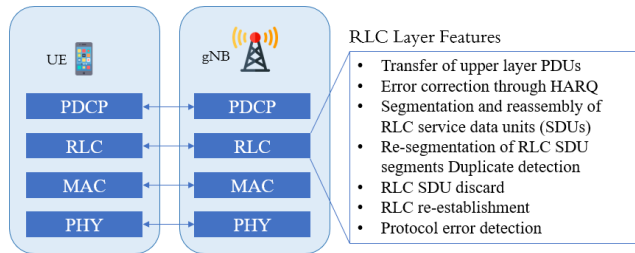

FIGURE 7. The role of RLC layer in the user plane protocol stack.

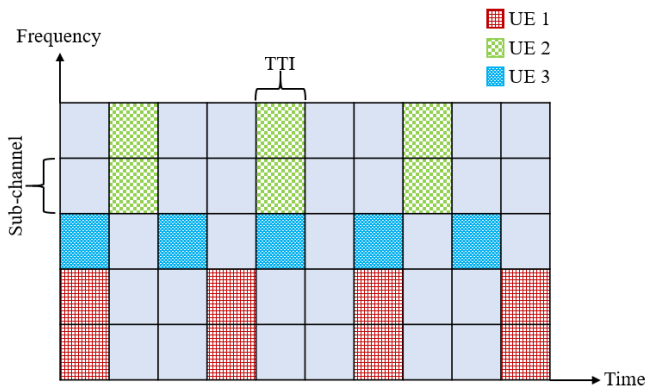

FIGURE 8. One of the examples of PS/SP scheduling allocation technique.

the channel services are assigned to logical channels with this variable's positive value depending on the order of the QoS priority. Upon every assignment of channel resource the variable is decremented. As such, if appropriate channel resources are allocated to satisfy a high QoS priority bearer, the UE allocation process first fulfills the requirements of the high QoS priority bearer, as is necessary for URLLC requirements [113].

Although dynamic FDMA techniques have the basic benefit of leveraging multi-user channel gain, this comes at the cost of increased overhead control messages due to the need to send control messages to the already scheduled UEs per TTI. Especially in high-traffic situations, therefore, the limited channel resources devoted to controlling message transmission become a bottleneck, with subsequent deterioration of QoS-based priority capability [114]. To tackle this problem, [115] has explored on persistent/semi-persistent scheduling (PS/SPS) techniques. Jiang *et al.* [116] defined that control overhead messages are used in the PS / SPS techniques to pre-allocate some RBs to a UE over a given time, identifying active/inactive periods. According to these techniques, if a gNB notifies a UE on the PS allocation, the interested UE will already know the specific TTI/RB groups to receive PDSCH data packets, or for the UL scheduling, it will transmit PUSCH data packets without any additional PDCCH overhead. In Figure 8, a graphical PS/SPS demonstration is given. In the figure, one of the examples shows that UE 1 has resources allocated after three TTIs, and UE 2 has resources,

consistently on a similar sub-channel, after every five TTIs. A major problem with PS/SPS methodology is that promoting the HARQ process does not seem acceptable. In practice, a single data packet requires the effective transmission of several data packets, where the expected number of retransmission differs in the network for each UE which depends on many factors. For example, the quality of the channels, the versatility of the UE and the apparent intercell interference.

Related Contributions

The role of DL/UL scheduling in the LTE/5G networks has been continuously studied by researchers. A detailed survey on DL/UL scheduling techniques is presented by the authors of [117] and [118]. Many approaches for expanding scheduling strategies have been proposed in the literature. In [119], the PF approach was outlined as an optimization of scheduling methods, with the goal of optimizing the achieved throughput within the traditional limitations of the LTE/5G networks. Their results indicated that the performance acquired with the unpredictability of the optimization problem by using various increments of PF implementations. However, this efficiency is achieved at the cost of increased computational complexity, which also makes it difficult for the individual networks to grasp a given algorithm. The solution to generalized proportional fair (GPF) is introduced in [120]. The PF metric in this analysis is generalized via two novel parameters. The function of those two parameters is to alter the effect of the immediate data rate and past achieved throughput, respectively, on the allocation strategy. Likewise, Proebster *et al.* [121] and Li *et al.* [122] use adaptive schemes designed to change the level of fairness that can be accomplished, depending on the network conditions. The reduced latency is seen in different papers, using PS/SPS. Such as Hoymann *et al.* [123] shows that for LTE Release 14 settings, faster UL resource scheduling using PS/SPS will reduce UL transmission latency from 12.5 ms to 7.5 ms. Authors discuss PS/SPS in an industrial context in [124] and show that PS/SPS decreases latency to less than half that of dynamic scheduling. In [124], the instant UL access (IUA) is also defined as a low latency portion for intermittent and delay sensitive data traffic. A UE currently sends a MAC PDU in response to an assigned dynamic UL channel resource or configured PS/SPS request, irrespective of whether there is no data packet for [125] transmission. Theoretically, the IUA is the same as PS/SPS, in that periodic channel resources are often allocated, although the resources are not supposed to be used. The requirements of the URLLC are thus met at the cost of the potentially high spectral inefficiency. In Table VII, we summarize some of the relevant contributions discussed for DL/UL scheduling techniques under this section.

IV. UNLICENSED SPECTRUM TECHNOLOGIES FOR URLLC REQUIREMENTS

In Section 2.C, we have already described the 5G NR-based unlicensed access and their coexistence issues and challenges with existing unlicensed ISM technologies, such

TABLE 7. Summary of contributions related to DL/UL scheduling techniques.

Reference	Proposed mechanism	Key features
Kwan <i>et al.</i> [119]	Optimization of Scheduling methods	<ul style="list-style-type: none"> • Optimization for maximization of achieved throughput under the typical limitations of an LTE/5G networks. • Performance acquired by utilizing various PF implementations. • Performance is achieved at the expense of an increased computational complexity.
Wengerter <i>et al.</i> [120]	Generalized Proportional Fair (GPF)	<ul style="list-style-type: none"> • The PF metric is generalized by means of two novel parameters. • The role of those two parameters is to alter the effect on the allocation strategy of the immediate data rate and of the past accomplished throughput, respectively.
Proebster <i>et al.</i> [121] and Li <i>et al.</i> [122]	Adaptive tuning of feasible fairness level	<ul style="list-style-type: none"> • Utilizes adaptive schemes equipped for tuning the feasible fairness level, subject to the network conditions.
Hoymann <i>et al.</i> [123]	Faster UL resource scheduling	<ul style="list-style-type: none"> • Utilizes PS/SPS, to reduce UL transmission latency from 12.5ms to 7.5ms for LTE Release 14 settings.
Ashraf <i>et al.</i> [124]	Instant UL Access (IUA)	<ul style="list-style-type: none"> • Explores PS/SPS in an industrial domain • Exhibits that PS/SPS decreases latency to less than half that of dynamic scheduling.

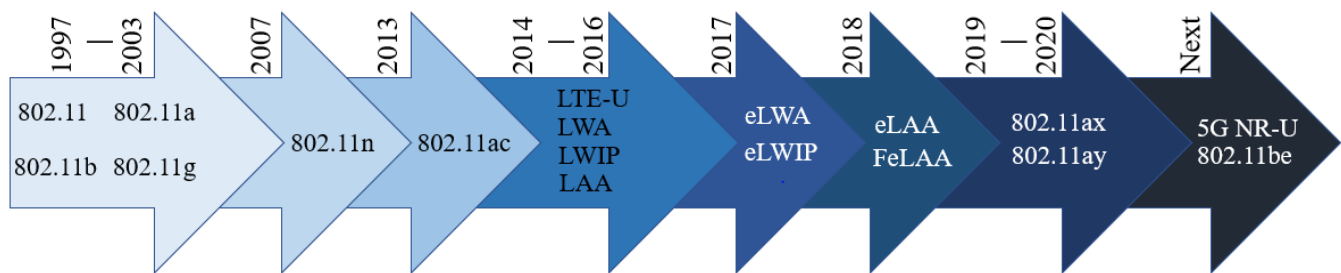

FIGURE 9. Timeline of unlicensed spectrum technologies along with LTE/5G licensed spectrum.

as Wi-Fi. However, there exist several 5G use cases that require the help of a variety of unlicensed radio spectrum technologies like Wi-Fi. For ultra-dense UE deployments, unlicensed spectrum technologies combined with LTE/5G networks enhance the network capacity and benefit UEs' network resources experience. The role of Wi-Fi as a fundamental part of 5G NR URLLC requirements is driven by new technologies and considered as one of the incumbent technology, for example, IEEE 802.11ax [15] (also known as high efficiency WLAN (HEW)), IEEE 802.11ay-Based mmWave WLANs [126], and time-sensitive networking (TSN) in IEEE 802.11be [127] [128]. Figure 9 illustrates the standardization timeline of technologies that use unlicensed spectrum technologies.

Futuristic 5G, also referred to as beyond 5G (B5G), networks are promising to cooperate with next generation WLANs (that is HEW), as their incumbent technologies to provide one of the inspiring services, such as URLLC and astonishingly high throughput services. The amalgamation of HEW networks with 5G communication systems has been a topic of

interest for researchers over the past two decades. According to an online report [129], over 70% of the mobile data traffic is generated by the WLAN networks. Given the favorable economics and high performance of WLANs, it will remain a very attractive choice for indoor and enterprise applications. While cellular has its origins outdoors, we expect HEW and 5G/B5G to co-exist both indoors and outdoors. IEEE working group (WG) has recently launched an amendment to IEEE 802.11 WLANs, named as IEEE 802.11ax HEW. HEW deals with massively connected device deployment scenarios. One of the sectors of the international telecommunication union (ITU), known as ITU-Radiocommunication (ITU-R) [130], has been specifying requirements of 5G/B5G and HEW, which potentially satisfy URLLC requirements [131]. It is anticipated that HEW infers the exciting features of both; the devices' environment as well as devices' interacting behavior with its environment to spontaneously manage the channel resource allocation parameters at the MAC layer. Practically, a HEW device, also referred as a station (STA) proficiently and dynamically manages the wireless channel

resources, for example, the MAC layer's distributed coordination function (DCF) which utilizes a carrier sense multiple access with collision avoidance (CSMA/CA) mechanism to resolve collision issues in the network. In general, STAs' performance relies upon the exploitation of the uncertainty of the system heterogeneity in terms of transmitted data variety. Therefore, to accomplish the targeted objectives of HEW for URLLC requirements in 5G NR, it is imperative to examine effective and robust resource allocation schemes.

A. IEEE 802.11AX HIGH EFFICIENCY WLAN (HEW)

IEEE 802.11 working group (WG) [132] created the 11ax task group (TG) [133] in 2013, known as HEW with the objective of upgrading the PHY and MAC layers of already implemented IEEE 802.11 networks to improve unlicensed spectrum usage effectiveness in dense user deployment scenarios [15]. For this purpose, the HEW underpins both DL and UL multiuser (MU) transmissions dependent on OFDMA and MIMO [134], called MU-MIMO, increasing channel widths up to 160 MHz, and spatial reuse techniques based on adaptively adjusting the transmit power level and sensitivity threshold.

The ideal increment of the user throughput is accomplished by increasingly effective spectrum utilization. One of the key features of HEW is the adoption of an OFDMA approach, which is a methodology broadly utilized in LTE/5G systems, however very new to the WLANs. This feature allows HEW to group together adjacent sub-carriers into a single resource unit (RU). Thus sender can pick the best RU for every specific receiver, which results in higher signal-to-interference-in addition to noise ratio (SINR), modulation, and coding scheme (MCS) and throughput. Besides, carrier aggregation has also made compulsory for a shorter size of messages to reduce the channel access time [15]. As indicated by the most recent TGax specification, OFDMA allows a six times higher throughput than legacy 802.11 [135]. Thus, the OFDMA technique makes WLAN wireless channel access nearer to the LTE or cellular systems. However, as opposed to LTE, OFDMA in HEW systems works on top of the DCF-based MAC layer mechanisms and requires AP coordination. Whereas, In LTE, OFDMA is time sensitive, i.e., different carriers correspond to various UEs during a single TTI. In HEW systems, OFDMA is based on a transmission time frame, in which sending/receiving data packets from various devices and different carriers are allocated to the devices for the whole time frame.

Performance Improvements

HEW allows an STA for UL MU transmission just after finishing its DL MU transmission, which is obviously a useful technique to send an ACK frame simultaneously. This improvement is achieved by including a trigger frame (TF) in DL MU transmission to reserve the UL RU transmission slot. In addition, it also solicits a UL MU transmission by including request data in the MAC layer header of DL PPDU. Likewise, a HEW access point (AP) acknowledges

for UL MU transmission by transmitting ACKs in the MAC header of DL PPDU [134]. Along with this, HEW also cascades MU transmissions by alternating DL MU and UL MU transmissions within a TXOP. This allows a HEW AP to exchange data frames in a single MU transmission with various HEW STAs [133]. One of the critical challenges is that a DL/UL MU transmission must be aligned in the time domain. Therefore, if a HEW STA transmits a short data frame, it either uses padding of the information or aggregates the information with another data frame. However, when there is not much space left during the aggregation process, only padding can be performed [136]. A HEW device fragments the data frames to avoid wasting channel resources in order to overcome the extra gaps within the payloads [137]. Also, performance can be further improved if data frames from different access categories (ACs) can be aggregated [138]. However, the aggregation of various fragments is a complex mechanism, HEW compromises by defining several optional levels of data frame fragmentation. In the first level, only one fragment without aggregation is permitted to send. Later the second level permits a HEW STA to aggregate only one fragment per MSDU. Whereas, in the third level, the aggregation of two or more fragments per MSDU is allowed [139].

Related Contributions

Ghosh, *et al.* [140] proposed a TF for random access (TF-R) by including at least one resource allocation for a single RU, which is randomly accessed by several HEW STAs within the network. In TF-R, a HEW STA decodes the TF-R to detect the identifiers and allocated RUs. However, since the random access is similar to the traditional slotted Aloha, a high probability of collision may occur. A sub-channel level carrier sensing (CS) is proposed in [141]. The authors present a multi-channel CSMA/CA (MC-CSMA/CA) based on non-triggered frame transmission, that is a HEW STA can transmit its data frame without any TF by the HEW AP. The main difference between a TF-based and non-TF-based UL MU transmission is that in the case of non-TF-based UL MU transmission, there exists a sparsity in the channel due to distributed access. It reduces the normalized throughput of the systems, especially for unsaturated traffic conditions. Whereas, this is not the issue with a TF-based UL MU transmission, as the HEW AP adjusts the frequency of the TF schedules to match the offered network load, which allows fair access to the resources. To overcome the negative impact of distributed channel access in HEW networks, the target wake up time (TWT) mechanism introduced in the IEEE 802.11ax amendment can play a significant role because it gives simple and effective procedure to schedule DL/UL MU transmissions in time [142]. Lanante *et al.* [143] proposed a hybrid UL OFDMA random access (H-UORA) channel access mechanism, which reduces the channel collision with the help of carrier sensing capabilities. In their proposed H-UORA, a secondary back-off for multi-carrier CSMA/CA is embedded. However, ever increasing number of contenders

TABLE 8. Summary of contributions related to IEEE 802.11ax HEW MAC-RA techniques.

Reference	Proposed mechanism	Key features
Ghosh <i>et al.</i> [140]	TF-R	<ul style="list-style-type: none"> • TF for random access (TF-R) by including at least one resource allocation for a single RU • However, since the random access is similar to the traditional slotted Aloha, a high probability of collision may occur
Kwon <i>et al.</i> [141]	MC-CSMA/CA	<ul style="list-style-type: none"> • A multi-channel CSMA/CA (MC-CSMA/CA) based on non-triggered frame transmission, that is a HEW STA can transmit its data frame without any TF by the HEW AP
Nurchis <i>et al.</i> [142]	Discussed the applications of TWT	<ul style="list-style-type: none"> • TWT can help to take full benefits of novel procedures in the HEW, such as DL/UL MU transmissions, spatial reuse, and coexistence in densely deployed WLANs • TWT can be a step forward towards a practical collision-free and deterministic channel access in future WLANs for 5G NR technologies
Lanante <i>et al.</i> [143]	H-UORA	<ul style="list-style-type: none"> • A hybrid UL OFDMA random access (H-UORA) channel access mechanism to reduce the channel collision with the help of carrier sensing capabilities
Shahin <i>et al.</i> [144]	CB	<ul style="list-style-type: none"> • A Cognitive Back-off mechanism to adaptively scale contention window of the STAs • Efficient collision avoidance with higher throughput and lower channel access delay
Ali <i>et al.</i> [145]	COSB	<ul style="list-style-type: none"> • Channel observation-based scaled backoff mechanism • Determines channel collision probability after observing back-off idle and busy slots • scales-up and scales-down contention window based on the observed channel collision probability
Ali <i>et al.</i> [146]	<i>i</i> QRA	<ul style="list-style-type: none"> • <i>intelligent</i> QL-based MAC layer resource allocation mechanism • Resolve the channel collision using QL techniques • The <i>i</i>QRA mechanism learns diverse HEW environments and optimizes the network performance, compared to conventional MAC protocols

in densely deployed WLAN networks opens more and more challenges for the collision resolution mechanisms. For this purpose, Shahin *et al.* [144] proposes a cognitive back-off (CB) mechanism, which adaptively scales contention parameters of a HEW STA to provide efficient MAC-RA in densely deployed networks. Their proposed CB mechanism enhances the network throughput and reduces the delay for both dense as well as sparse network situations. A more enhanced version of CB was proposed in [145], where authors observed the channel to determine collision probability. In [145], authors propose a channel observation-based scaled back-off (COSB) mechanism. The COSB scaled contention window size based on observed channel collision probability, which performs efficiently for dense HEW environments. Later, Ali *et al.* [146] proposed an *intelligent* Q-learning-based MAC layer resource allocation (*i*QRA) mechanism to enhanced the performance of COSB. The use of QL algorithm in MAC protocol proven that ML-based MAC protocols learn the diverse WLAN environments and optimize the network performance. In Table VIII, we summarize a few of the

related contributions discussed in this section.

B. IEEE 802.11BE EXTREMELY HIGH THROUGHPUT (EHT)

The recently released IEEE 802.11ax HEW tends to focus on the user performance and experience in the densely deployed WLAN environments more. Where meeting the low latency requirements of next-generation technologies like 5G NR is beyond the capabilities of HEW. Therefore, IEEE WG is interested in releasing a new amendment to meet these new needs and challenges, named as IEEE 802.11be extremely high throughput (EHT) [58]. IEEE 802.11be is also known as Wi-Fi 7, which is beyond the IEEE 802.11ax HEW standard. IEEE WG has established an IEEE 802.11be TG in MAY 2019 and specified the scope of next-generation Wif-Fi with introducing new PHY layer and MAC layer resource allocation modes to achieve maximum per user throughout of at least 30 Gbps in 1-7.250 GHz carrier frequencies [147]. To achieve these goals, few of the enhanced PHY/MAC layer technologies have been identified as enabling solutions. In

HEW, each HEW STA is only allowed to access a specific RU for UL/DL transmission, which significantly affects the resource scheduling flexibility. EHT solves this problem and further enhances the spectrum efficiency by allowing multiple RUs to a single EHT STA [148]. However, due to the early stages of EHT, most of the related technical details are still in progress, including multiple RU assignments. In the following subsection, we specifically focus on a few of the performance enhancements related to the WLAN MAC protocol for EHT. Please refer to a recently published survey and tutorial on the topic of IEEE 802.11be EHT [128] for a detailed discussion on PHY/MAC layer enhancements and designs.

Performance Improvements

Among several other improvements to currently implemented HEW, few of the well-known enhancements are; multi-link operation over increased bandwidth, support of increased spatial streams and enhanced MIMO, distributed coordination among the APs, enhanced link adaptation, and improved retransmission mechanism.

The currently implemented HEW suffers QoS challenges for serving advanced applications like augmented reality (AR) due to limited and overcrowded 2.4 GHz and 5 GHz unlicensed spectra. EHT proposes to expand its bandwidth using multi-operation aggregation over 2.4 GHz and 5 GHz to gain new 320 MHz bandwidth. However, the issues and challenges of frequency selection for much broader and non-adjacent bandwidth, various multi-operations, and backward coexistence arise with the use of multi-operation aggregation. Likewise, the massively increased demand for heterogeneous traffic by the increased connected WLAN STAs is fulfilled by increasing the number of MIMO antennas and enhanced spatial multiplexing capabilities at the APs. Currently, a HEW AP equipped with eight antennas can simultaneously support up to eight HEW STAs for UL/DL transmissions using MU-MIMO. Whereas, EHT expecting to support maximum spatial streams of up to 16 to achieve higher WLAN capacity. However, an increase in the number of antennas for an increased number of spatial streams brings an auxiliary rise in the channel state information (CSI) overheads. Therefore, EHT also requires to improve existing explicit and implicit CSI feedback mechanisms to reduce the induced overheads. Another vital improvement in EHT is the use of distributed coordination operations among the WLAN APs. HEW only supports coordination and spatial reuse between HEW STAs and HEW APs without considering neighboring APs, which significantly reduces the capability to utilize the flexibility of time, frequency, and spatial resources of the WLAN. EHT improves the WLAN capability by proposing coordination among the neighboring APs. This is one of the major performance improvement features of EHT as compared to HEW and traditional WLANs [128], [149], known as multi-AP coordination. Similarly, for the transmission reliability, EHT expects to include HARQ to enable additional parity at the receiver to improved link adaptation and retransmission

mechanisms. However, the implementation of HARQ in WLAN systems is challenging due to retransmission granularity, for example, aggregate MPDU (A-MPDU) and incremental redundancy (IR). Therefore, EHT must carefully decide the operating layer and the changes required for the implementation of HARQ in WLAN systems.

Related Contributions

The traditional MAC protocols have limitations that an MSDU belongs to a single transmission identity (TID), which uses a single channel and resulting in a significant increase of overheads. In [150], the authors propose a notable MAC protocol improvement, named as a unified MAC (U-MAC) protocol for multi-link operations, to eliminate the need for multiple data plane renegotiation overheads. Their proposed U-MAC protocol contains only one MAC sub-layer management entity and one MAC sub-layer, which supports most of the MAC layer operations, such as A-MSDU aggregation, data frame sequencing, encryption/decryption, integrity, and fragmentation/fragmentation [151]. Currently, IEEE 802.11 protocols an STA obtains its TXOP using primary channel (PCH). Thus spectral resources are utilized ineffectively if congestion occurs due to densely deployed WLANs. A temporary primary channel (T-PCH) is introduced in the secondary channels to enhance the channel usability if the primary channel is unavailable [152]. In this proposed method, a device may start the CSMA/CA process on the T-PCH as well as on the PCH, and it can obtain a TXOP on either of the channels. This way, a WLAN STA obtains more TXOPs for the transmissions. However, the presence of T-PCH strongly depends upon the status of the PCH, and such MAC-RA dramatically limits the spectrum usage due to wastage of idle channels. Lu *et al.* [153] proposed an optimized multiple PCH (OM-PCH) MAC layer channel access mechanism to satisfy various transmission needs for different services. In OM-PCH, an AP simultaneously operates two channel access mechanisms on two different channels, named as a contention-free module and a contention-based module. The contention-free module is responsible for MSDU transmission from time-critical applications with scheduled TXOPs on multi-links, and the contention-based module is responsible for MSDU transmission from non time-critical applications with the help of CSMA/CA on multi-links. In Table IX, we summarize a few of the related contributions discussed in this section for IEEE 802.11be EHT MAC-RA techniques.

V. FEDERATED REINFORCEMENT LEARNING TECHNIQUES IN WIRELESS COMMUNICATION SYSTEMS

This section briefly describes the potentials of FRL techniques for current and upcoming wireless technologies like 5G/B5G. We also include related contributions from the research community, focusing on the implementation of FRL-based techniques for 5G networks. This section is essential because, later, based on this section, we propose several

TABLE 9. Summary of contributions related to IEEE 802.11be EHT MAC-RA techniques.

Reference	Proposed mechanism	Key features
Fang <i>et al.</i> [150]	U-MAC	<ul style="list-style-type: none"> Unified MAC (U-MAC) protocol for multi-link operations Eliminates the need multiple data plane renegotiation overheads
Ahn <i>et al.</i> [152]	T-PCH	<ul style="list-style-type: none"> A temporary primary channel (T-PCH) is introduced in the secondary channels to enhance the channel usability if the primary channel is unavailable A WLAN STA may start CSMA/CA process on the T-PCH as well as on the PCH A WLAN STA obtains more TXOPs for the transmissions
Lu <i>et al.</i> [153]	OM-PCH	<ul style="list-style-type: none"> An optimized multiple PCH (OM-PCH) MAC layer channel access mechanism to satisfy various transmission needs for different services An AP simultaneously operates two channel access mechanisms on two different channels, named as a contention-free module (for time-critical applications) and contention-based module (for non time-critical applications)

potential research opportunities for 5G NR URLLC requirements.

A. FEDERATED REINFORCEMENT LEARNING

FRL, also referred to as a collaborative ML technique, is one of the distributed setups of the RL technique that learns the environment across numerous decentralized devices without sharing their actual data. FRL differs from the traditional centralized ML techniques, where all the target data is needed to be uploaded to a single server. In addition, FRL empowers numerous learning devices to construct a typical, strong ML model without sharing the actual data/information. FRL allows each learner/agent (such as a WLAN STA) to work on a set of local learning parameters, referred to as the local learning model (LLM). In FRL, instead of sharing the entire training data-set, an agent shares its LM with its neighbor or central entity (such as a WLAN AP). The central device performs its learning algorithms upon the received LM of the agent and shares the results with all other learners in the environment, referred to as the global learning model (GLM). As a decentralized ML technique, FRL tends to address the security and privacy concerns by disseminating the information to distributed agents in the environment. The applications of FRL are already recognized by several research areas of next-generation technologies, such as 5G/B5G, IoT and Blockchain networks [154]–[159]. Figure 10 presents a very generalized FRL framework in an unlicensed WLAN environment. In the figure, a WLAN STA observes the surrounding environment to generate it LM. Later the LM values are collaborated with the centralized WLAN AP to construct a GM value. A WLAN AP sends its determined GM value to all the WLAN STAs within the environment. This collaborative learning of the WLAN environment increases the optimization capabilities of each individual learner.

An FRL-based framework works in three phases. Firstly, a

device in the environment computes its value function (such as Q-value in a typical RL model) from locally available information, known as LLM. Later in the second phase, it shares its LLM value with the centralized WLAN AP to determine a global value, which is GLM. Finally, in the last phase of the FRL, a WLAN STA updates the FRL model based on both the LLM value (locally computed) and GLM value (globally computed), as shown in Figure 10.

B. CONTRIBUTIONS FOR WIRELESS COMMUNICATION SYSTEMS

Recently, several researchers from institutions, as well as from the industry, have started working for the implementation of FL techniques in wireless communication systems. In this subsection, we briefly highlight some of the contributions made by the researcher for the role of FL techniques in wireless communication systems.

Ye *et al.* [160] used a distributed deep RL (DRL) framework for sub-band and power resource allocation issues in 5G-based vehicle-to-vehicle (V2V) communication systems. In their proposed framework, each V2V link is considered as an agent making decision based on its own locally computed optimal values to reduce interference under latency constraints. Konecny *et al.* [161] used federated learning (FL) in a distributed learning environment for task scheduling in wireless networks, named as multi-task learning (MTL). In [162], the authors propose a distributed FL model for vehicular user equipment (VUE) using maximum likelihood estimation (MLE). However, this work lacks the ability to share wireless resources for distributed FL and V2V networks. Thus the impact of distributed FL model for collaborated resource allocation on URLLC requirements is not investigated. Therefore, in their later work [163], authors proposed another distributed FL-based framework for URLLC communication based on the joint transmit power MAC-RA framework. The authors address a network-wide energy minimization issue while en-

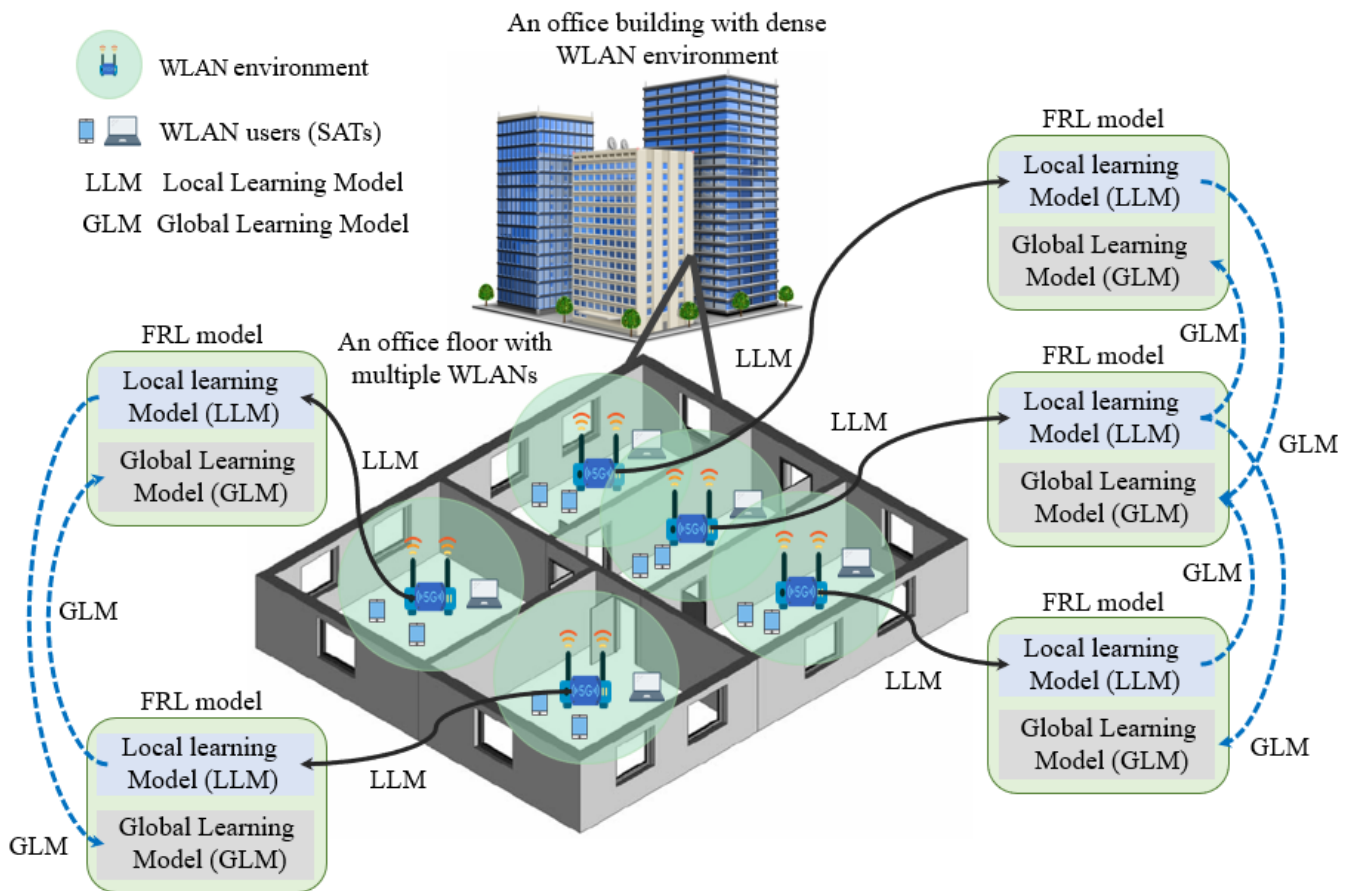

FIGURE 10. A typical office floor with multiple WLANs as a specific scenario of Federated Reinforcement Learning-based WLAN environment.

asuring URLLC services in terms of probabilistic queue sizes. McMahan *et al.* [164] proposes a practical mechanism for the FL composed of DRL based on iterative average model (IAM), named as FederatedAveraging algorithm. In the FederatedAveraging mechanism, wireless communication costs are the major constraint. Thus it shows reduced communication handshakes as compared to synchronized stochastic mechanisms. In [165], authors studied the impact of both interference and imperfect channel state information (CSI) in wireless communication systems using federated learning techniques, named as coded federated computing (CFC). In CFC, Ha *et al.* [165] use an information-theoretic approach based on communication delay to investigate URLLS requirements. Habachi *et al.* [166] investigated the MAC-RA problems in NOMA for mMTC and proposed three novel frameworks; fast MTC allocation, massive MTC allocation, and QoS-aware MTC allocation. The authors concluded that the use of distributed FL techniques for MTC services allows us to design efficient MAC-RA schemes for NOMA-based wireless communication systems. In an FL-based MTC framework, the centralized model is trained distributively over a massive number of connected wireless sensors. LLM is updated on the users' side and communicated the model

update to the centralized BS to obtain GLM updates. In this way, the centralized BS efficiently allocates RUs and power levels to the end users. Zhu *et al.* [167] proposed a federated edge learning (FEEL) framework-based *broadband analog aggregation* (BBA) mechanism to address the issues of privacy, network congestion, and URLLC services due to massive real-time data upload to the cloud for inference purposes. Their proposed mechanism aggregates LLM determined on UEs to update GLM at the BS. It perceives the operation over the broadband multi-access radio spectrum by exploiting simultaneous transmissions. Isaksson *et al.* [168] proposed a multi-parity computation-based (MPC) FL framework, which aggregates distributed FL updates in a privacy preservation manner based on MPC. MPC-based FL scheme is a privacy preservation mechanism for distributed FL techniques in 5G communication systems. The authors evaluated their proposed scheme based on communication cost, storage expenses, and computational complexity. Mowla *et al.* [169] proposed an adaptive FRL (AFRL) mechanism for optimized jamming security in flying ad-hoc networks (FANET). AFRL uses a model-free QL algorithm with an adaptive exploration and exploitation method, known as ϵ -greedy policy, directed by an LLM for jamming detection. The LLM value computed

by an on-device detection mechanism is transmitted to a multi-access edge server for the determination of the GLM value, which is later downloaded by the flying drone to detect a jamming attack.

C. FEDERATED REINFORCEMENT LEARNING FOR URLLC

To provide URLLC services, we may use FRL since it does not need labeled training data like supervised learning. When using RL for URLLC, the value matrix may have a broad dimension, making conventional Q-learning algorithms take a long time to evolve, mainly when the state space is continuous. In these situations, collaborative learning techniques such as FRL can be used to estimate the Q-function [170]. The Q-value for a given state and behavior can be calculated from the FRL model output. A collaborated value function can also be used to estimate the optimum policy that maps the state of the system to the operation if the FRL policy is deterministic. For example, the authors in [171] investigated the inter-slice resource management problem in network slicing, where a neural network approximates the resource management strategy. As a result, without making any assumptions about the users' environment, a model-free FRL-based resource management system will balance the tradeoff between reliability, latency, and data rate. An FRL-based architecture that distributively estimates the users' data traffic model and then uses that optimal behavior to collaboratively delegate RBUs and power to DL users for URLLC constraints [172].

Furthermore, when using FRL in URLLC, a few problems remain undefined, such as the expectation of a formulated MDP. It is well understood that FRL can only be used to find optimum MDP control policies to begin. However, problems in practical systems may not be Markovian. Secondly, unlike optimization problems with restrictions to ensure QoS conditions, FRL does not have any constraints. While we may design specific heuristic incentives and punishments that take QoS into account, it is unclear if the obtained QoS can meet URLLC's requirements [171]. Furthermore, to increase the FRL's results, the algorithm must investigate any unknown acts that could result in unintended incentives or punishments.

VI. POTENTIAL RESEARCH OPPORTUNITIES

We started this paper with a brief introduction of 5G NR and its PHY/MAC layer characteristics for URLLC requirements. Throughout the article, one of our main focus was to develop an understanding of the importance of the MAC protocols of unlicensed spectrum technologies to achieve 5G NR URLLC requirements. With this aim, we explored two of the most recent and upcoming WLAN technologies, that is HEW and EHT, which are assumed to be incumbent technologies for futuristic 5G NR. We also explored the role of FL and FRL to enhance the performance of wireless communication networks to achieve URLLC requirements. So far, we learned that next-generation communication systems are all about

the integration of ML techniques in all most every part of the communication networks. Based on these observations, we present a few of the potential research opportunities for FRL-based mechanisms. Figure 11 articulates potential applications of the FRL-based framework for 5G/B5G communication systems.

A. FRL-BASED MAC-RA MECHANISM

One of the recently proposed MAC-RA mechanism, *i*QRA [147], optimizes contention parameters of the STA based on their individually estimated Q-value. However, a QL algorithm may perform unwell in numerous dynamic and stochastic WLAN environments, mainly due to substantial overestimation of locally determined Q-values in QL algorithm. Therefore, to cure this issue, we propose to use the FRL-based *i*QRA (*Fi*QRA) mechanism. *Fi*QRA mechanism allows WLAN STAs to share and collaborate their locally estimated LLM information with the centralized WLAN AP. In the *Fi*QRA mechanism, an STA competing for the channel resources can learn the WLAN environment faster than an STA in *i*QRA mechanism, because *Fi*QRA can optimize the MAC-RA contention parameters based on the federated GLM information from the WLAN AP. *Fi*QRA assumes a WLAN AP as a GLM learner of the WLAN environment, and WLAN STAs around the AP as its LLM learners to update local learning. In this LLM, an STA senses the channel for observation-based collision probability as formulated by the *i*QRA mechanism. In *i*QRA mechanism, the competing STAs perform a BEB procedure for channel resources with the selection of a random back-off value after the channel is sensed idle for a distributed interframe space (DIFS) period. The discretized time slots during the BEB procedure are observed as either idle or busy by the STA. A WLAN STA formulates channel collision probability based on the observed idle and busy slots. The formulated collision probability works as a reward for the WLAN STA to accumulate its Q-value function. Since individual estimated Q-value may suffer from large overestimation (due to error variances), in the proposed *Fi*QRA mechanism, every STA integrates its LLM updated value, in the acknowledgment (ACK) packet, known as federated ACK (FACK) message to collaborate with WLAN AP. This federated LLM Q-value provides a second Q-value function for the GLM accumulator at the WLAN AP. Since *Fi*QRA updates the GLM Q-value based on federated LLM Q-value in the same WLAN environment, but with a different set of observations, thus it represents a fair estimate for the Q-value of this action. For the *Fi*QRA mechanism, both Q-value functions (LLM and GLM) must learn from separate sets of experiences in the same environment. Thus, a WLAN STA uses both Q-value functions to update its optimal Q-value estimate, which has the chance of lower error variance as compared to the non-federated *i*QRA mechanism.

TABLE 10. Summary of contributions related to Federated Reinforcement Learning-based techniques for wireless communication systems.

Reference	Proposed mechanism	Key features
Ye <i>et al.</i> [160]	Distributed DRL	<ul style="list-style-type: none"> A distributed DRL framework for resources allocation in 5G-based vehicle-to-vehicle (V2V) communication systems Locally computed LLM value is collaborated among the neighbours
Konecny <i>et al.</i> [161]	MTL	<ul style="list-style-type: none"> A distributed FL environment for task scheduling in wireless networks, named as multi-task learning
Samarakoon <i>et al.</i> [162]	MLE-based distributed FL	<ul style="list-style-type: none"> A distributed FL model for vehicular user equipment (VUE) using maximum likelihood estimation (MLE)
Samarakoon <i>et al.</i> [163]	GPD-based distributed FL	<ul style="list-style-type: none"> Distributed FL-based framework for URLLC communication based on joint transmit power MAC-RA framework A network-wide energy minimization issue while ensuring URLLC services in terms of probabilistic queue sizes The generalized pareto distribution (GPD) is used to obtain the statistics of the queue lengths of VUEs
McMahan <i>et al.</i> [164]	FederatedAveraging	<ul style="list-style-type: none"> A practical DRL-based FL mechanism on iterative average model FederatedAveraging shows reduced communication handshakes as compared to synchronized stochastic mechanisms
Ha <i>et al.</i> [165]	CFC	<ul style="list-style-type: none"> The impact of both interference and imperfect channel state information (CSI) in wireless communication systems using federated learning techniques Coded federated computing (CFC) uses an information-theoretic approach based on communication delay to investigate URLLC requirements
Habachi <i>et al.</i> [166]	Fast mMTC, massive mMTC, QoS-aware mMTC	<ul style="list-style-type: none"> Investigated the MAC-RA problems in NOMA for mMTC and proposed three novel frameworks The use of distributed FL techniques for MTC services allows to design efficient MAC-RA schemes for NOMA-based wireless communication systems
Zhu <i>et al.</i> [167]	FEEL-based BAA	<ul style="list-style-type: none"> A federated edge learning (FEEL) framework-based <i>broadband analog aggregation</i> (BBA) mechanism A mechanism to address the issues of privacy, network congestion, and URLLC services due to massive real-time data upload to the cloud for inference purposes It aggregates LLM determined on UEs to update GLM at the BS. It perceives the operation over the broadband multi-access radio spectrum by exploiting simultaneous transmissions
Isaksson <i>et al.</i> [168]	MPC-based FL	<ul style="list-style-type: none"> Aggregation of distributed FL updates in a privacy preservation manner based on multi-parity computation (MPC) A privacy preservation mechanism for distributed FL techniques in 5G communication systems Evaluated based on communication cost, storage expenses and computational complexity
Mowla <i>et al.</i> [169]	AFRL	<ul style="list-style-type: none"> Adaptive Federated Reinforcement Learning (AFRL) mechanism for optimized jamming security for flying ad-hoc networks AFRL uses a model-free QL algorithm with an adaptive exploration and exploitation method, known as ϵ-greedy policy LLM value computed by an on-device detection mechanism is transmitted to a multi-access edge server for the determination of the GLM value

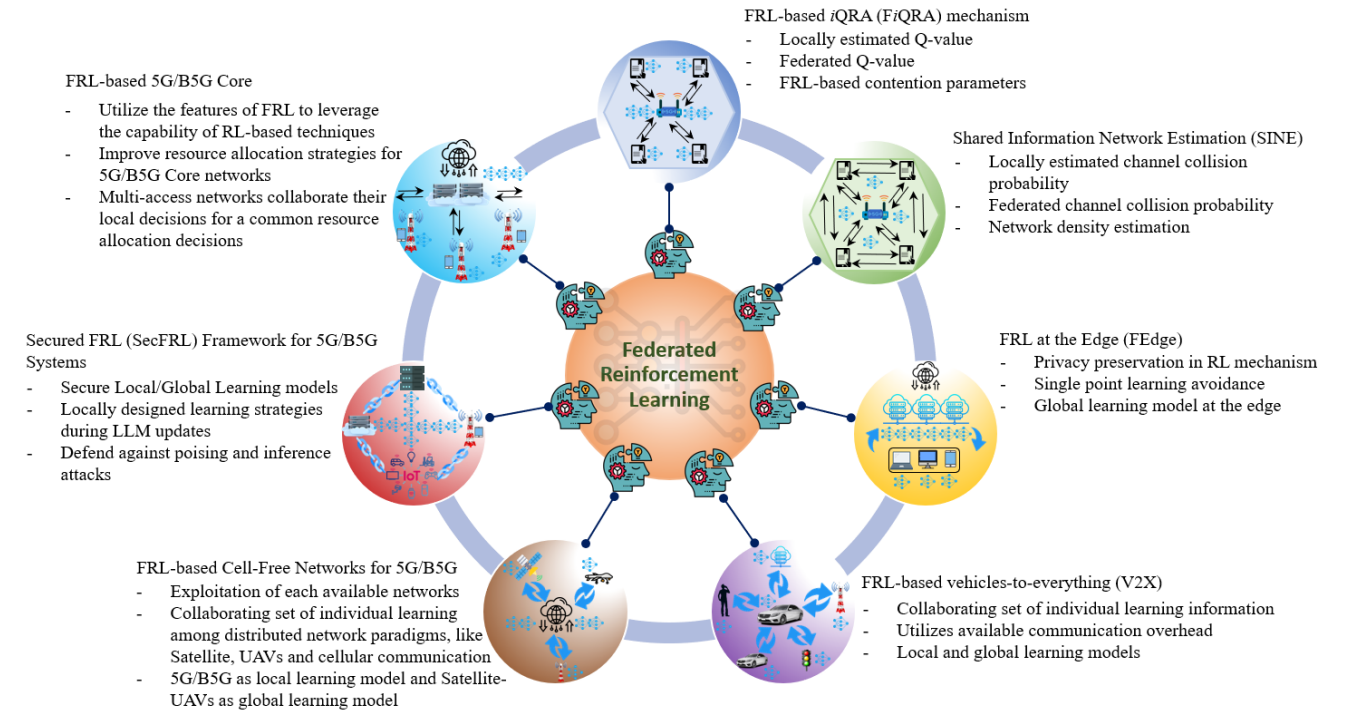

FIGURE 11. Potential FRL-based frameworks for 5G/B5G communication networks.

B. SHARED INFORMATION NETWORK ESTIMATION (SINE) METHOD

The performance of a massive WLAN environment strongly relies upon the number of contending STAs, which is the enormous number of connoted devices that are simultaneously trying to access channel resources. However, the information on the number of WLAN STAs competing for the channel resources cannot be retrieved even in the presence of a WLAN AP due to a limited number of associated WLAN STAs (which is usually different than the actual active STAs in the WLAN environment). The ability to estimate the actual number of connected WLAN STAs induces numerous implications in a WLAN environment. In [173], the authors indicate that the MAC-RA contention parameters like CW depend upon the number of contending WLAN STAs to maximize the WLAN system performance. However, in a distributed WLAN environment, the accuracy of the individually estimated number of devices degrades with the increase of the number of WLAN STAs due to the amplified errors in the collision probability [173]. Moreover, due to the non-linear relation between the estimated number of WLAN STAs and channel collision probability, the individual estimation is unfair. Therefore, we propose to utilize the FRL-based shared information network estimation (SINE) method for such a WLAN environment with massively connected devices. In the proposed SINE method, a WLAN STA can use the FACK messages to collaborate its estimated LLM value with the neighboring WLAN STAs. Based on the collaborated LLM value, each WLAN STA can formulate its GLM value. Further, the CW of an STA can be resized based

on the estimated GLM value.

C. FRL AT THE EDGE (FEDGE)

Recently, edge computing (EC) has increased significant enthusiasm due to its capacity to broaden cloud computing efficiencies to the wireless network edge with URLLC requirements. Various futuristic 5G NR applications, such as autonomous driving cars, augmented reality (AR), remote surveillance, and TI with low latency, utilize features of EC. In such applications, the connected edge user devices have rigorous computational resource constraints. One approach to furnish those edge devices with on-demand computing resources is to utilize a cloud network. However, the characteristic deferral relating to end-to-end communications with a cloud server can prompt to intolerable latency. Conventional RL-based frameworks, such as proposed in [174], [175] uses centralized or individual learning data, which requires transferring of information from numerous geographically distributed devices to the learning device. However, the dynamic and varying EC environment for 5G NR communication systems makes the MAC-RA a non-convex optimization process composed of a complex objective function and constraints, which are more complicated to solve. Therefore, It is crucial to introduce collaborated, and edge deployed RL techniques such as FRL to cope with the challenges of environment data privacy preservation and URLLC requirements in RL mechanisms for EC systems. It is essential to utilize FRL at the edge (FEdge) to empower different insightful applications with URLLC requirements. FRL enables data privacy preservation in the network by avoiding the use of centralized

or single point learning. FEdge involves a set of wireless devices within its environment and computation of the global learning model at the edge of the network.

D. FRL-BASED VEHICLE-TO-EVERYTHING (V2X) COMMUNICATIONS

In 5G/B5G networks, Vehicle-to-everything (V2X) communication is a key enabler for self-driving autonomous cars. Besides, V2X communication assists in expanding the effectiveness of transportation frameworks employing collaborative task handling. However, the performance of autonomous services in a self-driving car, such as instant navigation, collision evasion, and collaborative task handling, significantly depends on the capacity to communicate based on URLLC requirements, because the target E2E latency for URLLC requirement is of $< 1ms$. To achieve this targeted latency requirement, most of the existing related work focuses on improving the expected latency of a V2X network by utilizing a probabilistic control to sustain queuing delays at the end devices utilizing DRL techniques [176]. However, a DRL-based probabilistic control approach may improve network reliability on shorter queue length devices but fails to control the exceptional actions of large queue length devices with low channel access probability. Therefore, few of the end devices (vehicles) in the V2X network may encounter volatile latency, causing network performance degradation. The major issue with the use of probabilistic methods is due to the lack of enough information samples of rare extraordinary events.

In V2X communication, road-side units (RSU) can aid vehicles to gather numerous information samples over the network at the cost of additional communication overheads. As we mentioned earlier, FRL permits learning models by collaborating a set of LLM information with other devices within the environment using available communication overheads (such as the use of FACK messages). Besides, the FRL framework does not depend on synchronization among other devices in a V2X network due to locally implemented DRL algorithm. Thus, even if connectivity between vehicle and RSU fails, a vehicle can, in any case, learn and explore the environment with the help of locally available LLM information.

E. SECURE FRL (SEC-FRL) FRAMEWORK FOR 5G/B5G SYSTEMS

Data security and privacy preservation are some of the major challenges while fulfilling URLLC requirements of 5G/B5G communication systems. For this purpose, attention to focus on addressing the performance and efficiency challenges of existing ML techniques is required. However, traditional ML techniques need a certain amount of private information to be analyzed at the central device where ML model training of the data is performed [177]. Such a training procedure at the centralized server may cause potential security threats and privacy leakages for 5G/B5G network UEs. Several researchers have already proposed FL-based mechanisms to

address these challenges, such as [178]–[180] and [181]. These authors focused on the use of collaborative distributed ML models like FL for mobile devices. Although the use of FL models for wireless communication enables new application scenarios, for example, EC and SDN, for the UEs in 5G networks, yet faces two critical challenges related to security; poisoning and user inference attack [181]. A brutal security attack may cause a failure in GLM update of the FL model, and also in case of user inference attack, rich semantic data may breach from intermediate gradients. Such a vulnerability brings the need to propose a more secure and trustworthy model for the use of FL techniques, where LLM/GLM updates can be utilized more securely. Therefore, the use of FRL is proposed to defend against poisoning and inference attacks. The FRL model uses value-based LLM training models in an automated and anonymous manner for each device (that is a UE) in the 5G/B5G system environment. The LLM provides robust defensive measures against user inference attacks using locally designed learning strategies during the LLM updates. Based on the proposed SecFRL framework, a central device (that is a BS) creates a decentralized and trustless data store to eliminate the impact of dependence on agents in the conventional FL model.

F. FRL-BASED 5G/B5G CORE

One of the demanding network services by 5G NR for URLLC requirements is a fundamental change to the 5G Core (5G-C) architecture. A 5G-C is the heart of the network and plays the role of the anchor point for multi RATs in the network, which needs to deliver a seamless service experience across the network. 3GPP [10] defines a new 5G-C architecture to support service delivery over wired/fixed network, wireless networks, and converged access networks. The 5G-C with strategically located servers at the edges and cloud-lets is recognized as the critical underlying part for the support of 5G NR URLLC requirements other TI applications [182]. For the performance enhancement of existing deployed converged access networks to support URLLC requirements, effective network control, and resource management mechanisms are required. RL has already been considered as one of the promising solutions to achieve intelligent and optimized network control and resource allocation. Numerous researchers [183]–[185] have proposed uses of RL techniques for optimal decision making, routing, and link selection. However, the major issue with RL-based techniques is that every RL-enabled device must learn the optimal decision with the help of exploration. Thus as a trade-off, an optimal action is approached at the expense of excessive time in performing sub-optimal actions. The selection of sub-optimal actions during the exploration could negatively affect overall performance. Therefore, it is proposed to utilize the features of FRL to leverage the capability of RL-based techniques in improving resource allocation strategies for 5G-C networks, whilst at the same time achieving URLLC services through FL techniques. In the proposed FRL-based 5G-C, multi-access networks collaborate their LLM-based

decisions for a common (GLM-based) resource allocation decisions. Multiple networks share their individual exploration to speed up the learning of an optimal strategy, hence, benefiting all the participating converged networks.

G. FRL-BASED CELL-FREE NETWORKS FOR 5G/B5G

It is critical to take advantage of the unique benefits of each available networking paradigm to accommodate the diverse 5G/B5G applications with different URLLC requirements in various practical scenarios [186]. For example, heterogeneous terrestrial networks in city environments provide high data rate access. The satellite systems offer broad coverage and improved integration to the most isolated and lightly populated areas. Similarly, the unmanned aerial vehicle (UAV) networks aid existing cellular networks for fast service recovery and traffic offloading of the extremely crowded areas in a cost-effective fashion [187]. The authors in [188], mainly addressed the cell-free on-demand coverage issues to overcome the cost-ineffectiveness of conventional cellular architecture, like 4G and earlier. The authors also implemented opportunistic spectrum sharing to cope with the spectrum scarcity problem. Currently, it is commonly accepted that individual networks would not be able to satisfy the need for processing massive amounts of data and executing large-scale systems such as IoT, cloud storage, and big data. As a result, there is an increasing demand among scientific communities to create an interconnected network infrastructure to provide cell-free communications using space-based, air-based, and ground-based networks. The use of multiple network and communication technologies enables the need for more sophisticated and distributed ML techniques. For this purpose, we propose the implementation of FRL-based cell-free networks for 5G/B5G systems where 5G/B5G systems can serve as an LLM and Satellite-UAVs as GLM for distributed and collaborated learning.

VII. CONCLUSION

In this survey paper, we have comprehensively summarized the researches related to the advancement of the 5G/B5G communication systems, especially focusing on the concept of 5G NR and URLLC requirements. This survey briefly covers the research in PHY layer, MAC layer resource allocation, PHY-MAC cross-layer MAC-RA mechanisms, and the implications of one of the recently emerged ML techniques, that is, FRL in wireless communication systems. Major performance improvements and related research contributions are identified for most of the sections in this survey. In addition, we list recent research contributions related to the role of FL/FRL techniques in 5G/B5G networks. Although extensive surveys and tutorials have been published related to the 5G NR and URLLC requirements, there still lacks a comprehensive discussion on the topics, such as TI, PHY layer, MAC-RA, FL/FRL, and URLLC requirements. Furthermore, FRL techniques for URLLC requirements need to be explored in the future. With the discussion on the use of FL/FRL for the performance improvement of wireless communication networks,

we come to the conclusion that FRL-based techniques are more robust and efficient for 5G systems as compared to the conventional ML-based algorithms. FRL-based frameworks for next generation 5G networks are required to handle MAC-RA mechanisms, network estimation, edge computing and caching services, vehicular networks, security issues in 5G networks, and even converged networks in the core. Therefore, in this survey, we presented seven very important and critical FRL-based potential research directions for 5G/B5G network environment for URLLC requirements. These potential research directions are named as FRL-based MAC-RA mechanism, shared information network estimation (SINE), FRL at the Edge (FEdge), FRL-based Vehicle-to-everything (V2X) communications, Secure FRL (SecFRL) framework for 5G/B5G systems, FRL-based 5G/B5G Core, and FRL-based cell-free networks for 5G/B5G systems.

With the advent of the B5G communication system, we believe that the use of FRL will gain more and more attention from the researchers. We hope that this survey will set out useful guidelines for interested researchers from institutions as well as industry to have a comprehensive understanding and implications of FRL techniques in 5G/B5G systems for URLLC.

ACKNOWLEDGMENT

R. Ali and Y. B. Zikria have contributed equally as First Author.

This work was supported by the National Research Foundation of Korea(NRF) grant funded by the Korea government (MSIT) (No.2019R1A4A1023746, No. 2019R1F1A1060799)

REFERENCES

- [1] M. Maier and A. Ebrahimzadeh, "Towards immersive tactile Internet experiences: Low-latency FiWi enhanced mobile networks with edge intelligence [Invited]," in *IEEE/OSA Journal of Optical Communications and Networking*, vol. 11, no. 4, pp. B10-B25, April 2019. doi:10.1364/JOCN.11.000B10
- [2] C. Li et al., "5G-Based Systems Design for Tactile Internet," in *Proceedings of the IEEE*, vol. 107, no. 2, pp. 307-324, Feb. 2019. doi: 10.1109/JPROC.2018.2864984
- [3] H. S. Varsha and K. P. Shashikala, "The tactile Internet," 2017 International Conference on Innovative Mechanisms for Industry Applications (ICIMIA), Bangalore, 2017, pp. 419-422. doi: 10.1109/ICIMIA.2017.7975649
- [4] G. P. Fettweis, "The Tactile Internet: Applications and Challenges," in *IEEE Vehicular Technology Magazine*, vol. 9, no. 1, pp. 64-70, March 2014. doi: 10.1109/MVT.2013.2295069
- [5] The Tactile Internet, ITU-T Technology Watch Report, ITU-T, Geneva, Switzerland, 2014.
- [6] S. Tanwar, S. Tyagi, I. Budhiraja and N. Kumar, "Tactile Internet for Autonomous Vehicles: Latency and Reliability Analysis," in *IEEE Wireless Communications*, vol. 26, no. 4, pp. 66-72, August 2019. doi: 10.1109/MWC.2019.1800553
- [7] I. Budhiraja, S. Tyagi, S. Tanwar, N. Kumar and J. J. P. C. Rodrigues, "Tactile Internet for Smart Communities in 5G: An Insight for NOMA-Based Solutions," in *IEEE Transactions on Industrial Informatics*, vol. 15, no. 5, pp. 3104-3112, May 2019. doi: 10.1109/TII.2019.2892763
- [8] M. Simsek, A. Aijaz, M. Dohler, J. Sachs and G. Fettweis, "5G-Enabled Tactile Internet," in *IEEE Journal on Selected Areas in Communications*, vol. 34, no. 3, pp. 460-473, March 2016. doi: 10.1109/JSAC.2016.2525398
- [9] A. Aijaz, M. Dohler, A. H. Aghvami, V. Friderikos and M. Frodigh, "Realizing the Tactile Internet: Haptic Communications over Next Generation 5G Cellular Networks," in *IEEE Wireless Communications*, vol. 24, no. 2, pp. 82-89, April 2017. doi: 10.1109/MWC.2016.1500157RP

- [10] "Study on scenarios and requirements for next generation access technologies (release 14), V14.2.0," 3GPP, Sophia Antipolis, France, Rep. TR 38.913, Mar. 2017.
- [11] 3GPP TR 38.912, TSG RAN; Study on New Radio (NR) access technology, Release 14, v14.0.0, Mar. 2017.
- [12] N. Patriciello, S. Lagen, L. Giupponi and B. Bojovic, "5G New Radio Numerologies and their Impact on the End-To-End Latency," 2018 IEEE 23rd International Workshop on Computer Aided Modeling and Design of Communication Links and Networks (CAMAD), Barcelona, 2018, pp. 1-6. doi: 10.1109/CAMAD.2018.8514979
- [13] J. Sachs et al., "5G radio network design for ultra-reliable low-latency communication," IEEE Netw., vol. 32, no. 2, pp. 24–31, Mar./Apr. 2018.
- [14] 3GPP TS 38.300, NR; Overall description; Stage-2, Release 15, v15.1.0, Apr. 2018.
- [15] R. Ali, S. W. Kim, B. Kim, and Y. Park, "Design of MAC layer resource allocation schemes for IEEE 802.11ax: Future directions," IETE Technical Review, vol. 35(1), pp. 28-52, February 2018.
- [16] J.M. Romano and K. J. Kuchenbecker, "Creating realistic virtual textures from contact acceleration data," IEEE Trans. Haptics, vol. 5, no. 2, pp. 109–119, Apr./Jun. 2012.
- [17] H. Culbertson, J. Unwin, and K. J. Kuchenbecker, "Modeling and rendering realistic textures from unconstrained tool-surface interactions," IEEE Trans. Haptics, vol. 7, no. 3, pp. 381–393, Jul./Sep. 2014.
- [18] K. M. Stanney, R. S. Kennedy, and K. Kingdon, Virtual Environment Usage Protocols. Boca Raton, FL, USA: CRC Press, 2002
- [19] O. N. C. Yilmaz, Y.-P. E. Wang, N. A. Johansson, N. Brahma, S. A. Ashraf, and J. Sachs, "Analysis of ultra-reliable and low-latency 5G communication for a factory automation use case," in Proc. IEEE Int. Conf. Commun. (ICC), London, U.K., Jun. 2015, pp. 1190–1195.
- [20] F. Boccardi, R. W. Heath, A. Lozano, T. L. Marzetta, and P. Popovski, "Five Disruptive Technology Directions for 5G," IEEE Communications Magazine, vol. 52, no. 2, pp. 74–80, 2014.
- [21] 3GPP TS 21.916, NR; Release description; Release 16, v0.1.0, Sep. 2019.
- [22] B. Soret, P. Mogensen, K. I. Pedersen, and M. C. Aguayo-Torres, "Fundamental tradeoffs among reliability, latency and throughput in cellular networks," in Proc. IEEE Globecom Workshops (GC Wkshps), Dec. 2014, pp. 1391–1396.
- [23] P. Popovski, "Ultra-reliable communication in 5G wireless systems," in Proc. 1st Int. Conf. 5G Ubiquitous Connectivity, Dec. 2014, pp. 146–151.
- [24] E. G. Ström, P. Popovski, and J. Sachs, "5G ultra-reliable vehicular communication," Mathematics, vol. 14, pp. 204–217, Oct. 2015.
- [25] 3GPP TR 38.824, Study on physical layer enhancements for NR ultra-reliable and low latency case (URLLC), Rel-17 Stage 1, RAN#88, June 2020.
- [26] J. Sachs et al., "Adaptive 5G Low-Latency Communication for Tactile Internet Services," in Proceedings of the IEEE, vol. 107, no. 2, pp. 325-349, Feb. 2019. doi: 10.1109/JPROC.2018.2864587
- [27] J. Vihriälä et al., "Numerology and frame structure for 5G radio access," in Proc. 27th IEEE Annu. Int. Symp. Pers., Indoor, Mobile Radio Commun. (PIMRC), Valencia, Spain, Sep. 2016, pp. 1–5.
- [28] C. Hoymann et al., "LTE release 14 outlook," IEEE Commun. Mag., vol. 54, no. 6, pp. 44–49, Jun. 2016.
- [29] O. Teyeb, G. Wikström, M. Stattin, T. Cheng, S. Faxér, and H. Do, "Evolving LTE to fit the 5G future," Ericsson Technol. Rev., no. 2, 2017.
- [30] N. Ye et al., "Uplink non-orthogonal multiple access technologies toward 5G: A survey," Wireless Commun. Mob. Comput., vol. 2018, Jun. 2018, Art. no. 6187580.
- [31] G. Ma et al., "Coded tandem spreading multiple access for massive machine-type communications," IEEE Wireless Commun., vol. 25, no. 2, pp. 75–81, Apr. 2018.
- [32] Y. Du et al., "Efficient multi-user detection for uplink grant-free NOMA: Prior-information aided adaptive compressive sensing perspective," IEEE J. Sel. Areas Commun., vol. 35, no. 12, pp. 2812–2828, Dec. 2017.
- [33] G. J. Sutton et al., "Enabling Technologies for Ultra-Reliable and Low Latency Communications: From PHY and MAC Layer Perspectives," in IEEE Communications Surveys & Tutorials, vol. 21, no. 3, pp. 2488-2524, third quarter 2019. doi: 10.1109/COMST.2019.2897800
- [34] Y. Niu, Y. Li, D. Jin, L. Su, and A. V. Vasilakos, "A survey of millimeter wave communications (mmWave) for 5G: Opportunities and challenges," Wireless Netw., vol. 21, no. 8, pp. 2657–2676, 2015.
- [35] A. Nasrallah et al., "Ultra-Low Latency (ULL) Networks: The IEEE TSN and IETF DetNet Standards and Related 5G ULL Research," in IEEE Communications Surveys & Tutorials, vol. 21, no. 1, pp. 88-145, First quarter 2019. doi: 10.1109/COMST.2018.2869350
- [36] L. Tian, C. Yan, W. Li, Z. Yuan, W. Cao and Y. Yuan, "On uplink non-orthogonal multiple access for 5g: opportunities and challenges," in China Communications, vol. 14, no. 12, pp. 142-152, December 2017. doi: 10.1109/CC.2017.8246331
- [37] N. Ye, H. Han, L. Zhao, and A. Wang, "Uplink Nonorthogonal Multiple Access Technologies Toward 5G: A Survey," Wireless Communications and Mobile Computing, vol. 2018, Article ID 6187580, pp. 1-26. doi: 10.1155/2018/6187580
- [38] L. Dai, B. Wang, Y. Yuan, S. Han, C. I and Z. Wang, "Non-orthogonal multiple access for 5G: solutions, challenges, opportunities, and future research trends," in IEEE Communications Magazine, vol. 53, no. 9, pp. 74-81, September 2015. doi: 10.1109/MCOM.2015.7263349
- [39] K. I. Pedersen, G. Berardinelli, F. Frederiksen, P. Mogensen, and A. Szufarska, "A flexible 5G frame structure design for frequency division duplex cases," IEEE Commun. Mag., vol. 54, no. 3, pp. 53–59, Mar. 2016. doi: 10.1109/MCOM.2016.7432148
- [40] B. Farhang-Boroujeny and H. Moradi, "OFDM Inspired Waveforms for 5G," in IEEE Communications Surveys & Tutorials, vol. 18, no. 4, pp. 2474-2492, Fourth quarter 2016. doi: 10.1109/COMST.2016.2565566
- [41] M. S. Elbambly, C. Perfecto, M. Bennis and K. Doppler, "Toward Low-Latency and Ultra-Reliable Virtual Reality," in IEEE Network, vol. 32, no. 2, pp. 78-84, March-April 2018. doi: 10.1109/MNET.2018.1700268
- [42] H. Chen et al., "Ultra-Reliable Low Latency Cellular Networks: Use Cases, Challenges and Approaches," in IEEE Communications Magazine, vol. 56, no. 12, pp. 119-125, December 2018. doi: 10.1109/MCOM.2018.1701178
- [43] M. Suer, C. Thein, H. Tchouankem and L. Wolf, "Multi-Connectivity as an Enabler for Reliable Low Latency Communications -An Overview," in IEEE Communications Surveys & Tutorials. doi: 10.1109/COMST.2019.2949750
- [44] I. Althamary, C. Huang and P. Lin, "A Survey on Multi-Agent Reinforcement Learning Methods for Vehicular Networks," 2019 15th International Wireless Communications & Mobile Computing Conference (IWCMC), Tangier, Morocco, 2019, pp. 1154-1159. doi: 10.1109/IWCMC.2019.8766739
- [45] S. K. Sharma and X. Wang, "Towards Massive Machine Type Communications in Ultra-Dense Cellular IoT Networks: Current Issues and Machine Learning-Assisted Solutions," in IEEE Communications Surveys & Tutorials. doi: 10.1109/COMST.2019.2916177
- [46] X. Jiang et al., "Low-Latency Networking: Where Latency Lurks and How to Tame It," in Proceedings of the IEEE, vol. 107, no. 2, pp. 280-306, Feb. 2019. doi: 10.1109/JPROC.2018.2863960
- [47] M. Polese, M. Giordani, and M. Zorzi, "3GPP NR: the standard for 5G cellular networks," in 5G Italy White eBook: from Research to Market, 2018.
- [48] M. Series, "IMT vision: Framework and overall objectives of the future development of IMT for 2020 and beyond," Recommendation IT U-R, Rep. M. 2083-0, 2015.
- [49] S. Lagen, B. Bojovic, S. Goyal, L. Giupponi, and J. Manges-Bafalluy, "Subband Configuration Optimization for Multiplexing of Numerologies in 5G TDD New Radio," IEEE Int. Symp. on Personal, Indoor and Mobile Radio Commun., Sep. 2018.
- [50] S. Parkvall, E. Dahlman, A. Furuskar, and M. Frenne, "Nr: The new 5g radio access technology," IEEE Communications Standards Magazine, vol. 1, pp. 24–30, Dec 2017.
- [51] M. Giordani, M. Polese, A. Roy, D. Castor, and M. Zorzi, "A tutorial on beam management for 3gpp nr at mmwave frequencies," IEEE Communications Surveys & Tutorials, vol. 21, pp. 173–196, First quarter 2019.
- [52] M. Labib, "Extending LTE into the unlicensed spectrum: technical analysis of the proposed variants," IEEE Communications Standards Magazine, vol. 1, pp. 31–39, Dec. 2017.
- [53] R. Bajracharya, R. Shrestha, R. Ali, A. Musaddiq, and S. W. Kim, "LWA in 5G: State-of-the-art architecture, opportunities, and research challenges," IEEE Communications Magazine, vol. 56(10), pp. 134-141, October 2018
- [54] R. Ali, N. Shahin, A. Musaddiq, B. Kim and S. W. Kim, "Fair and Efficient Channel Observation-Based Listen-Before Talk (CoLBT) for LAA-WiFi Coexistence in Unlicensed LTE," 2018 Tenth International Conference on Ubiquitous and Future Networks (ICUFN), Prague, 2018, pp. 154-158. doi: 10.1109/ICUFN.2018.8436776
- [55] RP-170828, 3GPP TSG RAN 75 Meeting, Study on NR-based Access to Unlicensed Spectrum, Mar. 2017.
- [56] RP-190706, 3GPP TSG RAN 83 Meeting, Revised WID on NR-based Access to Unlicensed Spectrum, Mar. 2019

- [57] M. X. Gong, B. Hart, and S. Mao, "Advanced Wireless LAN Technologies: IEEE 802.11ac and Beyond," *GetMobile*, Vol. 18, no. 4, pp. 48–52, Jan. 2015.
- [58] D. Lopez-Perez, A. Garcia-Rodriguez, L. Galati-Giordano, M. Kasslin and K. Doppler, "IEEE 802.11be Extremely High Throughput: The Next Generation of Wi-Fi Technology Beyond 802.11ax," in *IEEE Communications Magazine*, vol. 57, no. 9, pp. 113–119, September 2019. doi: 10.1109/MCOM.001.1900338
- [59] IEEE 802.11ad Specific requirements. Part 11: Wireless LAN Medium Access Control. Available at: <http://standards.ieee.org/findstds/standard/802.11ad-2012.html>.
- [60] T. Nitsche, C. Cordeiro, A. B. Flores, E. W. Knightly, E. Perahia, and J. C. Widmer, "IEEE 802.11ad: directional 60 ghz communication for multi-gigabit-per-second wi-fi [invited paper]," *IEEE Communications Magazine*, vol. 52, pp. 132–141, December 2014.
- [61] Y. Ghasempour, C. R. C. M. da Silva, C. Cordeiro, and E. W. Knightly, "IEEE 802.11ay: Next-generation 60 ghz communication for 100 gb/s wi-fi," *IEEE Communications Magazine*, vol. 55, pp. 186–192, Dec 2017.
- [62] J. Jeon, H. Niu, Q. Li, A. Papathanassiou and G. Wu, "LTE with listen-before-talk in unlicensed spectrum," 2015 IEEE International Conference on Communication Workshop (ICCW), London, 2015, pp. 2320–2324. doi: 10.1109/ICCW.2015.7247527
- [63] H. Hu, Y. Gao, J. Zhang, X. Chu, Q. Chen and J. Zhang, "Density Analysis of LTE-LAA Networks Coexisting With WiFi Sharing Multiple Unlicensed Channels," in *IEEE Access*, vol. 7, pp. 148004–148018, 2019. doi: 10.1109/ACCESS.2019.2946604
- [64] H. Zhang, "Coexistence of Wi-Fi and heterogeneous small cell networks sharing unlicensed spectrum," *IEEE Communications Magazine*, vol. 53, pp. 158–164, Mar. 2015.
- [65] R. Zhang, M. Wang, L. X. Cai, Z. Zheng, X. Shen, and L. Xie, "LTE unlicensed: the future of spectrum aggregation for cellular networks," *IEEE Wireless Communications*, vol. 22, pp. 150–159, June 2015.
- [66] A. P. Subramanian and S. R. Das, "Addressing deafness and hidden terminal problem in directional antenna based wireless multi-hop networks," *Springer Journal Wireless Networks*, vol. 16, pp. 1557–1567, Sep. 2008.
- [67] LTE-U Forum, LTE-U Technical Report, Coexistence study for LTE-U SDSL V1.0, Feb. 2015.
- [68] L. Laselv et al., "3GPP LTE-WLAN Aggregation Technologies: Functionalities and Performance Comparison," *IEEE Communications Magazine*, vol. 56, no. 3, Mar. 2018, pp. 195–203.
- [69] 3GPP TS 36.300, "Evolved Universal Terrestrial Radio Access (E-UTRA) and Evolved Universal Terrestrial Radio Access Network (E-UTRAN); Overall Description; Stage 2," V.13.3.0, 2017; <https://www.3gpp.org>, accessed May 18, 2018.
- [70] 3GPP TR 36.889, Study on Licensed Assisted Access to Unlicensed Spectrum (Release 13), V13.0.0, June 2015.
- [71] RP-152272, 3GPP TSG RAN 70 Meeting, New Work Item on enhanced LAA for LTE (Release 14), May 2015.
- [72] RP-170848, 3GPP TSG RAN 75 Meeting, New Work Item on enhancements to LTE operation in unlicensed spectrum (Release 15), Mar. 2017.
- [73] G. Berardinelli, S. R. Khosravirad, K. I. Pedersen, F. Frederiksen and P. Mogensen, "Enabling Early HARQ Feedback in 5G Networks," 2016 IEEE 83rd Vehicular Technology Conference (VTC Spring), Nanjing, 2016, pp. 1–5. doi: 10.1109/VTCspring.2016.7504213
- [74] B. Bertenyi et al., "5G NR Radio Interface," *Journal of ICT Standardization*, vol. 6, issue 1&2, May 2018, pp. 31–58.
- [75] M. Serror, C. Dombrowski, K. Wehrle, and J. Gross, "Channel coding versus cooperative ARQ: Reducing outage probability in ultra-low latency wireless communications," in *Proc. IEEE Globecom Workshops (GC Wkshps)*, San Diego, CA, USA, Dec. 2015, pp. 1–6.
- [76] H. Shariatmadari, S. Iradj, and R. Jäntti, "Analysis of transmission methods for ultra-reliable communications," 2015 IEEE 26th Annual International Symposium on Personal, Indoor, and Mobile Radio Communications (PIMRC), Hong Kong, 2015, pp. 2303–2308. doi: 10.1109/PIMRC.2015.7343682
- [77] Qualcomm, 3GPP R1-1721515, 3GPP TSG RAN WG1 91 Meeting, Summary of DL/UL scheduling and HARQ management, Dec. 2017.
- [78] P. Marsch et al., "Emerging network architecture and functional design considerations for 5G radio access," *Transactions on Emerging Telecommunication Technologies*, vol. 27, no. 9, pp. 1168–1177, 2016. doi: 10.1002/ett.3073.
- [79] Y. Gao, T. Yang and B. Hu, "Improving the transmission reliability in smart factory through spatial diversity with ARQ," 2016 IEEE/CIC International Conference on Communications in China (ICCC), Chengdu, 2016, pp. 1–5. doi: 10.1109/ICCCChina.2016.7636856
- [80] S. B. S., S. Kalyanasundaram and S. Kumar V, "A Novel HARQ Pooling Scheme for Improved Multi-Connectivity in 5G Cloud RAN," 2016 IEEE Globecom Workshops (GC Wkshps), Washington, DC, 2016, pp. 1–7. doi: 10.1109/GLOCOMW.2016.7848820
- [81] H. Shariatmadari, S. Iradj, Z. Li, M. A. Uusitalo and R. Jäntti, "Optimized transmission and resource allocation strategies for ultra-reliable communications," 2016 IEEE 27th Annual International Symposium on Personal, Indoor, and Mobile Radio Communications (PIMRC), Valencia, 2016, pp. 1–6. doi: 10.1109/PIMRC.2016.7794801
- [82] A. Avranas, M. Kountouris and R. Ciblat, "Throughput Maximization and IR-HARQ Optimization for URLLC Traffic in 5G Systems," ICC 2019 - 2019 IEEE International Conference on Communications (ICC), Shanghai, China, 2019, pp. 1–6. doi: 10.1109/ICC.2019.8761154
- [83] T. Le, U. Salim and F. Kaltenberger, "Improving Ultra-Reliable Low-Latency Communication in multiplexing with Enhanced Mobile Broadband in grant-free resources," 2019 IEEE 30th Annual International Symposium on Personal, Indoor and Mobile Radio Communications (PIMRC), Istanbul, Turkey, 2019, pp. 1–6. doi: 10.1109/PIMRC.2019.8904368
- [84] J. Yeo, J. Bang, H. Ji, Y. Kim and J. Lee, "Outer Code-Based HARQ Retransmission for Multicast/Broadcast Services in 5G," 2019 IEEE 90th Vehicular Technology Conference (VTC2019-Fall), Honolulu, HI, USA, 2019, pp. 1–5. doi: 10.1109/VTCFall.2019.8891304
- [85] T. Le, U. Salim and F. Kaltenberger, "Strategies to meet the configured repetitions in URLLC Uplink Grant-Free transmission," 2019 16th International Symposium on Wireless Communication Systems (ISWCS), Oulu, Finland, 2019, pp. 597–601. doi: 10.1109/ISWCS.2019.8877344
- [86] H. Xia, S. Han, C. Li and W. Meng, "Joint PHY/MAC Layer AN-Assisted Security Scheme in SVD-Based MIMO HARQ system," 2019 IEEE/CIC International Conference on Communications in China (ICCC), Changchun, China, 2019, pp. 328–333. doi: 10.1109/ICCCChina.2019.8855886
- [87] L. Szczecinski, S. R. Khosravirad, P. Duhamel and M. Rahman, "Rate Allocation and Adaptation for Incremental Redundancy Truncated HARQ," in *IEEE Transactions on Communications*, vol. 61, no. 6, pp. 2580–2590, June 2013. doi: 10.1109/TCOMM.2012.041113.120462
- [88] Z. Shi, T. Tsiftsis, W. Tan, G. Yang, S. Ma and M. Alouini, "Effective Capacity Analysis for VR-HARQ Systems," 2019 IEEE/CIC International Conference on Communications in China (ICCC), Changchun, China, 2019, pp. 665–670. doi: 10.1109/ICCCChina.2019.8855875
- [89] N. Strodthoff, B. Göktepe, T. Schierl, C. Helge and W. Samek, "Enhanced Machine Learning Techniques for Early HARQ Feedback Prediction in 5G," in *IEEE Journal on Selected Areas in Communications*, vol. 37, no. 11, pp. 2573–2587, Nov. 2019. doi: 10.1109/JSAC.2019.2934001
- [90] H. Chen, R. Abbas, P. Cheng, M. Shirvanimoghaddam, W. Hardjawana, W. Bao, Y. Li, and B. Vucetic, "Ultra Reliable Low Latency Cellular Networks: Use Cases, Challenges and Approaches," *IEEE Communications Magazine*, Sep. 2018.
- [91] 3GPP, "Evolved Universal Terrestrial Radio Access (EUTRA) and Evolved Universal Terrestrial Radio Access Network (EUTRAN); Overall Description," 3rd Generation Partnership Project (3GPP), TS 36.300 v.14.7.0, Jun. 2018. [Online]. Available: http://www.3gpp.org/ftp/Specs/archive/36_series/36.300/.
- [92] Hoglund, Andreas and Van, Dung Pham and Tirronen, Tuomas and Liberg, Olof and Sui, Yutao and Yavuz, Emre A, "3GPP Release 15 Early Data Transmission," *IEEE Communications Standards Magazine*, vol. 2, no. 2, pp. 90–96, Nov. 2018.
- [93] M. Condoluci, M. Dohler, G. Araniti, A. Molinaro, and J. Sachs, "Enhanced Radio Access and Data Transmission Procedures Facilitating Industry Compliant Machine Type Communications over LTE-based 5G Networks," *IEEE Wireless Communications*, vol. 23, no. 1, pp. 56–63, Mar. 2016.
- [94] Chen, Yu-Jia and Cheng, Li-Yu and Wang, Li-Chun, "Prioritized Resource Reservation for Reducing RA Delay in 5G URLLC," in *IEEE Personal Indoor and Mobile Radio Communications (PIMRC)*, Oct. 2017, pp. 1–5.
- [95] S. A. Ashraf, I. Aktas, E. Eriksson, K. W. Helmersson, and J. Ansari, "Ultra Reliable and Low Latency Communication for Wireless Factory Automation: From LTE to 5G," in *IEEE Emerging Technologies and Factory Automation (ETFA)*, 2016, pp. 1–8.
- [96] 3GPP, "RAN Improvements for Machine Type Communications," 3rd Generation Partnership Project (3GPP), TR 37.868 V11.0.0, Sep. 2011. [Online]. Available: http://www.3gpp.org/ftp/Specs/archive/37_series/37.868/

- [97] Leyva-Mayorga, Israel and Tello-Oquendo, Luis and Pla, Vicent and Martinez Bauset, Jorge and Casares-Giner, Vicente, "On the Accurate Performance Evaluation of the LTE-A RA Procedure and the Access Class Barring Scheme," in *IEEE Transactions on Wireless Communications*, vol. 16, 2017, pp. 7785–7799.
- [98] N. Jiang, Y. Deng, M. Condoluci, W. Guo, A. Nallanathan, and M. Dohler, "RACH Preamble Repetition in NB-IoT Network," *IEEE Communications Letters*, vol. 22, no. 6, pp. 1244–1247, 2018.
- [99] S. Vural, N. Wang, G. Foster, and R. Tafazolli, "Success Probability of Multiple-Preamble Based Single-Attempt Random Access to Mobile Networks," *IEEE Communications Letters*, pp. 1–5, 2017.
- [100] J. Thota and A. Aijaz, "On Performance Evaluation of Random-Access Enhancements for 5G uRLLC," 2019 IEEE Wireless Communications and Networking Conference (WCNC), Marrakesh, Morocco, 2019, pp. 1-7. doi: 10.1109/WCNC.2019.8885815
- [101] O. Arouk and A. Ksentini, "General Model for RACH Procedure Performance Analysis," in *IEEE Communications Letters*, vol. 20, no. 2, pp. 372-375, Feb. 2016. doi:10.1109/LCOMM.2015.2505280
- [102] J. Choi and D. Shin, "Generalized RACH-Less Handover for Seamless Mobility in 5G and Beyond Mobile Networks," in *IEEE Wireless Communications Letters*, vol. 8, no. 4, pp. 1264-1267, Aug. 2019. doi: 10.1109/LWC.2019.2914435
- [103] J. Choi, "On the Adaptive Determination of the Number of Preambles in RACH for MTC," in *IEEE Communications Letters*, vol. 20, no. 7, pp. 1385-1388, July 2016. doi: 10.1109/LCOMM.2016.2546238
- [104] Y.-J. Choi, S. Park, and S. Bahk, "Multichannel random access in OFDMA wireless networks," *IEEE Journal of Selected Areas in Communications*, vol. 24, no. 3, pp. 603–613, Mar. 2006.
- [105] H. G. Moussa and W. Zhuang, "RACH Performance Analysis for Large-Scale Cellular IoT Applications," in *IEEE Internet of Things Journal*, vol. 6, no. 2, pp. 3364–3372, April 2019. doi: 10.1109/IJOT.2018.2883101
- [106] Y. S. Reddy, A. Dubey and A. Kumar, "A novel RACH mechanism for machine type communications in cellular networks," 2017 IEEE International Conference on Advanced Networks and Telecommunications Systems (ANTS), Bhubaneswar, 2017, pp. 1-6. doi: 10.1109/ANTS.2017.8384154
- [107] A. H. Bui, C. T. Nguyen, T. C. Thang and A. T. Pham, "A Comprehensive Distributed Queue-Based Random Access Framework for mMTC in LTE/LTE-A Networks With Mixed-Type Traffic," in *IEEE Transactions on Vehicular Technology*, vol. 68, no. 12, pp. 12107-12120, Dec. 2019. doi:10.1109/TVT.2019.2949024
- [108] L. M. Bello, P. Mitchell, D. Grace and T. Mickus, "Q-learning Based Random Access with Collision free RACH Interactions for Cellular M2M," 2015 9th International Conference on Next Generation Mobile Applications, Services and Technologies, Cambridge, 2015, pp. 78-83. doi: 10.1109/NGMAST.2015.22
- [109] L. M. Bello, P. Mitchell and D. Grace, "Application of Q-Learning for RACH Access to Support M2M Traffic over a Cellular Network," *European Wireless 2014; 20th European Wireless Conference*, Barcelona, Spain, 2014, pp. 1-6.
- [110] L. M. Bello, P. D. Mitchell and D. Grace, "Intelligent RACH Access Techniques to Support M2M Traffic in Cellular Networks," in *IEEE Transactions on Vehicular Technology*, vol. 67, no. 9, pp. 8905-8918, Sept. 2018. doi: 10.1109/TVT.2018.2852952
- [111] Policy and Charging Control Architecture (Release 14), Version 14.3.0, 3GPP Standard TS 23.203, Mar. 2017.
- [112] Medium Access Control (MAC) Protocol Specification (Release 13), Version 13.2.0 (2016-06), 3GPP Standard TS 36.321, Jun. 2016.
- [113] 5G NR; Radio Resource Control (RRC) Protocol specification (Release 15), version 15.3.0, 3GPP TS 38.331, Oct. 2018
- [114] F. Capozzi, G. Piro, L. A. Grieco, G. Boggia, and P. Camarda, "Downlink packet scheduling in LTE cellular networks: Key design issues and a survey," *IEEE Commun. Surveys Tuts.*, vol. 15, no. 2, pp. 678–700, 2nd Quart., 2013.
- [115] N. Abu-Ali, A.-E. M. Taha, M. Salah, and H. Hassanein, "Uplink scheduling in LTE and LTE-advanced: Tutorial, survey and evaluation framework," *IEEE Commun. Surveys Tuts.*, vol. 16, no. 3, pp. 1239–1265, 3rd Quart., 2014
- [116] D. Laselva, F. Capozzi, F. Frederiksen, K. Pedersen, J. Wigard, and I. Kovacs, "On the Impact of Realistic Control Channel Constraints on QoS Provisioning in UTRAN LTE," in *Proc. IEEE Veh. Tech. Conf., VTC-Fall*, Anchorage, Alaska, USA, Sep. 2009, pp. 1–5.
- [117] 3GPP, Tech. Specif. Group Radio Access Network - Persistent Scheduling in E-UTRA, 3GPP TSG-RAN WG1 R1-070098.
- [118] D. Jiang, H. Wang, E. Malkamaki, and E. Tuomaala, "Principle and performance of semi-persistent scheduling for VoIP in LTE system," in *Proc. IEEE Wireless Commun., Net. and Mobile Comput., WiCom*, Shanghai, China, Sep. 2007.
- [119] R. Kwan, C. Leung, and J. Zhang, "Proportional Fair Multiuser Scheduling in LTE," *IEEE Signal Process. Let.*, vol. 16, no. 6, pp. 461–464, Jun. 2009.
- [120] C. Wengert, J. Ohlhorst, and A. von Elbwart, "Fairness and throughput analysis for generalized proportional fair frequency scheduling in OFDMA," in *Proc. IEEE Veh. Tech. Conf., VTC-Spring*, vol. 3, Stockholm, Sweden, May 2005, pp. 1903–1907.
- [121] M. Proebster, C. Mueller, and H. Bakker, "Adaptive fairness control for a proportional fair LTE scheduler," in *Proc. IEEE Personal Indoor and Mobile Radio Commun., PIMRC*, Istanbul, Turkey, Sep. 2010, pp. 1504–1509.
- [122] X. Li, B. Li, B. Lan, M. Huang, and G. Yu, "Adaptive pf scheduling algorithm in LTE cellular system," in *Proc. Int. Conf. on Information and Commun. Tech. Convergence, ICTC*, Jeju Island, Korea, Nov. 2010, pp. 501–504
- [123] C. Hoymann et al., "LTE release 14 outlook," *IEEE Commun. Mag.*, vol. 54, no. 6, pp. 44–49, Jun. 2016.
- [124] S. A. Ashraf, I. Aktas, E. Eriksson, K. W. Helmersson, and J. Ansari, "Ultra-reliable and low-latency communication for wireless factory automation: From LTE to 5G," in *Proc. IEEE Int. Conf. Emerg. Technol. Factory Autom. (ETFA)*, Sep. 2016, pp. 1–8.
- [125] "Study on latency reduction techniques for LTE (release 14), v14.0.0," 3GPP, Sophia Antipolis, France, Rep. TR 36.881, Jun. 2016.
- [126] P. Zhou et al., "IEEE 802.11ay-Based mmWave WLANs: Design Challenges and Solutions," in *IEEE Communications Surveys & Tutorials*, vol. 20, no. 3, pp. 1654-1681, thirdquarter 2018. doi: 10.1109/COMST.2018.2816920
- [127] T. Adame, M. Carrascosa, and B. Bellalta, "Time-Sensitive Networking in IEEE 802.11be: On the Way to Low-latency WiFi", arxiv database, Available at: <https://arxiv.org/abs/1912.06086>
- [128] C. Deng et al., "IEEE 802.11be – Extremely High Throughput WLAN: New Challenges and Opportunities," in *IEEE Communications Surveys & Tutorials*, doi: 10.1109/COMST.2020.3012715.
- [129] M. Dano, "How much cellular and Wi-Fi data are smartphone users consuming, and with which apps?," *FierceWireless*, Jan. 24, 2017; [Accessed: Jun. 20, 2020]; available: <https://www.fiercewireless.com/wireless/how-much-cellular-and-wi-fi-data-are-smartphone-users-consuming-and-which-apps-verizon-0>
- [130] ITU Radiocommunication Sector, [Accessed: Jun. 22, 2020]; available: <https://www.itu.int/en/ITU-R/Pages/default.aspx>
- [131] Marco Carugi, "Distinguishing features - and high level requirements - of 5G/IMT-2020 networks", ITU-R Forum on Emergent Technologies, Tunisia, Tunis, 23-24 April 2019. [Accessed: Jun. 28, 2020]; available: <https://www.itu.int/en/ITU-D/Regional-Presence/ArabStates/Documents/events/2019/ET/S1-%20ITU%20Reg%20Forum-Tunis-5G%20IMT2020-presentation-Marco-Carugi-v1.pdf>
- [132] IEEE 802.11 WLANs, The Working Group for WLAN Standards, 2018.
- [133] IEEE, Proposed TGax draft specification, doc.: IEEE P802.11ax/D2.0, Oct. 2017, technical report, IEEE, 2017.
- [134] B. Bellalta, IEEE 802.11ax: High-Efficiency WLANs, *IEEE Wireless Commun.*, vol. 23, no. 1, 2016, pp. 38-46.
- [135] S. Kim et al. (2016). 11ax PAR Verification Through OFDMA. [Online]. Available: <https://mentor.ieee.org/802.11/dcn/16/11-16-1363-00-00ax-11ax-par-verification-through-ofdma.ppt>
- [136] E. Khorov, A. Kiryanov, A. Lyakhov and G. Bianchi, "A Tutorial on IEEE 802.11ax High Efficiency WLANs," in *IEEE Communications Surveys & Tutorials*, vol. 21, no. 1, pp. 197-216, First quarter 2019, doi: 10.1109/COMST.2018.2871099.
- [137] C. Ghosh et al. "Fragmentation With MU Operation," 2015. [Online Accessed: Jul. 2, 2020]. Available: <https://mentor.ieee.org/802.11/dcn/15/11-15-1102-00-00axfragmentation-with-mu-operation.pptx>
- [138] C. Wang et al. "UL Multi-TIDs Aggregation," 2015. [Online Accessed: Jul. 2, 2020]. Available: <https://mentor.ieee.org/802.11/dcn/15/11-15-1065-01-00ax11ax-uplink-multi-tid-aggregation.pptx>
- [139] A. Asterjadhri et al. "Fragmentation for MU Frames-Follow Up," 2015. [Online Accessed: Jul. 2, 2020]. Available: <https://mentor.ieee.org/802.11/dcn/16/11-16-005001-00ax-fragmentation-for-mu-frames-follow-up-on-acks.pptx>
- [140] C. Ghosh, "Random Access with Trigger Frames using OFDMA," [Online Accessed: Jul. 2, 2020]. Available:

- <https://mentor.ieee.org/802.11/dcn/15/11-15-0875-0100ax-random-access-with-trigger-frames-using-ofdma.pptx>
- [141] H. Kwon, H. Seo, S. Kim, and B. G. Lee, "Generalized CSMA/CA Protocol for OFDMA Systems," in IEEE Global Telecommunications Conference, New Orleans, LO, USA, 30 Nov.-4 Dec. 2008, pp. 1-6.
- [142] M. Nurchis and B. Bellalta, "Target Wake Time: Scheduled Access in IEEE 802.11ax WLANs," in IEEE Wireless Communications, vol. 26, no. 2, pp. 142-150, April 2019, doi: 10.1109/MWC.2019.1800163.
- [143] L. Lanante, C. Ghosh and S. Roy, "Hybrid OFDMA Random Access with Resource Unit Sensing for Next-gen 802.11ax WLANs," in IEEE Transactions on Mobile Computing, doi: 10.1109/TMC.2020.3000503.
- [144] N. Shahin, R. Ali, S. W. Kim and Y. Kim, "Cognitive back-off mechanism for IEEE802.11ax high-efficiency WLANs," in Journal of Communications and Networks, vol. 21, no. 2, pp. 158-167, April 2019, doi: 10.1109/JCN.2019.000022.
- [145] R. Ali, N. Shahin, Y. Kim, B. Kim, and S. W. Kim, "Channel observation-based scaled back-off mechanism for high-efficiency WLANs," IET Electronics Letters, vol. 54(10), pp. 663-665, May 2018
- [146] R. Ali, N. Shahin, Y. B. Zikria, B. Kim and S. W. Kim, "Deep Reinforcement Learning Paradigm for Performance Optimization of Channel Observation-Based MAC Protocols in Dense WLANs," in IEEE Access, vol. 7, pp. 3500-3511, 2019, doi: 10.1109/ACCESS.2018.2886216.
- [147] IEEE, "Status of Project IEEE P802.11be," IEEE P802.11-TASK GROUP BE (EHT) MEETING UPDATE, 2019, [Online Accessed: Jul. 1, 2020]. Available: http://www.ieee802.org/11/Reports/tgbe_update.htm.
- [148] E. Au et al., "Specification Framework for TGbe," IEEE 802.11 Documents, Feb. 2020. [Online]. Available: https://mentor.ieee.org/802.11/documents_is_dcn=1262&is_group=00be.
- [149] P. Huang et al., "Multi-link Operation Framework," IEEE 802.11 Documents, Jul. 2019. [Online]. Available: https://mentor.ieee.org/802.11/documents?is_dcn=0773&is_group=00be.
- [150] Y. Fang et al., "Multi-Link Architecture and Requirement Discussion," IEEE 802.11 Documents, Jul.2019. [Online]. Available: https://mentor.ieee.org/802.11/documents?is_dcn=1095&is_group=00be.
- [151] S. Nandagopalan et al., "Multiband and Multichannel Operation in IEEE 802.11be," IEEE 802.11 Documents, Jul. 2019. [Online]. Available: https://mentor.ieee.org/802.11/documents?is_dcn=1231&is_group=00be.
- [152] W. Ahn et al., "Wider Bandwidth Channel Access in EHT," IEEE 802.11 Documents, Jul.2019. [Online]. Available: https://mentor.ieee.org/802.11/documents?is_dcn=1242&is_group=00be.
- [153] L. Lu et al., "Discussion on Multi-band/Multi-channel Access Method," IEEE 802.11 Documents, May 2019. [Online]. Available: https://mentor.ieee.org/802.11/documents?is_dcn=951&is_group=00be.
- [154] D. Loghin et al., "The Disruptions of 5G on Data-driven Technologies and Applications," *IEEE Transactions on Knowledge and Data Engineering*, vol. 32, pp. 1179-1198, June 2020. DOI: 10.1109/TKDE.2020.2967670
- [155] S. Savazzi, M. Nicoli and V. Rampa, "Federated Learning with Cooperating Devices: A Consensus Approach for Massive IoT Networks," *IEEE Internet of Things Journal*, vol. 7, no. 5, pp. 4641-4654, May 2020. DOI: 10.1109/JIOT.2020.2964162
- [156] Y. Lu et al., "Differentially Private Asynchronous Federated Learning for Mobile Edge Computing in Urban Informatics," *IEEE Transactions on Industrial Informatics*, vol. 16, no. 3, pp. 2134-2143, March 2020. DOI: 10.1109/TII.2019.2942179
- [157] J. Kang et al., "Incentive Design for Efficient Federated Learning in Mobile Networks: A Contract Theory Approach," 2019 IEEE VTS Asia Pacific Wireless Communications Symposium (APWCS), Singapore, 2019, pp. 1-5. DOI: 10.1109/VTS-APWCS.2019.8851649
- [158] M. Yao et al., "Artificial Intelligence Defined 5G Radio Access Networks," *IEEE Communications Magazine*, vol. 57, no. 3, pp. 14-20, March 2019. DOI: 10.1109/MCOM.2019.1800629
- [159] Z. Yu et al., "Federated Learning-Based Proactive Content Caching in Edge Computing," 2018 IEEE Global Communications Conference (GLOBECOM), Abu Dhabi, United Arab Emirates, 2018, pp. 1-6. DOI: 10.1109/GLOCOM.2018.8647616
- [160] H. Ye and G. Y. Li, "Deep Reinforcement Learning for Resource Allocation in V2V Communications," 2018 IEEE International Conference on Communications (ICC), Kansas City, MO, 2018, pp. 1-6, doi: 10.1109/ICC.2018.8422586.
- [161] J. Konecny, H. B. McMahan, D. Ramage, and P. Richtarik, "Federated optimization: distributed machine learning for on-device intelligence," ArXiv preprint, vol. abs/1610.02527, 2016. [Online]. Available: <http://arxiv.org/abs/1610.02527>
- [162] S. Samarakoon, M. Bennis, W. Saad, and M. Debbah, "Federated learning for ultra-reliable low-latency V2V communications," in Proc. of IEEE Global Communications Conference (GLOBECOM), Abu Dhabi, UAE, Dec. 2018, pp. 1-7.
- [163] S. Samarakoon, M. Bennis, W. Saad and M. Debbah, "Distributed Federated Learning for Ultra-Reliable Low-Latency Vehicular Communications," in IEEE Transactions on Communications, vol. 68, no. 2, pp. 1146-1159, Feb. 2020, doi: 10.1109/TCOMM.2019.2956472.
- [164] H. B. McMahan, E. Moore, D. Ramage, S. Hampson, and B. A. y Arcas, "Communication-efficient learning of deep networks from decentralized data," arXiv preprint arXiv:1602.05629, Feb. 2017.
- [165] S. Ha, J. Zhang, O. Simeone, and J. Kang, "Coded federated computing in wireless networks with straggling devices and imperfect CSI," arXiv preprint arXiv:1901.05239, Jan. 2019.
- [166] O. Habachi, M. A. Adjif, and J. P. Cances, "Fast uplink grant for NOMA: A federated learning based approach," arXiv preprint arXiv:1904.07975, Mar. 2019.
- [167] G. Zhu, Y. Wang and K. Huang, "Broadband Analog Aggregation for Low-Latency Federated Edge Learning," in IEEE Transactions on Wireless Communications, vol. 19, no. 1, pp. 491-506, Jan. 2020, doi: 10.1109/TWC.2019.2946245.
- [168] M. Isaksson, K. Norrman, "Secure Federated Learning in 5G Mobile Networks," arXiv preprint arXiv:2004.06700v1, Apr. 2020.
- [169] N. I. Mowla, N. H. Tran, I. Doh and K. Chae, "AFRL: Adaptive federated reinforcement learning for intelligent jamming defense in FANET," in Journal of Communications and Networks, vol. 22, no. 3, pp. 244-258, June 2020, doi: 10.1109/JCN.2020.000015.
- [170] C. She et al., "Deep Learning for Ultra-Reliable and Low-Latency Communications in 6G Networks," in IEEE Network, vol. 34, no. 5, pp. 219-225, September/October 2020, doi: 10.1109/MNET.011.1900630.
- [171] C. Qi, Y. Hua, R. Li, Z. Zhao and H. Zhang, "Deep Reinforcement Learning With Discrete Normalized Advantage Functions for Resource Management in Network Slicing," in IEEE Communications Letters, vol. 23, no. 8, pp. 1337-1341, Aug. 2019, doi: 10.1109/LCOMM.2019.2922961
- [172] A. T. Z. Kasgari, W. Saad, M. Mozaffari and H. V. Poor, "Experienced Deep Reinforcement Learning With Generative Adversarial Networks (GANs) for Model-Free Ultra Reliable Low Latency Communication," in IEEE Transactions on Communications, vol. 69, no. 2, pp. 884-899, Feb. 2021, doi: 10.1109/TCOMM.2020.3031930.
- [173] G. Bianchi and I. Tinnirello, "Kalman filter estimation of the number of competing terminals in an IEEE 802.11 network," IEEE INFOCOM 2003. Twenty-second Annual Joint Conference of the IEEE Computer and Communications Societies (IEEE Cat. No.03CH37428), San Francisco, CA, 2003, pp. 844-852 vol.2. DOI: 10.1109/INFCOM.2003.1208922
- [174] Y. Dai, D. Xu, K. Zhang, Y. Lu, S. Maharjan and Y. Zhang, "Deep Reinforcement Learning for Edge Computing and Resource Allocation in 5G Beyond," 2019 IEEE 19th International Conference on Communication Technology (ICCT), Xi'an, China, 2019, pp. 866-870, doi: 10.1109/ICCT46805.2019.8947146.
- [175] Q. Luo, C. Li, T. H. Luan and W. Shi, "Collaborative Data Scheduling for Vehicular Edge Computing via Deep Reinforcement Learning," in IEEE Internet of Things Journal, doi: 10.1109/JIOT.2020.2983660.
- [176] Q. Qi, and Z. Ma, "Vehicular Edge Computing via Deep Reinforcement Learning," arXiv preprint arXiv:1901.04290v3, Feb. 2020.
- [177] J. Cosmas, et al., "A 5g radio-light sdn architecture for wireless and mobile network access in buildings," in 2018 IEEE 5G World Forum (5GWF), July 2018, pp. 135-140.
- [178] J. Kang, Z. Xiong, D. Niyato, Y. Zou, Y. Zhang, and M. Guizani, "Reliable federated learning for mobile networks," IEEE Wireless Communications, vol. 27, no. 2, pp. 72-80, 2020.
- [179] Y. Liu et al. "A Secure Federated Learning Framework for 5G Networks," arXiv preprint arXiv:2005.05752v1, May 2020.
- [180] R. Shokri, M. Stronati, C. Song, and V. Shmatikov, "Membership inference attacks against machine learning models," in 2017 IEEE Symposium on Security and Privacy (SP), May 2017, pp. 3-18.
- [181] Y. Wu, Y. Liu, S. H. Ahmed, J. Peng, and A. A. El-Latif, "Dominant dataset selection algorithms for electricity consumption time-series data analysis based on affine transformation," IEEE Internet of Things Journal, pp. 1-1, 2019.
- [182] L. Ruan, S. Mondal, I. Dias and E. Wong, "Low-Latency Federated Reinforcement Learning-Based Resource Allocation in Converged Access Networks," 2020 Optical Fiber Communications Conference and Exhibition (OFC), San Diego, CA, USA, 2020, pp. 1-3.

- [183] X. Chen, B. Li, R. Proietti, H. Lu, Z. Zhu and S. J. B. Yoo, "DeepRMSA: A Deep Reinforcement Learning Framework for Routing, Modulation and Spectrum Assignment in Elastic Optical Networks," in *Journal of Lightwave Technology*, vol. 37, no. 16, pp. 4155-4163, 15 Aug.15, 2019, doi: 10.1109/JLT.2019.2923615.
- [184] J. Suárez-Varela *et al.*, "Routing Based on Deep Reinforcement Learning in Optical Transport Networks," 2019 Optical Fiber Communications Conference and Exhibition (OFC), San Diego, CA, USA, 2019, pp. 1-3.
- [185] A. Musaddiq, Zulqarnain, Y. A. Qadri, R. Ali, and S. W. Kim, "Reinforcement Learning-Enabled Cross-layer Optimization for Low-power and Lossy Networks under Heterogeneous Traffic Patterns," *Sensors* 2020, 20(15), 4158.
- [186] Y. Zhang, R. Yu, S. Xie, W. Yao, Y. Xiao and M. Guizani, "Home M2M networks: Architectures, standards, and QoS improvement," in *IEEE Communications Magazine*, vol. 49, no. 4, pp. 44-52, April 2011, doi: 10.1109/MCOM.2011.5741145.
- [187] X. Liu, M. Qiu, X. Wang, W. Liu, and K. Cai, "Energy efficiency optimization for communication of air-based information network with guaranteed timing constraints," *Journal of Signal Processing Systems*, vol. 86, no. 2-3, pp. 299-312, Mar. 2017
- [188] C. Liu, W. Feng, Y. Chen, C. -X. Wang and N. Ge, "Cell-Free Satellite-UAV Networks for 6G Wide-Area Internet of Things," in *IEEE Journal on Selected Areas in Communications*, vol. 39, no. 4, pp. 1116-1131, April 2021, doi: 10.1109/JSAC.2020.3018837.



RASHID ALI (M'20) received his B.S. degree in Information Technology from Gomal University, Pakistan in 2007 and his M.S. degree under supervision of Dr. Stanislav Belenki in Computer Science (Advanced Network Design) in 2010 and M.S. degree in Informatics under the supervision of Dr. Maria Spante in 2012-13 from University West, Sweden. He received his Ph.D. diploma in Information and Communication Engineering from the Department of Information and Communication Engineering, Yeungnam University, Korea in February 2019.

Between 2007 and 2009, he worked for Wateen Telecom Pvt. Ltd. Pakistan as WiMAX Executive Engineer in Operations & Research Department. From July 2013 to June 2014, he worked for COMSATS University (Vehari), Pakistan, as a Lecturer. Currently, he is working as a PostDoc researcher at the School of Intelligent Mechatronics Engineering, Sejong University, Seoul, Korea. He has served as technical program committee member (TPC member) as well as reviewer for various international conferences. He is a regular reviewer of many well recognized journals of IEEE/ELSEVIER/MDPI/SAGE/IET. He is also a Guest Editor of special section of MDPI Electronics journal. His research interests include next-generation wireless local area networks (IEEE 802.11ax/ah), unlicensed wireless networks in 5G, Internet of Things (IoT), performance evaluation of wireless networks, Reinforcement Learning techniques for wireless networks, and Ultra-Reliable Low Latency Communications (URLLC) for Tactile Internet.



YOUSAF BIN ZIKRIA (SM'17) is currently working as an Assistant Professor in the department of Information and Communication Engineering, College of Engineering, Yeungnam University, Gyeongsan-Si, South Korea. He received a Ph.D. degree from the Department of Information and Communication Engineering, Yeungnam University, Korea, in 2016. He has more than 10 years of experience in research, academia and industry in the field of Information and Communication

engineering, and Computer science. He authored more than 70 scientific peer-reviewed journals, conferences, patent, book chapters. He taught numerous courses in the field of computer science and engineering, from reinforcement learning to computer networks. His research interests include IoT, 5G, reinforcement learning, wireless communications and networks, opportunistic communications, wireless sensor networks, routing protocols, cognitive radio ad hoc networks, cognitive radio ad hoc sensor networks, transport protocols, VANETS, embedded system, and information security. He served or currently serving as an associate/guest editor of served or serving as a guest editor for many SCIE journals that include IEEE Communications Magazine. He also chaired IEEE conferences workshop and tracks. Further, he is serving as the reviewer of IEEE Communications Surveys and Tutorials, IEEE Communications Magazine, IEEE Communications Letters, IEEE Sensors, IEEE ACCESS, IEEE IT Professional, Elsevier Future Generation Computer Systems, Elsevier Computer Standards and Interfaces, Springer the Journal of Supercomputing, Sage International Journal of Distributed Sensor Networks, and KSII Transactions on Internet and Information Systems etc. He is the recipient of the excellent paper award of ICIDB 2016 Conference and fully funded scholarship for Masters and Ph.D. He has previously held the prestigious CISA, JNCIS-SEC, JNCIS-ER, JNCIA-ER, JNCIA-EX, and Advance Routing Switching and WAN Technologies certifications.



ALI KASHIF BASHIR received the B.S. degree from UMT, Pakistan, the M.S. degree from Ajou University, South Korea, and the Ph.D. degree in computer science and engineering from Korea University, South Korea. He is currently with the School of Computing and Mathematics, Manchester Metropolitan University, U.K. He is also an Adjunct Professor with the School of Electrical Engineering and Computer Science, National University of Science and Technology, Islamabad

(NUST). He is a Distinguished Speaker of ACM. His past assignments include an Associate Professor of information and communication technologies with the Faculty of Science and Technology, University of the Faroe Islands, Denmark; Osaka University, Japan; the Nara National College of Technology, Japan; the National Fusion Research Institute, South Korea; Southern Power Company Ltd., South Korea, and the Seoul Metropolitan Government, South Korea. He has advised several startups in the field of STEM-based education, robotics, and smart homes. A few of these are RNS Solutions, Edvon, UHom, and Bandz Networks. He is the author of over 90 peer-reviewed articles. He is supervising/co-supervising several graduate (M.S. and Ph.D.) students. His research interests include the Internet of Things, wireless networks, distributed systems, network/cybersecurity, and cloud/network function virtualization. He has served as the (Program, Publicity, and Track) chair on several conferences and workshops. He has delivered several invited and keynote talks, and reviewed the technology leading articles for journals like the IEEE Transactions on Industrial Informatics, the IEEE Communication Magazine, the IEEE Communication Letters, the IEEE Internet of Things, and the IEICE Journals, and conferences, such as the IEEE Infocom, the IEEE ICC, the IEEE Globecom, and the IEEE Cloud of Things. He has been serving as the Editor-in-Chief for the IEEE Future Directions Newsletter. He is an editor of several journals and has served as a guest editor on several special issues in journals of IEEE, Elsevier, and Springer.



SAHIL GARG received the Ph.D. degree from the Thapar Institute of Engineering and Technology, Patiala, India, in 2018. He is currently a Postdoctoral Research Fellow with École de technologie supérieure, Université du Québec, Montréal, QC, Canada. He has many research contributions in the area of machine learning, big data analytics, security and privacy, Internet of Things, and cloud computing. He has authored or coauthored more than 50 publications in high ranked journals and

conferences, including more than 20 IEEE Trans./Journal papers. Some of his research findings are published in top-cited journals such as IEEE TII, IEEE TCC, IEEE TMM, IEEE TVT, IEEE TNSM, IEEE TSUSC, IEEE IoT Journal, IEEE Systems Journal, IEEE Communications Magazine, IEEE Network Magazine, IEEE Wireless Communications, IEEE Consumer Electronics Magazine, FGCS, JPDC, Applied Soft Computing, and Information Sciences, including various international conferences of repute such as-IEEE Globecom, IEEE ICC, IEEE WCNC, IEEE CCNC, IEEE VTC, IEEE Infocom Workshops, ACM MobiCom Workshops, ACM MobiHoc Workshops, etc. He was the recipient of prestigious Visvesvaraya Ph.D. fellowship from the Ministry of Electronics Information Technology under Government of India (2016–2018). For his research, he has also been awarded the IEEE ICC Best Paper Award in 2018 at Kansas City, USA. He serves as a Managing Editor for Springer’s Human-centric Computing and Information Sciences (HCIS) and an Associate Editor for Wiley’s International Journal of Communication Systems (IJCS). He has been a Lead Guest Editor for a number of special issues in prestigious journals and magazines, such as IEEE TII, IEEE T-ITS, IEEE IoT Journal, IEEE Network, and Elsevier’s FGCS. He also serves as a General and Publicity Chair for workshops, including IEEE Infocom, IEEE Globecom, and IEEE ICC. He is a member of IEEE Communications Society, IEEE Computer Society, IEEE Industrial Electronics Society, IEEE Software Defined Networks Community, IEEE Smart Grid Community, ACM, and IAENG.



HYUNG SEOK KIM received the B.S. degree from the School of Electrical Engineering, Seoul National University, South Korea, in 1996, and the M.S. and Ph.D. degrees from the School of Electrical Engineering and Computer Engineering, Seoul National University, in 1998 and 2004, respectively. In 2003 and 2004, he held visiting researcher positions with the University of Virginia. From 2004 to 2006, he was with the Telecommunication RD Center, Samsung Electronics. He is

currently a Faculty Member with the Department of Information and Communication Engineering, Sejong University. His research interests include networking with special emphasis on wireless communication and visual light communication.

...