



## Flying to the Clouds: The Evolution of the 5G Radio Access Networks

*Glauco E. Gonçalves, Guto L. Santos, Leylane Ferreira,  
Élisson da S. Rocha, Lubnnia M. F. de Souza,  
André L. C. Moreira, Judith Kelner, and Djamel Sadok*

**Abstract** The number of connected devices and the amount of data traffic exchanged through mobile networks is expected to double in the near future. Long Term Evolution (LTE) and fifth generation (5G) technologies are evolving to support the increased volume, variety and velocity of data and new interfaces the Internet of Things demands. 5G goes beyond increasing data throughput, providing broader coverage and reliable

---

G. E. Gonçalves (✉)

Rural Federal University of Pernambuco, Recife, Brazil

e-mail: [glauco.goncalves@ufpe.br](mailto:glauco.goncalves@ufpe.br)

D. Sadok • G. L. Santos • L. Ferreira • É. d. S. Rocha •

L. M. F. de Souza • A. L. C. Moreira • J. Kelner

Universidade Federal de Pernambuco, Recife, Brazil

e-mail: [jamel@gprt.ufpe.br](mailto:jamel@gprt.ufpe.br); [guto.leoni@gprt.ufpe.br](mailto:guto.leoni@gprt.ufpe.br); [leylane.silva@gprt.ufpe.br](mailto:leylane.silva@gprt.ufpe.br);

[elisson.rocha@gprt.ufpe.br](mailto:elisson.rocha@gprt.ufpe.br); [lmfs@ecomp.poli.br](mailto:lmfs@ecomp.poli.br); [andre@gprt.ufpe.br](mailto:andre@gprt.ufpe.br);

[jk@gprt.ufpe.br](mailto:jk@gprt.ufpe.br)

© The Author(s) 2020

T. Lynn et al. (eds.), *The Cloud-to-Thing Continuum*, Palgrave

Studies in Digital Business & Enabling Technologies,

[https://doi.org/10.1007/978-3-030-41110-7\\_3](https://doi.org/10.1007/978-3-030-41110-7_3)

ultra-low latency channels to support challenging future applications. However, this comes with a cost. As such, the architectural design of radio access network requires due consideration. This chapter explains why the radio access network is critical to 5G success and how novel trends on edge computing, network slicing and network virtualisation perform a critical role in optimising resources on emerging 5G infrastructures.

**Keywords** 5G • Network function virtualisation • Radio access networks • Cloud radio access networks

### 3.1 INTRODUCTION

The combination of widespread adoption of smartphones and the Internet of Things (IoT) presents telecommunications operators with significant challenges that legacy architectures were not designed to handle. An ever-increasing number of consumers use a plethora of bandwidth-intensive mobile applications, not least social media and video streaming, and device capabilities driven by affordable data plans. At the same time, the Internet of Things is driving data exchange; the number of smart end-points, for example, smart home and healthcare devices, will reach about 1.1 billion devices in 2022 (Cisco 2019). Globally, mobile devices and connections will grow to 12.3 billion by 2022 at a compound annual growth rate of 7.5% generating 77 exabytes (EB) of mobile traffic (Cisco 2019).

As discussed in Chap. 1, innovations such as Ipv6 and new paradigms in computing such as fog, edge and dew computing are enabling the IoT, however, LTE and 5G play a critical role in network connectivity. Furthermore, 5G, in particular will stimulate innovation and value through new applications and business models to support unprecedented connectivity and coverage. These applications and business models require increasingly heterogeneous and demanding service levels in terms of security, reliability, latency, throughput and so on (Li et al. 2018). In order to support these requirements, 5G technology evolves the 4G network through a new high frequency radio technology that provides greater data rates. Due to the smaller coverage of the high frequency radio technology, 5G needs more base stations to cover the same area than 4G, which in turn offers more resources to cope with the massive connectivity and low power demands of IoT devices. 5G technology can also ‘slice’ radio resources to offer more reliability, more bandwidth, or ultra-low latency

according to the demand of the heterogeneous services coexisting within the 5G network (Popovski et al. 2018).

One of the main economic issues for operators of mobile infrastructure is that the average revenue per user (ARPU) is not growing as quickly as the traffic demand. As such, network operators are looking for mechanisms to sweat legacy infrastructure and reduce costs:

*there has [...] been a need for cost-effective solutions that can help operators accommodate such huge amounts of mobile network traffic while keeping additional investment in the mobile infrastructure minimal.* (Taleb and Ksentini 2013, p. 12)

5G may be the answer. However, this may be a blessing in disguise. Firstly, while new business models and use cases may generate new value and revenue streams, it will also result in even greater heterogeneity, data, and QoS demands. Secondly, the cost of a 5G base station cost is estimated to be 4X of an equivalent Long-Term Evolution (LTE) base station and, due to the usage of higher frequencies, 5G is likely to need around 3 times more base stations to achieve the same coverage as 4G networks. Wisely et al. (2018) estimate that a 5G network with 100 times more capacity than a 4G network is 4 to 5 times more expensive than that 4G network. Finally, 5G's base station power consumption is estimated to reach 3X that of an LTE's. 5G uses massive multiple-input multiple-output (MIMO) antennas to perform beamforming and gain bandwidth. In contrast, LTE MIMO antennas usually use no more than 4 by 4 elements; 5G MIMO is expected to adopt 64 (at transmitter) by 64 (at receiver) antenna elements. It requires more power amplifiers and analogue-to-digital paths, and consequently increases power consumption to tens of kilowatts per base station. Clearly, the cost of deploying 5G is an important issue. Therefore, one solution is greater optimisation of the 5G radio access network (RAN) architecture in order to save resources. As a result, the telecommunication operators need to distribute their network infrastructure to the edge to cope with the growing number of mobile users and the related bandwidth-intensive mobile applications, minimising the communication path between users and services, and consequently decreasing the delay and alleviating pressure on core network operation. In this context, distributed cloud data centres, network virtualisation and slicing techniques (such as Software Defined Networking (SDN), Network Function Virtualisation (NFV), and Virtual Network Function (VNF))

perform critical roles in ensuring service availability, network enhancements and cost reduction. As Taleb et al. note

*Along with recent and ongoing advances in cloud computing and their support of virtualised services, it has become promising to design flexible, scalable, and elastic 5G systems benefiting from advanced virtualisation techniques of cloud computing and exploiting recent advances relevant to network function virtualisation.* (Taleb et al. 2016, p. 84)

Understanding the components of distributed data centres (at both the infrastructure and application levels) and the relationship between them is very useful for analysing and optimising both infrastructure and resource placement for composing VNF chains.

In this chapter, we provide a summary of the evolution of 5G architectures and explain why RAN designs are critical to 5G success and consequently, the success of IoT. We describe how the components and their functionalities evolved over time to meet the user and application requirements. We also present how some key technologies, such as SDN and NFV, support the evolution of cellular networks. We conclude with current research challenges and opportunities in this area.

## 3.2 THE EVOLUTION OF RADIO ACCESS NETWORKS (RANs)

The section outlines the evolution of RANs from Distributed RANs to Cloud RANs, Heterogeneous Cloud RANs and Fog Computing RANs.

### 3.2.1 *Distributed Radio Access Networks*

Early generations of cellular systems used to have a baseband unit (BBU) and remote radio head (RRH) components physically integrated and located at the bottom of a Base Station (BS) connected to a Radio Frequency (RF) antenna at the top of the tower through heavy electrical cables. However, this architecture presented significant RF signal propagation loss in the electrical cable feed resulting in degraded signal transmission/reception power and quality (Liu 2017). As a result, telecommunications operators began to adopt a separated BBU and RRH architecture based on distributed Radio Access Network (D-RAN or just RAN).

In D-RAN, as shown in Fig. 3.1, each BS is composed of two co-located components: (1) a digital unit (DU) or BBU, and (2) a radio unit (RU) or RRH; these two components were connected through a Common Public Radio Interface (CPRI). The BBU is the component responsible for baseband processing, that is processing calls and forwarding traffic. The RRH is responsible for digital radio signal processing by transmitting, receiving and converting signals, as necessary. Each BS is connected to the core network through a backhaul.

In conventional D-RAN architectures, improving the operational capacity of a cell means to densify the network however this results in increased cost as additional BS' need be deployed and each BS has an

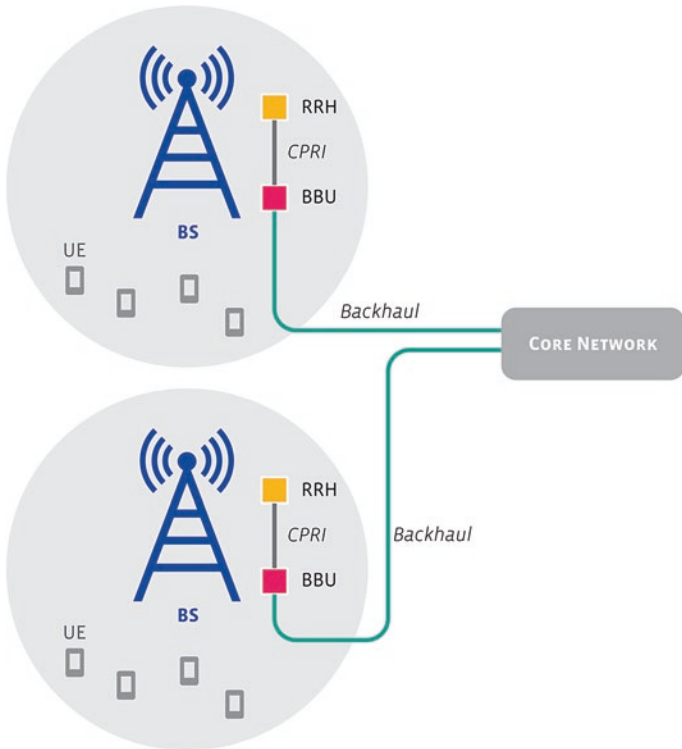

Fig. 3.1 A traditional D-RAN architecture

associated RRH and BBU. Additionally, in this scenario, the processing resources of a BBU cannot be shared among other RRHs.

Wang et al. (2017) propose an alternative means to improve the system by making use of technologies, such as coordinated multipoint (CoMP), to reduce the interference and increase the throughput. However, this solution has two main drawbacks: (1) it applies stringent delay constraints for control and signalling to guarantee on-time coordination between BS (NGMN Alliance 2015), and (2) it is not designed to deal with the processing capabilities of distributed BSs. As the volume of end users and complexity of the services offered by the operators has increased, new drawback in conventional D-RAN deployments emerged. For instance, average spectral efficiency gains of only 20% were observed in RAN deployments (Sun and Peng 2018). As a result, Cloud RANs (C-RANs) have emerged as a centralised solution, moving the BS functionalities to the cloud in order to optimise the resources and improve energy efficiency (Wu et al. 2015; Peng et al. 2015a, b).

### 3.2.2 *Cloud Radio Access Networks (C-RANs)*

The main design principle of C-RAN architecture is to relocate some of the cellular network functions to the cloud infrastructure. In 2010, IBM proposed a wireless network cloud (WNC) to decrease network costs and obtain more flexible network capabilities (Peng et al. 2011). In 2011, China Mobile Research Institute launched the C-RAN architecture and ZTE Corporation proposed network solutions to comply with the C-RAN requirements. Following this lead, many telecom operators started to develop new solutions based on virtualisation techniques in order to guarantee flexibility and take advantage of cloud features. Network operators understand that the main cost of 5G is incurred at the RAN, therefore they decided to invest in new types of open and low-cost architectures.

To address the main limitations present in traditional RANs, the RRH and BBU functions were physically decoupled in C-RAN architectures. As shown in Fig. 3.2, the RRH is kept at the BS but now the BBU is migrated to cloud infrastructure. To connect the BBU with the respective RRHs, there is a need for a high-speed and low-latency front-haul communication channel (Hossain et al. 2019; Ren et al. 2018); bandwidth requirements for these links depends on the level of the split between BBU pool located in the cloud and RRH. As presented in (Peng et al. 2015a, b), there are three different functional split of C-RAN architectures: (1) fully

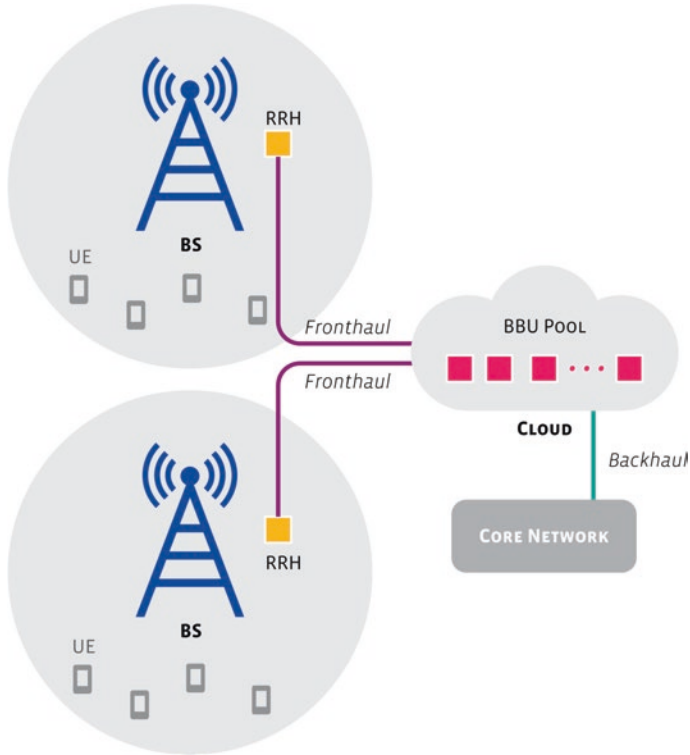

**Fig. 3.2** A general architecture of a C-RAN cellular network

centralised, (2) partially centralised and (3) hybrid. In the fully centralised, all processing and management functions of base stations are performed by the BBU pool at the cloud. This way, basically all data need to be transferred from RRH to the cloud, requiring a high bandwidth. In the partially centralised configuration, the RRH performs the functions related to RF, such as signal processing; and the other management functions are performed in the cloud by the BBU pool. This option reduces the bandwidth requirements between the RRH and the cloud. However, the interaction between processing and managing functions can be complex, making the separation difficult. In this case, the third type of split, the hybrid, moves some types of processing functions to the cloud and assigns them to a new separated process. This option facilitates the resource management and reduces the energy consumption on the cloud side.

The front-haul communication channel can be implemented using a wide variety of technologies including millimetre wave technologies, standard wireless communication, and optical fibre communication (Hossain et al. 2019). While fibre optics are used to support high transmission capacity, these are constrained by cost and deployment flexibility. Wireless technologies with 5–40 GHz carrier frequencies are lower cost and more flexible in terms of deployment. Liu (2017) notes that with C-RANS:

*...the conventional complicated and power-hungry cells can be simplified to RRH only, reducing capital expenditures (CAPEX) and operational expenditures (OpEx) related to power consumption and cell maintenance.* (Liu 2017, p. 221)

In this way, several RRHs can be deployed at distributed BS to provide seamless coverage and high throughput for a large number of users (Pan et al. 2018), while a pool of BBUs can share computational resources in the cloud infrastructure thereby optimising resource usage. As such, in C-RANS, the most intensive computational tasks are now performance in BBUs allocated in the cloud. These tasks include signal modulation, precoding matrix calculation, channel state information estimation, and Fourier transformation (Hossain et al. 2019; Wang et al. 2018). In addition, the monitoring of the RRHs operational status can be used to dynamically adapt the number of active BBUs in the cloud reducing the energy and operational cost (Pan et al. 2018).

As highlighted in Hossain et al. (2019), there are several advantages in adopting C-RAN architectures. In a traditional RAN architecture, the deployment and the commissioning of a new BS is very expensive and time-consuming. In contrast, in C-RAN systems, the deployment of an equivalent infrastructure is relatively easier since only a new RRH need be installed and associated BBU services deployed in the cloud. With this, it is possible to cover new areas or split the cell in order to improve its capacity. Suryaprakash et al. (2015) suggests that the adoption of C-RAN can reduce CAPEX by approx. 15%. Furthermore, it is possible to improve energy efficiency. As all BBUs are allocated in the cloud, the telecommunications operator is able to monitor the BBUs operation and apply strategies to dynamically change their mode (low power sleep mode or shut down) to save energy saving energy (Wu et al. 2015).

There are some drawbacks in adopting C-RANS, not least security. C-RAN architectures may suffer the same problems of traditional



networks, such as primary user emulation attack and spectrum sensing data falsification (Tian et al. 2017). In addition, if all BBUs run in the cloud, any problem in the cloud infrastructure can compromise the whole service operation. Peng et al. (2016a) note that centralised signal processing in the cloud can introduce the risk of higher latency. The constrained capacity of front-haul links is also a problem. This results in a significant negative impact on both energy efficiency and spectral efficiency (Sun and Peng 2018). Two proposed innovation to address these issues are heterogeneous C-RAN (H-CRAN) and fog RAN (F-RAN).

### 3.2.3 Heterogeneous Cloud Radio Access Networks

Heterogeneous CRAN (H-CRAN) is an architecture that takes advantage of two approaches: CRAN and Heterogeneous Networks (HetNets). HetNets are composed of a set of small cells that transmit signals with low power within a traditional macro cell network (Anpalagan et al. 2015). Hetnets allows short radio transmission distance resulting in reduced cost and promotes capacity enhancement (Yang et al. 2015).

Small cells can be classified as microcells, picocells, or femtocells. These types of cells are differentiated by output power, cell radius, number of users, and Distributed Antenna Systems (DAS) integration (see Table 3.1). DAS is a distributed version of a MIMO system that aims to provide spatial diversity to avoid path loss and shadowing. Consequently, the signal reception quality and the physical layer security at receivers are improved (Wang et al. 2016). H-CRANs, as well as HetNets, present different types of small cells in their architecture, which are spread along a macro cell coverage area (Marotta et al. 2017).

HetNets have two important types of nodes: high power nodes (HPNs) and low power nodes (LPNs). HPNs, such as macro cell base stations (MBS), are in charge of wide network coverage. LPNs, such as small cell

**Table 3.1** Cell specification. (Adapted from Mishra (2018))

	<i>Femto cells</i>	<i>Pico cells</i>	<i>Micro cells</i>	<i>Macro cells</i>
Output power	1–250 mW	250 mW–1 W	1–10 W	10–50+ W
cell radius	10–100 m	100–200 m	0.2–2 km	8–30 km
Users	1–30	30–100	100–2000	2000+
DAS integration	No	Yes	Yes	Yes

base stations (SBS), are low powered nodes densely deployed, offering high data rates in hot spots and seamless mobility, referring to the SBSs (Sun and Peng 2018). To manage complexity and for efficiency and cost-effectiveness, HetNets support self-organisation, allowing cooperation between the base stations to optimally coordinate their resources.

The use of HetNet HPNs brings advantages to C-RAN architectures in terms of backward compatibility and seamless coverage in cellular networks, since in a C-RAN architecture, RRHs focus on high capacity instead of coverage. Furthermore, HPNs enable convergence of multiple heterogeneous radio networks and control signaling in the network (Alimi et al. 2017). In H-CRAN architectures, RRHs assume the role of LPNs by performing simple functions (such as radio frequency management and simple symbol processing). The BBU is responsible for coordination between HPNs and RRHs to mitigate inter-tier interference. The BBU pool is also responsible for important upper layer functions (Sun and Peng 2018; Ali et al. 2017).

In H-CRANs, the control and data plane are decoupled. Data rate is the responsibility of an RRH (LPN) while control plane functionality is allocated to HPNs (Zhang and Wang 2016; Ali et al. 2017). Figure 3.3 presents an H-CRAN architecture and its elements. The HPN located in the macro cell communicates with SBS' through the control plane. RRHs located in small cells communicate by front-haul with the BBU pool through the data plane. In this architecture, the communication from the HPN to the cloud, from the cloud to the core network, and from the core network to the HPN are done by the back-haul channel.

### 3.2.4 *Fog Computing Radio Access Networks*

Fog Computing Radio Access Network (F-RAN) exploits the edge and storage capabilities of fog computing to address the front-haul constraints of previous architectures C-RANs and H-CRANs. The C-RAN and H-CRAN architectures centralise their software process at the cloud resulting in a heavy load on the front-haul link. To mitigate this problem, Peng et al. (2016b) proposed the F-RAN architecture based on the H-CRAN architecture with the addition of two components: (1) a fog computing-based access point (F-AP), RRH equipment with caching, cooperative signal processing, and radio resource management (RRM); and (2) fog user equipment (F-UE), a smart user terminal that also contains caching, cooperative signal processing, and RRM. With both

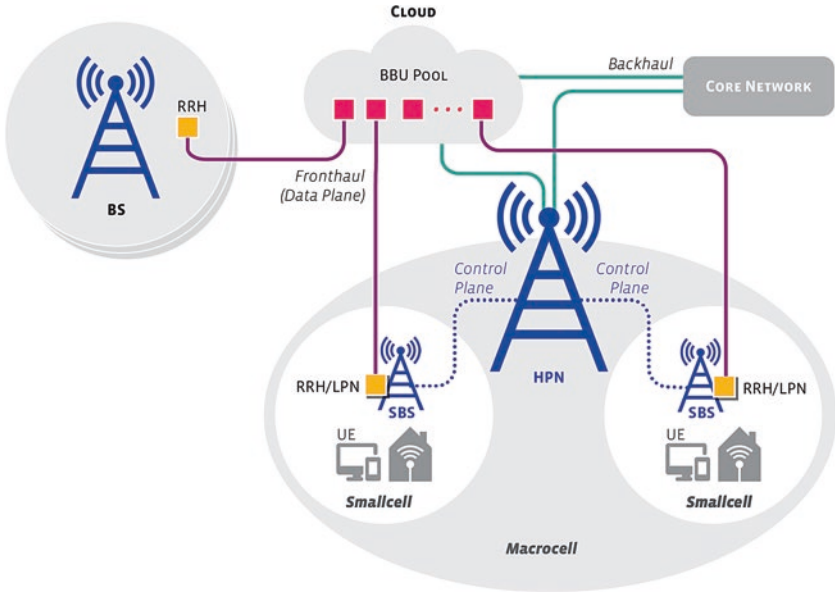

Fig. 3.3 An H-CRAN architecture

components, the proposed architecture (Fig. 3.4) receives local traffic from the F-APs or F-UEs, preventing traffic overloads from the front-haul to the cloud BBU.

The F-UEs can communicate to each other through an adaptive technique device-to-device (D2D) or using the F-UE based relay mode. For instance, the F-UE can exchange data directly with another F-UE using the D2D technology (Peng et al. 2016b). Meanwhile, the relay mode uses an F-UE as intermediary communication to other F-UEs. As mentioned earlier, the F-APs are RRH equipment that store a content cache and are used to forward and process incoming data. Because the F-APs and F-UEs contain caching, the control plane and part of the data plane can be transferred to them. As such, some requests will be processed locally addressing front-haul limitations (Peng et al. 2016b).

Although the F-RAN aims to minimise the disadvantages of C-RAN and H-CRAN, some questions about the new architecture are still open, such as caching, SDN and NFV. Caching on F-AP and F-UE devices requires intelligent resource allocation strategies to be efficient and thus

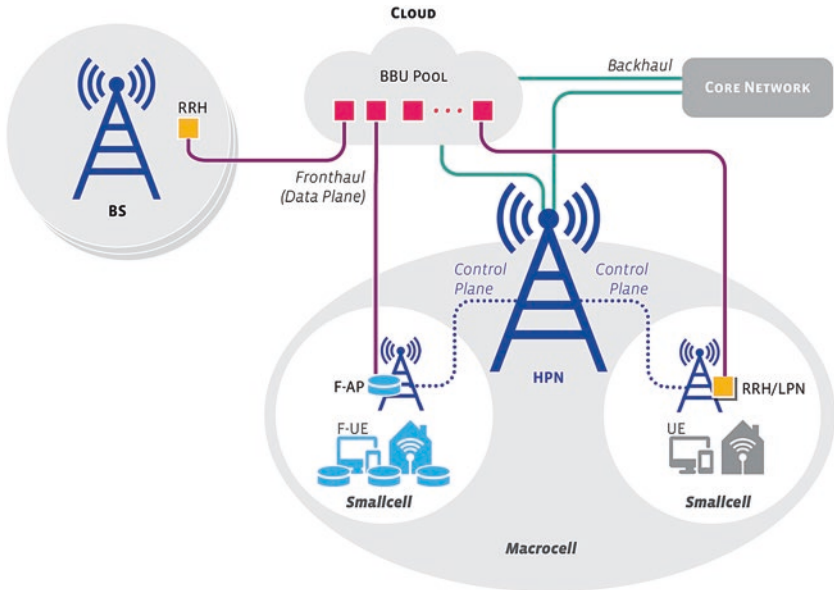

Fig. 3.4 An F-RAN architecture

alleviate front-haul overhead. Device caching is limited and can save little data locally. Thus, if both resource allocation and caching are not efficient, using F-RAN will not make sense and will not help with front-haul relief (Peng et al. 2016b). SDN, originally designed to be applied in wired networks, has been adapted for use in F-RANs. However, its structure is based on a centralised operation, while the F-RAN is based on a distributed one. As such, SDN needs to be adapted to this new context. In the same way, virtualising the SDN controller in F-RAN architectures remains a challenge (Guizani and Hamdi 2017).

### 3.3 NETWORK FUNCTION VIRTUALISATION AND 5G NETWORKS

5G networks deliver six benefits: high capacity, high data rate, low end-to-end latency, reduced costs, improvement of energy efficiency, and massive device connectivity (Zhang et al. 2015). Consequently, it needs ultra-densified networks, device-centric architecture, and specialised hardware.

There is also a need to coexist with legacy infrastructures, e.g. 2G, 3G, and 4G technologies, which increases management cost and complexity. A solution to address these factors is to implement the 5G network functions as software components using NFV (Alimi et al. 2017).

The initial purpose of NFV was to reduce CapEx and OpEx using virtualisation technology and to allow network operators sweat legacy infrastructure. NFV implements, through virtualisation technologies and leveraging standard servers, network functions in software, instead of running them on purpose-built hardware (Gomes et al. 2015). SDN enables the network operator to manage network functions through the abstract lower-level functionality, separating the control plane and data plane. At the same time, NFV is a technology that enables flexible and fast deployment of network functions in commodity devices instead of dedicated purpose-built hardware (Zeng et al. 2017). The combination of NFV and SDN brings several advantages for the network operator such as energy efficiency, network programmability (Miozzo et al. 2018; De Souza et al. 2018), network slicing (Ordonez-Lucena et al. 2017; Chartsias et al. 2017; Zhang et al. 2015; ETSI 2013; Zhou et al. 2016; Schiller et al. 2015), and dynamic bandwidth adjustment to reduce the delay (Zhang et al. 2015; Jahan 2015). For example, it is possible to identify the optimal resources to meet a specific demand and allocate them into the network using SDN/NFV (De Souza et al. 2018). SDN/NFV is increasingly being adopted by network operators not only for reduced CapEx and OpEx but also because it offers new service and revenue generation opportunities from legacy infrastructure by reducing the maturation cycle, deploying services faster (reduced time to market), and targeting particular customer segments or geographic markets with specific software and software configurations (Lynn et al. 2018).

In an effort to improve C-RANs, NFV has been used to virtualise the RAN architecture (ETSI 2013; Peng et al. 2015a, b; Rost et al. 2014; Dawson et al. 2014; Peña et al. 2019). ETSI outline a virtualised RAN use case in a C-RAN architecture where the BBU functions can be executed in a Network Function Virtualisation Infrastructure (NFVI) environment, such as a data centre. Peng et al. (2015a) used a H-CRAN solution based on NFV that included virtualised radio and computing resources for both intra and inter RAN technologies. Rost et al. (2014) proposed RAN-as-a-Service (RANaaS) to ensure flexible a functional split between a centralised cloud (e.g. C-RAN) and a distributed operation (in conventional mobile networks). They sought to take advantage of the flexibility of

virtualised RAN functions, while delay-stringent functions remained at the BS' with the less stringent ones deployed centrally in the cloud. Dawson et al. (2014) proposed a virtual network architecture for Cloud-RAN base stations that presents the core network with an abstracted view of the physical network. Abdelwahab et al. (2016) explored the potential of NFV for enhancing the functional, architectural, and commercial feasibility of 5G RANs including increased automation, operational agility, and reduced CapEx.

The RECAP project developed the next generation of cloud, edge and fog computing resource management, that supports complex applications and networks, and make use of network and service function virtualisation to handle heterogeneous underlying architectures and dynamic resource provisioning. Representative uses cases were proposed to demonstrate the challenges and one of the use cases is owned by TIETO, the largest IT service company in the Nordics. TIETO provides new solutions leveraging on the possibilities enabled by 4G and beyond mobile technologies in conjunction with cloud and fog computing. Through the RECAP project, TIETO evaluated 5G technologies by simulating network characteristics and QoS requirements, focused on improving reliability and reducing network latency. The RECAP solution for TIETO relies on SDN and VNF to dynamically provide resources (application placement and infrastructure optimisation) considering the QoS and QoE requirements (Peña et al. 2019).

### 3.4 CHALLENGES AND FUTURE DIRECTIONS

C-RAN is currently established as an alternative to the distributed cellular RAN. It centralises mobile network functions and is shown to consistently reduce capital and operational expenditures of such networks. Despite this, there is currently a number of opportunities for architectural improvements.

In order to meet the requirements of 5G deployments, C-RAN technology must evolve to reduce the costs of high-speed front-haul networks. CPRI-based front-haul demands high data rates (typically 10 to 24 Gbps per RRH) and small latency (100  $\mu$ s to 400  $\mu$ s) due to the nature of the I/Q data (Gomes et al. 2015). As such, options like Ethernet-based links appear as cost effective alternatives to replace CPRI as they are based on low-cost equipment and it brings statistical multiplexing capabilities to the

front-haul. Despite offering high data rates, Ethernet presents delay and synchronisation issues that remain as barriers to further adoption.

Greater energy efficiency is critical for future 5G mobile networks. The deployment of small 5G cells and heterogeneous networks will increase network energy demands. Harvesting ambient energy (through solar and wind power technology) are needed to make such deployments economically feasible and environmentally sustainable thus reducing energy consumption. At the same time, strategies to conserve energy at BBUs and RRHs (sleep mode) will be more and more employed (Hossain et al. 2019).

Even though the advantages of H-CRAN are well-documented, there are some open challenges in terms of operability. Front-haul and backhaul links may suffer additional burden due to the increasingly massive volumes of data received by the BBU pool (Zhang et al. 2017). The high density of base stations also may result in issues in H-CRAN architecture, such as inefficient resource usage, signal interference and degraded throughput in cases where distant cells are located at the cloud edge (Tran et al. 2017).

Supporting a massive amount of device-to-device communications brings several challenges that must be overcome in order to make 5G radio access the main infrastructure for the IoT. First, new IoT services and applications will change the traffic matrix at the RAN, as there will be an increase in connections between devices at the edge and between these devices and the distributed applications hosted close to the BBU. Such a traffic matrix will lead the front-haul to change uplink and downlink requirements. Second, the sheer mass of new IoT devices will bring new mobility management issues due to the increase in handoff and location operations. This will, in turn, be impacted by the centralised nature of C-RANs that can impose additional latency to perform these operations. To manage the complexity inherent in such a massive volume of heterogeneous and geographically distributed end-points, self-organisation presents itself as a solution and an avenue for further research (Hossain et al. 2019).

In terms of security, C-RAN technology is subject to threats from cloud systems and cellular systems (Hossain et al. 2019). Research in this area needs to employ security frameworks and techniques from both worlds (cloud and cellular) to promote new solutions for maintaining user privacy, trust among devices in HetNets, and among devices from different operators. The security challenges also extend to physical security. Wireless communications, by their nature, are susceptible to eavesdropping, and standard solutions based on encryption often impose infeasible or

unacceptable computing and communication overheads. This way, development of strategies to exploit the physical characteristics of the radio channel for security is an active research field (Peng et al. 2016a)

### 3.5 CONCLUSION

Radio access networks, and 5G technologies in particular, provide the network connectivity to enable the Internet of Things. In this chapter, a survey is presented on the evolution and improvements of radio access networks for 5G cellular networks (D-RAN, C-RAN, H-CRAN, and F-RAN) by presenting their infrastructure details, advantages, and limitations. A selection of key emerging technologies, such as SDN and NFV, and their benefits are also discussed. 5G deployments, energy efficiency, massive device-to-device communications, and security in RAN-based architectures all present potentially fruitful and necessary avenues for research as the adoption of the Internet of Things accelerates. We believe that this survey serves as a guideline for future research in 5G networks, as well as a motivator to think about on the next generation 5G RAN architectures for the Internet of Things.

### REFERENCES

- Abdelwahab, S., B. Hamdaoui, M. Guizani, and T. Znati. 2016. Network Function Virtualization in 5G. *IEEE Communications Magazine* 54: 84–91.
- Ali, M., Q. Rabbani, M. Naeem, S. Qaisar, and F. Qamar. 2017. Joint User Association, Power Allocation, and Throughput Maximization in 5G H-CRAN Networks. *IEEE Transactions on Vehicular Technology* 66 (10): 9254–9262.
- Alimi, Isiaka A., P.M. Paulo, and L.T. António. 2017. Outage Probability of Multiuser Mixed RF/FSO Relay Schemes for Heterogeneous Cloud Radio Access Networks (H-CRANs). *Wireless Personal Communications* 95 (1): 27–41.
- Alliance, N.G.M.N. 2015. Ran Evolution Project Comp Evaluation And Enhancement. Accessed 10 March 2019. [https://pdfs.semanticscholar.org/8e35/148ab1530342ca7c3659bfbf5c1e454945.pdf?\\_ga=2.25742072.478265301.1575550962-2016605258.1575550962](https://pdfs.semanticscholar.org/8e35/148ab1530342ca7c3659bfbf5c1e454945.pdf?_ga=2.25742072.478265301.1575550962-2016605258.1575550962)
- Anpalagan, A., B. Mehdi, and V. Rath. 2015. *Design and Deployment of Small Cell Networks*. Cambridge University Press.
- Chartsias, P. K., A. Amiras, I. Plevrakis, I. Samaras, K. Katsaros, D. Kritharidis, E. Trouva, I. Angelopoulos, A. Kourtis, M. S. Siddiqui, A. Viñes, and E. Escalona. 2017. *SDN/NFV-based End to End Network Slicing for 5G Multi-tenant Networks*. Paper presented at European Conference on Networks and Communications (EuCNC). IEEE. <https://ieeexplore.ieee.org/document/7980670>.



- Cisco. 2019. Cisco Visual Networking Index: Global Mobile Data Traffic Forecast Update, 2017–2022. <https://www.cisco.com/c/en/us/solutions/collateral/service-provider/visual-networking-index-vni/white-paper-c11-738429.pdf>
- Dawson, A.W., M.K. Marina, and F.J. Garcia. 2014. *On the Benefits of RAN Virtualisation in C-RAN based Mobile Networks*. Paper presented at Third European Workshop on Software Defined Networks, London, 103–108.
- De Souza, Phelipe A., Abdallah S. Abdallah, Elivelton F. Bueno, and Kleber V. Cardoso. 2018. *Virtualized Radio Access Networks: Centralization, Allocation, and Positioning of Resources*. IEEE International Conference on Communications Workshops (ICC Workshops), May.
- Gomes, N.J., P. Chanclou, P. Turnbull, A. Magee, and V. Jungnickel. 2015. Fronthaul/Evolution: From CPRI to Ethernet. *Optical Fiber Technology* 26: 50–58.
- Guizani, Z., and N. Hamdi. 2017. CRAN, H-CRAN, and F-RAN for 5G Systems: Key Capabilities and Recent Advances. *International Journal of Network Management* 27 (5): e1973.
- Hossain, Md F., Ayman U. Mahin, T. Debnath, Farjana B. Mosharrof, and Khondoker Z. Islam. 2019. Recent Research in Cloud Radio Access Network (C-RAN) for 5G Cellular Systems-A Survey. *Journal of Network and Computer Applications* 139: 31–48.
- Jahan, R. 2015. Unlocking the True Potential of 5G: Techniques for Latency Reduction.
- Li, Shancang, Li Da Xu, and Shanshan Zhao. 2018. 5G Internet of Things: A Survey. *Journal of Industrial Information Integration* 10: 1–9.
- Liu, C. 2017. *Architectural Evolution and Novel Design of Fiber-Wireless Access Networks*. Springer.
- Lynn, T., A. Gourinovitch, S. Svorobej, and P. Endo. 2018. Software Defined Networking and Network Functions Virtualization. Accessed 19 July 2019. <https://recap-project.eu/news/software-defined-networking-and-network-functions-virtualization/>
- Marotta, Marcelo A., M. Kist, Juliano A. Wickboldt, Lisandro Z. Granville, J. Rochol, and Cristiano B. Both. 2017. Design Considerations for Software-Defined Wireless Networking in Heterogeneous Cloud Radio Access Networks. *Journal of Internet Services and Applications* 8 (1): 18.
- Miozzo, M., N. Bartzoudis, M. Requena, O. Font-Bach, P. Harbanau, D. López-Bueno, M. Payaró, and J. Mangues. 2018. *SDR and NFV Extensions in the NS-3 LTE Module for 5G Rapid Prototyping*. IEEE Wireless Communications and Networking Conference (WCNC), June.
- Mishra, A. 2018. *Fundamentals of Network Planning and Optimisation 2G/3G/4G: Evolution to 5G*. India: Wiley. Accessed 10 March 2019. <https://books.google>.

- [com.br/books?id=pbpmDwAAQBAJ&printsec=frontcover&hl=pt-BR&source=gbs\\_ge\\_summary\\_r&cad=0#v=onepage&q&f=false](http://com.br/books?id=pbpmDwAAQBAJ&printsec=frontcover&hl=pt-BR&source=gbs_ge_summary_r&cad=0#v=onepage&q&f=false)
- Network Functions Virtualisation (NFV). 2013. Use Cases, ETSI, Sophia Antipolis, France.
- Ordóñez-Lucena, J., P. Ameigeiras, D. Lopez, Juan J. Ramos-Munoz, J. Lorca, and J. Folgueira. 2017. Network Slicing for 5G with SDN/NFV: Concepts, Architectures, and Challenges. *IEEE Communications Magazine* 55 (5): 80–87.
- Pan, C., M. Elkashlan, J. Wang, J. Yuan, and L. Hanzo. 2018. User-Centric C-RAN Architecture for Ultra-dense 5G Networks: Challenges and Methodologies. *IEEE Communications Magazine* 56: 14–20.
- Peña, M.A.L., Hector Humanes, J. Forsman, T. Le Duc, P. Willis, and M. Noya. 2019. Case Studies in Application Placement and Infrastructure Optimisation.
- Peng, M., Y. Liu, D. Wei, W. Wang, and H.H. Chen. 2011. Hierarchical Cooperative Relay based Heterogeneous Networks. *IEEE Wireless Communications* 18 (3): 48–56.
- Peng, M., Y. Li, Z. Zhao, and C. Wang. 2015a. System Architecture and Key Technologies for 5G Heterogeneous Cloud Radio Access Networks. *IEEE Network* 29 (2): 6–14.
- Peng, M., C. Wang, V. Lau, and H.V. Poor. 2015b. Fronthaul-Constrained Cloud Radio Access Networks: Insights and Challenges. *arXiv preprint arXiv:1503.01187*.
- Peng, M., Y. Sun, X. Li, Z. Mao, and C. Wang. 2016a. Recent Advances in Cloud Radio Access Networks: System Architectures, Key Techniques, and Open Issues. *IEEE Communications Surveys & Tutorials* 18 (3): 2282–2308.
- Peng, M., S. Yan, K. Zhang, and C. Wang. 2016b. Fog Computing Based Radio Access Networks: Issues and Challenges. *IEEE Network* 30 (4): 46–53.
- Popovski, Petar, Kasper Fløe Trillingsgaard, Osvaldo Simeone, and Giuseppe Durisi. 2018. 5G Wireless Network Slicing for eMBB, URLLC, and mMTC: A Communication-Theoretic View. *IEEE Access* 6: 55765–55779.
- Ren, H., N. Liu, C. Pan, M. Elkashlan, A. Nallanathan, X. You, and L. Hanzo. 2018. Low-Latency C-RAN: An Next-Generation Wireless Approach. *IEEE Vehicular Technology Magazine*, April.
- Rost, P., Carlos J. Bernardos, A. De Domenico, M. Di Girolamo, M. Lalam, A. Maeder, D. Sabella, and D. Wübben. 2014. Cloud Technologies for Flexible 5G Radio Access Networks. *IEEE Communications Magazine* 52 (5): 68–76.
- Schiller, E., N. Nikaein, R. Favraud, and K. Kostas. 2015. *Network Store: Exploring Slicing in Future 5G Networks*. Paper presented at 10th ACM Workshop on Mobility in the Evolving Internet Architecture (ACM MobiArch). <https://doi.org/10.1145/2795381.2795390>.
- Sun, Y., and M. Peng. 2018. Recent Advances of Heterogenous Radio Access Networks: A Survey. *Journal of Mobile Multimedia* 14 (4): 345–366.

- Suryaprakash, V., R. Peter, and F. Gerhard. 2015. Are Heterogeneous Cloud-based Radio Access Networks Cost Effective? *IEEE Journal on Selected Areas in Communications* 33 (10): 2239–2251.
- Taleb, T., and A. Ksentini. 2013. Follow Me Cloud: Interworking Federated Clouds and Distributed Mobile Networks. *IEEE Network* 27 (5): 12–19.
- Taleb, T., A. Ksentini, and R. Jantti. 2016. “Anything as a Service” for 5G Mobile Systems. *IEEE Network* 30 (6): 84–91.
- Tian, F., Z. Peng, and Y. Zheng. 2017. A Survey on C-RAN Security. *IEEE Access* 5: 13372–13386.
- Tran, Huu Q., Phuc Q. Truong, Ca V. Phan, and Quoc-Tuan Vien. 2017. *On the Energy Efficiency of NOMA for Wireless Backhaul in Multi-tier Heterogeneous CRAN*. Paper presented at International Conference on Recent Advances in Signal Processing, Telecommunications & Computing (SigTelCom). IEEE. <https://ieeexplore.ieee.org/document/7849827>.
- Wang, H., C. Wang, Derrick Wing K. Ng, H. Lee Moon, and J. Xiao. 2016. Artificial Noise Assisted Secure Transmission for Distributed Antenna Systems. *IEEE Transactions on Signal Processing* 64 (15): 4050–4064.
- Wang, X., C. Cavdar, L. Wang, M. Tornatore, H.S. Chung, H.H. Lee, S.M. Park, and B. Mukherjee. 2017. Virtualized Cloud Radio Access Network for 5G Transport. *IEEE Communications Magazine* 55: 202–209.
- Wang, K., Y. Kun, and Sarathchandra M. Chathura. 2018. Joint Energy Minimization and Resource Allocation in C-RAN with Mobile Cloud. *IEEE Transactions on Cloud Computing* 6: 760–770.
- Wisely, D., Ning Wang, and Rahim Tafazolli. 2018. Capacity and Costs for 5G Networks in Dense Urban Areas. *IET Communications* 12 (19): 2502–2510.
- Wu, J., Z. Zhang, Y. Hong, and Y. Wen. 2015. Cloud Radio Access Network (C-RAN): A Primer. *IEEE Network* 29: 35–41.
- Yang, C., Z. Chen, B. Xia, and J. Wang. 2015. When ICN Meets C-RAN for HetNets: An SDN Approach. *IEEE Communications Magazine* 53 (11): 118–125.
- Zeng, D., J. Zhang, S. Guo, L. Gu, and K. Wang. 2017. Take Renewable Energy into CRAN Toward Green Wireless Access Networks. *IEEE network* 31 (4): 62–68.
- Zhang, Y., and Y. Wang. 2016. *A Framework for Energy Efficient Control in Heterogeneous Cloud Radio Access Networks*. Paper presented at IEEE/CIC International Conference on Communications in China (ICCC Workshops). IEEE. <https://ieeexplore.ieee.org/document/7586713>.
- Zhang, J., W. Xie, and F. Yang. 2015. *An Architecture for 5G Mobile Network based on SDN and NFV*. Paper presented at 6th International Conference on Wireless, Mobile and Multi-Media (ICWMMN 2015). IEEE. <https://ieeexplore.ieee.org/document/7453882>.

- Zhang, H., Y. Qiu, X. Chu, K. Long, and Victor C.M. Leung. 2017. Fog Radio Access Networks: Mobility Management, Interference Mitigation, and Resource Optimization. *IEEE Wireless Communications* 24 (6): 120–127.
- Zhou, X., R. Li, T. Chen, and H. Zhang. 2016. Network Slicing as a Service: Enabling Enterprises' Own Software-Defined Cellular Networks. *IEEE Communications Magazine* 54 (7): 146–153.

**Open Access** This chapter is licensed under the terms of the Creative Commons Attribution 4.0 International License (<http://creativecommons.org/licenses/by/4.0/>), which permits use, sharing, adaptation, distribution and reproduction in any medium or format, as long as you give appropriate credit to the original author(s) and the source, provide a link to the Creative Commons licence and indicate if changes were made.

The images or other third party material in this chapter are included in the chapter's Creative Commons licence, unless indicated otherwise in a credit line to the material. If material is not included in the chapter's Creative Commons licence and your intended use is not permitted by statutory regulation or exceeds the permitted use, you will need to obtain permission directly from the copyright holder.

