



CISTER

Research Centre in
Real-Time & Embedded
Computing Systems

**IEEE 802.15.4e in a Nutshell: Survey and
Performance Evaluation**
Journal Paper

Harrison Kurunathan

Ricardo Severino

Anis Koubâa

Eduardo Tovar

CISTER-TR-180203

IEEE 802.15.4e in a Nutshell: Survey and Performance Evaluation

Harrison Kurunathan, Ricardo Severino, Anis Koubâa, Eduardo Tovar

*CISTER Research Centre

Polytechnic Institute of Porto (ISEP-IPP)

Rua Dr. António Bernardino de Almeida, 431

4200-072 Porto

Portugal

Tel.: +351.22.8340509, Fax: +351.22.8321159

E-mail:

<http://www.cister.isep.ipp.pt>

Abstract

The advancements in information and communication technology in the past decades have been converging into a new communication paradigm in which everything is expected to be interconnected. The Internet of Things (IoT), more than a buzzword, is becoming a reality, and is finding its way into the industrial domain, enabling what is now dubbed as the Industry 4.0. Among several standards that help in enabling Industry 4.0, the IEEE 802.15.4e standard addresses requirements such as increased robustness and reliability. Although the standard seems promising, the technology is still immature and rather unproven. Also, there has been no thorough survey of the standard with emphasis on the understanding of the performance improvement in regards to the legacy protocol IEEE 802.15.4. In this survey, we aim at filling this gap by carrying out a performance analysis and thorough discussions of the main features and enhancements of IEEE 802.15.4e. We also provide a literature survey concerning the already proposed add-ons and available tools. We believe this work will help to identify the merits of IEEE 802.15.4e and to contribute towards a faster adoption of this technology as a supporting communication infrastructure for future industrial scenarios.

IEEE 802.15.4e in a Nutshell: Survey and Performance Evaluation

Harrison Kurunathan[§], Ricardo Severino[§], Anis Koubaa^{§*}, Eduardo Tovar[§]

[§]CISTER/INESC TEC and ISEP-IPP, Porto, Portugal

* Prince Sultan University, Saudi Arabia. Email: (hkur, rarss, emt)@isep.ipp.pt, akoubaa@psu.edu.sa



Abstract—The advancements in information and communication technology in the past decades have been converging into a new communication paradigm in which everything is expected to be interconnected. The Internet of Things (IoT), more than a buzzword, is becoming a reality, and is finding its way into the industrial domain, enabling what is now dubbed as the Industry 4.0. Among several standards that help in enabling Industry 4.0, the IEEE 802.15.4e standard addresses requirements such as increased robustness and reliability. Although the standard seems promising, the technology is still immature and rather unproven. Also, there has been no thorough survey of the standard with emphasis on the understanding of the performance improvement in regards to the legacy protocol IEEE 802.15.4. In this survey, we aim at filling this gap by carrying out a performance analysis and thorough discussions of the main features and enhancements of IEEE 802.15.4e. We also provide a literature survey concerning the already proposed add-ons and available tools. We believe this work will help to identify the merits of IEEE 802.15.4e and to contribute towards a faster adoption of this technology as a supporting communication infrastructure for future industrial scenarios.

Index Terms—IEEE 802.15.4e, Wireless Sensor Networks, survey

1 INTRODUCTION

Every century had a dawn and rule of a technology. Nowadays, we are witnessing an unprecedented ubiquity of mobile smart devices, fueled by the gigantic advancements in the fields of microelectronics, information and communication technologies, which have effectively shaped human life in several aspects.

This is an era of technical-industrial revolution, where the world moves towards a paradigm of heightened pervasiveness and ubiquity - the *Internet of Things* (IoT), in which every device will be interconnected and will be performing appropriate and cooperative actions, eventually leading advancements towards smart homes, smart buildings and even smart cities.

Naturally, Wireless Sensor Networks (WSN) emerged as one of the most prominent networking infrastructures to support this paradigm. WSN has embedded its roots in several application scenarios from monitoring natural phenomena like volcanoes and glaciers [1], to monitoring civil infrastructures like bridges and roads [2], [3]. In the field of medicine, for instance Body Sensor Networks [4] have been efficiently used for health monitoring and have not opted out of this momentum. With an ever increasing interest in the adoption of wireless sensing and actuating technologies, we move towards the Industry 4.0 paradigm [5], that converges IoT, Cyber Physical Systems (CPS) and

Cloud technologies to the factory floor. Although there are several IoT enabling architectures [6], [7], [8] that can help in achieving an energy efficient industrial communications, the communication requirements of these time critical processes demand improved *Quality of Service* (QoS) in terms of reliability, timeliness and robustness [9]. These increasingly stringent requirements on the communication protocols have been traditionally addressed by proposing external mechanisms and add-ons to the IEEE 802.15.4 [10], [11]. Therefore, to address the overgrowing demands of the industrial domain and emerging CPS systems for low-power, low-range, and robust wireless communication, *The Institute of Electrical and Electronics Engineers Standards Association* (IEEE-SA) published the IEEE 802.15.4e amendment during the fall of 2012 [12], aiming at enhancing and extending the functionalities of the IEEE 802.15.4-2011 protocol [13].

The enhancements consist of several MAC behaviors, which besides providing deterministic communication are also designed to support multi-channel frequency hopping mechanism, such as in the case of the Deterministic and Synchronous Multichannel Extension (DSME) and Time Slotted Channel Hopping (TSCH). There are also other MAC behaviors like the Low Latency Deterministic Network (LLDN), which uses Time Division Multiple Access (TDMA) to provide timing guarantees. DSME and TSCH were recently incorporated into the revised version IEEE 802.15.4 - 2015 [14] which was released in the mid of 2016. Nevertheless, the current standard specification left several issues open for investigation, including the analysis of the protocols under different settings, scheduling of flows in time-frequency domains, delay bound analysis, to name a few. For example, network planning is needed to correctly assess the requirements of the network in terms of storage and network bandwidth. To achieve this, modeling the fundamental performance limits of such networks is of great importance to understand their behavior under worst-case conditions. In this paper, we address this issue and we present a comprehensive study of those aspects. Importantly, this paper aims at providing a thorough and intensive walk-through of the standard, towards understanding its features and performance improvement in comparison with the IEEE 802.15.4-2011 protocol. We also carry out a state of the art survey to explore the available protocol implementations and tools. To summarize, the contributions of this paper are four-fold:

- First, we provide a comprehensive overview of the

time-critical MAC behaviors of the IEEE 802.15.4e standard protocol, with an emphasis on real-time issues and performance.

- Second, we provide a literature review and a state of the art survey that includes the latest proposals and enhancements
- Third, we present a thorough performance evaluation study of these different behaviors including their formal modeling with network calculus, and we investigate their performance limits under different configurations.
- Fourth, we discussed future research works and directions for the MAC behaviors of the IEEE 802.15.4e standard.

The paper is organized as follows. In the following Section, we provide an outlook to IEEE 802.15.4, which is followed by a brief technical overview of IEEE 802.15.4e. In Section 3, we discuss the temporal behaviors of the various time critical MAC protocols introduced in the IEEE 802.15.4e standard. We discuss all the main enhancements provided and their possible application scenarios. We provide an overall performance analysis in Section 4 and then we provide a state of the art literature survey in Section 5. In Section 6, we overview the implementations and tools available for the standard. We conclude with a discussion of open challenges and future research ideas.

2 AN OVERVIEW OF IEEE 802.15.4E

There are several wireless communication protocols that support various kinds of applications like video, voice and general data communications. Each of these protocols set a trade-off between properties such as throughput, latency, energy efficiency and radio coverage targeting well defined application scenarios. Wireless Sensor Networks usually do not impose stringent requirements in terms of bandwidth, but they require minimized energy consumption so that the overall network lifetime is prolonged. Meeting the QoS requirements such as energy efficiency and timeliness is amongst the main objectives of WSN protocols and technologies.

2.1 IEEE 802.15.4 - The LR-WPAN Standard

To accommodate the QoS needs of industrial communication over the last decade, several standards aiming at low-power wireless communications [15], [16], [17] have emerged. A paradigmatic example is the IEEE 802.15.4 [13], first published in 2003 for WPAN (Wireless Personal Area Networks). The protocol defines only the physical and data-link layers, thus a few proposals such as the ZigBee [18] or the RPL [19] protocols followed to complement the communications stack. In the following sections we briefly explain the layers of IEEE 802.15.4, and then in Section 2.2, we will elaborate the enhancements available in IEEE 802.15.4e.

2.1.1 Components of the LR-WPAN

In the IEEE 802.15.4 [13] standard, devices can be classified into Fully Function Devices (FFD) and Reduced Function Devices (RFD). The Fully Function Devices (FFD) encompass all the capabilities such as routing, association and

formation of a network. The PAN coordinator is an FFD that acts as the main controller to which other devices may be associated. It is responsible for the time synchronization of the entire network. Sometimes, a FFD can also act as a Coordinator providing local synchronization services and routing to its neighbors. Every coordinator must be associated to a PAN Coordinator and it forms its own network if it does not find other networks in its vicinity. The Reduced Function Device (RFD) is typically the end node of an IEEE 802.15.4 network. A RFD is intended for applications that are extremely simple, such as a light switch or a passive infrared sensor which are typically synced with a coordinator and are not capable of routing functionality.

2.1.2 Physical Layer

As shown in Figure 1, IEEE 801.15.4 operates in three different frequency bands: 2.4 GHz (with 16 channels); 915 MHz (with 10 Channels) and 868 MHz (with only one channel). The data rate also varies depending on the bands used. the 2.4 GHz band operates with a data rate of 250 Kbps. The 915 MHz and the 868 MHz bands operate at 40 and 20 Kbps, respectively. The physical layer is responsible for the activation and deactivation of the radio transceiver, measurement of the link quality, clear channel assessment and for channel selection.

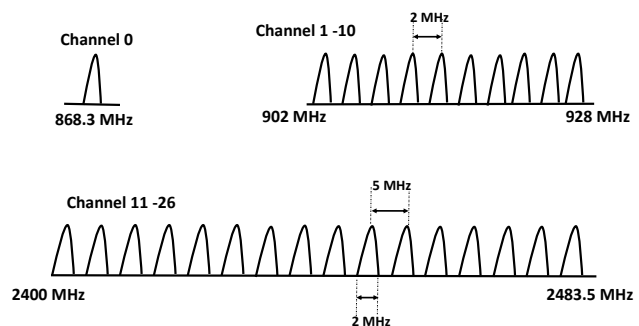

Fig. 1. IEEE 802.15.4 Operating frequency bands

2.1.3 MAC Layer

The MAC layer for IEEE 802.15.4-2011 is designed to work either on beacon enabled or a non-beacon enabled mode. In the beacon-enabled, entire network is synchronized using periodic beacons and is supported by a structure denoted as the superframe (Figure 2). It consists of an active period, where data transmission occurs and an inactive period during which the device enters the sleep state to save energy. The active period is divided into the Contention Access Period (CAP) and the Contention Free Period (CFP). During the CAP, the nodes in the network contend to access the channel using slotted CSMA/CA (Carrier Sense Multiple Access with Collision Avoidance). Whereas, the CFP is equipped with 7 Guaranteed Time Slots (GTS), which are used by nodes that require guaranteed bandwidth.

2.2 Relevant Enhancements Proposed in IEEE 802.15.4e

The IEEE 802.15.4e [12], was proposed as an amendment of the legacy IEEE 802.15.4-2011 standard, to satisfy the

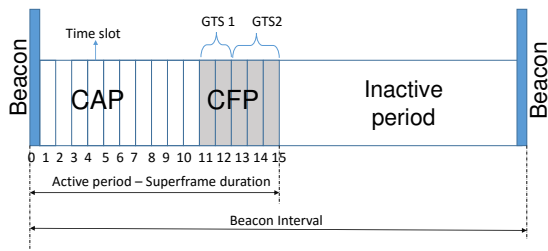

Fig. 2. Superframe structure of the IEEE 802.15.4

requirements of emerging IoT applications, particularly in the industrial domain. The IEEE 802.15.4e only provides enhancements to the MAC sub-layer leaving the physical and security layers untouched. Akin to its predecessor, the IEEE 802.15.4e sets the encryption algorithm for cyphering the data for transmission, but the standard does not specify any particular authentication policies to be implemented.

The IEEE 802.15.4e defines five MAC behaviors, instead of following a more conservative “one-size-fits-all” strategy. Hence, it improves its flexibility in accommodating different kinds of application requirements. In general, these new MAC behaviors are quite different from the ones considered in the legacy IEEE 802.15.4-2011. From the proposed MAC behaviors, the Deterministic Synchronous Multichannel Extension (DSME) is perhaps the closest to the legacy protocol, but nonetheless it brings significant enhancements to the IEEE 802.15.4 beacon-enabled mode by implementing multi-channel frequency hopping and Group Acknowledgments. The other MAC behaviors present far more substantial changes. The Time Slotted Channel Hopping (TSCH) uses fixed size TDMA timeslots and multi-channel hopping. The Asynchronous Multi-Channel Adaptation (AMCA) is perhaps the one that most resembles a non beacon enabled mode in an IEEE 802.15.4 network. On the other hand, the Low Latency Deterministic Network (LLDN) uses a Time Division Multiplexing Access (TDMA) approach to support deterministic traffic.

The various enhancements provided by IEEE 802.15.4e are discussed next:

- **Multichannel Access:** One of the main disadvantages of the original IEEE 802.15.4-2011 was the lack of multichannel access. Multichannel access predominantly helps in mitigating performance degradation due to the interference in the network. The legacy standard only supports a single channel for communication, restricting the capability to accommodate large number of nodes without contention, and therefore deteriorating its network performance, overall delay and throughput. In contrast, some MAC behaviors of IEEE 802.15.4e, overcome these limitations by supporting multichannel operation at the physical layer for some of its MAC behaviors such as DSME and TSCH. The nodes are given the capability to access the channel either through *channel hopping* mechanisms or *channel adaptation* mechanisms. With channel hopping, the channel hopping sequence is statically predetermined in advance. Conversely, with channel adaptation, the

PAN-Coordinator has the ability to allocate different channels for data transmission, based on the respective channel quality.

- **Information Elements (IE):** Information Elements is a concept already defined in the original IEEE 802.15.4 standard; however, it has been further extended in the IEEE 802.15.4e with additional functionalities. Apart from the header and management layer based Information Elements used in IEEE 802.15.4, unique IE have been introduced to support the various MAC behaviors. For example the Information Element for a DSME-enabled network, carries the superframe specification such as the number of superframes in a multi-superframe, number of channels, time synchronization specification, Group Acknowledgment and channel hopping specifications. The IE of TSCH does not incorporate superframes, multi-superframes or Group Acknowledgment specifications but it carries relevant information such as timeslot length, timeslot ID or channel hopping sequence.
- **Low Latency and Low Energy:** The IEEE 802.15.4e protocol provides an improved support for low latency communications, more suitable for industrial control applications, still providing a trade-off between latency and energy efficiency. IEEE 802.15.4e allows devices to operate at a very low duty cycle and also provides deterministic latency, which is a main requirement for time-critical applications. To accommodate Low Energy requirements the non beacon enabled MAC behaviors such as AMCA and the transmissions in the CAP region of the beacon enabled MAC behaviors such as DSME are supported by Low Energy mechanisms. The amendment specifies two Low Energy mechanisms based on the latency requirements of the applications: *Coordinated Sampled Listening* (CSL) is usually used for applications with very low latency requirements. In CSL-enabled receiving devices, the channel(s) are periodically sampled for incoming transmissions at low duty cycles. The receiving and the transmitting devices coordinate with each other to reduce the overall transmitting overhead; *Receiver Initiated Transmissions* (RIT) mechanisms are used for latency-tolerant applications (i.e., tolerating latency of more than 10 seconds). The RIT mode supports applications which run on low duty cycles and low traffic load. It is also applicable for regions like Japan, where consecutive radio transmissions is limited by national regulations.
- **Multi-purpose Frames:** The frame formats of all the MAC behaviors in IEEE 802.15.4e are based on peculiar features of each MAC behavior and its targeted application. The DSME MAC behavior for instance, supports applications where determinism and scalability are fundamental. The MAC frame format of DSME thus supports guaranteed timeslots with multi-channel capability. It also can provide features such as Group Acknowledgment to reduce the overall delay for several GTS based transmissions. The LLDN MAC behavior supports applications that

require very high reliability. The frame format of LLDN, therefore provides provisions for retransmission of frames using separate uplink timeslots and Group Acknowledgment (G-ACK) to acknowledge several frames using a single ACK frame, thus maintaining low latency and high reliability in a network.

- **Enhanced Beacons:** Enhanced Beacon (EB) is a revision of the standard beacon format that is used in IEEE 802.15.4-2011 networks. It provides greater flexibility and it is used to provide application-specific beacon content to the DSME and TSCH MAC behaviors. An EB can be differentiated from the legacy beacon by the frame version information issued by the PAN coordinator. EB carries information on whether TSCH/DSME and Low Energy (LE) are enabled and information about the respective channel hopping sequences.
- **MAC Performance Metrics:** The IEEE 802.15.4e amendment supports a feedback to the upper layers on the network performance via "*MAC performance metrics*". These metrics provide information on the link performance (quality of the channel), which may help the network layer to take efficient routing decisions, thereby reducing the overall power consumption and latency of the network. The feedback information includes: (i) the number of transmitted frames that required one or more retries before acknowledgment; (ii) the number of transmitted frames that did not result in an acknowledgment after a duration of *macMaxFrameRetries*; (iii) the number of transmitted frames that were acknowledged properly within the initial data frame transmission; and (iv) the number of received frames that were discarded due to security concerns.
- **Fast Association:** In IEEE 802.15.4, the association procedure encompasses a significant delay. This is mostly due to the fact that in IEEE 802.15.4, the device must wait till the end of *MAC response Wait Time* before requesting the association data (e.g., short address) from the Coordinator. To address this issue, the IEEE 802.15.4e introduces a Fast Association mechanism, under which the device requests for association from the PAN Coordinator. If resources are available, the PAN coordinator allocates a short address to the device. It also sends a association response which contains the assigned short address and status indicator for a successful Fast Association.
- **Group Acknowledgment:** The DSME and LLDN MAC behaviors of IEEE 802.15.4e support Group Acknowledgment (GACK). Several successful transmissions can be acknowledged using a single GACK either within the adjacent beacon interval or as a separate Group Acknowledgment frame. GACK can be issued by the PAN coordinator only for a dedicated timeslots in case of LLDN or a guaranteed timeslot in case of DSME. This greatly improves the efficiency by reducing the overall waste of bandwidth with multiple acknowledgments. In addition, there is a provision to acknowledge all the retransmissions in the network, thus saving time and energy. However, failure of a GACK can result in losing the entire ac-

knowledgment data. This can prolong the waiting for an alternative GACK to be issued in a new timeslot.

3 TIME CRITICAL MAC BEHAVIORS

In this section, we provide an overview of the time-critical MAC behaviors defined in IEEE 802.15.4e standard. The IEEE 802.15.4e provides five different MAC behaviors: Radio Frequency Identification (RFID), Asynchronous Multi Channel Adaptation (AMCA), Deterministic Synchronous Multichannel Extension (DSME), Low Latency and Deterministic Networks (LLDN) and Time Synchronous Channel Hopping (TSCH).

We start with an overview of the two non real-time MAC behaviors namely the RFID and ACMA, before describing in detail the time critical MAC behaviors: that is, DSME, TSCH, and LLDN, which are the focus of this paper.

3.1 Brief overview of RFID and AMCA

RFID [20] is one of the most popular technologies used for location tracking and 'item and people' identification. RFID integration with wireless sensor networks have been used in global commercial markets like Walmart [21] for tagging and identifying products. It also has been employed in the field of tele-medicine [22] for security and privacy purposes. In the Blink mode of a RFID-based IEEE 802.15.4e network, transmitters communicate with the receivers using their 64-bit address and an optional payload data.

The Blink mode in RFID allows the device to communicate its ID, an *Extended Unique Identifier* - EUI-64 source address, and an additional payload data to devices with which they communicate. Devices can connect with each other without any prior association or acknowledgment. The Blink frame can be used for "*transmit only*" purpose and it coexists with other devices in the network. The Blink frame can be rejected during the frame processing if the devices are not interested in Blink enabled communications. Blink uses a multipurpose "*minimal*" frame that consists only of the header fields necessary for their operation. This helps in reducing the overall power consumption in the network.

In dense sensor network applications such as structural health monitoring [23], a single channel approach does not have the capability to handle such densely populated networks. The variance of the channel quality is usually large in these dense networks [24], leading to link asymmetry and thus jeopardizing the application performance. Multichannel adaptation is a possible method to overcome link asymmetry. The AMCA (*Asynchronous Multi Channel Adaptation*) mode can be enabled for the non-beacon enabled mode of IEEE 802.15.4e networks. In the *synchronous multi-channel adaptation mechanism*, two devices cannot communicate using a common channel. In the case of AMCA, the device selects a *mac Designated Channel* based on the channel link quality. In order to switch channels for either listening or transmitting, a channel probe is requested by the coordinator of ACMA during an active scan. The channel probe always probes all the available channels in the network and switches the transmission to a better channel in case of a poor quality transmission.

In contrast to AMCA and RFID, the three other MAC behaviors are designed for time critical applications which provide deterministic guarantees and improved robustness. In what follows, we provide a comprehensive overview of the three remaining MAC behaviors.

3.2 DSME

3.2.1 Application Overview

The Deterministic Synchronous Multichannel Extension (DSME) MAC behavior targets applications with QoS requirements such as deterministic latency, high reliability and scalability. Industrial automation and process control applications are well known for being very sensitive to the loss of data, considering the criticality of exchanged information [25]. On the other hand, health monitoring systems present stringent time constraints, such as guaranteeing very short end-to-end latency (e.g. <10ms) requirements [26]. In addition, several WSNs applications like outdoor monitoring (as those reported in [27], [28]) have a need to be deployed in a higher density, and thus scalability becomes a major concern. DSME aims at providing solutions for applications with this kind of stringent QoS requirements. To address this objective, DSME provides several enhanced features to the native IEEE 802.15.4, namely: (1) multi-superframe; (2) CAP reduction; (3) Group Acknowledgment; (4) distributed beacon scheduling and (5) Channel diversity modes to address the non-functional properties mentioned above. We present these features in detail in the next sections.

3.2.2 Multi-Superframe

The PAN coordinator of a DSME network defines a cycle of repeated superframes called the *multi-superframe structure* (Figure 3). Similar to IEEE 802.15.4, a superframe in the multi-superframe structure will have a Contention Access Period (CAP) and a Contention Free Period (CFP). In a Multi-superframe, a single common channel is utilized for a successful association, it is also used to transmit the EB frames and the frames transmitted during the CAP. The number of superframes that a Multi-superframe should accommodate is determined by the PAN coordinator based on the number of data packets meant to be transmitted within the time interval, and is conveyed to the nodes through an Enhanced Beacon (EB). Multi-superframe due to its multi channel features incorporated in it helps in the formation of peer to peer topologies like a mesh.

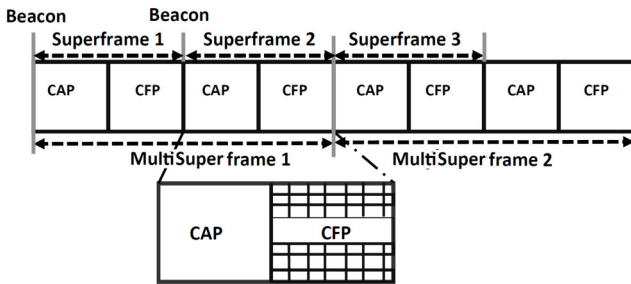

Fig. 3. Multi-superframe structure of DSME

The standard defines the structure of the superframe by the values of Superframe Duration (SD), Multi-superframe

Duration (MD) and the Beacon Interval (BI) which is the time period between every beacon. The Multi-superframe Duration is a new parameter introduced in DSME, it provides the length of all the individual superframes within the multi-superframe. These parameters are defined in the following equations:

$$MD = aBaseSuperframeDuration \times 2^{MO} \text{ symbols} \quad (1)$$

$$\text{for } 0 \leq SO \leq MO \leq BO \leq 14$$

$$BI = aBaseSuperframeDuration \times 2^{BO} \text{ symbols} \quad (2)$$

$$\text{for } 0 \leq BO \leq 14$$

$$SD = aBaseSuperframeDuration \times 2^{SO} \text{ symbols} \quad (3)$$

$$\text{for } 0 \leq SO \leq BO \leq 14$$

In the previous definitions, *BO* is the *MAC Beacon Order* and it defines the transmission interval of a beacon in a superframe. *MO* is the *MAC Multi superframe Order* and it represents the beacon interval of a multi-superframe. *aBaseSuperframeDuration* is the minimum duration of a superframe corresponding to the initial order of the superframe (i.e, $SO = 0$). This duration is fixed to 960 symbols (a symbol represents 4 bits) corresponding to 15.36 ms, assuming a bit data rate of 250 Kbps in the 2.4 GHz frequency band. The total number of superframes and multi-superframes in a DSME network can be determined by $2^{(BO-SO)}$ and $2^{(BO-MO)}$, respectively.

As an example, let us consider the case where $BO = 3$, $MO = 3$ and $SO = 2$. In this case, there are two superframes that are combined in a single multi-superframe, as illustrated in Figure 4. The DSME GTSS in the available channels are shown as grids in the CFP region for the aforementioned parameters. The horizontal axis of the grid represents the time, and the vertical axis of the grid represents the frequency. This means that several GTSSs can be allocated at a same time but on different frequencies (i.e., channels).

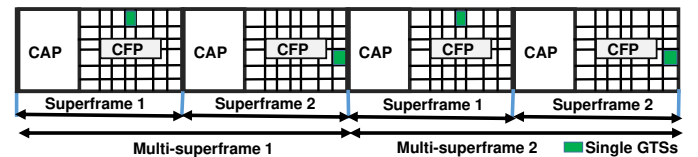

Fig. 4. Superframe structure with $BO=3, MO=3, SO=2$

The CFP region of the IEEE 802.15.4-2011 enabled superframe comprised seven GTSSs. DSME enhances the functionality of the traditional GTSS by extending its number using the multi-superframe's multi-channel communication. This enables the protocol to select better channels based on link quality and to accommodate higher number of transmissions, and thus to increase the overall reliability and scalability. Figure 5 gives an example, where 4 transmissions have to be handled in the CFP region. DSME with 3 channels is taken for comparison with the legacy IEEE 802.15.4. It can be seen that the legacy IEEE 802.15.4 accommodates 4 timeslots for 4 transmissions, whereas DSME requires only two, additionally, it provides more timeslots to be occupied by other nodes in the network, thus increasing the overall

scalability. In IEEE 802.15.4 there was single point of failure problem because beacon scheduling and slot allocation were carried out in a centralized fashion by the PAN-C. When there is a problem in a root of a network, the entire network collapses due to the lack of capability for selecting an alternative route. This has been mitigated in DSME by distributed beacon scheduling, it provides the capability for peer to peer communications like mesh networks which can utilize alternative routing paths to reach a destination.

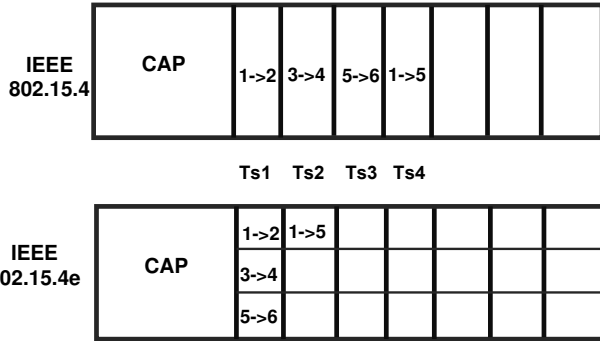

Fig. 5. Comparison of DSME GTSs with the legacy GTS

3.2.3 CAP Reduction

It is possible for the PAN Coordinator to reduce the size of the CAP by enabling it only in the first superframe of a multi-superframe, this technique is called CAP reduction. In this way, the remaining superframes only present a longer CFP (Figure 6). It radically increases the number of DSME GTSs that are allocated to the neighboring nodes, while saving energy, since there is no need for a node to stay active during a CAP if no transmissions are expected to occur. CAP reduction is a very suitable add-on for highly dense networks with stringent QoS requirements in terms of delay and reliability.

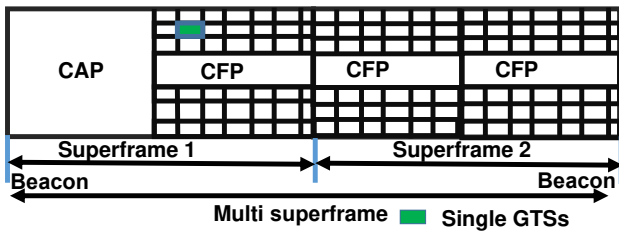

Fig. 6. CAP Reduction technique in DSME

3.2.4 Group Acknowledgment

Another important functionality of the DSME GTS is its Group Acknowledgment (GACK) feature. This mechanism provides the capability of sending a single acknowledgment for all guaranteed transmissions within the same multi-superframe. The GACK reduces the latency and energy consumption by combining several acknowledgments into a single group acknowledgment.

The Coordinator announces the GACK feature using an Enhanced Beacon with a *mac GACK Flag*, it is defined using a GACK element (Figure 7). In addition, a single Group

Acknowledgment is sent by the coordinator to acknowledge every DSME GTSs transmissions in the CFP region. Group Acknowledgment IE indicates the reception status for the set of GTS data frames it acknowledges and new slot allocations (for the retransmission of failed GTS transmissions). The GACK element carries the *bitmap* which indicates the state of transmissions in the guaranteed timeslots. *GACK Device List* is exclusive for DSME, and it indicates the devices for which the guaranteed timeslots are allocated in their respective CFP region. The *GACK Index field* is also DSME exclusive, it specifies the start every GTS for the allocated nodes in an order accordance to the *GACK device list*.

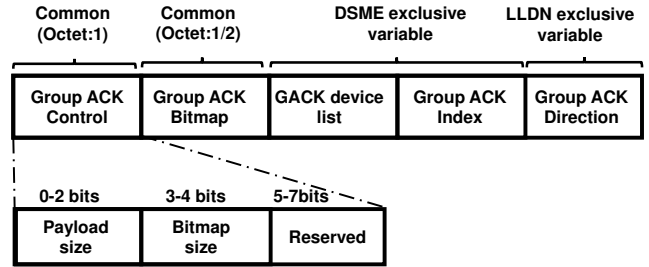

Fig. 7. GACK element of DSME

In Figure 8, we consider that the shaded portion in the grid of the first CFP and the second timeslot of the adjacent superframe as the DSME GTSs allocated for retransmission. A single GACK (fourth timeslot of the second superframe) can be given for all these transmissions. Group Acknowledgment saves a lot of power and time that is spent for individual acknowledgments. In case of a failed transmission, a new DSME GTS will be assigned to carryout the process.

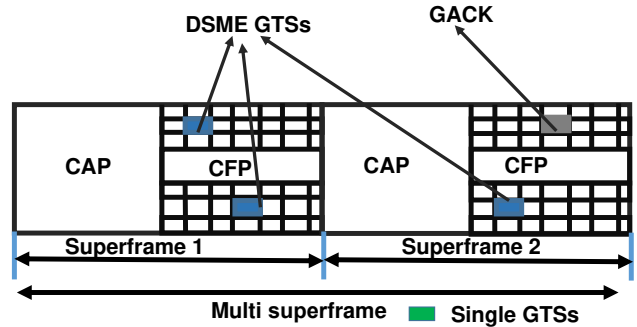

Fig. 8. Group Acknowledgment in DSME

3.2.5 Beacon Scheduling

In order to build more complex networks topologies such as mesh, it is mandatory to carryout efficient beacon scheduling to avoid interference and collisions. In a DSME network, all the devices are time-synchronized using the values of the *Timestamp* field of the received beacons from the device they are associated with, thus maintaining global time synchronization in the PAN. When a node wants to join a network, it uses an `MLMESCAN.request` primitive to initiate scanning over all the available channels in the network. During this scanning process, the joining node searches for all coordinators transmitting Enhanced Beacon

frames. The neighboring devices send their beacon schedule information to the new joining device by transmitting an Enhanced Beacon. This beacon schedule is updated as a bitmap sequence. The new joining device searches for a vacant beacon slot, and if available, will claim it to use it for sending its own beacons.

In the CAP of DSME and the shared timeslots of LLDN, there is a risk of a beacon collision as two or more devices are trying to compete for the same beacon slot number due to the hidden-node problem. Beacon scheduling procedure cannot completely eliminate this risk. In Figure 9, let us consider that device D and E are willing to join the network. These devices receive the beacon bitmap from their neighboring device A. Now there is a possibility of collision when both D and E want to use the same vacant beacon slot within the CAP. This is called the hidden node problem. This is because devices D and E are hidden from each other and they cannot listen to each others transmissions.

This is solved in DSME via the DSME-Beacon allocation notification command which solves the contention by prolonging the received DSME-beacon allocation commands based on the MAC performance metrics. Every beacon frame has its own allocation superframe duration number ($SDIndex$) for identification. If both devices D and E send a DSME-Beacon allocation notification command with same $SDIndex$ value, device A which is common to both D and E determines which device should be given the higher priority based on MAC performance metrics. As such, the conflict is resolved.

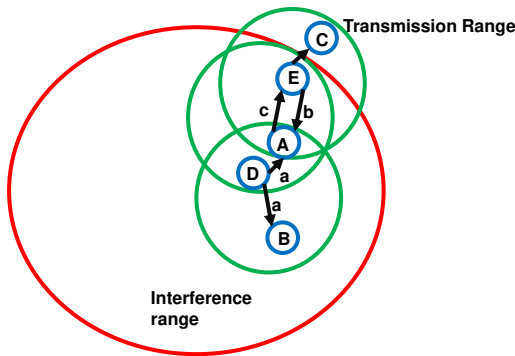

Fig. 9. Hidden node problem in DSME

3.2.6 Channel Diversity

When heterogeneous RF devices having the same RF spectrum are present in the same network, it causes significant interference and failure of transmissions [29], thus affecting the overall reliability of the network. Channel diversity is mechanism helps in overcoming this aforementioned issue.

The DSME MAC protocol defines two channel diversity mechanisms: (1) *channel adaptation* and, (2) *channel hopping*. The kind of channel diversity mechanism under which the DSME operates will be conveyed by the PAN Coordinator through a DSME PAN descriptor Information Element (IE) in its Enhanced Beacon.

In *channel adaptation*, the PAN coordinator has the capability to allocate the DSME guaranteed timeslots either in a single channel or through different channels to an end

device. This decision is influenced by the link quality of the current channel. The link quality of the channel is conveyed to the PAN coordinator through the MAC performance metrics which was discussed in Section 2. The PAN coordinator also possess the ability to deallocate a specific DSME GTSS if the link quality of an allocated DSME GTSS becomes degraded.

Channel adaptation in DSME-GTSS is illustrated in Figure 10. Devices 0, 1 and 2 use channel 1 during the timeslots 1 and 2, then they later switch to channel 4 during timeslots 5 and 6. This switching of channels can be result of link quality degradation or some performance metric specified by the coordinator.

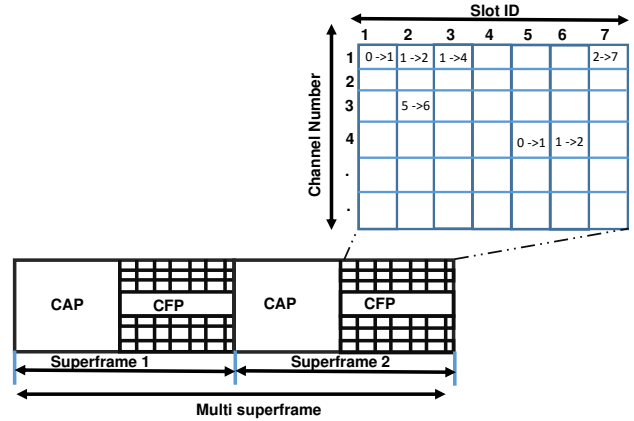

Fig. 10. Channel adaptation in DSME

Channel hopping is a methodology by which, several devices hop over different channels in a predefined channel order. Channel hopping is a well established technique that has been used in radio communication systems for decades. In radio systems, many receivers can select a channel from a predefined set to receive the required broadcast information [30]. In DSME, the guaranteed timeslots hop over a predefined series of channels called as the *hopping sequence*. The *channel hopping sequence* is defined by the the upper layers of the standard. This same hopping sequence will be carried out over the entire time frame of transmission. All the devices in the PAN must be time synchronized, so any form of interference is avoided by coordinating the channel usage among devices in the same interference range. In channel hopping, a channel offset is used to provide orthogonality among all devices employing same channel hopping sequence list. In Figure 11, the shaded cells of the grid represent the DSME GTSSs in a CFP, which has a *hopping sequence* that follows a channel offset of 1.

3.3 LLDN

3.3.1 Application Overview

The Low Latency Deterministic Networks (LLDN) MAC behavior targets applications that typically demand robustness because of the critical nature of the data. For instance, LLDN is a suitable MAC behavior for terrain surveying [31], where large geographical areas are surveyed to capture their temporal dynamics. In terrain surveying, more than 100 nodes communicate with a coordinator in a single hop.

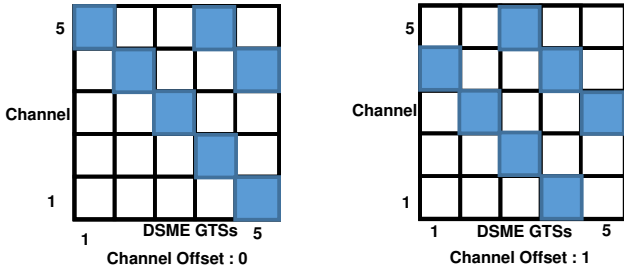

Fig. 11. Channel hopping in DSME

LLDN is a star topology exclusive MAC behavior making it suitable for applications that demand a centralized control.

Several process control applications have a very small round-trip time and the communication has to be carried out in a periodic basis. Fuzzy logic petrinets [32] have been used in the current process control technologies for networking. LLDNs networking techniques provide more determinism in small round-trip communication, thus making them more suitable to support these centralized networks.

We present an overview of some important features of LLDN such as the LLDN Superframe, network topology and its data transfer models.

3.3.2 Network topology

In LLDN, all the nodes are individually connected to a PAN coordinator, thus forming a star topology. LLDN consists of two kinds of devices: (i) devices that can send data to the PAN-C using an uplink (ii) devices that can send and receive data from the PAN-C using bidirectional timeslots. The selection configuration and the number of timeslots are determined by the higher layer.

Figure 12 shows a simple scenario of an LLDN enabled sensor-actuator system connected to a single PAN coordinator through star topology. The sensors will be able to send data as an uplink to the PAN Coordinator. The nodes with the actuator on the other hand, can both perform an uplink as well as receive actuating signals from the PAN Coordinator as a downlink.

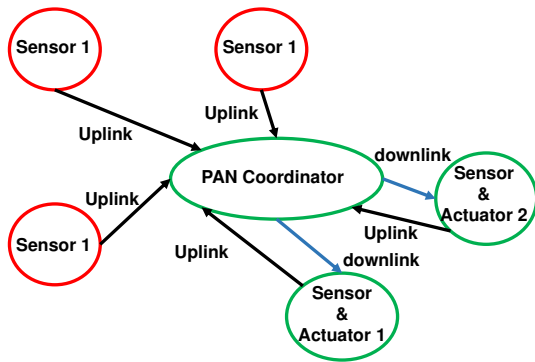

Fig. 12. LLDN network topology

3.3.3 LLDN Superframe

The LLDN PAN Coordinator uses Low Latency superframes (LL frames, as shown in Figure 13) for transferring data.

This superframe type is composed of four parts: *the beacon, uplink timeslots, management time slots and the bidirectional timeslots*. LLDN MAC behavior exclusively supports the beacon-enabled communication of IEEE 802.15.4e.

The beacon occupies the start of every superframe and it provides time synchronization for the entire network. By default, an LLDN superframe comprises of 20 timeslots. The beacon is immediately followed by uplink and downlink *management timeslots*, which use slotted CSMA/CA mechanism for channel access to send the management information. Next in the superframe, follow *the uplink timeslots* which are used in unidirectional transmission (to the coordinator). These timeslots are reserved for dedicated nodes assigned by the PAN coordinator. A part of these time slots are reserved as retransmission timeslots. Finally, the *bidirectional timeslots* are used for the communication from the PAN coordinator to the nodes. They can also be configured as uplink timeslots. The direction of these bidirectional slots is sent through an Enhanced Beacon which is issued at the Configuration setup phase of the network.

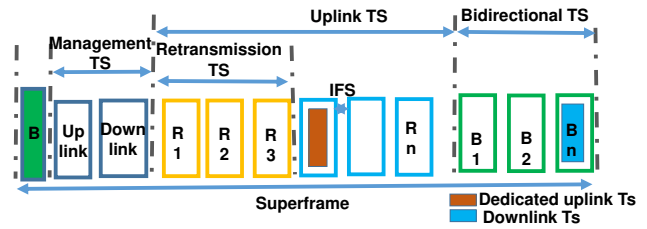

Fig. 13. Superframe of LLDN - LL frame

3.3.4 LLDN transmission states

The network setup for every node in an LLDN network follows three transmission states: Discovery, Configuration and Online.

The network setup begins in the Discovery state. In this phase the superframe is composed of a beacon, two management timeslots (one downlink and one uplink). The device that wants to join the network, scans the available channels for an LLDN PAN coordinator, which will be broadcasting Enhanced Beacons indicating the Discovery state. If the scanning device wants to join the PAN Coordinator, it uses an uplink management timeslot to send a join request to the PAN Coordinator. In the uplink management timeslot, nodes rely on CSMA/CA to access the channel. This uplink is used to transmit the discovery response frame, which will have the current configuration of the device. When the PAN Coordinator receives a message from a node, it responds with an acknowledgment. This entire process should happen within *macLLDNdiscoveryModeTimeout* which is 256 seconds. If successful, the PAN Coordinator will switch its state to Configuration.

The Configuration step can happen either after the discovery of a new device or the failure to discover a device. In the Configuration state, the superframe changes again, comprising a beacon, two management timeslots, one downlink and one uplink. When a device receives a beacon indicating the Configuration state, it will send a Configuration Status frame to the LLDN PAN coordinator.

The Configuration Status frame contains the current configuration of the device such as the MAC address, required timeslot duration, uplink/downlink data communication and the assigned timeslots. The device will keep on sending the Configuration Status frame till the end of the Configuration Request state or until the moment it receives a Configuration Request frame. The Configuration Request frame is sent by the PAN Coordinator and it contains the new configuration for the device. The configuration request frame specifies the existence, length of the management timeslots and the directions of the bidirectional frames. An acknowledgment is sent to the LLDN PAN coordinator when the device receives the command of the Configuration Request frame.

Finally, after the initial setup states, data transmission can now occur between the PAN coordinator and the device. Once the Configuration Request frame has successfully been acknowledged by the new node, the Online state begins. The superframe configuration is changed to accommodate a beacon and several timeslots (both uplink and downlink) depending on their respective configuration. LLDN facilitates retransmission in case of failure and collisions. It provides Group Acknowledgment (GACK) feature similar to the one in DSME. GACK can be used in the uplink timeslots to acknowledge several retransmission frames. When a new device wants to join the network after the Online state, it scans all the available channels until it finds a LLDN PAN Coordinator issuing EBs indicating the Discovery state.

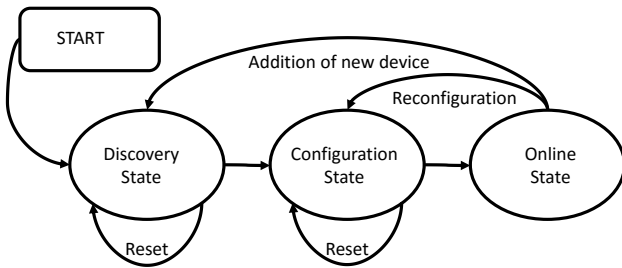

Fig. 14. Configuration states of LLDN

3.3.5 Data transfer modes

To a Coordinator

When a device wants to send data to a PAN coordinator, it waits till the reception of a beacon. At reception, the device synchronizes with respect to the configuration received. The device has the option to either use a dedicated timeslot or a shared timeslot. The data frame is transmitted without contention in the case of a dedicated timeslot. In some cases, more than one device can be assigned to a single timeslot. These are called *shared group timeslots*. If the device transmits its data frame in a shared group timeslot (not the slot owner), then the data frame is transmitted using slotted CSMA/CA. The dataflow from an uplink dedicated timeslot and uplink shared timeslot is depicted in Figure 15.

To a New Device

When the LLDN PAN coordinator wants to transfer data to an LLDN device, a bidirectional timeslot is assigned for transmission. The direction of the bidirectional timeslots

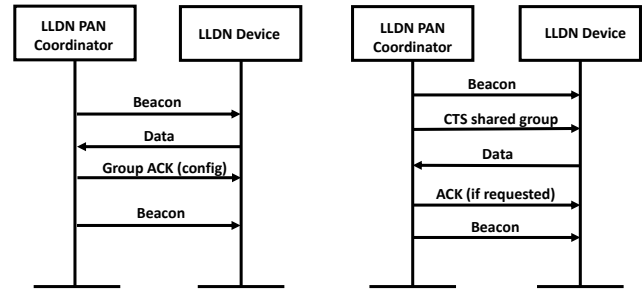

Fig. 15. Data flow for uplink dedicated timeslot (left) and shared timeslot (right)

(either uplink or downlink) is set during the Configuration phase of the setup. The LLDN PAN coordinator can configure the bidirectional timeslots to downlink and use them entirely for data transmission to the nodes. Any data transmission from the LLDN PAN Coordinator is carried out without contention. The device sends an acknowledgment upon a successful data reception. Figure 16 gives the data flow diagram from the PAN coordinator to an LLDN device.

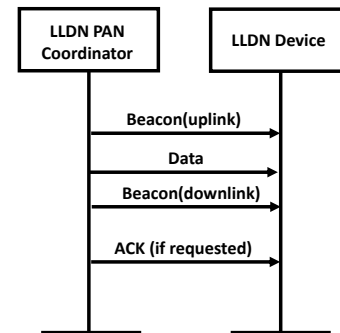

Fig. 16. Data flow to a new device

3.4 TSCH

3.4.1 Application Overview

The Time Slotted Channel Hopping (TSCH) MAC behavior provides very high reliability and time critical assurances. TSCH is a suitable candidate for implementing sensor-actuator networks in oil and gas industries which are defined as safety critical [33], as the prime concern can be human and environmental safety. These industries are prone to interferences that affect the functionality of wireless devices. TSCH supports the *Frequency Hopping* mechanism, which greatly improves the reliability of the network by effectively mitigating the effects of interference and multi-path fading at a considerable scale.

Time-slotted communication links greatly reduce the unwanted collisions that can lead to catastrophic failures. Data centers monitoring [34] are also prone to collisions because the network has to accommodate dense sensors and is tightly coupled with high network traffic increasing the chances for collision in the network. TSCH can help accommodating a dense network, at the same time, maintaining stringent time constraints using fixed length timeslots and

multichannel access. TSCH uses TDMA based slotframes, thus facilitating collision-free transmissions.

In the next sections, we present some of the most interesting features of TSCH, such as slot frames, channel hopping, fast association, time-node synchronization and TSCH CSMA/CA.

3.4.2 Slotframes

In TSCH, the superframe concept used in DSME, LLDN and its parent standard IEEE 802.15.4 has been replaced with the concept of *slotframes*. Every slotframe is a collection of timeslots. Communications in each timeslot can be either contention (i.e., using CSMA-CA) or non contention based. Every timeslot accommodates a transmission and an eventual acknowledgment. The slotframe size is defined by the number of timeslots in the slotframe. Every slotframe repeats in cyclic periods, thus forming a communication schedule. For identification, a slotframe handle is associated at the start of every slotframe. TSCH is topology independent, supporting wide variety of topologies from a star to a full mesh.

Figure 17 shows a three time-slotted slotframe. In this example, the slotframe repeats every three timeslots. Let us take 3 devices, A,B,C; in timeslot 0, device A transmits its data to B and during 1, B transmits to C and during timeslot 2 the devices remains in an idle state. This repeats in the same order for every three timeslots. Every timeslot in TSCH PAN has an Absolute Slot Number (ASN) which increases globally and is used to compute the channel in which a pair of nodes communicate.

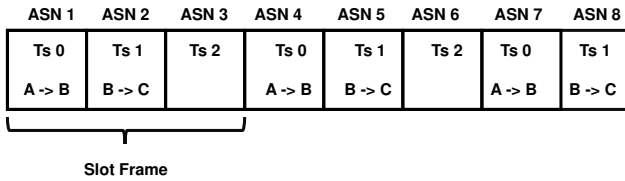

Fig. 17. TSCH slotframes

TSCH provides concurrent slotframes to support concurrent transmissions, these are called *multiple slotframes*. These slotframes can have different communication schedules. A multiple slotframe is established by configuring different communication schedules and connectivity matrices to work in parallel. All slotframes are aligned to timeslot boundaries. For example, in Figure 18, it can be seen that timeslot 0 of every slotframe is projected back to ASN = 1. The PAN coordinator holds the responsibility to align slotframes in a multiple slotframe.

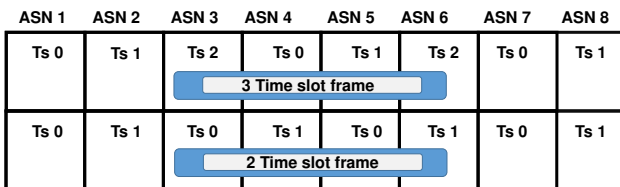

Fig. 18. TSCH multi-slot frames

3.4.3 Channel Hopping

Unlike DSME which has channel diversity mechanisms, the multichannel communication of TSCH completely relies on channel hopping. TSCH can utilize 16 channels for communication which are defined by a channel offset, an integer value ranging from [0-15]. In TSCH, the link between two nodes is defined by [n, channel offset]. This is a pairwise assignment of the timeslot "n" where the two nodes communicate and their respective offset. The frequency used for communication can be defined by f .

$$f = F[(ASN + channel\ Offset)\%N_{channels}] \quad (4)$$

In Equation 4, $N_{channels}$ define the number of channels under usage for the current network as it is not mandate to utilize all the 16 channels. Channels can be left out to improve energy efficiency or if the channel quality is deteriorated. As previously mentioned in 3.4.2, ASN helps in determining the number of timeslots elapsed since the beginning of the network. The function F can be defined as a lookup table. Also from equation 4, it can be noted that a different channel ($N_{channel}$) can be implemented over for the same offset for an incremented ASN, (i.e) the channel hopping mechanism can utilized with the different frequency over the same link.

3.4.4 PAN Formation

When a network is to be established, the PAN coordinator starts broadcasting an Enhanced Beacon (EB) in response to a *MLME BEACON.request* from a higher layer. This action is termed as *Advertising*. The devices that want to connect with the PAN coordinator should be in the broadcast range of the PAN coordinator. The EB contains time information, channel hopping information, timeslot information and initial link information. *Time information* provides the specific time period at which the nodes should synchronize with the network. *Time slot information* describes the time when data will be transmitted. Lastly, the *Initial link information* gives the time on when to listen to an advertising device and transmit to the same device.

A device wishing to join the network either does active scanning or passive scanning after receiving an *MLME SCAN.request* from a higher layer. After an *MLME-BEACON-NOTIFY.indication*, the higher layer, initializes the slot frame and *Initial link information* available in the Enhanced Beacon. When the device synchronizes with the network, the higher layer changes the device into TSCH mode by issuing a *TSCH MODE.request.Association*.

The devices may also request for additional slot frames and link resources before association. In order to get additional link resources (slotframes and links) the device should undergo a security handshake for authenticating the joining process. After getting associated in a network, the fully functional devices are completely capable of transmitting Enhanced Beacons for synchronizing and adding nodes to the network. The size of the network plays a crucial role in determining the advertising rate and the configuration by the higher layers. These configurations will have a direct impact on the non functional properties such as scalability and power consumption of the network.

3.4.5 Fast Association

Fast association (FastA) is optional for every MAC behavior of IEEE 802.15.4e. To carry out a Fast association, the higher layer of the device posts a *MLME ASSOCIATE.request primitive*, triggering the FastA procedure in the MAC sublayer. The request is sent to the PAN coordinator which acknowledges its reception.

Fast Association removes the wait time duration "*macResponseWaitTime*", which is used for the association process in legacy IEEE 802.15.4. This efficiently reduces association delay. The association request command contains an acknowledgment request, the coordinator confirms it by sending an acknowledgment frame. If the coordinator has sufficient resources, the higher layer allocates a 16 bit address to the device. MAC sublayer then generates a status indicating *FastA successful*. The device can then use the *macShortAddress* for its association within the PAN.

3.4.6 Time and Node Synchronization

Time propagates outwards from the PAN coordinator in a TSCH based network. A communicating device must synchronize its network time with an other device in its vicinity at periodic intervals. Using the neighbor device as a time source/reference, all synchronized devices should have a prior idea where the timeslot begins and where it ends.

Node-node synchronization is also done to ensure connection with the neighboring nodes in a slotframe based network. Time source neighbors keep track of the devices and if they do not receive a request from the device at least once per *keep alive period*, they will send an empty acknowledgment frame to perform acknowledgment based synchronization.

Let us take the example of the network containing a PAN coordinator and two nodes as shown in Figure 19, the PAN coordinator acts as a time keeper of the entire network. Device 1 synchronizes only to the PAN coordinator. The second device time has no influence over the time synchronization of device 1. Whereas the synchronization of device 2 is dependent both on the PAN coordinator and device 1.

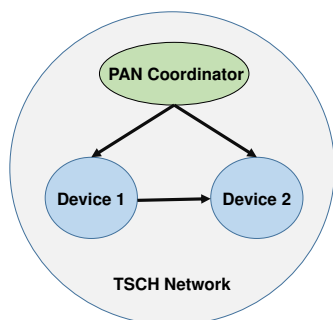

Fig. 19. TSCH- time node synchronization

Synchronization happens whenever a device exchanges a frame with a time source neighbor. To support this there are two methods: either through the time information that is received within an acknowledgment from the receiver or from the arrival time of a frame from the time source neighbor. This is called *Acknowledgment based* and *frame based synchronizations* in a TSCH network.

In *acknowledgment based method*, synchronization is carried out through exchange of data frames and acknowledgments. The receiver calculates the difference between the expected arrival time and the actual arrival time. Then a timing correction information is sent to the transmitting node through an acknowledgment.

Whereas, in the *frame based synchronization*, nodes synchronize to its own network clock, whenever they receive a data frame from a time source neighbor. The receiver calculates the time difference between the expected arrival time and the actual arrival time, and uses this information to adjust its own network clock.

3.4.7 TSCH CSMA/CA

The decision to choose either TSCH mode of the slotted CSMA/CA mode in TSCH is taken by looking into the contents of the *TSCH IE* which is issued during the network formation. When the transmission link is established under slotted CSMA/CA, it performs a *Clear channel assessment* (CCA). If the channel is idle, transmission occurs, else the network waits for the transmission link to reach the destination.

Two kinds of links can be established in TSCH CSMA/CA enabled system, they are the *shared link* and the *dedicated link*. Shared links are used to assign to more than one device during data transmission. When a packet is transmitted using a shared link, it awaits for an acknowledgment. These links are prone to collisions and failures. To reduce collisions, retransmission backoff algorithms are used. The back off window keeps on increasing with every retransmission. At the point of a successful transmission the backoff window is set to the minimum value.

In dedicated links, transmission is more reliable since there is no contention between nodes to occupy the channel. In a dedicated link, the back off window does not change when the transmission is successful, but when the transmit queue becomes empty, the back off window is reset.

4 LITERATURE REVIEW

In this section, we aim at providing a comprehensive literature review which can help the readers to understand the current state-of-the-art, challenges and eventual solutions. The number of comprehensive surveys and tutorial studies based on IEEE 802.15.4e is very limited. Domenico De Guglielmo et al provided the first and only surveys on IEEE 802.15.4e in [35] and [36]. In these surveys, the authors have highlighted the limitations of the IEEE 802.15.4 standard and how the enhancements of IEEE 802.15.4e overcome it. However, despite they provided a performance evaluation of the TSCH MAC behavior of IEEE 802.15.4e, they did not for the other MAC behaviors. In our survey, we consider the worst-case performance evaluation of all real-time MAC behaviors which makes an additional contribution to the state of the art. Today, due to an increasing interest of the academic and industrial communities upon this standard, there is a need of a more complete state of the art survey which covers aspects of the IEEE 802.15.4e, open challenges, as well as the available tools. A thorough performance analysis of the most relevant MAC behaviors is also becoming urgent.

In this section, we provide a detailed literature survey to the community, highlighting the current state of the art of IEEE 802.15.4e. We also identify a set of important enhancements to the standard and provide a comparison between them in Table 1. In the following sections, a thorough performance analysis is presented to identify the trade-offs from a network engineering perspective, potentially helping the network designer to compute the worst-case bounds and carry out sound network planning. We also review the current available tools for network modeling and implementation. We end the paper by identifying the open issues in the state of the art, providing potentially interesting research directions.

4.1 DSME

Wun-Cheol Jeong et al [37] carried out a performance evaluation of DSME, finding that the throughput of DSME MAC protocol is 12 times higher when compared to IEEE 802.15.4 slotted CSMA/CA in a multi-hop, 5x5 square grid device network deployment in a star topology. He also states that the energy consumption under DSME MAC remains almost constant through time, whereas under CSMA-CA it exponentially increases. Using mathematical modeling it has been verified that the throughput increases significantly when CAP reduction is applied to the system.

Junhee Lee et al [38] analyzed the performance of IEEE 802.15.4e DSME MAC Protocol Under WLAN Interference in comparison with IEEE 802.15.4 beacon enabled WSN in terms of Frame Error Rate (FER) and aggregate throughput. It was observed that the FER of slotted CSMA/CA increases when the number of end devices increases. Whereas, FER of DSME MAC remains the same regardless of the number of endpoint devices due to orthogonal DSME-GTS allocation. He confirmed that DSME-enabled WSN tolerates better heterogeneous interference while obtaining the same FER. Complementing this result, he also proved that, DSME manages to maintain a high level of throughput.

Prasan Kumar Sahoo et al [39] provided a new channel access scheme and a beacon broadcast scheme for DSME to avoid the collision in a mobile-dense wireless network. They provide analytical models to measure the data transmission reliability, throughput, energy consumption and success rate probability and compared it with IEEE 802.15.4e. They have devised a new retransmission scheme that helps the network achieve better performance results.

Under DSME MAC protocol, a single Personal Area Network Coordinator (PANC) can associate several slave devices with negligible collisions using fast association. Xuecheng Liu et al [40] developed a technique called Enhanced Fast association (EFastA) by which hundreds of slave devices can associate within 3 MDs (Multi-superframe Duration). He has analyzed the performance of EFastA in terms of network convergence time and mean number of collisions/retransmissions for association.

The feasibility of DSME enabled MAC in a real-time environment was studied by Tuomas Paso et al [41]. The performance of communication system utilizing IR-UWB PHY (Infra Red-Ultra Wide Band PHY) was analytically derived and simulated. It was concluded that, the usage of DSME GTSs slots in the network improves its performance in terms of throughput and end to end packet delivery.

Mukesh Taneja et al [42] in his paper, provided a flexible resource management framework for DSME to support delay critical applications. When packets move from an originating device to a destination (upward direction) several compensation parameters are computed. These parameters are conveyed MAC packets. The receiving node uses these parameters to compute a compensation factor and conveys that to originating device (to coordinator) (downward direction). Intermediate nodes use compensation factor to do dynamic management of resources in DSME networks. The author has provided an extensive analytical model for this framework. He states that this framework can efficiently support real-time applications.

Silvia Capone et al [43] proposed Enhancements for Low-Power Instrumentation DSME Applications (ELIPDA). This MAC protocol was designed specifically for cluster tree based networks. It was proved through simulations that this proposed MAC protocol reduces the power consumption drastically at the end nodes. MAC protocols like these can be an efficient candidate for destination-oriented, ultra-low-power battery powered wireless sensor networks.

Giuliana et al [44] in their work developed simulative assessments of DSME and TSCH MAC behaviors. She proved that DSME performs better than TSCH in terms of end to end latency when the number of nodes are more than 30. The group ACK feature of DSME helps nodes allocated to DSME GTSs to be acknowledged faster thus reducing end to end latency.

4.2 LLDN

Gaetano et al [45] aimed at improving the scalability of the LLDN by allowing a high number of network nodes while maintaining low cycle times. In this work, they have proposed a Multichannel-LLDN (MC-LLDN) under which nodes communicate on different channels in parallel. There are two levels in this model. They are Higher Level Network (HLN) and a lower level called sub-networks which can support multiple networks. There is a network sub-coordinator that coordinates sub-network and as an end node for the HLN. The author believes this approach achieves lower cycle times, larger radio coverage and higher throughput than the legacy LLDN. Assessments of cycle time, end-to-end latency and throughput were carried out in this work using OMNeT++.

One of the limitations of the LLDN mode is that the uplink slots are reserved whereas the downlink slots remain to be bidirectional. Hence, there is no explicit concept of reserved downlink. This results in lack of determinism in case of infrequent downlinks. Luca et al [46] proposed a reserved downlink timeslots to overcome this limitation. An analytical comparison has been carried out to prove the efficiency over traditional LLDN.

Another multi-hop approach has been proposed by Yarob et al [47]. Mobility-Aware LLDN (MA-LLDN) scheme was developed to overcome the node-mobility problem using the multi-hop approach. The author claims that his approach minimizes both latency and energy consumption while maintaining the LLDN standard protocol. The impact of mobility on LLDN networks was presented in this paper using markov chain methodology. Usage of multi-hop technique reduces the need for additional coordinators in the

system. This will increase the overall power efficiency of the device.

Celia Ouanteur et al [48] have evaluated the performance of the IEEE 802.15.4e LLDN mode by using a three dimensional Markov chain model. They have derived theoretical expressions for reliability, energy consumption, throughput, delay and jitter in LLDN mode and compared with 802.15.4 slotted CSMA/CA to showcase its superiority. Additionally they claim that the reliability of LLDN gives better results than CSMA/CA whatever the data packet length. They also have used Monte Carlo simulations to validate the accuracy of their theoretical analysis.

Berger et al [49] have found that efficiency of LLDN in terms of power efficiency can be increased by combining the use of a relay node and combinatorial testing. Relay nodes can increase the power efficiency by retransmitting the data packet if a negative acknowledgment is indicated in the GACK, thus avoiding packet-transmission failure in the system. Combinatorial testing (CT) stores different erroneous copies of the same source packet and attempts to recover the original data of the source packet by CRC tests on variations of the received packets. A real time implementation was made using MSP430 microcontroller on an MSP430-EXP430F5438 Experimenter Board 2 and a CC2520 transceiver from Texas Instruments on the daughter board CC2520EMK.

Variations in the superframes have been studied for LLDN by Mashood Anwar et al [50]. In his work he provided an insight about relationship of superframe size, base timeslot size and data payload with or without security implementation. In his work he configured the uplink slots for reconfiguration in order to improve the network performance.

4.3 TSCH

Peng du et al in their paper [51] introduced an enhanced version of TSCH called A-TSCH (Adaptive TSCH). He used blacklisting algorithm in order to improve the performance of the existing TSCH mode in 802.15.4e. In this method, the algorithm blacklists channels based on their link quality. In A-TSCH, the transmitting nodes have a knowledge of the neighbors blacklisted channels. Senders and receivers use same hopping sequences for communicating, and the nodes insert this blacklist information in their broadcast. Same process is carried out to maintain the timing information also. A-TSCH was coded on top of Berkley OpenWSN stack and was implemented in Guidance and Inertial Navigation Assistant nodes (GINA). Successful transmission count was calculated in this experiment and it was found that it reduced 5.6% when compared to the normal TSCH operation.

Maria Rita et al in their paper [52] discussed an amalgamation of a power-efficient IEEE 802.15.4-2006 PHY layer, a power saving and reliable IEEE 802.15.4e MAC layer, a IETF 6LoWPAN adaptation layer enabling universal Internet connectivity, an IETF ROLL routing protocol, and an IETF CoAP. The author analyzed the TSCH mode of IEEE 802.15.4e by providing the working model of the MAC behavior and comparing its efficiency to traditional protocols.

Domenico De Guglielmo [53] in his paper provides an analytical model of the TSCH CSMA-CA algorithm to

predict the performance when shared links are utilized in a TSCH network. Delivery probability, packet latency, and energy consumption of nodes are some of the metrics the model helps in evaluating. With simulations using Cooja simulator [54], he claims that the performance of the CSMA/CA depends greatly on the capture effect [55] in the WSN.

Giuliana et al [44] carried a simulation-based performance analysis on DSME and TSCH MAC behaviors. They state that DSME performs better than TSCH in terms of end to end latency when the number of nodes is higher than thirty. In addition, they infer that TSCH has a more flexible slotframe structure than DSME. In TSCH, a single timeslot can be inserted or removed from the slotframe, but every timeslot has to accommodate an acknowledgment. They also stated that the unavailability of GACK in TSCH proves to be a disadvantage in case of larger networks.

Chao Fang et al proposed a new algorithm [56] that generates a frequency hopping sequence in presence of interference without regeneration overhead while maintaining the optimal property. Chao fang contradicts the algorithm of Peng Du. He states that although blacklisting decreases power consumption it changes the channel number and the original Frequency Hopping Scheme (FHS) cannot be used. He provides a thorough analytical model which is supported with simulations using Cooja.

Domenico et al in their paper [57] consider a random based advertisement algorithm for TSCH and evaluate its power efficiency through simulation. The radio has to be always on for the node to join the network. This contributes to power dissipation, the joining time was analyzed in ns2. The author remarks that the standard does not have any method in issuing an Enhanced Beacon. He concludes that joining time is mainly influenced by the number of channel offsets used for advertising Enhanced Beacons.

Several recent studies [58] indicate TSCH to be very competitive industrial IoT MAC protocol. Thomas Watteyne et al presented a model [59] to estimate the latency, power consumption and throughput of a TSCH network. They applied this model to SmartMesh IP, a commercial TSCH product which claims that TSCH has a broad flexibility for industrial scenarios.

Nicola et al [60] gives the details about the implementation of a decentralized Traffic Aware Scheduling Algorithm (TASA) for the OpenWSN stack [61]. Having IEEE802.15.4e TSCH as the MAC layer, OpenWSN implements IoT related standards such as 6LoWPAN, RPL, and CoAP. In this work researchers provide a delta scheduling technique and calculate the performance in terms of duty cycle, delay, link and end-to-end packet loss ratio

Another work on the integration of the RPL topology with TSCH has been done by Ren-Hung Hwang et al [62]. Their method is *DIS-TSCH* which allows every node in the network to independently calculate a time-slot offset and a channel offset within the window of a slotframe for conflict-free transmission. They also provide traffic differentiation by providing scheduling priority to the nodes. Their proposal helps in minimizing the end-to-end packet transfer delay of the IEEE 802.15.4e, while yielding a small network duty cycle.

Jian Wei [63] compares TSCH with Coordinated Sample Listening (CSL). In CSL the transmitter sends wakeup frames to the receiver. The receiver wakes periodically to get the timing information and acknowledges the transmission. TSCH was compared with CSL using Cooja for Contiki OS. Topologies such as star and point-to-point were put to test, it was proved that TSCH outperforms CSL in terms of power efficiency but it trades off with higher delay.

In Table 1, we compare all MAC behaviors of IEEE 802.15.4e and the variants discussed above in the literature survey. We also provide a brief overview of the models (simulations/ analytical/ hardware) available for these protocols and their target applications.

5 PERFORMANCE ANALYSIS

In this section, we provide the performance analysis of all the time critical MAC behaviors using network calculus. The main motivation for this analysis is to visualize the functionalities and showcase its advantage in regards to its predecessor standard.

For this performance analysis we use Network Calculus [64], which is a mathematical formalism used to evaluate the deterministic performance of queuing systems and derive upper bounds on quality-of-service performance metrics, including delay and buffering requirements [65]. It has been used for worst-case dimensioning and delay bound evaluation of WSNs and IEEE 802.15.4 [66], [67], [68], [69], [70], [71], [72]. In particular, Schmitt et al. [66], [67], [68], [69] derived the Sensor Network Calculus framework to analyze worst-case deterministic performance of WSNs. In this deterministic model, a reliable communication between the sensor nodes is assumed. The limitation of this worst-case delay analysis model is that it does not take into account probabilistic communication losses. However, they can be modeled as additional latencies that affect the system performance. The deterministic evaluation allows to derive upper bounds on the delay and buffering requirements, which are useful for the planning and dimensioning of the network [72].

In what follows, we present the Network Calculus model.

Network Calculus considers that traffic flows characterized by a cumulative arrival function denoted as $R(t)$ are bounded by an *arrival curve* $\alpha(t) = b + rt$ where b , r , t are the burst size, data rate and time interval, respectively. The service curve represents the maximum traffic flow that can be generated at any time. On the other hand, the service is characterized by the *minimum service curve* $\beta(t) = R(t - T)^+$ that is guaranteed to $R(t)$, where T is the maximum latency of the service, and t is the time. The specification of the upper bound of the arrival curve and the lower bound of the service allows to determine the maximum delay and also maximum buffering requirement. As shown in Figure 20, the maximum network delay is given by the horizontal distance between the arrival curve and the service curve. Equation 5 presents the expression of the maximum delay as a function of the burst size b , the data rate r and the maximum latency T . This enables the network designer to predict in advance the network properties such as throughput, buffer size or end-to-end delay [72].

$$D_{max} = \frac{b}{r} + T \quad (5)$$

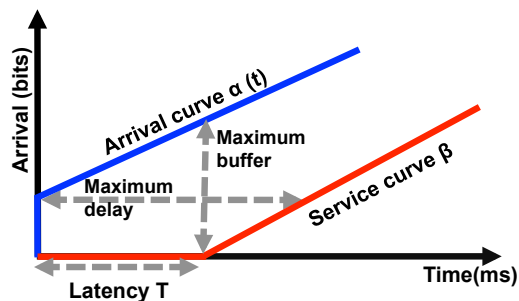

Fig. 20. Arrival curve, service curve, delay bound

A detailed Network Calculus model of DSME, TSCH and LLDN is presented in [73]. In the next subsections, we analyze the worst-case performance of these three real-time MAC behaviors of the IEEE 802.15.4e and compare against the legacy IEEE 802.15.4 standard to understand their advantages and limitations.

5.1 DSME

The purpose of this section is to analyze the performance of DSME in terms of delay and throughput and compare it against the IEEE 802.15.4. The objective is to understand the benefits of the proposed multi-superframe and multi-channel access.

As explained in Section 3.2, the multi-superframe of DSME can group several superframes together within a specific beacon interval. DSME adds multichannel access, CAP reduction and Group Acknowledgment (GACK) as compared to IEEE 802.15.4-2011 superframe. The throughput of the GTS of DSME is the same as that of IEEE 802.15.4 for a single transmission with the same superframe duration. However, a comparison can be made for the overall network throughput, which is the maximum traffic transmitted simultaneously over the network, between a superframe of IEEE 802.15.4 and a multi superframe as in IEEE 802.15.4e.

5.1.1 Throughput Analysis

Assumptions: In this analysis, we consider a DSME multi-superframe that contains three superframes, and we compare its performance against that of the legacy IEEE 802.15.4 single superframe of equal duration. The DSME multi-superframe (bottom) and IEEE 802.15.4 superframe used in this scenario are depicted in Figure 21. We consider various superframe orders ranging from $[0, 10]$ and different arrival rates (5, 50, 100 Kbps) at a constant burst size of 2 Kbits.

Results: Figure 22 plots the throughput for the various arrival rates as a function of the SO , for the scenarios described above. It can be noticed that both standards have a similar behavior. This is because when the value of the superframe order increases, the length of the timeslot and the beacon interval increase proportionately, thus, obviously affecting the overall throughput. From Figure 22, we observe that the value of the throughput of IEEE 802.15.4e

TABLE 1
Comparison of the MAC behaviors and its variants

MAC behaviors and variants	Scalability	Reliability	Power Efficiency	Multichannel Access	Group Acknowledgement	Available tools Simulations : S Analytical : A Hardware : H	Applications Intended
RFID	-	medium	high	no	no	S, A, H	Tracking and identification
AMCA	yes	medium	medium	yes	no	NA	non time sensitive applications with high scalability requirements
DSME	yes	high	Depends on the number of nodes	yes	yes	S, A	Time critical applications with high scalability non critical applications (CAP)
TSCH	yes	Very high	Higher than DSME	yes	no	S, A	Time critical applications with energy efficiency requirements
A-TSCH	yes	Higher than TSCH	Almost equal to TSCH	Uses blacklisting	no	S, H (GINA)	similar to TSCH -with high reliability requirements
LLDN	no	Very high	higher than DSME	no - Uses TDMA	yes	S	Industrial Automation - fixed number of nodes
MC-LLDN	yes	Very high	Lesser to LLDN	yes	yes	S	Industrial Automation - variable number of nodes
ELIPDA	yes	high	Lesser than DSME	yes	yes	S	Similar to DSME
MA- LLDN	yes	Very high	Higher than LLDN	Uses multi hop	yes	A-Markov chain	similar to LLDN

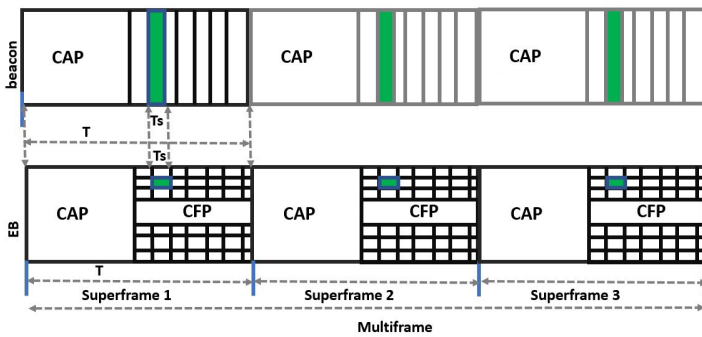

Fig. 21. DSME multi-superframe (bottom) vs. IEEE 802.15.4 superframe

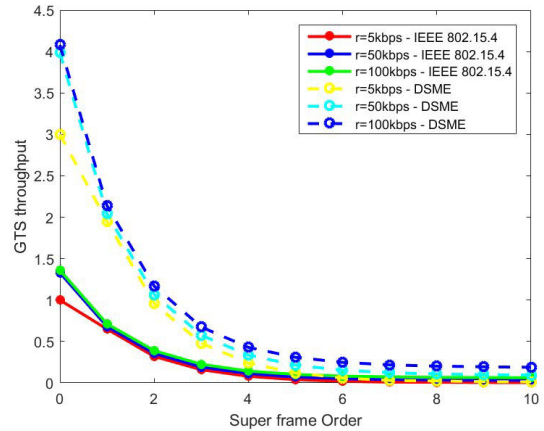

Fig. 22. DSME throughput as a function of the arrival rate

DSME is 33% higher than that of the legacy IEEE 802.15.4 and this value is dependent on the number of superframes of the multi-superframe.

The increased throughput in DSME is a result of the modified superframe that has the ability to support multi-channel access. This property helps us understand why DSME is more suitable for applications with high scalability and throughput requirements. This observation confirms the results published in [37] and [43] in which the authors compared the throughput of a multi-channel DSME network against the standard CSMA/CA and IEEE 802.15.4-2011.

5.1.2 Throughput Analysis - CAP Reduction

Assumptions: In this section, we analyze the impact of CAP reduction feature of DSME on the throughput. For the analysis of CAP reduction, we consider the same scenarios and parameters as in the previous experiment. The configuration of the DSME multi-superframes used in this study are depicted in the Figure 23. Two multi-superframes that contain three superframes of equal durations. We compare the through and delay of DSME with and without CAP reduction. It should be noted that the timeslots are of equal size and the allocation of a GTS is carried out in a round

robin fashion. The CAP in a superframe has a fixed size of 440 symbols in accordance to the standard. The throughput is calculated for varying SO from (0-9).

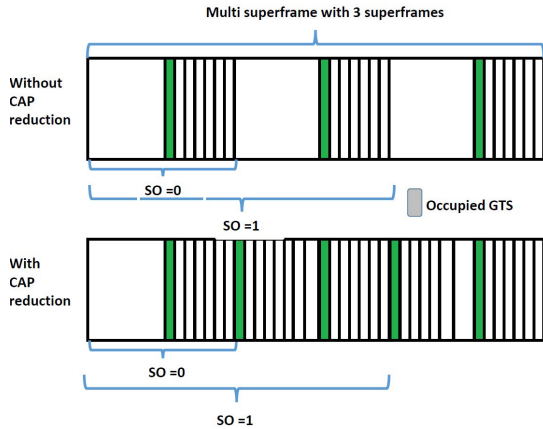

Fig. 23. CAP reduction - scenario

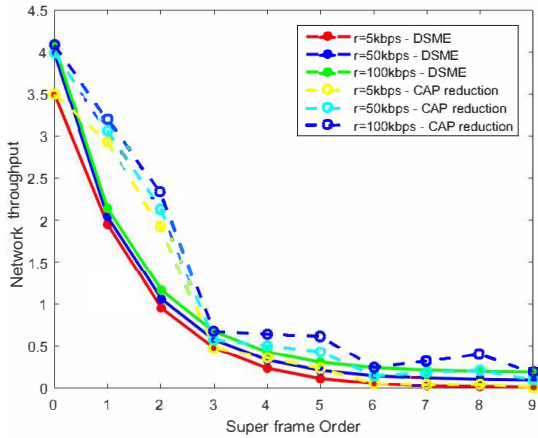

Fig. 24. DSME throughput analysis with and without CAP reduction

Results: We observe that the network throughput increases with 7% with CAP reduction as the available CFP bandwidth increases. CAP reduction further increases the overall scalability of the network with the provision of additional DSME GTs. A similar analysis for CAP reduction was done in [37], in which the authors compare the net-throughput of 56 GTs timeslots (without CAP reduction) to 112 GTs timeslots with CAP reduction. Their results show that there is a similar increase in throughput.

5.1.3 Delay Analysis

Assumptions: We also compared the delay of the legacy IEEE 802.15.4 against a multichannel enabled DSME network. In case of DSME, we used multiple (2, 3, 4, 6) channels providing an equal bandwidth of 250 Kbits/sec for transmission for varying Beacon Intervals (BI). The delay bound depends on the arrival rate and the burst size as shown in Equation 4. We evaluate the delay bound for a single flow in the network as a function of the burst size.

Results: Figure 25 shows the delay results of the DSME as compared to the legacy 802.15.4. When comparing a DSME network against a 802.15.4 network, we observe

that the delay reduces with DSME to 50% when using two channels, and reduces to 25% for five channels. In general, the delay is proportional to the number of channels. In fact, DSME ensures a higher number of data transmissions (flows) within a single time slot because of its multichannel capabilities. Researchers in [44] had already provided similar results stating that dense DSME networks with more than 50 nodes provided less delay than their counterparts like TSCH, in our simulation we showcase the effect of multichannel on the overall delay of the network.

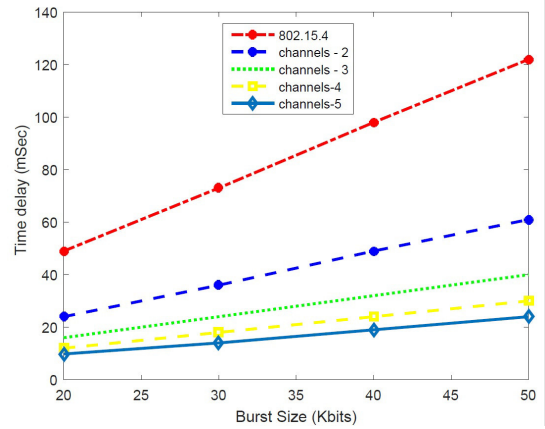

Fig. 25. DSME delay analysis as a function of the burst size

5.2 LLDN

The purpose of this section is to analyze (1) the impact of the superframe order on the network throughput and (2) the impact of the number of timeslots on the delay in case of an LLDN-enabled network.

5.2.1 Throughput Analysis

Assumptions: The analysis was done for a LLDN-enabled star topology network. The throughput analysis was conducted for a constant burst size of 5 Kbits and the arrival rate was varied from 60 to 250 Kbps for several SO in the range [1-10]. The traffic is considered over the uplink timeslots of an LLDN superframe. The results are the same in case of downlink timeslots considering their symmetry. Even if we consider the bidirectional timeslots are handling the traffic, we will get similar results.

Results: The results of LLDN are similar to those of DSME. There is nearly a 50% decrease in throughput with the increase in the superframe order because of the wasted bandwidth. As LLDN lacks multichannel extension, LLDN provides 20% lesser throughput than DSME. The corresponding results are plotted in Figure 26. Unlike DSME, LLDN lacks multichannel access and multi superframe capabilities. The throughput of an LLDN enabled network is dependent on the traffic in the uplink timeslots, downlink time slots and the retransmission time slots. Still due to its strict timeliness properties, collision is efficiently avoided.

5.2.2 Delay Analysis

Assumptions: We study the delay for a star topology with a varying number of nodes (1-15) over 15 equally sized

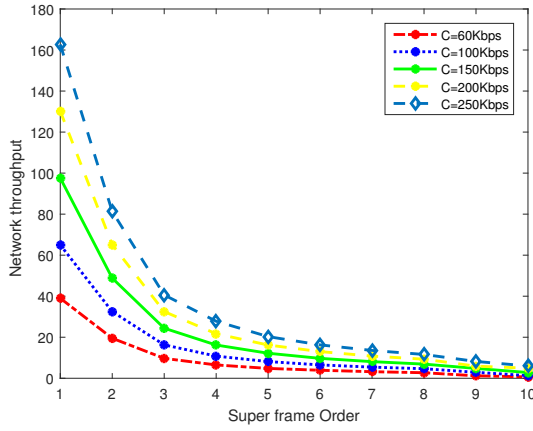

Fig. 26. LLDN throughput as a function of the arrival rate

timeslots. Delay is calculated in seconds over 15 uplink timeslots that repeat in a round robin fashion, and for a different number of timeslots [1-10].

Results: The delay is plotted in Figure 27 and is found to be proportional to both the number of nodes as well as the number of time slots available for transmission. When there are more timeslots available for allocation to nodes, there is a linear decrease in the delay. It can be noticed that delay **decreases** by 80%, when the number of nodes increases from 1 to 10.

LLDN ensures a very stable delay as it relies solely on the size of the uplink and downlink timeslots. The fixed retransmission timeslots also contribute to the delay. Though they are not always utilized, they help in providing a more fault tolerant network [48].

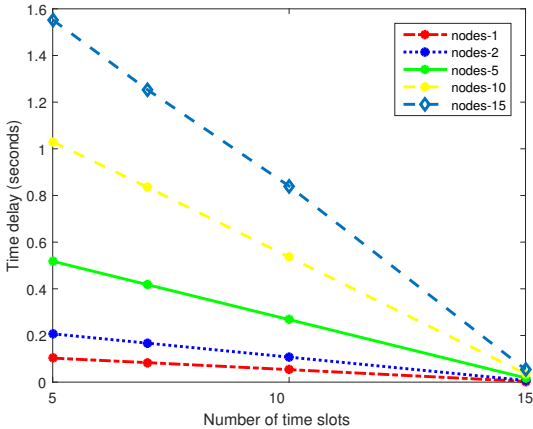

Fig. 27. LLDN delay analysis

5.3 TSCH

The purpose of this section is to analyze the impact of the duty cycle on the throughput of a TSCH network. In addition, we study the impact of the fixed timeslots on the delay.

5.3.1 Throughput Analysis

Assumptions: TSCH is different from DSME and LLDN due to its slotframe structure that relies on either dedicated timeslots or CSMA/CA in case of shared timeslots.

For throughput analysis we consider the dedicated timeslots. The throughput of the system varies with respect T_{cycle} which is a collective repetition of timeslots. In our analysis one T_{cycle} comprises 5 timeslots. For the throughput analysis, we varied the T_{cycle} for different arrival rates. The analysis is carried out for a network supporting multiple number of nodes in the range [1-10]. The timeslot of TSCH has a fixed value of 10 ms in accordance to the standard. The simulations were carried out considering five frequency channels with equal bandwidths.

Results: From Figure 28, we observe that the time cycles show a similar behavior to that of the superframe orders in DSME and LLDN (i.e., higher arrival rates allow achieving higher throughputs). Similar to that of DSME, multi-channel access plays a crucial role in increasing the overall throughput of TSCH, but it lacks techniques like CAP reduction and group acknowledgment that can help achieving better scalability and higher throughput.

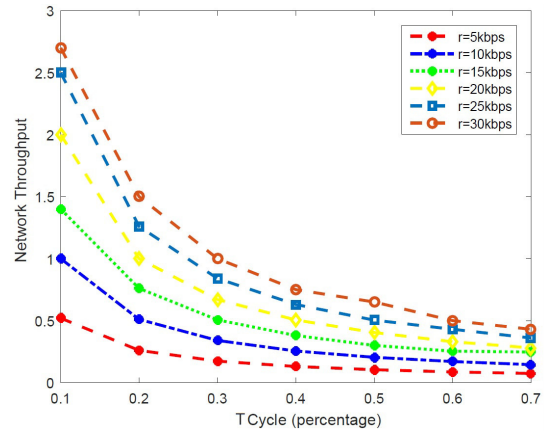

Fig. 28. TSCH throughput as a function of the T cycle

5.3.2 Delay Analysis

Assumptions: We study the network delay for several nodes against different values of T_{cycle} (0-35). The timeslot of TSCH has a fixed value of 10 ms in accordance to the standard. When the T_{cycle} value is within 10 ms, the network has nil delay. Beyond 10 ms, a new timeslot will be used to transmit the data, thereby increasing the delay proportionately.

Results: The delay of TSCH is illustrated in Figure 29. It should be noted that the delay is dependent on the number of nodes that occupy the network. The delay increases by 7% with the increase of 10 nodes in the network.

The fixed timeslot length of TSCH helps in achieving a constant delay for 10 ms but with the increase in T_{cycle} , the delay increases proportionally. Dedicated timeslots of TSCH are very similar to the uplink slots of LLDN and they provide similar delay properties. A similar result can be learned from the comparative studies made on DSME and TSCH by the authors in [44], in which they observe that 80 % of messages in DSME experience a 10% lower delay when compared to TSCH.

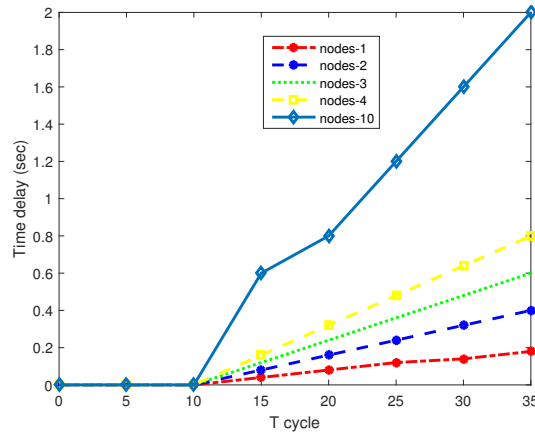

Fig. 29. TSCH delay analysis - delay over Tcycle

6 IMPLEMENTATION AND TOOLS

There is still much to be done in terms of tool development and protocol implementation for IEEE 802.15.4e based networks. TSCH has got the attention of many researchers due to its industry oriented timeslot based communication and multi-channel capabilities. Hence, there are some protocol stack implementations based on TSCH and simulation tools available.

6TiSCH [74], [75] is a working group formed by IETF (Internet Engineering Task Force), which is responsible for standardizing efforts such as 6LoWPAN and ROLL [76]. 6TiSCH working group aims at achieving a full adaptation of IPv6 over TSCH. The routing protocol for low power and lossy networks (RPL) is also converged with TSCH to improve its functionalities. The complete architecture and terminology of 6TiSCH is expected to be published by the end of December 2018 [77]. 6TiSCH has been evaluated over the TelosB mote hardware platform running OpenWSN [78]. Configurations such as single channel, channel hopping and CSMA/CA are available for experimental evaluation.

To support TSCH in highly dynamic networks, the EIT (European Institute of innovation and technology) proposed Orchestra [79]. This mechanism introduces distributed scheduling capabilities for the 6TiSCH network. In orchestra, nodes automatically compute their own local schedules and maintain several schedules for different traffic scenarios. Orchestra, in order to maintain schedules, relies on the existing network stack and not any distributed or central scheduler. TSCH and orchestra were implemented in ContikiOS [80] to validate the mechanism. Experiments were run on two hardware platforms an Indriya setup [81] with 98 TelosB [82] nodes and the JN-IoT test bed with 26 JN5168 nodes. The Cooja network simulator was used to emulate the TelosB nodes in the setup. Many features of TSCH such as ASN, basic scheduling, timeslot template, CSMA/CA mechanism and security have been implemented using the protocol stack in [61]. An NS3 based simulation model that provides energy and the multi-path fading models for a TSCH enabled network is also available.

One popular tool is the open source implementation of the IEEE 802.15.4e standard called *OpenWSN* [83]. OpenWSN aims at providing an ultra-low power, highly reliable mesh network. This is the first open source imple-

mentation of a protocol stack based on the TSCH MAC behavior. The authors have ported OpenWSN to support various platforms such as GINA [84] and OpenMote-STM32. OpenMoteSTM features an STMicroelectronic STM32F103RB 32-bit micro-controller in an Atmel based AT86RF231 IEEE802.15.4-compliant radio. GINA works over the same radio but the transceiver uses a Texas Instruments MSP430F2618 16-bit micro-controller.

Apart from TSCH, to the best of our knowledge, the other MAC behaviors were never fully implemented. Nevertheless, there are some simulation models available.

A Matlab tool has been developed for all the three time critical MAC behaviors to calculate their respective throughput and delay. This GUI model is available as one of the open-ZB simulation models [85]. For DSME several parameters such as the burst size, arrival rate, superframe order, beacon order, beacon interval, data rate can be used to compute the throughput and the delay. For LLDN, the number of nodes in the network, the superframe order, burst size and the arrival rate can be used to calculate the respective throughput and the delay. TSCH is supported considering the number of nodes, data size and the burst size and the cycles for which every timeslot repeats (T_{cycle}) to calculate its respective throughput and delay. This tool will help the network engineer to understand the features and limits of the IEEE 802.15.4e by enabling the computation of its worst-case bounds thus supporting network dimensioning and planning activities.

7 CHALLENGES AND FUTURE RESEARCH

Several technologies such as 6LoWPAN have combined protocols such as IEEE 802.15.4 and IPV6 to make it suitable for a variety of applications with seamless connectivity to the internet. The IEEE 802.15.4e is a haven of several MAC behaviors and can fit an even wider range of applications. Still, some researchers have worked on improving these with unique characteristics to fit specific scenarios, for example, MC-LLDN incorporates the multichannel access enhancement of DSME to the LLDN MAC behavior. This has proven to be more effective than the original standard for the given scenario. Thus, there is this quite an interesting possibility of combining technologies in order to further improve the protocol for very specific applications with demanding QoS requirements.

A challenge that is transversal to the different IEEE 802.15.4e MACs concerns safety and security. While the academic community has been mainly focused on improving the standard by adding additional enhancements to the existing MAC protocol e.g. EFastA, ELIPDA, Adaptive TSCH, MA-LLDN, there are still several concerns on the safety and security aspects of communication. For instance, TSCH could be easily exploited via a quite energy efficient jamming attack, considering the channel hopping sequence is easily predictable as is the start-time of the transmission slots. The same applies to DMSE or LLDN where nodes are always assumed trustworthy. These issues must be addressed if IEEE 802.15.4e is ever to be used in safety-critical applications.

IEEE 802.15.4e provides ample possibilities for being implemented in a wide range of applications, but there is

a clear lack of protocol implementations and supporting hardware available. Real platforms are very much needed to support a standard, by pushing forward the technology and help promoting its faster adoption, specially by easing their application into real life scenarios. The IEEE 802.15.4 has become a phenomenon in wireless sensor networks because of its availability on Commercial Off The Shelf (COTS) technology. This enabled it to become a base standard for several protocols such as ZigBee, 6LoWPAN and wirelessHART. IEEE 802.15.4e has all the attributes of becoming a de-facto standard, but a significant effort has to be put forward in developing hardware implementations based on this standard, specially concerning DSME and LLDN MAC behaviors.

On the other hand, simulations are also very important to explore and understand the behavior of the technology, its advantages, drawbacks and any potential pitfalls. Several simulation studies have been performed over the time critical MAC behaviors of 802.15.4e. For instance, several QoS properties such as throughput, latency, power efficiency have been simulated using existing tools such as the Cooja network simulator [86], [87], NS2 [88] and Omnet++ [89].

7.1 LLDN

The LLDN MAC behavior is clearly targeted at star-based applications where a considerable number of nodes communicates with a central node, as in the case of several automation applications in the industrial domain. It mostly relies on a TDMA approach to support higher reliability and determinism regarding communication latency. Contrary to other MAC behaviors, LLDN does not support multichannel access which might become problematic when facing degraded channel conditions.

A different issue concerns LLDN lack of flexibility in handling sporadic traffic, a common problem in TDMA-based networks. In addition, a thorough network planning must be done in advance concerning the number of nodes and expected packet sizes, which is mandatory to successfully setup the Discovery and Configuration network states. This is specially important since it is unclear how an LLDN network can come back from Online state to reconfigure the node scheduling. The impact of the superframe is well explored in our results and in [51], however, possibilities of dynamic allocation of timeslots and the effect of retransmission timeslots on them can be explored.

7.2 DSME

DSME is probably the most flexible MAC behavior from all the IEEE 802.15.4e proposals. Its multisuperframe structure allows for the transmission of both periodic as well sporadic traffic, while still supporting a fast reconfiguration of the DSME-GTS schedule. This constitutes its main advantage. Despite all of these advantages, it failed to receive enough attention as TSCH for instance. Noticeably, there are no trustworthy protocol stack implementations available, nor simulation tools that completely implement its functionalities. Understandingly, this creates a major gap in the maturity of the solutions, and it is clear that routing functionalities (mesh networking) are not tested nor clearly addressed both in the standard or the literature. It is unclear, for instance how the scheduling of DSME-GTSs would

perform in a mesh setup, or even if beacon scheduling could work at all, considering its limitations. Hence, how to connect DSME with RPL for instance, or how to support 6LoWPAN to build a more complete protocol stack, is still completely open for research. CAP reduction for instance, provides a significant quality improvement as discussed in Section 5.1.2. however, ideas like triggering CAP reduction autonomously in a dynamic fashion can be explored.

Other issues such as how to carryout an efficient DSME-GTS allocation could also deserve some more attention, specially if one intends to extend GTS support to a mesh network. Also, considering the flexible properties of the MAC, further studies on adaptability and robustness could be carried out, aiming at improving the performance concerning different QoS properties, such as timeliness or energy-efficiency.

7.3 TSCH

From all the time-critical IEEE 802.15.4e MAC behaviors, TSCH is the one that received most of the attention from the research community. This is mostly due to the joining of long desired features on IEEE 802.15.4 such as a time-slotted MAC, multichannel and channel hopping functionalities. Unlike DSME, TSCH does not provide channel adaptation techniques. Possibilities of a dynamic channel adaptation scheme for TSCH can be explored. Regarding latency, as mentioned in Section 5.3.2, 10 ms timeslots constitute a major advantage, being able to achieve much lower latencies than the legacy IEEE 802.15.4 either using CSMA or GTS. Nevertheless, there are still several issues that deserve further attention. For instance, probably from its close relationship with 6TiSCH, TSCH is usually considered in a network setup that provides a central sink node (usually the PAN Coordinator) to which all information flows. This kind of converge-cast architecture might not be the most adequate to address the challenges of the future IoT and Cyber Physical Systems, in which a close interaction and cooperation between the several sensor and actuator components is expected. Thus, the protocol will have to encompass lighter and more energy-efficient scheduling and routing algorithms if this is to be achieved.

8 CONCLUSION

As a significant contributing part of IoT, emerging Cyber Physical Systems impose a set of much more stringent requirements on the communication layers than the previous generation of embedded systems. To cope with these, traditional wireless low-power standards such as the IEEE 802.15.4 have been subjected to extensive work in an effort to encompass improved timeliness, robustness, and scalability.

Recently, the IEEE 802.15.4e amendment, completely reformulated the legacy IEEE 802.15.4 protocol, by proposing a set of alternative MAC behaviors to address these concerns. This was achieved by implementing mechanisms to support multi-channel communications, frequency hopping, and time-division channel access.

Although this represents a significant step in the right direction, it is important to gain enough sensibility to understand both the adequacy of the standard to an application

and the performance gain regarding the previous protocol. This can only be achieved by carrying out a thorough study of the standard and by modeling the performance limits of the IEEE 802.15.4e MAC behaviors.

More than just an up-to-date literature survey of the research work on the protocol, in this work, we address those two tasks. We present a performance analysis and thorough discussion of the main features and enhancements of this standard by relying on a Network Calculus model. It is our understanding that the technology is still quite young and immature, thus there is still enough room for improving the protocol, specially in what concerns security. These open issues and challenges are also discussed in this work.

Finally, the lack of complete protocol stack implementations of this standard must be addressed sooner rather than later, before it becomes a severe hindrance and to push forward the IEEE 802.15.4e as a federated communication technology to support the future IoT.

ACKNOWLEDGEMENTS

This work was partially supported by National Funds through FCT/MEC (Portuguese Foundation for Science and Technology) and co-financed by ERDF (European Regional Development Fund) under the PT2020 Partnership, within the CISTER Research Unit (CEC/04234); also by FCT/MEC and the EU ECSEL JU under the H2020 Framework Programme, within project ECSEL/0002/2015, JU grant nr. 692529-2 (SAFECOP). This work is also supported by the Research and Translation Center (RTC) at Prince Sultan University via Grant Number GP-CCIS-2013-11-10.

REFERENCES

- [1] G. Werner-Allen, J. Johnson, M. Ruiz, J. Lees, and M. Welsh, "Monitoring volcanic eruptions with a wireless sensor network," in *Wireless Sensor Networks, 2005. Proceedings of the Second European Workshop on*, pp. 108–120, IEEE, 2005.
- [2] T. Harms, S. Sedigh, and F. Bastianini, "Structural health monitoring of bridges using wireless sensor networks," *Instrumentation & Measurement Magazine, IEEE*, vol. 13, no. 6, pp. 14–18, 2010.
- [3] R. Severino, R. F. Gomes, M. Alves, E. Tovar, R. Aguilár, P. Lourenço, and P. G. de Sousa, "A wireless sensor network platform for structural health monitoring: enabling accurate and synchronized measurements through cots+ custom-based design," in *5th IFAC International Conference on Management and Control of Production and Logistics*, 2010.
- [4] J. H. Kurunathan, "Study and overview on wban under ieee 802.15. 6," *U. Porto Journal of Engineering*, vol. 1, no. 1, pp. 11–21, 2015.
- [5] J. Lee, B. Bagheri, and H.-A. Kao, "A cyber-physical systems architecture for industry 4.0-based manufacturing systems," *Manufacturing Letters*, vol. 3, pp. 18–23, 2015.
- [6] K. Wang, Y. Wang, Y. Sun, S. Guo, and J. Wu, "Green industrial internet of things architecture: An energy-efficient perspective," *IEEE Communications Magazine*, vol. 54, no. 12, pp. 48–54, 2016.
- [7] J. Wu, J. Thompson, H. Zhang, and D. C. Kilper, "Green communications and computing networks [series editorial]," *IEEE Communications Magazine*, vol. 53, no. 11, pp. 148–149, 2015.
- [8] C. Estevez and J. Wu, "Recent advances in green internet of things," in *Communications (LATINCOM), 2015 7th IEEE Latin-American Conference on*, pp. 1–5, IEEE, 2015.
- [9] J. Wu, S. Guo, J. Li, and D. Zeng, "Big data meet green challenges: Greening big data," *IEEE Systems Journal*, vol. 10, no. 3, pp. 873–887, 2016.
- [10] R. Severino, S. Ullah, and E. Tovar, "A cross-layer qos management framework for zigbee cluster-tree networks," *Telecommun. Syst.*, vol. 63, pp. 381–397, Nov. 2016.
- [11] R. Severino, N. Pereira, and E. Tovar, "Dynamic cluster scheduling for cluster-tree wsns," *SpringerPlus*, vol. 3, no. 1, p. 1, 2014.
- [12] "Ieee standard for local and metropolitan area networks—part 15.4: Low-rate wireless personal area networks (lr-wpans) amendment 1: Mac sublayer," *IEEE Std 802.15.4e-2012 (Amendment to IEEE Std 802.15.4-2011)*, pp. 1–225, April 2012.
- [13] "Ieee standard for information technology—local and metropolitan area networks—specific requirements— part 15.4: Wireless medium access control (mac) and physical layer (phy) specifications for low rate wireless personal area networks (wpans)," *IEEE Std 802.15.4-2006 (Revision of IEEE Std 802.15.4-2003)*, pp. 1–320, Sept 2006.
- [14] "Ieee standard for low-rate wireless networks," *IEEE Std 802.15.4-2015 (Revision of IEEE Std 802.15.4-2011)*, pp. 1–709, April 2016.
- [15] C. Lu, B. M. Blum, T. F. Abdelzaher, J. A. Stankovic, and T. He, "Rap: A real-time communication architecture for large-scale wireless sensor networks," in *Real-Time and Embedded Technology and Applications Symposium, 2002. Proceedings. Eighth IEEE*, pp. 55–66, IEEE, 2002.
- [16] W. Ye, J. Heidemann, and D. Estrin, "An energy-efficient mac protocol for wireless sensor networks," in *INFOCOM 2002. Twenty-First Annual Joint Conference of the IEEE Computer and Communications Societies. Proceedings. IEEE*, vol. 3, pp. 1567–1576, IEEE, 2002.
- [17] T. Van Dam and K. Langendoen, "An adaptive energy-efficient mac protocol for wireless sensor networks," in *Proceedings of the 1st international conference on Embedded networked sensor systems*, pp. 171–180, ACM, 2003.
- [18] Z. Alliance *et al.*, "Zigbee specification," 2006.
- [19] T. Winter, "Rpl: Ipv6 routing protocol for low-power and lossy networks," 2012.
- [20] "Ieee standard for smart transducer interface for sensors and actuators—transducers to radio frequency identification (rfid) systems communication protocols and transducer electronic data sheet formats," *IEEE Std 1451.7-2010*, pp. 1–99, June 2010.
- [21] D. Williams, "The strategic implications of wal-mart's rfid mandate," *Directions Magazine*, vol. 28, 2004.
- [22] Y. Xiao, X. Shen, B. Sun, and L. Cai, "Security and privacy in rfid and applications in telemedicine," *Communications Magazine, IEEE*, vol. 44, no. 4, pp. 64–72, 2006.
- [23] S. Kim, S. Pakzad, D. Culler, J. Demmel, G. Fenves, S. Glaser, and M. Turon, "Wireless sensor networks for structural health monitoring," in *Proceedings of the 4th international conference on Embedded networked sensor systems*, pp. 427–428, ACM, 2006.
- [24] Y. Li, Y.-Q. Song, R. Schott, Z. Wang, and Y. Sun, "Impact of link unreliability and asymmetry on the quality of connectivity in large-scale sensor networks," *Sensors*, vol. 8, no. 10, pp. 6674–6691, 2008.
- [25] L. Hou and N. W. Bergmann, "System requirements for industrial wireless sensor networks," in *Emerging Technologies and Factory Automation (ETFA), 2010 IEEE Conference on*, pp. 1–8, IEEE, 2010.
- [26] E. Karulf, "Body area networks (ban)," 2008.
- [27] P. Dutta, J. Hui, J. Jeong, S. Kim, C. Sharp, J. Taneja, G. Tolle, K. Whitehouse, and D. Culler, "Trio: enabling sustainable and scalable outdoor wireless sensor network deployments," in *Proceedings of the 5th international conference on Information processing in sensor networks*, pp. 407–415, ACM, 2006.
- [28] J. Suhonen, M. Kohvakka, V. Kaseva, T. D. Hämäläinen, and M. Hännikäinen, *Low-power wireless sensor networks: protocols, services and applications*. Springer Science & Business Media, 2012.
- [29] CISCO, "20 myths of wi-fi interference: Dispel myths to gain high-performing and reliable wireless." <http://www.cisco.com/c/en/us/products/collateral/wireless/spectrum-expert-wi-fi>.
- [30] J. W. Smith, "Radio communication system using synchronous frequency hopping transmissions," July 18 1989. US Patent 4,850,036.
- [31] S. Williams, L. T. Parker, and A. M. Howard, "Terrain reconstruction of glacial surfaces: Robotic surveying techniques," *Robotics & Automation Magazine, IEEE*, vol. 19, no. 4, pp. 59–71, 2012.
- [32] M. M. Hanna, A. Buck, and R. Smith, "Fuzzy petri nets with neural networks to model products quality from a cnc-milling machining centre," *Systems, Man and Cybernetics, Part A: Systems and Humans, IEEE Transactions on*, vol. 26, no. 5, pp. 638–645, 1996.
- [33] S. Petersen, P. Doyle, S. Vatland, C. S. Aasland, T. M. Andersen, and D. Sjong, "Requirements, drivers and analysis of wireless sensor network solutions for the oil & gas industry," in *Emerging Technologies and Factory Automation, 2007. ETFA. IEEE Conference on*, pp. 219–226, IEEE, 2007.

- [34] N. Pereira, S. Tennina, and E. Tovar, "Building a microscope for the data center," in *Wireless Algorithms, Systems, and Applications*, pp. 619–630, Springer, 2012.
- [35] D. De Guglielmo, G. Anastasi, and A. Seghetti, "From ieee 802.15.4 to ieee 802.15.4e: A step towards the internet of things," in *Advances onto the Internet of Things*, pp. 135–152, Springer, 2014.
- [36] D. De Guglielmo, S. Brienza, and G. Anastasi, "Ieee 802.15.4e: A survey," *Computer Communications*, vol. 88, pp. 1–24, 2016.
- [37] W.-C. Jeong and J. Lee, "Performance evaluation of ieee 802.15.4e dsme mac protocol for wireless sensor networks," in *Enabling Technologies for Smartphone and Internet of Things (ETSIoT), 2012 First IEEE Workshop on*, pp. 7–12, IEEE, 2012.
- [38] J. Lee and W.-C. Jeong, "Performance analysis of ieee 802.15.4e dsme mac protocol under wlan interference," in *ICT Convergence (ICTC), 2012 International Conference on*, pp. 741–746, IEEE, 2012.
- [39] P. K. Sahoo, S. R. Pattanaik, and S.-L. Wu, "A reliable data transmission model for ieee 802.15.4e enabled wireless sensor network under wifi interference," *Sensors*, vol. 17, no. 6, p. 1320, 2017.
- [40] X. Liu, X. Li, S. Su, Z. Fan, and G. Wang, "Enhanced fast association for 802.15.4e-2012 dsme mac protocol," in *Proceedings of the 2nd International Conference on Computer Science and Electronics Engineering*, Atlantis Press, 2013.
- [41] T. Paso, J. Haapola, and J. Iinatti, "Feasibility study of ieee 802.15.4e dsme utilizing ir-uw and s-aloha," in *Personal Indoor and Mobile Radio Communications (PIMRC), 2013 IEEE 24th International Symposium on*, pp. 1863–1867, IEEE, 2013.
- [42] M. Taneja, "A framework to support real-time applications over ieee802.15.4 dsme," in *Intelligent Sensors, Sensor Networks and Information Processing (ISSNIP), 2015 IEEE Tenth International Conference on*, pp. 1–6, IEEE, 2015.
- [43] S. Capone, R. Brama, F. Ricciato, G. Boggia, and A. Malvasi, "Modeling and simulation of energy efficient enhancements for ieee 802.15.4e dsme," in *Wireless Telecommunications Symposium (WTS), 2014*, pp. 1–6, IEEE, 2014.
- [44] G. Alderisi, G. Patti, O. Mirabella, and L. L. Bello, "Simulative assessments of the ieee 802.15.4e dsme and tsch in realistic process automation scenarios," in *Industrial Informatics (INDIN), 2015 IEEE 13th International Conference on*, pp. 948–955, IEEE, 2015.
- [45] G. Patti, G. Alderisi, and L. L. Bello, "Introducing multi-level communication in the ieee 802.15.4e protocol: the multichannel-ldn," in *Emerging Technology and Factory Automation (ETFA), 2014 IEEE*, pp. 1–8, IEEE, 2014.
- [46] L. Dariz, M. Ruggeri, and G. Malaguti, "A proposal for enhancement towards bidirectional quasi-deterministic communications using ieee 802.15.4," in *2013 21st Telecommunications Forum Telfor (TELFOR)*, 2013.
- [47] Y. Al-Nidawi, H. Yahya, and A. Kemp, "Tackling mobility in low latency deterministic multihop ieee 802.15.4e sensor network," 2015.
- [48] C. Ouanteur, D. Aissani, L. Bouallouche-Medjkoune, M. Yazid, and H. Castel-Taleb, "Modeling and performance evaluation of the ieee 802.15.4e lldn mechanism designed for industrial applications in wsns," *Wireless Networks*, vol. 23, no. 5, pp. 1343–1358, 2017.
- [49] A. Berger, A. Entinger, A. Potsch, and A. Springer, "Improving ieee 802.15.4e lldn performance by relaying and extension of combinatorial testing," in *Emerging Technology and Factory Automation (ETFA), 2014 IEEE*, pp. 1–4, IEEE, 2014.
- [50] M. Anwar and X. Yuanqing, "Ieee 802.15.4e lldn: Superframe configuration for networked control systems," in *Control Conference (CCC), 2014 33rd Chinese*, pp. 5568–5573, IEEE, 2014.
- [51] P. Du and G. Roussos, "Adaptive time slotted channel hopping for wireless sensor networks," in *Computer Science and Electronic Engineering Conference (CEEC), 2012 4th*, pp. 29–34, IEEE, 2012.
- [52] M. R. Palattella, N. Accettura, M. Dohler, L. A. Grieco, and G. Boggia, "Traffic aware scheduling algorithm for reliable low-power multi-hop ieee 802.15.4e networks," in *Personal Indoor and Mobile Radio Communications (PIMRC), 2012 IEEE 23rd International Symposium on*, pp. 327–332, IEEE, 2012.
- [53] D. De Guglielmo, B. Al Nahas, S. Duquennoy, T. Voigt, and G. Anastasi, "Analysis and experimental evaluation of ieee 802.15.4e tsch csma-ca algorithm," *IEEE Transactions on Vehicular Technology*, vol. 66, no. 2, pp. 1573–1588, 2017.
- [54] J. Eriksson, F. Österlind, N. Finne, N. Tsiftes, A. Dunkels, T. Voigt, R. Sauter, and P. J. Marrón, "Cooja/mspsim: interoperability testing for wireless sensor networks," in *Proceedings of the 2nd International Conference on Simulation Tools and Techniques*, p. 27, ICST (Institute for Computer Sciences, Social-Informatics and Telecommunications Engineering), 2009.
- [55] M. Mohammad, M. Doddavenkatappa, and M. C. Chan, "Improving performance of synchronous transmission-based protocols using capture effect over multichannels," *ACM Transactions on Sensor Networks (TOSN)*, vol. 13, no. 2, p. 10, 2017.
- [56] C.-F. Shih, A. E. Khafa, and J. Zhou, "Practical frequency hopping sequence design for interference avoidance in 802.15.4e tsch networks," in *Communications (ICC), 2015 IEEE International Conference on*, pp. 6494–6499, IEEE, 2015.
- [57] D. De Guglielmo, A. Seghetti, G. Anastasi, and M. Conti, "A performance analysis of the network formation process in ieee 802.15.4e tsch wireless sensor/actuator networks," in *Computers and Communication (ISCC), 2014 IEEE Symposium on*, pp. 1–6, IEEE, 2014.
- [58] K. T. Kim, H. Kim, H. Park, and S.-T. Kim, "An industrial iot mac protocol based on ieee 802.15.4e tsch for a large-scale network," in *Advanced Communication Technology (ICACT), 2017 19th International Conference on*, pp. 721–724, IEEE, 2017.
- [59] T. Watteyne, J. Weiss, L. Doherty, and J. Simon, "Industrial ieee802.15.4e networks: Performance and trade-offs," in *Communications (ICC), 2015 IEEE International Conference on*, pp. 604–609, IEEE, 2015.
- [60] N. Accettura, E. Vogli, M. R. Palattella, L. A. Grieco, G. Boggia, and M. Dohler, "Decentralized traffic aware scheduling in 6tisch networks: Design and experimental evaluation," *Internet of Things Journal, IEEE*, vol. 2, no. 6, pp. 455–470, 2015.
- [61] O. WSN, "Orchestra protocol stack," 2016. <https://github.com/EIT-ICT-RICH>.
- [62] R.-H. Hwang, C.-C. Wang, and W.-B. Wang, "A distributed scheduling algorithm for ieee 802.15.4e wireless sensor networks," *Computer Standards & Interfaces*, vol. 52, pp. 63–70, 2017.
- [63] J. Zhou, A. E. Khafa, R. Vedantham, R. Nuzzaci, A. Kandhalu, and X. Lu, "Comparison of ieee 802.15.4e mac features," in *2014 IEEE World Forum on Internet of Things (WF-IoT)*, pp. 203–207, IEEE, 2014.
- [64] H. Kurunathan, R. Severino, A. Koubaa, and E. Tovar, "Towards worst-case bounds analysis of the ieee 802.15.4e," in *2016 IEEE Real-Time and Embedded Technology and Applications Symposium (RTAS)*, p. 51, IEEE, 2016.
- [65] J.-Y. Le Boudec and P. Thiran, *Network calculus: a theory of deterministic queuing systems for the internet*, vol. 2050. Springer Science & Business Media, 2001.
- [66] J. B. Schmitt and U. Roedig, "Sensor network calculus—a framework for worst case analysis," in *International Conference on Distributed Computing in Sensor Systems*, pp. 141–154, Springer, 2005.
- [67] J. B. Schmitt, F. A. Zdarsky, and L. Thiele, "A comprehensive worst-case calculus for wireless sensor networks with in-network processing," in *Real-Time Systems Symposium, 2007. RTSS 2007. 28th IEEE International*, pp. 193–202, IEEE, 2007.
- [68] J. B. Schmitt and N. Gollan, "Worst case modelling of wireless sensor networks," *PIK-Praxis der Informationsverarbeitung und Kommunikation*, vol. 31, no. 1, pp. 12–16, 2008.
- [69] J. Schmitt, S. Bondorf, and W. Y. Poe, "The sensor network calculus as key to the design of wireless sensor networks with predictable performance," *Journal of Sensor and Actuator Networks*, vol. 6, no. 3, p. 21, 2017.
- [70] A. Koubaa, M. Alves, E. Tovar, and A. Cunha, "An implicit gts allocation mechanism in ieee 802.15.4 for time-sensitive wireless sensor networks: theory and practice," *Real-Time Systems*, vol. 39, no. 1, pp. 169–204, 2008.
- [71] A. Koubaa, M. Alves, and E. Tovar, "Energy and delay trade-off of the gts allocation mechanism in ieee 802.15.4 for wireless sensor networks," *International Journal of Communication Systems*, vol. 20, no. 7, pp. 791–808, 2007.
- [72] P. Jurcik, A. Koubaa, R. Severino, M. Alves, and E. Tovar, "Dimensioning and worst-case analysis of cluster-tree sensor networks," *ACM Transactions on Sensor Networks (TOSN)*, vol. 7, no. 2, p. 14, 2010.
- [73] H. Kurunathan, R. Severino, A. Koubaa, E. Tovar, et al., "Worst-case bound analysis for the time-critical mac behaviors of ieee 802.15.4e," in *13th IEEE International Workshop on Factory Communication Systems Communication in Automation (WFCS 2017)*, 31, May to 2, Jun, 2017, 2017.
- [74] D. Dujovne, T. Watteyne, X. Vilajosana, and P. Thubert, "6tisch: deterministic ip-enabled industrial internet (of things)," *IEEE Communications Magazine*, vol. 52, no. 12, pp. 36–41, 2014.

- [75] R. Sudhaakar and P. Zand, "6tisch resource management and interaction using coop," *draft-ietf-6tisch-coap-00 (work in progress)*, 2014.
- [76] IETF, "Ietf-roll, online," 2015. <http://tools.ietf.org/wg/roll>.
- [77] IETF, "6tisch, online," 2015. <https://datatracker.ietf.org/wg/6tisch/charter/>.
- [78] A. Paventhan, H. Krishna, N. Pahuja, M. F. Khan, A. Jain, *et al.*, "Experimental evaluation of ietf 6tisch in the context of smart grid," in *Internet of Things (WF-IoT), 2015 IEEE 2nd World Forum on*, pp. 530–535, IEEE, 2015.
- [79] S. Duquennoy, B. Al Nahas, O. Landsiedel, and T. Watteyne, "Orchestra: Robust mesh networks through autonomously scheduled tsch," in *Proceedings of the 13th ACM Conference on Embedded Networked Sensor Systems*, pp. 337–350, ACM, 2015.
- [80] A. Dunkels, O. Schmidt, N. Finne, J. Eriksson, F. Österlind, and N. T. M. Durvy, "The contiki os: The operating system for the internet of things," *Online*, at <http://www.contikios.org>, 2011.
- [81] M. Doddavenkatappa, M. C. Chan, and A. L. Ananda, "Indriya: A low-cost, 3d wireless sensor network testbed," in *International Conference on Testbeds and Research Infrastructures*, pp. 302–316, Springer, 2011.
- [82] T. Datasheet, "Crossbow inc," 2013.
- [83] X. Vilajosana, Q. Wang, F. Chraim, T. Watteyne, T. Chang, and K. S. J. Pister, "A realistic energy consumption model for tsch networks," *IEEE Sensors Journal*, vol. 14, pp. 482–489, Feb 2014.
- [84] A. M. Mehta and K. S. Pister, "Warpwing: A complete open source control platform for miniature robots," in *Intelligent Robots and Systems (IROS), 2010 IEEE/RSJ International Conference on*, pp. 5169–5174, IEEE, 2010.
- [85] A. Cunha, A. Koubaa, R. Severino, and M. Alves, "Open-zb: an open-source implementation of the ieee 802.15. 4/zigbee protocol stack on tinys," in *2007 IEEE International Conference on Mobile Adhoc and Sensor Systems*, pp. 1–12, IEEE, 2007.
- [86] F. Österlind, "A sensor network simulator for the contiki os," *SICS Research Report*, 2006.
- [87] A. Dunkels, B. Gronvall, and T. Voigt, "Contiki-a lightweight and flexible operating system for tiny networked sensors," in *Local Computer Networks, 2004. 29th Annual IEEE International Conference on*, pp. 455–462, IEEE, 2004.
- [88] S. McCanne, S. Floyd, K. Fall, K. Varadhan, *et al.*, "Network simulator ns-2," 1997.
- [89] O. Developer, "Omnet++ network simulation frame-work."