

# Fuzzy Logic Controlled AC to AC Converter FED Three Phase P.M.S.M Drive

G. Kavitha, Y. Mohamed Shuaib

**Abstract:** *The study demonstrates the simulation of distinct strategies of control applicable for an AC-AC Boost-converter based on a p.m.s.m drive for industrial automation and traction. A non varying voltage feeding a circuit of inverter with an implementation following a strategy of voltage based control, which takes into consideration of speed (mechanical) of the motor. This strategy is observed to control the voltage output of a converter on AC-DC. At the input side a boost converter is connect which incorporates an open as well as closed loop control. The controllers utilised for such conversion are PI and FLC. A VSIPMSM is modelled, simulated using a MAT Lab tool and the outcomes are compared to check the performance of both the controllers. Results predicts that there is an enhanced dynamic response in addition to an increased voltage gain for an FLC based Boost converter control rather than a PI based boost converter control..*

**Keywords:** *PWM Technique; Voltage source Inverter; Permanent-Magnet Synchronous-Motor; PI & FLC controllers; Boost-converter.*

## I. INTRODUCTION

The most challenging aspect of choosing the power converter especially for an industrial application relying a medium voltage control lies for a Boost converter-VSI circuit. In the past research towards the R and D field the major field which has proven to be a self-motivated one is the Boost converter-VSI strategy. Numerous processes on engineering focussed majorly on the the level of power utilized in devices namely semiconductors, control techniques, converters etc in reducing the cost involved in production[1]. In the current scenario the Boost-VSI has numerous benefits namely minimized losses on switching, THD, EMI, boosting the output voltage, quality improvement of power and enhancement of efficiency in a circuit[2]. Also it has an added benefit of extending its application in PFC systems for application requiring a high power[3]. VSI are hence suitable for various power levels namely high power as well as high voltage drives. The proposed Boostconverter-VSI model thus overcomes the various limitation existed in the previous suggested models for the similar kind of applications involving a CSI or conventional inverter. Another kind of Boostconverter, linking the topology of VSI and DC(isolated) was suggested earlier in research[4]. Converter involves an voltage source for drive relying on a medium level of voltage. A new strategy of PWM applied to VSI was

explored by Zhu. et al[5-7]. Sara investigated upon a strategy on PWM(multi) carrier based VSI[8]. Kawahashi introduced a HEV based new techniques with the incorporated power devices namely semiconductors[9-11]. Asano explored a motor based load technique proved to perform high for a HEV system[12]. Esima investigated on a system utilising a P.M.S.M based analysis during fault occurrence in inverters[13]. Cardoso carried his study in suggesting a performance measurement techniques for a P.M.S.M drive[14]. Ajoy investigated and presented a vector related technique for control of P.M.S.M. The study included an elaborate modelling strategies with respect to P.M.S.M and the control of speed was performed through a vector related approach including a S.F.B( State-feedback-Controller). The requirement of sensor was completely eliminated by an observer. The observer thus calculate the state variable which is un known by the use of other state variable thereby removing the sensors need for both sensing voltage and current. A zero steady state error is achieved by the controller S.F.B[15]. Caro conducted his study on PFC and contributed a new driver for a signal control in various ranges. The new STNRGPF01 device towards a I.P.F.C(Interleaved- Boost- PFC- converters) was proved to show better results. This driver is capable driving 3 channels of digitally ASIC configurable works at C.C.M(Continuous-Conduction-Mode) at a non varying frequency associated with a control of A.C.M(Average- Current- Mode). The configuration for the above was made through suite on e-designing in order to get customised for a particular application. The suggested setup was experimentally verified under 3 kw 3 channel board of I.P.F.C[16]. Latha explored a technique for a new model on five level- NP clamped (5L-NPC) based inverter to feed a Induction motor load working under medium voltage level application for I.P.F.C. Reduced harmonics was observed in the suggested model of prototype showing flexibility of a z sourced inverter of multilevel in establishing an AC voltage (ideal source) with an association of DC voltage(little). Buck and boost capability got accomplished by a network of Z source aimed at uniting inverter with DC source at the input side[17]. Investigations towards integrating a Dual mode 3 phase drive on P.M.S.M with hybrid energy based storage system(H.E.S.S) contributed by Wei. Enhancing the performance as well as to integrate the EH-power train a detailed study was carried out on H.E.S.S system for power control.

**Revised Manuscript Received on July 13, 2019**

**G. Kavitha**, Research Scholar, EEE Department, B.S. Abdur Rahman Crescent Institute of Science and Technology, Chennai. E-mail: kavithakumara@gmail.com

**Y. Mohamed Shuaib**, Associate Professor, EEE Department, B.S. Abdur Rahman Crescent Institute of Science and Technology, Chennai. E-mail: mdshuaiby@gmail.com

# Fuzzy Logic Controlled AC to AC Converter FED Three Phase P.M.S.M Drive

Motor windings with a set of 2 got connected with that of UCs and with that of battery via the inverters. Fore mostly the working modes of the integrated system was undergone trough the analysis of vector diagram and modelling. A novel strategy to establish the regulation improvement techniques was conducted for an unbalanced system of power distribution[18].

H bridge- transistor- clamped cascaded multiple levelled inverter incorporating a new technique on balancing the voltage on a capacitor was contributed by Fathi. Another technique on balancing the voltage of capacitor on midpoint level was conducted. The harmonic level analysis at the output voltage along with the analysis on total losses of power including the switching as well as conduction losses was compared and conferred with a cascaded N.P.C and a conventional cascaded inverter on H bridge. In order to verify the outcomes of the above suggested system the setup was tested on an induction motor[19]. Madjid berkouk explored a rectifier circuit using 5 level PWM+ 5 level N.P.C of active power filter utilising a feedback based control[20].

## II. RESEARCH GAP

Boost converter-VSI P.M.S.M strategy utilising a Fuzzy logic based controller for a closed loop system was yet to be addressed towards power quality improvement in the previous research studies. Here in this study Fuzzy logic is used for various disturbances namely for variations in voltage or load. The suggested work makes comparison on the response of VSI P.M.S.M drive with PI as well as FLC controller under the condition of closedloop. The Mat Lab outcomes predicts the values of time domain parameters.

## III. FUZZY LOGIC CONTROLLER

Over the years machines are replacing the manual work. But expert languages have tried to make a substitution for the conventional controller namely P.I.D which is the one majorly used by almost all the industries. They are familiar for their ease control strategy on parameters. Recently FLC are over gaining the attention with all other controllers as these controllers are capable of thinking and making decisions similar to human beings which are always acceptable at all the levels of the society suggested by Podlubny.

## IV. SYSTEM DESCRIPTION

The block diagram of existing open loop system is shown in Fig1. Input AC is rectified and it is boosted using boost-converter. The output of BC is delivered to the TPVSI.

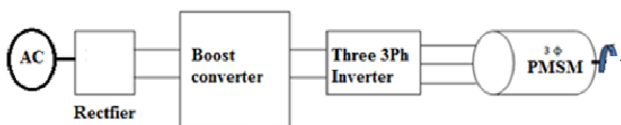

Fig1. Block diagram of existing open loop PMSM system

In Fig.2 Converters AC and DC are combined towards enhancing the voltage output(DC).The current speed is compared with the speed under reference.The voltage error is fed to controller(FLC).The controller in turn controls the variations to improve the power quality of the system by reducing the disturbances.A comparison was presented among the FLC and PI controllers.

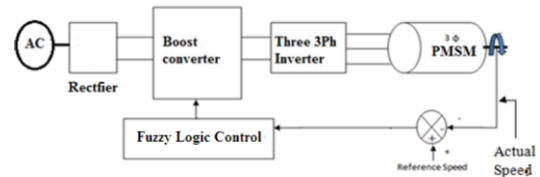

Fig 2. Block-diagram of the proposed VSIPMSM system

## V. RESULTS AND DISCUSSIONS

### A. Open loop VSIPMSMD system with torque load

In Fig 3.1 VSI P.M.S.M system working under open loop was presented. In Fig 3.2 the speed of the motor with changes in voltage was predicted as 1550 RPM.The Fig 3.3 shows the open loop based torque value as 0.4 N-m

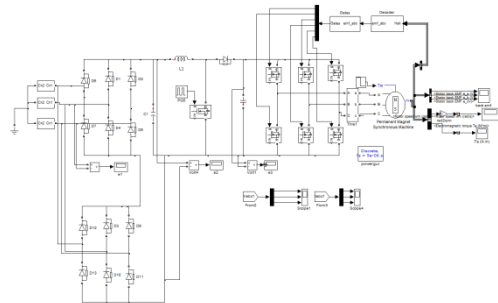

Fig.3.1.Circuit diagram of Open loop system with torque load

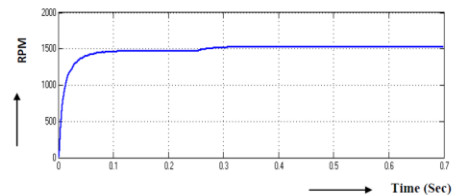

Fig.3.2.Motor speed

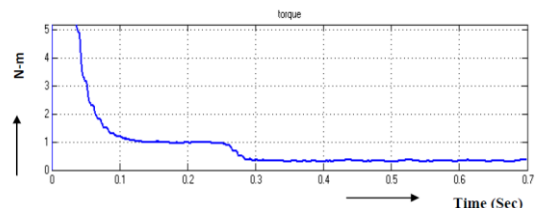
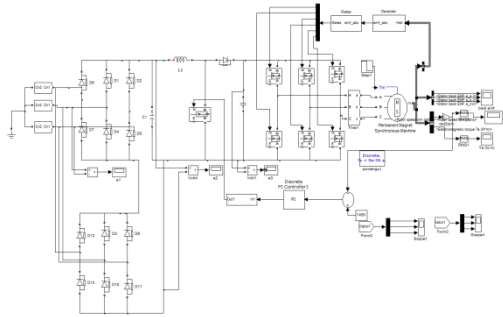

Fig.3.3.Torque Response

**B. Closed loop VSIPMSMD system with PI controller**

Fig .4.1 shows a Closed mode control of VSI P.M.S.M using a controller of PI, with the speed of motor in Fig 4.2 as 1450 R.P.M. The regulation of speed is achieved by means of controller PI. The value of torque is predicted as 0.2 N-m in Fig 4.3.



**Fig.4.1.Closed loop VSIPMSMD system of PI controller**

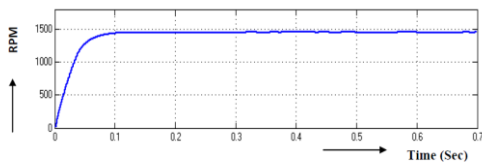

**Fig.4.2.Motor speed**

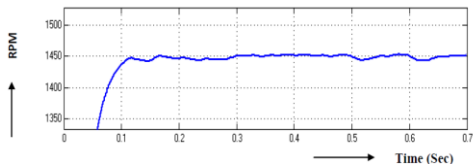

**Fig.4.2a.Zoomed view of Motor speed**

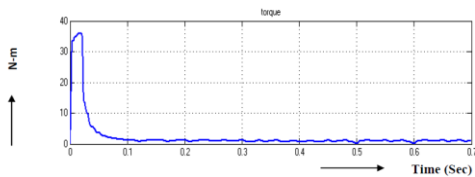

**Fig.4.3.Torque Response**

**C. Closed loop VSIPMSMD system with FLC controller**

The circuit diagram of the closed loop VSIPMSMD system with FLC controller is shown in Fig.5.1. Motor speed of the closed loop VSIPMSMD system with FLC controller is shown in Fig.5.2 and its value is 1450 RPM. The speed is regulated using PI controller. Torque of the closed loop VSIPMSMD system with FLC controller is shown in Fig.5.3 and its value is 0.2 N-m.

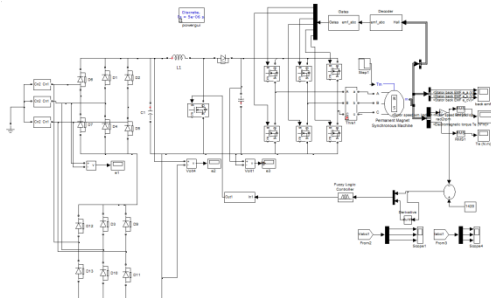

**Fig.5.1.Closed loop PMSMD system with FLC controller**

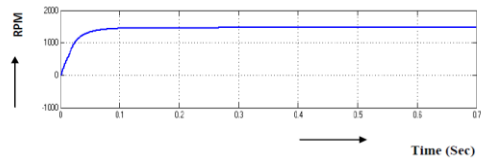

**Fig.5.2.Motor speed**

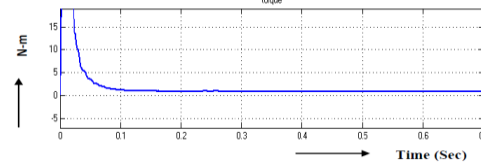

**Fig.5.3.Torque Response**

Comparison of time domain parameters of the closed loop VSIPMSMD system with PI and FLC is shown in Table- 1. By using FLC controller, real time is reduced from 0.27sec to 0.05 sec ; settling time is reduced from 0.50sec to 0.15sec ; peak time is reduced from 0.43sec to 0.13 sec ; steady state error is reduced from 3.3 V to 0.7 V. Hence, closed loop PMSMD system with FLC controller is superior to that of the closed loop VSIPMSMD system with PI controller. Dynamic response is improved by using closed loop VSIPMSMD system with FLC controller.

**Table-1 Comparison of Time domain parameters with PI and FLC**

Controllers	T <sub>r</sub> (sec)	T <sub>s</sub> (sec)	T <sub>p</sub> (sec)	E <sub>ss</sub> (volts)
PI	0.27	0.50	0.43	3.3
FLC	0.05	0.15	0.13	0.7

**VI. EXPERIMENTAL RESULTS**

The Hardware snap shot for VSIPMSM system is shown in Fig 6.1. The hardware consists of rectifier, converter, Boost Converter, Transformer, Control Circuit, inverter and motor load. The input voltage is shown in Fig 6.2. The Output voltage of boost converter is shown in Fig 6.3.

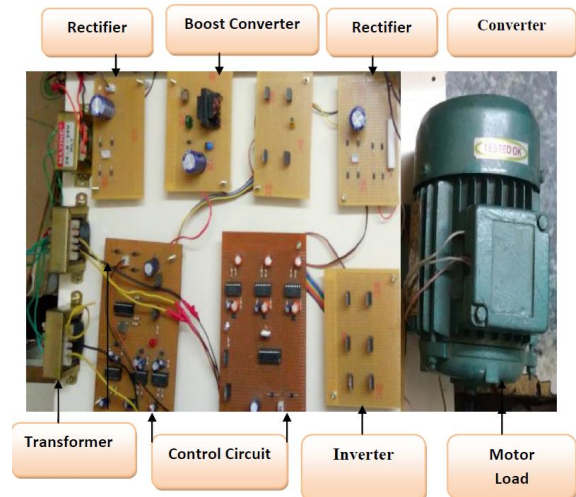

**Fig 6.1 Hardware snap shot of VSIPMSM**



## Fuzzy Logic Controlled AC to AC Converter FED Three Phase P.M.S.M Drive

The Switching pulses for M1 and M3 of inverter are shown in Fig 6.4. The Switching pulse for M2 and M6 of inverter are shown in Fig 6.5. The Output voltage of inverter is shown in 6.6. The simulation- results of previous section match with the experimental- results.

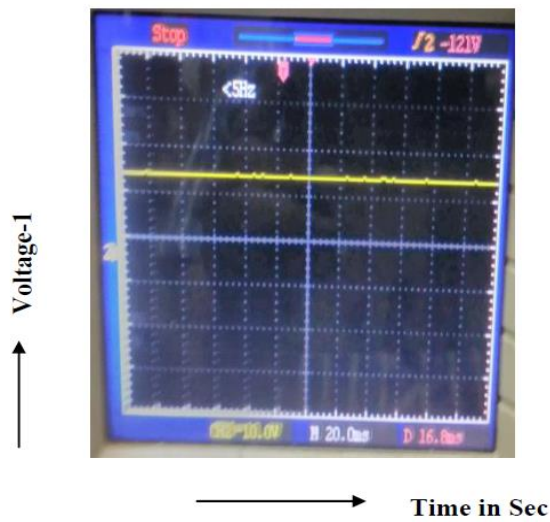

Fig 6.2 Input voltage

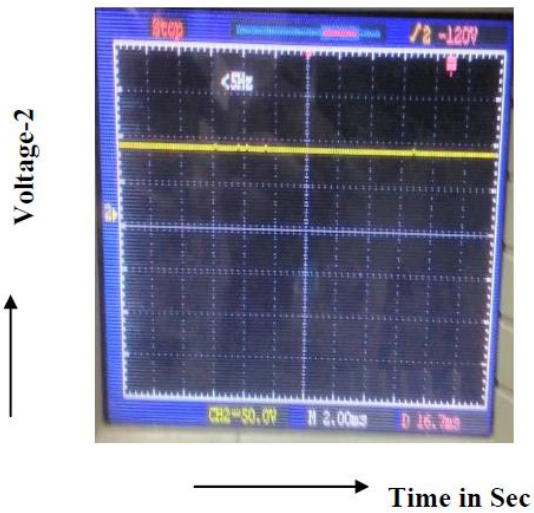

Fig 6.3 Output voltage of boost converter

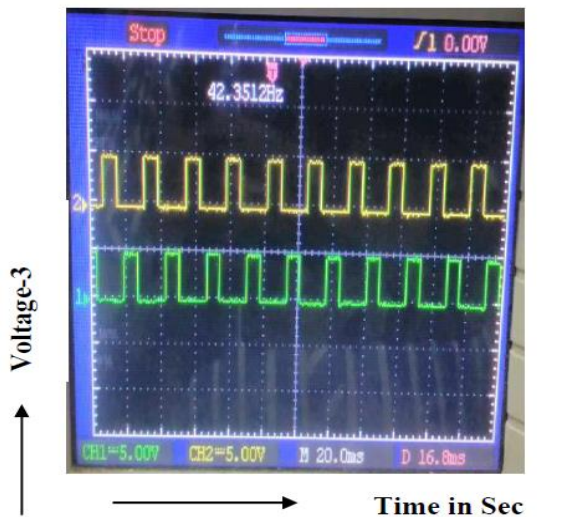

Fig 6.4 Switching pulses for M1 & M3 of inverter

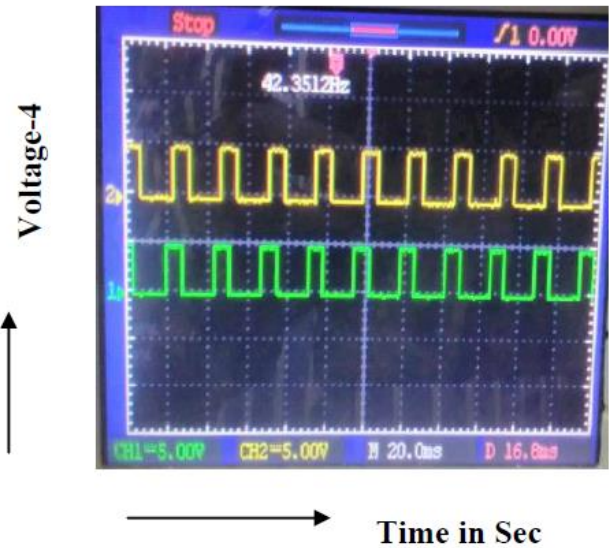

Fig 6.5 Switching pulses for M2&M6 inverter

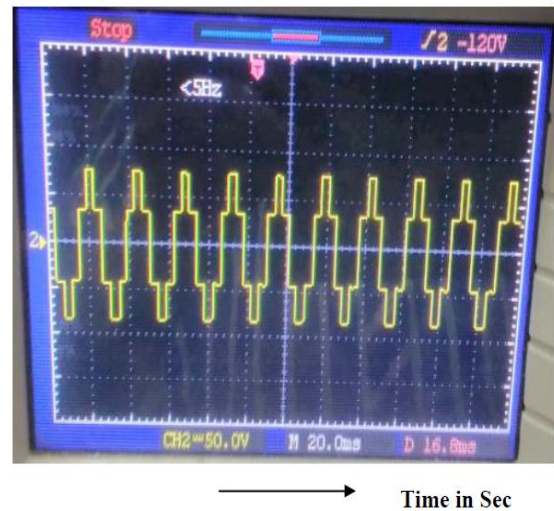

Fig 6.6 Output voltage of inverter

## VII. CONCLUSION

The Boost converter-VSI P.M.S.M was designed and simulated. The output for PI controller was compared to the output of FLC. The changes of voltage output with variations in frequency were presented. The time of settling by using FLC is 0.50 seconds and the ess(error under steady state) was 3.3 RPM). Hence FLC is found to show very good performance than a PI controller for a VSI P.M.S.M based drive system. With varying reference speed the time domain parameters are measured and are observed that the time of settling reduces with that of reference speed. Thus the power quality improvement in the Boost converter based VSI P.M.S.M was implemented which in turn minimizes the total harmonic distortion thereby an improved power quality.

### Appendix A

The values of different components used in figure 3.1 to which simulation is performed are given here:



$V_{in}$	100V
$L_1$	0.35mH
$C_1$	1000 $\mu$ F
$C_2$	200 $\mu$ F
MOSFET(IRF840)	500V/8A
DIODE	230V/1A
$V_0$	415V

### Appendix B

The parameters of the motor shown in figure 3.1 are given below:

$V_{in}$	415V
$R_s$	2.87 $\Omega$
$L_s$	8.5mH
Flux magnets	0.175
Back emf	120°

### REFERENCES

1. C. C. Chan, A. Bouscayrol and K. Chen, "Electric, hybrid, and fuelcell vehicles: architectures and modeling", *IEEE Transactions on Vehicular Technology*, vol. 59, no. 2, pp. 589-598, February 2010.
2. A. Emadi, Y. J. Lee and K. Rajashekar, "Power electronics and motor drives in electric, hybrid electric, and plug-in hybrid electric vehicles", *IEEE Transactions on Industrial Electronics*, vol. 55, no. 6, pp. 2237-2245, June 2008.
3. K. T. Chau, C. C. Chan and L. Chunhua, "Overview of permanent magnet brushless drives for electric and hybrid electric vehicles", *IEEE Transactions on Industrial Electronics*, vol. 55, no. 6, pp. 2246-2257, June 2008.
4. M. Zeraouia, M. E. H. Benbouzid and D. Diallo, "Electric motor drive selection issues for HEV propulsion systems: a comparative study", *IEEE Transactions on Vehicular Technology*, vol. 55, no. 6, pp. 1756-1764, November 2006.
5. Z. Q. Zhu and D. Howe, "Electrical machines and drives for electric, hybrid, and fuel cell vehicles", *Proceedings of the IEEE*, vol. 95, no.4, pp. 746-765, April 2007.
6. José Rodriguez: Steffen Bernet: BinWu: Jorge, O Pontt: Samir Kouro. Voltage source- converter topologies for industrial medium-voltage drives.*IEEE transactions on industrial electronics* 2007, Volume 54, pp. 2930-2945.
7. Jing Zhao: Xiangning He: Rongxiang Zhao. A novel PWM control method for voltage source inverters.*IEEE transactions on industrial electronics* 2010, Volume 57, pp.2365-2373.
8. Sara Laali: Karim Abbaszadeh: Hamid Lesani. Development of multi-carrier PWM technique of voltage source inverters.*International conference on Electrical Machines and Systems (ICEMS)*, Incheon, 10-13 Oct. 2010.
9. Fang Zheng Peng: Alan Joseph: Jin Wang: Miaosen Shen: Lihua Chen: Zhiguo Pan: EduardoOrtiz Rivera: Yi Huang. VSI for motor drives.*IEEE transactions on power electronics* 2005, Volume20, pp. 857-863.
10. M. Shen and F. Z. Peng, "Converter systems for hybrid electric vehicles", *International Conference on Electrical Machines and Systems*, pp. 2004-2010, 8-11 October, 2007
11. A. Kawahashi, "A new-generation hybrid electric vehicle and its supporting power semiconductor devices", *International Symposium on Power Semiconductor Devices and ICs*, pp. 23-29, 24-27 May, 2004.
12. K. Asano, Y. Inaguma, H. Ohtani, E. Sato, M. Okamura and S. Sasaki, "High performance motor drive technologies for hybrid vehicles", *Power Conversion Conference*, pp. 1584-1589, 2-5 April, 2007.
13. J. O. Estima and A. J. M. Cardoso, "Performance analysis of permanent magnet synchronous motor drives under inverter fault conditions", *XVIII International Conference on Electrical Machines*, Vilamoura, Portugal, 6 pp., 6-9 September, 2008.
14. J. O. Estima and A. J. M. Cardoso, "Impact of inverter faults in the overall performance of permanent magnet synchronous motor drives", *IEEE International Electric Machines and Drives Conference*, Miami, FL, USA, pp. 1319-1325, 3-6 May, 2009.
15. Ajoy Kumar Chakraborty, Navonita Sharma " Control of permanent magnet synchronous motor (pmsm) using vector control approach "

- Transmission and Distribution Conference and Exposition (T&D)*, 2016 IEEE/PES.
16. Sebastiano Messina, Marco Torrisi, Giuseppe Di Caro, "A New Driver for Interleaved PFC Based on Mixed Signal Control" PCIM Europe 2017; International Exhibition and Conference for Power Electronics 16-18 May 2017.
  17. Mohamed Yousuf , and Latha "Analysis and Design of Multicarrier PWM Based Multilevel Z-Source Inverter Fed Induction Motor Drives with DTC" 5 February 2014.
  18. Sideng Hu, Zipeng Liang, Wei Zhang, Xiangning He "Research on the Integration of Hybrid Energy Storage System and Dual Three-Phase PMSM Drive in EV" IEEE Transactions on Industrial Electronics ( Volume: PP, Issue: 99 ) 13 September 2017.
  19. Nasrudin Abd Rahim; Mohamad Fathi; Mohamad Elias; Wooi Ping Hew. Transistor-clamped H-bridge based cascaded multilevel inverter with new method of capacitor voltage balancing. *IEEE transactions on industrial electronics* 2013, Volume 60, pp. 2943-2956.
  20. Thameur Abdelkrim: El Madjid Berkouk: Karima Benamrane: Tarak Benslimane. Study and control of 5-level PWM rectifier-5-level NPC active power filter cascade using feedback control and redundant vectors. *Turkish Journal of Electrical Engineering & Computer Sciences* 2012, Volume 20, pp. 655-677.

### AUTHOR INFORMATION:



Mrs. Kavitha.G was born in the year 1979. She obtained B.E Electrical and Electronics Engineering from Madras University in 2001. She got her P.G degree in M.E (Applied Electronics) from Madras University in the year 2002. She is currently pursuing Ph.D in Power Electronics and drives in the Department of Electrical and Electronics Engineering at B.S.Abdur Rahman Crescent Institute of Science and Technology. Her area of interests includes electrical machines and drives.



Y. Mohamed Shuaib received his B.E in Electrical and Electronics Engineering from University of Madras in 1994 and his M.E. in Power System Engineering from Annamalai University, Tamilnadu, India, in 2002. He obtained his Ph.D degree from Jawaharlal Nehru Technological University, Hyderabad, India in 2015. He has teaching experience of more than 16 years. He is currently working as Associate Professor in the department of Electrical and Electronics Engineering in B.S.Abdur Rahman Crescent Institute of Science and Technology, Chennai, Tamil Nadu, India. His research area includes Reactive Power Compensation, Power System Control, Power Quality and Application of Optimization Techniques in Power Systems.