

A PREPROCESSING METHOD FOR PAPR REDUCTION IN OFDM SYSTEMS BY MODIFYING FFT AND IFFT MATRICES

Keyvan Kasiri¹, Iraj Hosseini¹, Omid Taheri¹, Mohammad Javad Omid¹, P. Glenn Gulak²

¹ECE Department, Isfahan University of Technology

²ECE Department, University of Toronto

ABSTRACT

In this paper we propose an algorithm for PAPR reduction in OFDM systems, based on a modification in the IFFT matrix at the transmitter and using the inverse matrix at the receiver. In this method two columns of the IFFT matrix are replaced with a linear combination of them in order to reduce the PAPR. These columns correspond to the maximum and minimum in the sequence of absolute values for each OFDM symbol. It will be shown that we may choose more than one pair in order to reduce the PAPR more effectively. The proposed method entails less complexity at the transmitter in comparison with other PAPR reduction algorithms. It also requires less increase in SNR for the same BER compared to other methods. A trade-off between complexity and system performance can set the number of pairs of maximum and minimum processed. The only drawback of this method is that the modified IFFT matrix is not the same for all OFDM symbols; therefore some extra information about the modified matrix must be sent.

I. INTRODUCTION

Recently, Orthogonal Frequency Division Multiplexing (OFDM) signalling has been widely used for high data rate transmission applications, due to its high spectral efficiency and robustness to the frequency selective fading channels [1]. One major drawback of OFDM is the high peak-to-average power ratio (PAPR) of the output signal. Transmitting a signal with high PAPR requires highly linear power amplifiers with a large back-off to avoid adjacent channel interference due to nonlinear effects [2]. High values of PAPR result in low efficient usage of the ADC and DAC word length. With a limited number of ADC/DAC bits the designer has to decide about clipping the peaks, which results in burying the small variations of the signal in the quantization noise. Therefore, dynamic range reduction plays an important role for the application of OFDM signals in both power and band-limited communication systems.

Many PAPR reduction techniques have been proposed in the literature. It should be noted that most of the methods are based on the same idea of selecting the time domain signal to be transmitted from a set of different representations with the constraint of minimization of PAPR which would degrade the performance of system. Nevertheless, PAPR reduction methods can be classified into distortionless and distortion techniques.

Distortion techniques are considered to introduce spectral regrowth. They do not require any side information to be sent and they have low complexity compared to the distortionless techniques with the drawback of increase in the error rate of the system. Here the simplest method is to clip the peak amplitude of the OFDM signal to some desired maximum

level but it is an irreversible nonlinear process which will cause an unacceptable level of noise and out of band distortion [3, 4]. Although spectrum interference can be reduced by filtering, the process causes peak regrowth. Another effective method is companding that reduces the PAPR with low complexity at the cost of a loss in SNR [5, 6]. Using this technique, small signals are enlarged, while the large ones remain unchanged. However, the average power of amplifier-input signals is increased, which makes it more sensitive to the nonlinearity of the power amplifier. Since all the companding techniques are sensitive to channel noise, due to the nonlinear processing, more PAPR reduction could lead to lower performance. Increase in out-of-band distortion is another drawback with this technique.

On the other hand, distortionless techniques do not introduce spectral regrowth. But they require sending side information to the receiver and in some cases increase the error rate of the system. Coding techniques use a forward-error-correction code set to exclude the OFDM symbols with a high PAPR such as block coding [7] and turbo coding [8]. Most of them add substantial complexity at the transmitter, and require significant coding overhead. Another method namely Phase Optimization tries to reduce the peaks by properly rotating channel constellation. Two recently introduced Phase Optimization methods are the Partial Transmit Sequence (PTS) [9] and Selected Mapping (SLM) [10]. A drawback of these methods is high computational cost at the transmitter and extra information sent to the receiver. Some other proposed methods in this category are Tone Injection [11], Tone Reservation [12], and Active constellation Extension [13].

In this paper, we propose a novel method, which tries to reduce the PAPR through modifying the IFFT matrix in the transmitter. In section II, the signal model and the PAPR problem are explained. Section III introduces the new matrix as the replacement of IFFT matrix and formulation for its inverse. The detailed simulation results and discussion are given in section IV. Finally we will conclude in section V.

II. OFDM SYSTEM MODEL AND PAPR PROBLEM

In an OFDM system a frequency bandwidth B is divided into N non-overlapping orthogonal subcarriers of bandwidth Δf ; where $B = N\Delta f$. For a given OFDM symbol, each subcarrier is modulated with a complex value taken from a known constellation (e.g. QAM, PSK, etc.). Let us denote a block of N frequency domain subcarriers as a vector $X = [X_0, X_1, \dots, X_{N-1}]$. In the time domain, via an IFFT operation we obtain $x = [x_0, x_1, \dots, x_{N-1}]$. Thus, the sampled sequence is:

$$x[n] = \frac{1}{N} \sum_{k=0}^{N-1} X[k] e^{j2\pi kn/N}, \quad 0 \leq n < N \quad (1)$$

Equivalently the above relation can be expressed in matrix form as $x = XW$, where W is as follows:

$$W = \begin{bmatrix} 1 & 1 & \dots & 1 \\ 1 & e^{j2\pi/N} & \dots & e^{j2\pi(N-1)/N} \\ \vdots & \vdots & \ddots & \vdots \\ 1 & e^{j2\pi(N-1)/N} & \dots & e^{j2\pi(N-1)(N-1)/N} \end{bmatrix} \quad (2)$$

IFFT matrix can be represented by its columns:

$$W = [W_0 \ W_1 \ \dots \ W_{N-1}] \quad (3)$$

The PAPR is a figure of merit that describes the dynamic range of the OFDM time domain signal. The conventional definition of the PAPR for the OFDM symbol in the time domain x may be expressed as:

$$PAPR(x[n]) = \frac{\max|x[n]|^2}{E[|x[n]|^2]} \quad (4)$$

where $E[\cdot]$ denotes expected value of a random variable.

III. PAPR REDUCTION USING MODIFIED FFT/IFFT MATRICES

In this section we propose a new technique based on modifying the FFT/IFFT matrices. Using the modified matrix, the maximum and minimum of the time domain signal is replaced by the linear combination of them. In this method, peak of the signal will be reduced while the average is kept constant. In the following, the new matrix and its inverse form are introduced. This method will require transmission of some extra information from transmitter to the receiver, which will be addressed in the next section. In the last subsection of this section we will consider some implementation issues which make the design simpler.

A. The Proposed Method

The method presented in this paper keeps the average of the time domain signal constant while trying to reduce its peak. Consider the set of time domain samples $[x_0, x_1, \dots, x_{N-1}]$ of a single OFDM symbol, where N is the FFT size employed. Let p and q denote the indices of maximum and minimum in the sequence $[|x_0|, |x_1|, \dots, |x_{N-1}|]$ respectively. To reduce the PAPR effectively, it may be useful to replace these two time domain samples with new ones which are a linear combination of them. This modification inherits the row orthogonality feature from the IFFT matrix. This procedure is simply equivalent to modifying the corresponding two columns of the original IFFT matrix. Assume that x'_p and x'_q denote the modified samples, which can be obtained from:

$$\begin{aligned} x'_p &= c_{pp}x_p + c_{pq}x_q \\ x'_q &= c_{qp}x_p + c_{qq}x_q \end{aligned} \quad (5)$$

where coefficients c_{pp} , c_{pq} , c_{qp} , and c_{qq} are real values. Let T be the modified IFFT matrix such that $T = [T_0, T_1, \dots, T_{N-1}]$, where T_i represents the i th column of T . Equivalently,

$$\begin{aligned} T_p &= c_{pp}W_p + c_{pq}W_q \\ T_q &= c_{qp}W_p + c_{qq}W_q \end{aligned} \quad (6)$$

In the next subsection, we will apply some constraints on the T matrix in order to compute coefficients c_{pp} , c_{pq} , c_{qp} , and c_{qq} . It will be shown that these constraints result in the appropriate coefficients, keeping the average of the preprocessed signal constant.

Consider the sequence $[|x_0|, |x_1|, \dots, |x_{N-1}|]$ representing the absolute values of the OFDM symbol sequence. The optimum solution to reduce the PAPR is to perform the following replacement:

$$|x'_p| = |x'_q| = 0.5|x_p| + 0.5|x_q| \quad (7)$$

In this case, the average of the signal is kept constant while the maximum of the signal moves from the p index to another position which results in PAPR reduction.

The mentioned method is optimal if we could find a solution for c_{pp} , c_{pq} , c_{qp} , and c_{qq} , that x'_p and x'_q resulting from (5) satisfy (7). It can be seen mathematically that the optimal values for c_{pp} , c_{pq} , c_{qp} , and c_{qq} is dependent to the signal x . Consequently, there is no optimal solution to this problem.

To achieve more reduction in PAPR of the signal, it is possible to use multiple pairs of maximum and minimum instead of using just one in the above discussion. As an instance, by using M pairs instead of one pair of maximum and minimum, (5) and (6) introduced above can be generalized as follows:

$$\begin{aligned} x'_{p_i} &= c_{pp}x_{p_i} + c_{pq}x_{q_i} \\ x'_{q_i} &= c_{qp}x_{p_i} + c_{qq}x_{q_i} \\ i &= 1, 2, \dots, M \end{aligned} \quad (8)$$

$$\begin{aligned} T'_{p_i} &= c_{pp}W_{p_i} + c_{pq}W_{q_i} \\ T'_{q_i} &= c_{qp}W_{p_i} + c_{qq}W_{q_i} \\ i &= 1, 2, \dots, M \end{aligned} \quad (9)$$

Fig. 1 shows the system model considered in this paper.

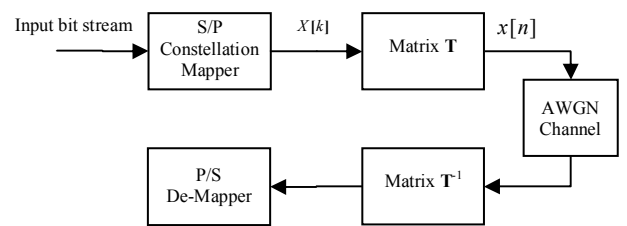

Figure 1: The considered system block diagram.

Fig. 2 shows the resulting signal after being modified by the T matrix via 1, 2, 3, and 4 pairs of maximum and minimum. In the first step we process the first pair of maximum and minimum of the signal. After that, in each step by suppressing the next maximum of the signal, peak of the signal will be reduced more which leads to further reduction in PAPR. Solid line shows the resulting signal after preprocessing algorithm and dotted one shows the original signal.

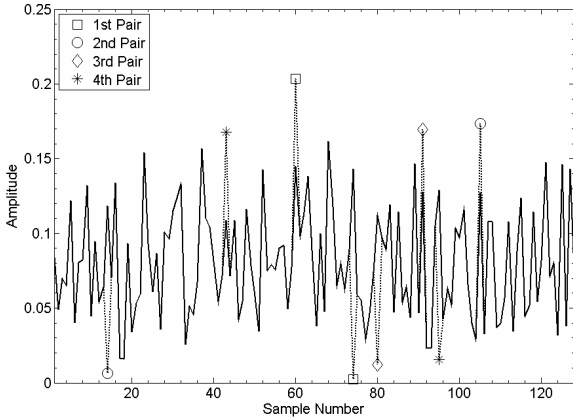

Figure 2: Modifying the signal through 1, 2, 3 and 4 pairs of extreme points.

In the following subsection we will find some restrictions imposed on c_{pp} , c_{pq} , c_{qp} , and c_{qq} , and a general form for \mathbf{T} matrix and its inverse which is required for detecting the signal in the receiver.

B. General Form for the Matrix \mathbf{T} and Its Inverse

The matrix \mathbf{T} defined above must have a unique inverse in order to make signal detection possible at the receiver side. From basic algebra it is well known that a full rank matrix has a nonzero determinant and as a result is invertible. A matrix with orthogonal rows is a special case of a full rank matrix. So as a first restriction for the matrix \mathbf{T} it is necessary for that to maintain the row orthogonality of the original IFFT matrix. In other words, for two arbitrary different rows l and m :

$$\sum_{i=0}^{N-1} T_i(l)T_i(m) = 0 \quad (10)$$

which finally results in

$$\begin{aligned} c_{pp}^2 + c_{qp}^2 &= 1 \\ c_{pq}^2 + c_{qq}^2 &= 1 \\ c_{pp}c_{pq} + c_{qp}c_{qq} &= 0 \end{aligned} \quad (11)$$

From the above equations it is deduced that for the i th row of the matrix,

$$W_p^2(i) + W_q^2(i) = T_p^2(i) + T_q^2(i), \quad i = 0, 1, 2, \dots, N-1 \quad (12)$$

This leads to maintain the energy of the rows of the matrix \mathbf{T} as those of the IFFT matrix. Since all rows of the IFFT matrix and the matrix \mathbf{T} have equal energy, the system employing \mathbf{T} as a replacement for the IFFT matrix consumes equal power as the original OFDM system to send data.

It is desirable to use a matrix at the transmitter whose inverse can be attained through a generic formulation. If c_{pp} , c_{pq} , c_{qp} , and c_{qq} coefficients satisfy the following criteria in addition to (11),

$$\begin{aligned} c_{pp}^2 + c_{pq}^2 &= 1 \\ c_{qp}^2 + c_{qq}^2 &= 1 \\ c_{pp}c_{qp} + c_{pq}c_{qq} &= 0 \end{aligned} \quad (13)$$

the inverse of \mathbf{T} can be obtained by just modifying two rows of the FFT matrix. Mathematically, it is easy to show that the matrix \mathbf{T}^{-1} can be obtained via replacing p th and q th rows of FFT matrix with their linear combination. The coefficients employed in the linear combination to generate matrix \mathbf{T}^{-1} are those used to synthesize \mathbf{T} .

$$\begin{aligned} S_p &= c_{pp} V_p + c_{pq} V_q \\ S_q &= c_{qp} V_p + c_{qq} V_q \end{aligned} \quad (14)$$

where $\mathbf{S} = (\mathbf{T}^{-1})^T$ and $\mathbf{V} = (\mathbf{W}^{-1})^T$ and $(.)^T$ denotes matrix transposition operator.

Assume $\mathbf{R} = \mathbf{T}^{-1}\mathbf{T}$. In order to prove that $\mathbf{R} = \mathbf{I}_N$, where \mathbf{I}_N is the N by N identity matrix, it is sufficient to state that:

$$\begin{aligned} \mathbf{R}(p,q) &= \mathbf{R}(q,p) = 0, \\ \mathbf{R}(p,p) &= \mathbf{R}(q,q) = 1. \end{aligned} \quad (15)$$

Defining $\mathbf{U} = \mathbf{W}^{-1}\mathbf{W}$, It is obvious that $\mathbf{R}(i,j) = \mathbf{U}(i,j)$ for $i, j \neq p, q$. Solving (15), for $\mathbf{R}(p,q)$ and $\mathbf{R}(p,p)$ we have:

$$\begin{aligned} \frac{1}{N} \sum_{i=0}^{N-1} (c_{pp} e^{j2\pi p i / N} + c_{pq} e^{j2\pi q i / N}) (c_{qp} e^{-j2\pi p i / N} + c_{qq} e^{-j2\pi q i / N}) &= 0 \\ \frac{1}{N} \sum_{i=0}^{N-1} (c_{pp} e^{j2\pi p i / N} + c_{pq} e^{j2\pi q i / N}) (c_{pp} e^{-j2\pi p i / N} + c_{pq} e^{-j2\pi q i / N}) &= 1 \end{aligned} \quad (16)$$

We can obtain the same results for $\mathbf{R}(q,q)$ and $\mathbf{R}(q,p)$ similarly which completes the proof. Considering relations stated in (11) and (13) the coefficients should be such that:

$$\begin{aligned} c_{pp} &= \pm c_{qq} \\ c_{pq} &= \mp c_{qp} \end{aligned} \quad (17)$$

In case of using multiple pairs of maximum and minimum, similar to using one pair the inverse relation can be presented as follows:

$$\begin{aligned} S_{p_i} &= c_{pp} V_{p_i} + c_{pq} V_{q_i} \\ S_{q_i} &= c_{qp} V_{p_i} + c_{qq} V_{q_i} \end{aligned} \quad (18)$$

C. Extra Information to Be Transmitted

It is necessary for the receiver to know the location of maximum and minimum of an OFDM symbol to create correct \mathbf{T}^{-1} for demodulation. Thus, the location of maximum and minimum has to be sent for each OFDM symbol in addition to the symbol itself.

One solution to transmit this information is to use a separate channel. Another one is to devote an OFDM symbol to this information periodically, and use original IFFT/FFT matrices to transmit and detect this information which results in data-rate reduction.

D. Some Implementation Issues

It may be thought that implementation of the system model shown in Fig. 1 consumes lots of excess resources than the original OFDM system in which the matrices \mathbf{T} and \mathbf{T}^{-1} are replaced with IFFT and FFT matrices. At the first glance it is true since matrix \mathbf{T} may change from symbol to symbol. To have a less complex design in the transmitter, it would be wise to replace the \mathbf{T} matrix block in the transmitter with an IFFT block and a post-processor block. The post-processor

block is responsible for replacing two or more output samples of the IFFT matrix with a linear combination of them as in (8). We can rewrite (8) in the matrix form as follows:

$$\begin{bmatrix} x'_{p_i} \\ x'_{q_i} \end{bmatrix} = \begin{bmatrix} c_{pp} & c_{pq} \\ c_{qp} & c_{qq} \end{bmatrix} \begin{bmatrix} x_{p_i} \\ x_{q_i} \end{bmatrix} \quad (19)$$

Because of (17) the determinant of coefficient matrix becomes $c_{pp}^2 + c_{qp}^2$ which is not zero by (11) and therefore this matrix is invertible. So it is possible to retrieve the original time domain symbols from the modified ones. So it is possible to replace the T^{-1} block in the receiver with a pre-processing block and the FFT block. The pre-processor block is to recover original time domain symbols from the modified ones. This way the only excess parts of the new design comparing with the original OFDM design are the post-processor and pre-processor blocks included.

IV. SIMULATION RESULTS

To verify performance of the proposed method in PAPR reduction and the overall system performance, different experiments are performed. The simulation environment is an OFDM system and we describe its characteristics for each experiment. In the first experiment, we assess the Complementary Cumulative Distribution Function (CCDF) of PAPR plots for the original, Preprocessed signals and the signals from SLM method. Elements of SLM multiplying sequences are chosen from the set $\{\pm 1, \pm j\}$. Also, Bit Error Rate (BER) of the system for original FFT, SLM coded and obtained matrices is compared. Finally, we evaluate Power Spectral Density (PSD) of the signals. In all experiments 10^5 randomly generated signals are used for PAPR plots and 10^6 random bits are employed for the BER plots. Also, we assume $c_{pp} = \sin(\pi/4)$ and $c_{pq} = \cos(\pi/4)$.

A. Evaluation of Preprocessing Algorithm

Fig. 3 shows the CCDF of PAPR for SLM coded, original and preprocessed signals when 1, 2, 3 and 4 peaks are suppressed. Here, 16-QAM constellation is used and FFT size is chosen to be 64. The number U in this figure shows number of the multiplying sequences employed in the SLM method. As it is observed, the algorithm reduces the PAPR of the OFDM signal effectively compared to the original signal.

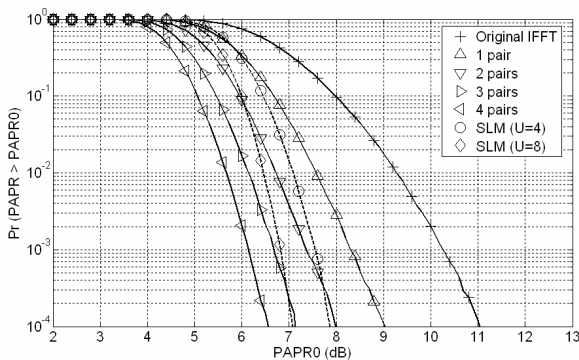

Figure 3: The CCDF of PAPR for original and preprocessed signals.

For 1, 2, 3 and 4 peaks, and for $CCDF = 10^{-4}$, the PAPR is reduced 2.1, 3.1, 4 and 4.5 dB respectively. Also, it is seen in Fig. 3 that when the number of suppressed pairs increases the rate of reduction in PAPR decreases.

The following table shows the effect of the number of suppressed pairs of maximum and minimum on system performance. It can be seen, that even if we process more than one pair of maximum and minimum, the required SNR for the same performance in the system does not change and the small difference between the amounts in the table are due to randomness of data in the experiment.

Table1: Effect of the number of suppressed pairs of maximum on system performance

	SNR (dB)				
	5	8	11	14	17
Original IFFT/FFT	0.182982	0.099638	0.035624	0.004386	0.000002
1 pair	0.172918	0.100245	0.034702	0.003584	0.000008
2 pairs	0.169012	0.098975	0.035203	0.003986	0.000009
3 pairs	0.166421	0.097778	0.035567	0.004467	0.000003
4 pairs	0.164645	0.09658	0.035985	0.0048369	0.000005
SLM (U=4)	0.18298	0.099306	0.035607	0.0043873	0.000003
SLM (U=8)	0.18303	0.099347	0.035589	0.0044164	0.000002

Many PAPR reduction schemes cause spectrum side-lobes generation in signal's Power Spectrum Density (PSD). The spectrums of the original signal and preprocessed signals through the proposed method and SLM algorithm are shown in Fig. 4 in the 3rd experiment. It can be seen that at the frequency twice the bandwidth of the main lobe, there is about 43 dB attenuation in the original OFDM spectrum. This attenuation for signal processed by SLM algorithm is approximately equal to that of the original OFDM spectrum, but this is about 24 dB attenuation in the preprocessed signal by one pair. Also, it is obvious that by suppressing more than one pair, in both preprocessing algorithm and combined method, attenuation at the frequency twice the bandwidth of the main lobe decreases. In addition, in the preprocessing method the average of signal does not change.

It is observed that through the preprocessing algorithm we could reduce PAPR of OFDM signals and lower the complexity of the system compared to other methods, while the performance of the system does not change. But the extra information that must be sent to the receiver and less attenuation in the PSD of signals are the prices that we pay.

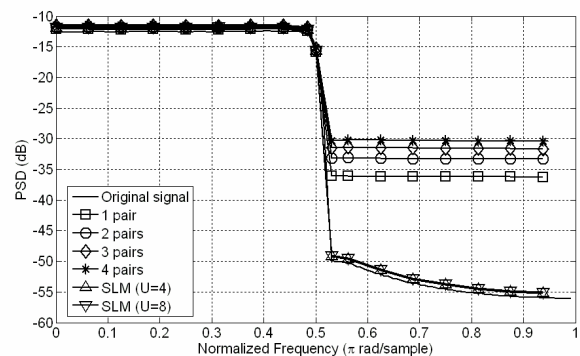

Figure 4: PSD of OFDM original signal and preprocessed signals.

B. Comparison of the Proposed and SLM methods

In this section a comparative study in terms of complexity issues in the SLM algorithm and the presented algorithm is carried out. Fig. 5 shows the architecture of the proposed method at the transmitter side. Also SLM architecture by using 4 streams to reduce the PAPR of OFDM systems is shown in Fig. 6. The input signal to both of these diagrams is the frequency domain signal and the output is the time domain signal which is transmitted.



Figure 5: The proposed method architecture.

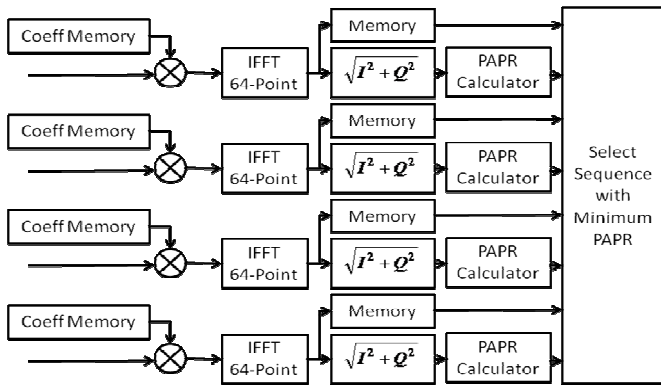

Figure 6: SLM transmitter architecture.

Assuming that both of the proposed method and SLM algorithm work in the same frequency, we can get results of the complexity comparison as in table 2. Here Comparison is done in terms of number of required blocks such as IFFT, Magnitude Calculator, PAPR Calculator, Post-Processing Blocks and amount of memory needed.

Table 2: Complexity comparison of SLM and the proposed method.

	SLM	The Proposed method
IFFT	4	1
Coeff Memory	4	0
Memory	4	1
Magnitude Calculator	4	1
PAPR Calculator	4	0
Post Processing	0	1

As in both algorithms frequency is assumed the same, SLM implementation is costly. By taking into account the FPGA implementation of SLM algorithm, it will be observed that FPGA resources are occupied at least four times of the resources used in implementing our proposed method. Also, in SLM algorithm, in order to send the sequence with the lowest PAPR there is a need to calculate PAPR of each sequence. Implementing such module requires a Dividing module which really consumes lots of resources. Also, the amount of Block RAM that SLM algorithm consumes is more than what is needed in the proposed method. It is considerable that the complexity of our proposed method is the same as original OFDM systems, but in SLM, transmitter is more complex.

Results of the previous subsection show that, SLM with 4 multiplying sequences and the proposed method with one peak suppression have the same performance in terms of system's BER. But the SLM method performs a little better in PAPR reduction. Side information for the SLM method is 2 bits for every OFDM symbol but the proposed method requires 12 bits to indicate the position of maximum and minimum. However the SLM method imposes large complexity to the transmitter.

V. CONCLUSION

In this paper a new PAPR reduction method was presented, which makes use of modified FFT/IFFT matrices. It was shown by computer simulations that the modification in FFT/IFFT matrices doesn't degrade the system's performance in terms of required SNR to achieve a specified BER, while reducing the PAPR. Furthermore it was shown that there is a generic mathematical formulation for the changes required in the FFT matrix for a given modified IFFT matrix which is another advantage of the method presented. Also the advantages and disadvantages of the proposed method in comparison with SLM were studied.

REFERENCES

- [1] Y. Wu, and W.Y. Zou, "Orthogonal frequency division multiplexing: a multi-carrier modulation scheme," *IEEE Trans. on Consumer Electronics*, Vol. 41, No. 3, pp. 392-399, Aug. 1995.
- [2] A. Conti, D. Dardari, and V. Tralli, "On the performance of CDMA systems with nonlinear amplifier and AWGN," *Proc. of 6th IEEE International Symp. on Spread Spectrum Techniques and Applications*, vol. 1, New Jersey, USA, pp. 197-202., Sep. 2000.
- [3] X. Li, L.J. Cimini, "Effects of clipping and filtering on the performance of OFDM," *IEEE Com. Letters*, Vol. 2, No. 5, pp. 131-133, May 1998.
- [4] J. Armstrong, "Peak-to-average power reduction for OFDM by repeated clipping and frequency domain filtering," *Electronics Letters*, Vol. 38, No. 5, pp. 246-247, Feb. 2002.
- [5] X. Wang, T.T. Tjhung, and C.S. Ng, "Reduction of peak-to-average power ratio of OFDM system using a companding technique," *IEEE Trans. on Broadcastsing*, Vol. 45, No. 3, pp. 303-307, Sep. 1999.
- [6] T. Jiang, and G. Zhu, "Nonlinear companding transform for reducing peak-to-average power ratio of OFDM signals," *IEEE Trans. on Broadcasting*, Vol. 50, No. 3, pp. 342-346, Sep. 2004.
- [7] A. E. Jones, T. A. Wilkinson, and S. Barton, "Block coding scheme for reduction of peak to mean envelope power ratio of multicarrier transmission schemes," *IEE Electronics Letters*, vol. 30, pp. 2098-2099, Dec. 1994.
- [8] Abouda, A. A., "PAPR reduction of OFDM signal using turbo coding and selective mapping," *Proc. of the 6th Nordic Signal Processing Symposium*, pp. 248-251, June 2004.
- [9] L.J. Cimini, Jr., and N.R. Sollenberger, "Peak-to-average power ratio reduction of an OFDM signal using partial transmit sequences," *IEEE Communication Letters*, Vol. 4, No. 3, pp. 86-88, Mar. 2000.
- [10] R. W. Bami, R. F. H. Fischer, and J. B. Hber, "Reducing the peak-to-average power ratio of multicarrier modulation by selected mapping," *IEE Electron. Lett.*, vol. 32, pp. 2056-2057, Oct. 1996.
- [11] Tellado, J., *Multicarrier Modulation with Low PAR: Applications to DSL and Wireless*. Kluwer Academic Publishers, 2000.
- [12] N. Petersson, A. Johansson, P. Odling, and P. O. Borjesson, "Analysis of tone selection for PAR reduction," *Proc. International Conference on Information, Communications & Signal Processing*, Oct. 2001.
- [13] B. S. Krongold and D. L. Jones, "A study of active constellation extension for PAR reduction in OFDM," *Proc. International OFDM Workshop*, Germany, pp. 107-111, Sept. 2002.
- [14] T. Jiang, Y. Yang, and Y-H. Song, "Exponential Companding Technique for PAPR Reduction in OFDM Systems", *IEEE Transactions on Broadcasting*, vol. 51, no. 2, pp. 244-248, June 2005.