

Single-Carrier Frequency Domain Equalization

A focus
on wireless
applications

Orthogonal frequency division multiplexing (OFDM) has been recently adopted by major manufacturers and by standardization bodies for a wide range of wireless and wireline applications ranging from digital video/audio broadcasting to power-line communications. The major virtues of OFDM are 1) its resilience to multipath propagation providing a viable low-complexity and optimal (in the maximum likelihood sense) solution for intersymbol interference (ISI) mitigation, 2) the possibility of achieving channel capacity if the transmitted signal is adapted to the state of the communication channel (i.e., if energy and bit-loading procedures are adopted), and 3) the availability of strategies for frequency diversity scheduling in multiuser communication systems. Although OFDM has become the physical layer of choice for broadband communications standards, it suffers from several drawbacks including a large peak-to-average power ratio (PAPR), intolerance to amplifier nonlinearities, and high sensitivity to carrier frequency offsets (CFOs) [6]. An alternative promising approach to ISI mitigation is the use of

Digital Object Identifier 10.1109/MSP.2008.926657



single-carrier (SC) modulation combined with frequency-domain equalization (FDE). On the one hand, the complexity and performance of SC-FDE systems is comparable to that of

[TABLE 1] TABLE OF ACRONYMS.

A/D	ANALOG TO DIGITAL
ADSL	ASYMMETRIC DIGITAL SUBSCRIBER LINE
CDMA	CODE DIVISION MULTIPLE ACCESS
CFO	CARRIER FREQUENCY OFFSET
CIR	CHANNEL IMPULSE RESPONSE
CMA	CONSTANT MODULUS ALGORITHM
CP	CYCLIC PREFIX
CPM	CONTINUOUS PHASE MODULATION
CSI	CHANNEL STATE INFORMATION
D/A	DIGITAL TO ANALOG
DAB	DIGITAL AUDIO BROADCASTING
DQE	DECISION FEEDBACK EQUALIZER
DFT	DISCRETE FOURIER TRANSFORM
DMT	DISCRETE MULTI-TONE
DVB	DIGITAL VIDEO BROADCASTING
FD	FREQUENCY DOMAIN
FDD	FREQUENCY DOMAIN DUPLEXING
FDE	FREQUENCY DOMAIN EQUALIZATION
FDM	FREQUENCY DOMAIN MULTIPLEXED
FDMA	FREQUENCY DIVISION MULTIPLE ACCESS
FDSPT	FREQUENCY DOMAIN SUPERIMPOSED PILOT TECHNIQUE
FET	FREQUENCY EXPANDING TECHNIQUE
FFT	FAST FOURIER TRANSFORM
HPA	HIGH-POWER AMPLIFIER
IB	ITERATIVE BLOCK
IBI	INTERBLOCK INTERFERENCE
IC	INTERFERENCE CANCELLER
ICI	INTERCARRIER INTERFERENCE
IDFT	INVERSE DISCRETE FOURIER TRANSFORM
IFFT	INVERSE FAST FOURIER TRANSFORM
ISI	INTERSYMBOL INTERFERENCE
LE	LINEAR EQUALIZER
LM	LINER MODULATION
LMS	LEAST MEAN SQUARE
LST	LAYERED SPACE-TIME
MC	MULTI-CARRIER
MIMO	MULTIPLE-INPUT MULTIPLE-OUTPUT
MISO	MULTIPLE-INPUT SINGLE-OUTPUT
ML	MAXIMUM LIKELIHOOD
MLSE	MAXIMUM LIKELIHOOD SEQUENCE ESTIMATOR
MMSE	MINIMUM MEAN SQUARE ERROR
MSE	MEAN SQUARE ERROR
MUD	MULTI-USER DETECTOR
MUI	MULTI-USER INTERFERENCE
OAS	OVERLAP-AND-SAVE
OFDM	ORTHOGONAL FREQUENCY DIVISION MULTIPLEXING
PAPR	PEAK TO AVERAGE POWER RATIO
PLC	POWER-LINE COMMUNICATIONS
P/S	PARALLEL-TO-SERIAL
QO	QUASI-ORTHOGONAL
QOS	QUALITY OF SERVICE
R	ROTATED
RLS	RECURSIVE LEAST SQUARE
SC	SINGLE CARRIER
SDARS	SATELLITE DIGITAL AUDIO RADIO SERVICE
SDMA	SPACE DIVISION MULTIPLE ACCESS
SFBC	SPACE-FREQUENCY BLOCK CODE
SIMO	SINGLE-INPUT MULTIPLE-OUTPUT
SISO	SINGLE-INPUT SINGLE-OUTPUT
SNR	SIGNAL-TO-NOISE RATIO
S/P	SERIAL-TO-PARALLEL
ST	SPACE-TIME
STBC	SPACE-TIME BLOCK CODE
STC	SPACE-TIME CODE
SUD	SINGLE-USER DETECTOR
TD	TIME DOMAIN
TDD	TIME DOMAIN DUPLEXING
TDE	TIME DOMAIN EQUALIZATION / TIME DOMAIN EQUALIZER
TDM	TIME DOMAIN MULTIPLEXED
TDMA	TIME DIVISION MULTIPLE ACCESS
UW	UNIQUE WORD
UWB	ULTRA-WIDE BAND
WLAN	WIRELESS LOCAL AREA NETWORK

OFDM while avoiding the above mentioned drawbacks associated with multicarrier (MC) implementation. On the other hand, FDE does not represent an optimal solution to signal detection over ISI channels and SC systems cannot certainly offer the same flexibility as OFDM in the management of bandwidth and energy resources, both in single user and in multiuser communications. All these considerations have made the choice between SC-FDE and OFDM a strongly debated issue in academic and industrial circles. For this reason, we believe that SC-FDE techniques deserve a deeper analysis in view of the significant attention given to MC techniques. The first MC scheme was proposed in 1966 [1], whereas the first approach to SC-FDE in digital communication systems dates back to 1973 [2]. Despite the small time separation between their introductions, many efforts have been devoted by the scientific community to the study of MC solutions, but little attention has been paid to SC-FDE for many years. In the last decade, there has been a renewed interest in this area. The theoretical and practical gap between the two solutions is tightening, but the technical literature on MC communication is by far larger than that on SC-FDE. In this article, we intend to provide an overview of the principles of SC-FDE with a particular focus on wireless applications and to present an up-to-date review including the latest and most relevant research results in the SC-FDE area. Our article is tutorial in nature and, therefore, our emphasis is not on detailed mathematical derivations but rather on describing the salient features of SC-FDE techniques and comparing it to its MC counterpart.

Complete lists of all the acronyms and mathematical symbols employed throughout the article are provided in Table 1 and Table 2, respectively.

ISI MITIGATION: TIME DOMAIN VERSUS FREQUENCY DOMAIN

The increasing demand for wireless multimedia and interactive Internet services is fueling intensive research efforts on high-speed data transmission. A major design challenge for high-speed broadband applications is the time-dispersive nature of the terrestrial radio channel. The effects of multipath propagation can be analyzed in the time domain (TD) or in the frequency domain (FD). In the TD, we note that when the time spread introduced by the channel is larger than one symbol period, the interference among consecutive transmitted symbols, known as ISI, distorts the received signal. In the FD, if the communication bandwidth is larger than the so-called coherence bandwidth [3] of the channel, then distinct frequency components of the transmitted signal will undergo different attenuations, resulting in a distortion.

Targeting data rates of tens of megabits per second over a wireless channel with a typical delay spread in the microseconds results in ISI spanning tens, or even hundreds, of symbols. High-speed broadband digital communication systems should be, therefore, designed to handle such severe ISI.

A well-known approach to mitigate ISI in SC digital communication systems is the compensation for channel distortions via channel equalization in the TD at the receive side.

Various time-domain equalizers (TDEs) such as maximum likelihood sequence estimators (MLSEs), linear equalizers (LEs) and decision feedback equalizers (DFEs) have been extensively studied in the past (e.g., see [3] and references therein). Historically, TDEs were developed for ISI mitigation in narrowband wireline channels and adopted in international CCITT standards for dial-up modems. TDEs can be also employed, in principle, in broadband wireless communications; however, the number of operations per signaling interval grows linearly with the ISI span, or, equivalently, with the data rates.

A viable approach to mitigate time dispersion effects is MC transmission. A well-known representative of this class of digital signalling techniques is generally referred to by discrete multi-tone (DMT) in wireline systems, while the wireless research community prefers the term OFDM. Although a different terminology is coined due to rather independent developments of the two technologies, the main feature of MC systems is their ability to convert the operating wideband channel characterized by frequency selectivity into a large number of parallel narrowband subcarriers. In fact, in MC systems, the high-rate data stream is demultiplexed and transmitted over a number of frequency subcarriers, whose channel distortion can be easily compensated for (i.e., equalized) at the receiver on a subcarrier-by-subcarrier basis.

The subcarriers are further designed to have the minimum frequency separation required to maintain orthogonality of their corresponding TD waveforms, yet the signal spectra corresponding to the different subcarriers overlap in frequency. Hence, the available transmission bandwidth is exploited very efficiently. MC techniques also enjoy the flexibility to assign variable constellation sizes and transmission powers [and hence multiple quality of service (QoS)] to their frequency subchannels in addition to the ease by which certain frequency bands can be turned off.

Although the main principles and some benefits offered by MC modulation have been established over 40 years ago (the first rigorous approach to MC system design was proposed by Chang in 1966 [1]), they have become very popular only recently with the availability of low-cost digital signal processors, since fast Fourier transform (FFT) operations need to be implemented for both modulation and demodulation. In particular, followed by intensive research efforts in academic and industrial circles mainly within the last two decades, coded OFDM has been adopted by standardization bodies and major manufacturers for a wide range of applications. Examples include digital video broadcasting (DVB), digital audio broadcasting (DAB), asymmetric digital subscriber line (ADSL), wireless local area networks such as IEEE 802.11a/b/g/n, HIPERLAN/2, wireless metropolitan area networks such as IEEE 802.16d/e, satellite digital audio radio services (SDARS) such as Sirius Satellite Radio and XM Radio, terrestrial digital audio/video broadcast (DAB/DVB-T/DVB-H) and power-line communications (PLC). OFDM is also a strong candidate for wireless personal area networks using ultra wideband technology as in IEEE 802.15.3 and for regional area networks using cognitive radio technology as in IEEE 802.22. Moreover, OFDM has been considered for various applications involved in the third genera-

tion partnership project (3GPP) long-term evolution (LTE) and in 3GPP2 revolution.

Despite its success, OFDM suffers from well-known drawbacks such as a large peak to average power ratio (PAPR), intolerance to amplifier nonlinearities, and high sensitivity to carrier frequency offsets.

An alternative low-complexity approach to ISI mitigation is the use of frequency-domain equalizers (FDEs) in SC communications. Systems employing FD equalization are closely related to OFDM systems. In fact, in both cases digital transmission is carried out blockwise, and relies on FFT/inverse FFT (IFFT) operations. Therefore, SC systems employing FDEs enjoy a similar complexity advantage as OFDM systems without the stringent requirements of highly accurate frequency synchronization (a task that is usually much simpler in SC than in OFDM systems) and linear power amplification as in OFDM. It is also worth noting that FDEs usually require a substantially lower computational complexity than their TD counterparts. In addition, recent results (see the section "Performance Comparisons Between OFDM and SC-FDE") indicate that SC systems with FD equalization can exhibit similar or better performance than coded OFDM systems in some scenarios [4].

A BRIEF HISTORY OF FDE

FD equalization was first investigated by Walzman and Schwartz [2] in 1973; they showed that adaptive channel equalization in the FD leads to a lower computational complexity and offers better convergence properties compared to its TD counterpart. It is

TABLE 2] TABLE OF MATHEMATICAL SYMBOLS.

\mathbf{A}_M	DISCRETE FOURIER TRANSFORM OF THE TRANSMITTED SYMBOLS BLOCK
\mathbf{a}_M	TRANSMITTED SYMBOLS BLOCK
a_n	n TH DATA SYMBOL
B	NUMBER OF FEEDBACK TAPS
B_F	BANDWIDTH OF THE LOW-PASS BASEBAND FILTER
C	CONSTELLATION SIZE
d_i	(REAL) AMPLITUDE OF THE i TH RAY
F_d	DOPPLER FREQUENCY
f_k	k TH TAP GAIN OF THE FEEDBACK FILTER
$gT(t)$	IMPULSE RESPONSE OF THE TRANSMIT FILTER
$h(t, \tau)$	TIME-VARIANT CHANNEL IMPULSE RESPONSE
I	OVERSAMPLING FACTOR
K_B	TEMPORAL SUPPORT OF THE FEEDBACK FILTER (MEASURED IN SYMBOL INTERVALS)
L	CHANNEL TIME DISPERSION (MEASURED IN SYMBOL INTERVALS)
M	DATA BLOCK LENGTH
M_{CP}	CYCLIC PREFIX LENGTH
M_T	OVERALL BLOCK LENGTH
N	NUMBER OF RECEIVE ANTENNAS
N_L	NUMBER OF DISTINCT RAYS IN THE MULTIPATH CHANNEL
P	NUMBER OF TRANSMIT ANTENNAS
\mathbf{P}_M	DISCRETE FOURIER TRANSFORM OF THE OVERALL CHANNEL IMPULSE RESPONSE VECTOR
\mathbf{p}_M	OVERALL CHANNEL IMPULSE RESPONSE VECTOR
p_n	n TH SAMPLE OF THE OVERALL CHANNEL IMPULSE RESPONSE
$\rho(t)$	OVERALL CHANNEL IMPULSE RESPONSE
Q	TRAINING SEQUENCE LENGTH
\mathbf{R}	RECEIVED VECTOR
$s_{LM}(t)$	LINEARLY MODULATED TRANSMITTED SIGNAL
T_s	SYMBOL PERIOD
\mathbf{V}_M	NOISE VECTOR
W_i	i TH TAP GAIN OF THE FEEDFORWARD FILTER
φ_i	PHASE OF THE i TH RAY
τ_i	DELAY OF THE i TH RAY

interesting to note that adaptive FDE filters can be categorized under the framework of multirate adaptive filtering since signal processing may be performed at a lower sampling rate than the incoming data. For this reason, over the years FDE has attracted attention within the signal processing community as a particular implementation of this type of filtering, as discussed in detail in [5]. However, it was not until the publication of a paper by Sari et al. [6] in 1995 that the communications research community realized the considerable potential of FDE. In fact, in [6], the striking similarities between the implementation of an OFDM system and that of an SC system with a FDE was pointed out and FD equalization was proposed as a low-complexity solution to digital terrestrial broadcasting which is characterized by a highly-time-dispersive channel. This has renewed interest in FD equalization as a strong competitor to OFDM and demonstrated the potential of FDE in high-speed broadband wireless access [4].

FDE is currently enjoying a growing popularity as evidenced by the large number of publications in the last few years (e.g., see [4] and [7]–[13]). Specific topics in recent research on FD equalization concern the joint exploitation of the spatial and frequency diversities, the design of nonlinear equalization techniques and the use of FDEs with nonlinear modulation formats. In particular, interest in the first topic is mainly due to the recent success of multiple-input, multiple-output (MIMO) communication techniques. The integration of FDEs into various MIMO systems has been investigated by several authors [7], [9], [11], [14]. We also note that initial research in FDEs has mainly taken into consideration linear equalization strategies and that the promising combination of FDEs with nonlinear equalization methods (such as decision feedback equalization and turbo equalization) have been recently proposed in [10]. Leveraging the potentials of nonlinear modulation schemes [such as continuous phase modulation, (CPM)] in FD equalization schemes has been investigated in [12] and [15]. Additional active research areas include the use of FDE in code division multiple access

(CDMA) systems, ultra-wideband (UWB) networks, and relay-assisted cooperative communication [13].

FDE BASICS

This section compares the structure of an OFDM system with that of an SC system using digital linear modulation (LM) and performing FD channel equalization. In both cases, we focus on a single-input, single-output (SISO) scenario and provide more details on the communication channel model and, for the SC case, on the generation of the transmitted signal and the front-end processing/sampling of the received signal.

SC AND OFDM SYSTEM MODELS

The block diagram of an SC wireless communication system employing FD equalization is depicted in Figure 1. Each group of consecutive $\log_2 C$ information bits is mapped into a complex symbol belonging to a C -ary complex constellation. Serial-to-parallel (S/P) conversion produces data blocks, each consisting of M symbols. Then, each block is cyclically extended, inserting at its beginning a repetition of its last M_{cp} symbols, i.e., a cyclic prefix (CP), transmitted during the so-called guard interval. This introduces the elegant mathematical property of periodicity over a limited observation interval in the transmitted signal, at the price of a bandwidth/energy loss due to the presence of data redundancy. The sequence of cyclically extended blocks undergoes parallel-to-serial (P/S) conversion, so that one complex symbol is available every T_s s, with T_s being the so-called channel symbol interval for digital transmission. This requires the usual operations of digital-to-analog (D/A) conversion, frequency up-conversion, and filtering implemented in any SC modulator. The resulting radio frequency signal is transmitted over a wireless channel, characterized by a time dispersion not exceeding L channel symbol intervals (this includes the contributions of transmit and receive filtering also). The signal at the output of the wireless

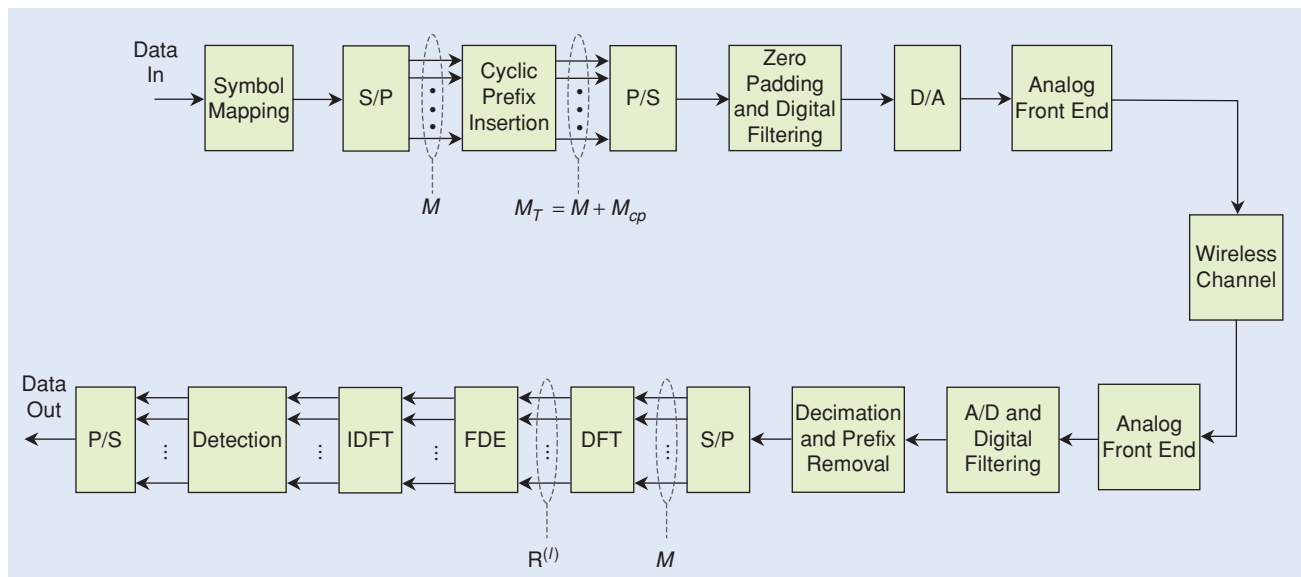

[FIG1] Block diagram of an SC digital communication system employing an FDE.

channel undergoes frequency down-conversion, filtering, and analog-to-digital (A/D) conversion, producing a sequence of noisy samples that are grouped into equal-length blocks, each associated with a transmitted data block. For each noisy data block, the CP samples are discarded and the resulting block is sent to an FFT block converting it to the FD. This is followed by an FDE compensating for channel distortion and by an IFFT block bringing the noisy signal vector back to the TD. Finally, data decisions are made on a block-by-block basis and sent to the data link layer after S/P conversion.

The block diagram of an OFDM system is illustrated in Figure 2. After symbol mapping and P/S conversion, blocks of M complex information symbols belonging to a C -ary complex constellation feed an M th order inverse discrete Fourier transform (IDFT) block, implemented as an IFFT processor. Each block at the IDFT output, after P/S conversion, is cyclically extended, adding a prefix that consists of its last M_{cp} symbols. The resulting sequence undergoes A/D conversion, frequency conversion, and filtering like in the SC system. It can be shown that, in this case, the transmitted signal associated with each data block consists of a superposition of oscillations over a limited time interval, each associated with a distinct information symbol and a specific subcarrier frequency. Moreover, over that interval, the family of complex oscillations forms a set of orthogonal signals and this property plays a fundamental role, since it greatly simplifies the task of separating their contributions in the detection process. Note that the generation of multiple waveforms is not accomplished via a bank of oscillators but by exploiting IFFT processing in the baseband section of the OFDM modulator.

If the communication channel is linear and time invariant during the transmission of each data block, its response to the superposition of complex oscillations is a signal of the same type. Each oscillation, however, is affected by a change in both its amplitude and phase (depending on the channel response to the oscillation frequency) that does not affect the orthogonality

property in the received signal. For this reason, after the usual conversion and sampling operations already described for the SC system, demodulation can be accomplished via an FFT operation, separating the contributions associated with the different subcarriers. Then, after compensating for the phase rotations and the amplitude variations in the various subchannels, data decisions can be made, for a given data block, on a subcarrier-by-subcarrier basis.

Let us now analyze the similarities and the differences between the two systems described above. First of all, we note the following:

- In both cases, one FFT and one IFFT block are employed in the system, even though in different places and for different reasons. In fact, in the OFDM system, Fourier transforms are used for modulation and demodulation, whereas in the SC system they are all incorporated in the digital receiver for converting TD signals to the FD and back, so that compensation for channel distortions can be accomplished in the FD.
- Despite the above-mentioned similarities, the different use of FFT processing leads to very different detection processes. In fact, in OFDM systems, the optimal detection strategy requires only one complex multiplication per subcarrier to compensate for the channel distortion, whereas for SC systems an equalizer followed by a detector represents a suboptimal approach to data estimation. Moreover, FD equalization in the SC system can be far more complicated even though it is characterized by an appreciably lower complexity per channel symbol with respect to its TD counterpart.
- Both systems usually employ a CP to eliminate interblock interference (IBI) so that each data block can be processed independently and the linear convolution associated with channel filtering is turned to a circular convolution, provided that the duration of the prefix is longer than that of the channel delay spread. This dramatically simplifies equalization algorithms, as explained below.

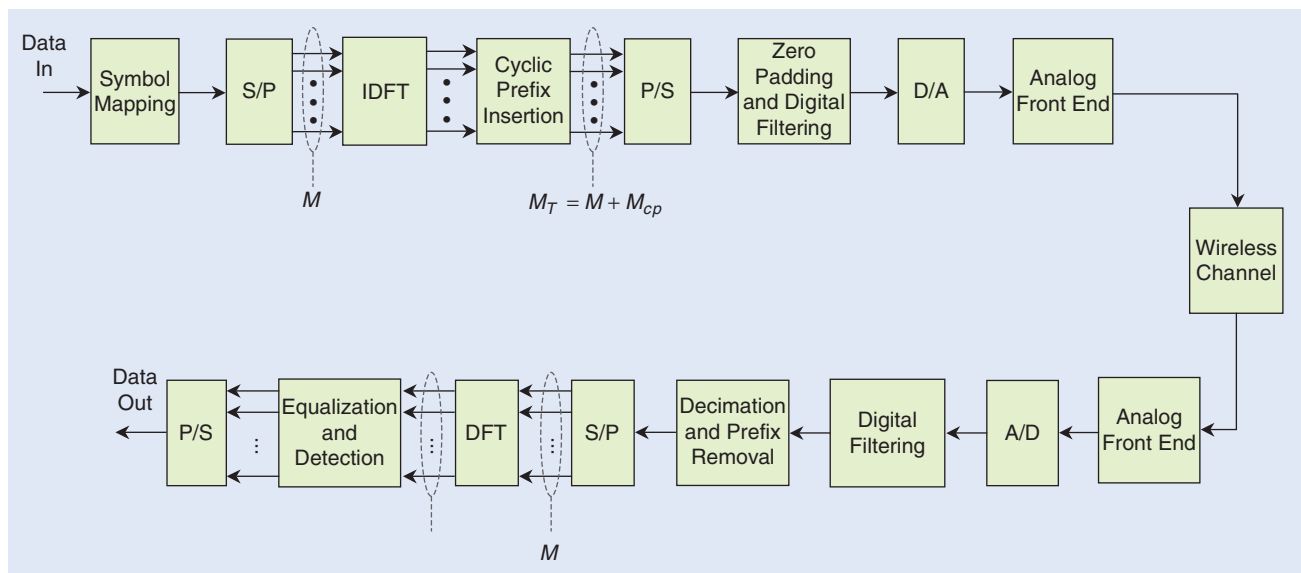

[FIG2] Block diagram of an OFDM communication system.

- Unlike SC systems, OFDM systems suffer from impairments related to the large dynamic range of the transmitted signal and to frequency nulls in the channel frequency response and from sensitivity to CFO in demodulation.

Concerning the last point, we note that since the OFDM signal is the sum of multiple sinusoids modulated by independent information symbols, its envelope is characterized by a wide dynamic range when the FFT order is large, and this increases dramatically the linearity requirements of the analog front-end. It is worth noting, however, that the advantage of SC systems in terms of PAPR with respect to OFDM systems reduces as the signal constellation size increases.

Frequency synchronization represents a critical task for the receiver because a residual frequency offset in the demodulation process produces interference between adjacent subcarriers, known as intercarrier interference (ICI). Finally, the last problem is related to the fact that data decisions are taken in the FD, so that if the channel frequency response exhibits a null close to the frequency of a subcarrier, the associated information is lost. This means that an uncoded CP-based OFDM system is unable to extract multipath diversity, so that its error rate performance is dominated by its subcarriers with the lowest signal-to-noise ratio (SNR). In practical applications, this diversity loss can be circumvented by incorporating channel coding in conjunction with frequency-interleaving among subcarriers. Note that in SC systems, decisions on the received data are taken in the TD and the averaging effect of the IFFT operation mitigates the dominating effect of low-SNR subcarriers on overall performance.

It is worth noting that our previous discussion has focused on nonadaptive systems only to simplify understanding of the basic ideas. However, in modern communication systems employing MC or SC-FDE techniques, the concept of frequency adaptivity can be exploited. This concept relies on the fact that in the communication chain of both SC-FDE and OFDM systems, there are some points in which the signal is represented in the FD. In principle, this fact can be exploited to adapt the transmitted signal to the frequency response of the radio channel, improving a significant number of relevant features, like coverage, data rate, spectral efficiency, etc. Recent research on OFDM has led to the conclusion that time, frequency, and spatial diversities can be jointly exploited if proper adaptive techniques are exploited. In addition, it has shown that frequency-adaptive OFDM systems can offer improved performance over SC systems employing various modulation formats. This motivates, in part, the adoption of OFDM for several important standards like IEEE 802.16d/e, DVB, and the fact that OFDM represents the basis for the third generation of mobile systems represented by the standard group 3GPP LTE and 3GPP2 revolution. It also important to note, however, that in the last year's proposals for SC modulation formats have emerged, and some of them are able to fill the performance gap with frequency-adaptive OFDM systems. Actually, the most appealing proposed modulation belongs to the class of DFT-pre-coded OFDM. In this case, the user wideband data flow is divided into a number of narrowband subchannels to be transmitted

serially instead of in parallel as in OFDM. This approach yields interesting results in multiuser scenarios, where the various subcarriers related to distinct users share the time and the frequency domains; such resources are distributed among the users resorting to a DFT-based precoding technique. In practice, the precoding operation destroys the MC signal properties, yielding a hybrid signal that resembles more closely the sum of SC signals than a MC transmission. According to the resource allocation policy, different communication schemes have emerged as promising solutions for wideband radio links; the most popular are the localized frequency division multiple access (LFDMA) and the interleaved frequency division multiple access (IFDMA). The main difference between these two schemes is that the former allocates a block of contiguous subcarriers to the same user, whereas the latter assigns equally-spaced subcarriers to the same user. The SC nature of these modulation formats entails a low PAPR and a substantial robustness against a CFO with respect to OFDM; this explains why IFDMA is considered as an effective solution for the uplink in hand-held applications and, in particular, has been adopted for the uplink in the LTE project (see [53] and references therein).

Let us now illustrate some specific considerations regarding the signal and the channel models for the SC scheme with FDE depicted in Figure 1.

SIGNAL AND CHANNEL MODELS

In principle, any modulation format can be equalized in the FD, even if the algorithms and their computational complexities depend substantially on it. Most articles about FD equalization deal with linear modulation formats (e.g., see [10] and the references therein) mainly because of the simplicity in algorithm design. In this case, the baseband model $s_{LM}(t)$ of the transmitted signal can be expressed as

$$s_{LM}(t) = \sum_{l=-\infty}^{+\infty} \sum_{n=-M_{cp}}^{M-1} a_n^{(l)} g_T(t - nT_s - lM_T T_s) \quad (1)$$

where $a_n^{(l)}$ is the n th symbol of the l th data block, M is the data block length, M_{cp} is the CP length, $p(t)$ is the impulse response of the transmit filter, T_s is the channel symbol period, and $M_T \triangleq M + M_{cp}$ represents the overall block length. Equation (1) shows that the baseband model of the transmitted signal is similar to the classical model for linear modulation [3]; the only difference is the presence of a prefix. It is also worth noting that this signal model can be properly modified to include a spreading sequence, turning it into a spread spectrum signal for CDMA systems. The spectral enlargement produced by spreading can provide a substantial gain in terms of achievable diversity, however, at the price of complicated equalization due to severe frequency selectivity.

Recently, FD equalization for CPM [12], [15] has been investigated because of its favorable spectral properties [16], [17] and its constant envelope making it suitable to nonlinear amplification [12]. In this case, the insertion of a CP becomes substantially more complicated because of the need

for avoiding phase discontinuities in the transmission of consecutive data blocks. The mathematical solution to this problem goes beyond the scope of this article; a detailed analysis is provided in [12].

Whatever the modulation format is, the fundamental role of the guard interval (or prefix) is to avoid IBI, thus enabling block-by-block processing at the receiver. The length of this interval is dictated by the channel memory, and the specific structure of the prefix can be exploited in a number of ways to simplify various receiver tasks and/or improve their performance. For completeness, it is important to note that data transmitted during the guard interval can also form a training sequence. Mathematically, the insertion of a CP makes the channel matrix circulant [7]. It is well known that circulant matrices are diagonalized by the DFT matrix, i.e., if the channel matrix is left-multiplied by a proper DFT matrix and right-multiplied by the corresponding IDFT matrix, this produces a diagonal matrix. Referring to Figure 1, this means that the FDE will only have to deal with a diagonal channel matrix that requires a small computational complexity [6]. Practically speaking, the CP induces on the symbols at the beginning of each data block the same ISI caused by the last part of the data block; in other words, the linear convolution between the transmitted signal and the channel impulse response (CIR) assumes the form of a circular convolution. Hence, the DFT of the received vector (in absence of noise) is equal to the product of the DFT of the transmitted signal by the DFT of the CIR. The second option for the signal transmitted during the guard interval arises from the observation that, in a cyclically extended data block, the first M_{cp} symbols are identical to the last M_{cp} ones. Therefore, instead of transmitting a series of cyclically-extended blocks, it is possible to transmit in an alternative fashion an information block and a known sequence, still preserving the previously mentioned equivalence between linear convolution and circular convolution. The main drawback of this approach is an appreciable increase in the computational complexity at the receive side since the processed block size is increased to $M + M_{cp}$ symbols. However, CP knowledge can be exploited to enhance overall receiver performance via proper signal processing techniques.

The transmitted signal can experience appreciable distortions due to the multipath nature of the communication channel. The channel model adopted in most papers on FD equalization over SISO channels is represented by a tapped delay line, whose corresponding time-variant CIR is

$$h(t, \tau) = \sum_{i=1}^{N_L} d_i(t) \exp(j\varphi_i(t)) \delta(t - \tau_i), \quad (2)$$

where t and τ are the time and the delay variables, respectively. Moreover, N_L denotes the number of distinct echoes, and $d_i(t), \varphi_i(t)$ and τ_i are the amplitude, phase and delay characterizing the i th echo, respectively. If the CIR can be assumed constant over the duration of a block, i.e., if the channel is quasi-static [10], (2) can be simplified as

$$h(\tau) = \sum_{i=1}^{N_L} d_i \exp(j\varphi_i) \delta(t - \tau_i), \quad (3)$$

dropping the dependence on t . For a MIMO scenario with P transmit and N receive antennas, the CIR is represented by a $P \times N$ matrix, collecting the impulse responses associated with all possible input-output pairs. Thus, in this model, each entry of the MIMO channel matrix takes the form of (2).

The signal at the channel output feeds a receiver employing FD equalization. After frequency down-conversion, the baseband received signal undergoes filtering followed by sampling. As far as filtering is concerned, two distinct solutions are common. The first one consists of a filter matched to the transmitter impulse response [i.e., to $g_T(t)$, see (1)] followed by symbol-rate sampling. Note that this does not generate a set of sufficient statistics, since filtering does not take into account channel distortion, i.e., it is not matched to the overall impulse response of the transmitter and receiver. Moreover, it is interesting to note that, in this case, the received vector $\mathbf{R}^{(l)}$ at the FDE input (see Figure 1) can be expressed in matrix notation as follows:

$$\mathbf{R}^{(l)} = \mathbf{P}_M^{(l)} \mathbf{A}_M^{(l)} + \mathbf{V}_M^{(l)}, \quad (4)$$

where $\mathbf{A}_M^{(l)} \doteq \text{DFT}_M[\mathbf{a}_M^{(l)}]$, $\mathbf{a}_M^{(l)} \doteq [a_0^{(l)}, a_1^{(l)}, \dots, a_{M-1}^{(l)}]^T$ is the l th block of transmitted channel symbols, $\mathbf{P}_M^{(l)} \doteq \text{diag}(\text{DFT}_M[\mathbf{p}_M^{(l)}])$, $\mathbf{p}_M^{(l)} \doteq [p_0^{(l)}, p_1^{(l)}, \dots, p_{M-1}^{(l)}]^T$, $p_n^{(l)} \doteq p^{(l)}(nT_s)$ for $n = 0, \dots, M-1$, $p^{(l)}(t)$ is the overall CIR (having time support $[0, LT_s]$), and $\mathbf{V}_M^{(l)}$ is the noise vector affecting the detection of the l th block (it consists of independent and identically distributed Gaussian random variables, each having zero mean). Here, $\text{DFT}_M[\mathbf{X}]$ and $\text{diag}(\mathbf{X})$ denote the M -point DFT of the vector \mathbf{X} and the diagonal matrix having the elements of \mathbf{X} along its main diagonal, respectively. This result shows that, if the channel gains are ideally known and channel noise is absent, channel distortion can be perfectly compensated for by premultiplying $\mathbf{R}^{(l)}$ with the diagonal matrix $(\mathbf{P}_M^{(l)})^{-1}$ and then performing a DFT on the resulting vector. This equalization strategy, commonly known as zero-forcing strategy, can produce an enhancement of the noise level, due to small channel gains. For this reason, minimum mean square strategies are commonly used, since they equalize the channel taking into account the effect of channel noise. When evaluating the mean square error (MSE) at the equalizer output to derive the optimal FDE, information symbols are usually assumed independent and identically distributed and to take on equally likely levels. If estimates of data probabilities can be acquired at the receiver through decoding of channel codes, these can be exploited to refine the equalization process through multiple consecutive iterations; a procedure commonly known as turbo equalization.

The second option for filtering consists of using a low-pass filter having bandwidth $B_F = I/(2T_s)$ followed by a sampler operating at a frequency I times larger than the matched-filter case, i.e., at a rate I/T_s , with $I \geq 2$. In this case, a set of sufficient statistics is extracted from the received signal if the sampling rate is larger than the Nyquist rate associated with the

useful component of the received signal. This property, however, is lost, like in the matched filter case, when the samples associated with the CP of each block are discarded, since a part of the useful information is wasted. In this scenario, the model of the signal at the FDE input generalizes that in (4); analytical details can be found in [10].

Finally, we note that, irrespective of the receiver filtering and sampling approach employed, equalization should be adapted to the channel state. As illustrated in the following two sections, two distinct solutions can be adopted. On one hand, if an explicit channel estimate is unavailable, adaptive equalization strategies can be employed to recursively adjust the equalizer parameters. On the other hand, if an estimate of the channel impulse (or frequency) response is available, it can be directly used to compute the equalization parameters. In both cases, the main characteristics of FDEs depend on the multiple-access strategy to the wireless channel: in time division multiple access (TDMA) and frequency division multiple access (FDMA) systems the equalizer usually deals with ISI affecting a single user, whereas in CDMA and spatial division multiple access (SDMA) systems, the equalizer should deal with both ISI and multiuser interference (MUI). The availability of multiple antennas at the transmitter and/or at the receiver also substantially affects the performance and structure of FD equalization algorithms.

CHANNEL-ESTIMATE-BASED FDE

In this section, we discuss the FDE structure in the case of known CIR and show how to compute its optimum coefficients for both SISO and MIMO scenarios. For the MIMO case, both spatial multiplexing modes and space-time-coded modes are considered. We start with a brief discussion on channel estimation methods for both SISO and MIMO SC-FDE.

SISO CHANNEL ESTIMATION

Traditionally, the FDE coefficients in SC systems are estimated from the received time domain multiplexed (TDM) training/pilot blocks, each consisting of a sequence of Q known transmitted training symbols [18]. The length of the TDM training block is set to be at least equal to the maximum delay spread of the channel and it may be equal to or less than the data block length M . Each TDM training block is preceded by a CP. If $Q < M$, the FDE coefficients derived from training can be interpolated to the values to be used for the length- M block.

The sequence of Q transmitted training symbols is known as a unique word (UW). Consider two back-to-back UWs where the first UW acts as CP that absorbs ISI from the previous data block. The second and subsequent UWs are used for channel estimation. The overhead due to the UW is $2Q/(2Q + M)$.

Channel estimation with TDM training/pilots in SC systems has the advantage of having a constant envelope, requiring a low power backoff for the amplifier. However, it requires an extra time slot for the UW that reduces the bandwidth efficiency. FDM pilots which have been typically used for channel estimation in OFDM systems can also be applied to SC systems [19]. Instead of using UWs, this pilot-assisted channel estimation technique periodically

inserts pilot tones with equidistant spacing, reducing the overhead of UWs. Two FDM pilot schemes, called the frequency-domain-superimposed pilot technique (FDSPT) and the frequency-expanding techniques (FETs) have been proposed for SC-FDE systems [19]. The FDSPT periodically scales frequencies for superimposing of the pilot tones; hence, it preserves spectral efficiency at the expense of performance loss and induces a slightly higher PAPR than FET [19]. FET shifts a group of data frequencies for multiplexing of pilot tones at the expense of spectral efficiency. Therefore, it has a slightly lower spectral efficiency than FDSPT due to the expansion of data frequencies to multiplex the pilot tones. FET does not suffer from performance loss but has a slightly higher PAPR than that of FDSPT and is commonly used in OFDM systems.

MIMO CHANNEL ESTIMATION

For a MIMO system with P transmit and N receive antennas, we need to estimate the frequency responses between each transmit-receive antenna pair, i.e., we need to estimate NP channel frequency responses for each tone. Since we have N receive antennas, we could employ the channel estimation method proposed above for SISO systems to estimate the N channel frequency responses for a given substream, provided that the other substreams do not transmit [20], [21]. For simplicity, we can assume that the length of the TDM training block M is K times the CP length. This implies that we only need to estimate the channel frequency response for M/K uniformly spaced frequencies. Then, the overall channel frequency response can be obtained through a standard DFT-based interpolation [20].

FDE IN A SINGLE-USER SCENARIO

FDE IN SISO SYSTEMS

The conventional SC-FDE structure compensates for channel distortions through feedforward linear filtering; this requires only one complex multiplication per symbol [6]. For several years, only linear equalization was considered for comparison with OFDM systems, but recently various nonlinear techniques have been investigated. This is due to the fact that, as shown in TD equalization theory, the introduction of a feedback filter improves error performance, since ISI can be cancelled in two subsequent steps instead of a single one. It is worth noting, however, that whereas the feedforward filter always processes FD samples of the received signal, the feedback section operates in the TD, where estimates of channel symbols are available [22]. A joint design of the feedforward FD and feedback TD sections is described in [4], which illustrates the appreciable energy savings deriving from the use of a feedback section. An alternative solution to FD DFE design, based on noise prediction, has been proposed in [23]; it exhibits the same performance as the solution proposed in [4] with the advantage of a smaller computational complexity.

It is important to note that most works concerning FD equalization in the presence of a known channel rely on the assumption of a quasi-static channel, i.e., assume that channel variations are negligible during the transmission of each single

data block. If the propagation channel is selective in both the TD and the FD, i.e., it is a doubly selective channel, the FD received vector is no longer described by (4) because of ICI. To overcome this problem, [24] and [25] have proposed the use of a double filtering scheme, where a TD filter mitigates ICI, whereas the FDE compensates for ISI. An iterative approach can be adopted to ensure an acceptable computational complexity that would otherwise be huge in any joint compensation scheme.

FDE IN MIMO SYSTEMS

The severe frequency selectivity often characterizing wideband radio channels can be mitigated relying on the spatial diversity available in a MIMO communication scheme. This idea is studied in [7] and [26], where various frequency-selective subchannels are combined to produce a single subchannel with moderate frequency selectivity through joint space-time (ST) decoding and FD equalization. To achieve this goal, properly designed ST block codes (STBCs) are used. An alternative to joint ST decoding and equalization has been proposed in [9], where a layered architecture is presented and the receiver consists of multiple stages, where each stage combines a FDE with an interference canceller (IC). In each stage, the equalizer mitigates the ISI related to the MIMO frequency-selective channel, whereas the IC tries to separate the information substreams transmitted by distinct antennas. Note that the cascade connection of multiple stages ensures an iterative refinement of the detected information.

It is important to note that the use of the STBCs mentioned previously relies on the assumption that the CIR does not change appreciably over two subsequent data blocks; various wireless channels, however, are characterized by large Doppler shifts. To solve this problem, space-frequency block codes (SFBCs) have been recently investigated [27].

FDE IN A MULTIUSER SCENARIO

FDE IN MULTIUSER SISO SYSTEMS

If the transceiver is equipped with only one antenna, a CDMA technique should be adopted to suppress MUI. The historical approach to detection in the presence of a multipath channel with CDMA systems is the so-called Rake receiver which is unable to cope with ISI spanning hundreds of symbols.

In CDMA systems, receivers can be classified as multiuser detectors (MUDs) and single-user detectors (SUDs). The MUD class accomplishes joint estimation of multiple users in order to cancel MUI, while the SUD class aims at simply suppressing MUI by exploiting properties of the signal associated with the user of interest. Currently, research efforts are focusing on SUDs because of their lower complexity. In particular, the idea introduced in SFBC of correlating the information across frequency subcarriers in order to improve the robustness against fast fading has been exploited in [28], where adjacent subcarriers are differentially encoded and noncoherent detection is employed. The design principle of increasing the complexity of the transmitter to lower that of the receiver has also been applied to enable a more efficient MUI mitigation at the receiver. This is

exemplified by [29], where a preprocessing procedure for the transmitter and a post-processing procedure for the receiver have been derived in order to lump the MUI in the quadrature branch. Thus, if a real constellation is used, like in binary phase shift keying, MUI free detection can be achieved.

FDE IN MULTIUSER MIMO SYSTEMS

SDMA represents an attractive solution to increase the spectral efficiency of wireless systems. SDMA is based on the use of beamforming techniques that amplify or attenuate signals on the basis of their directions of arrival with respect to the antenna array. In particular, with signal processing algorithms, the spatial signatures related to distinct users can be exploited to distinguish signals transmitted over the same bandwidth in the same time slot. In particular, FD equalization has been applied to SDMA systems to mitigate the ISI affecting severely time-dispersive channels in [30].

ADAPTIVE FDE ALGORITHMS

The coherent SC-FDE techniques described in the section “A Brief History of FDE” require channel state information (CSI), which is typically estimated and tracked using training sequences, inserted in each transmitted block, that increase the system overhead. Reduction of this overhead requires using longer blocks, which may not be viable for channels with fast time variations and for applications with stringent delay restrictions. These observations motivate us to develop adaptive FDEs, where CSI is not explicitly estimated at the receiver.

ADAPTIVE SISO AND SIMO FDE

Adaptive FDE receivers for SISO and SIMO systems using either least mean square (LMS) or recursive least square (RLS) algorithms have been investigated in [31]. Indeed, [31] incorporates both diversity combining and adaptive algorithms into a FDE. In particular, it is shown that for a two- or four-branch adaptive FDE operating in broadband wireless link with 60 symbols of dispersion, the equalizer converges quickly to a near-optimum solution. Also, it is observed that the adaptive FDE offers a huge complexity saving compared to adaptive TDEs [31]. For N -branch diversity, the RLS algorithm [31] implementation complexity grows only with N^2 . Therefore, for receivers with only a few diversity branches, the FD RLS algorithm has practical complexity.

ADAPTIVE FDE-STBC

Adaptive receivers still require training overhead to converge to their optimum settings and, in the presence of channel variations, are updated using previous decisions to track these changes. Adaptive algorithms, such as the celebrated LMS algorithm [3], are widely used in single-antenna systems today because of low implementation complexity. However, the LMS technique has been shown to exhibit slow convergence and suffer from significant performance degradation (relative to performance achieved with the optimum settings) when applied to broadband MIMO channels due to the large number of parameters that need to be simultaneously adapted and to the wide

eigenvalue spread problems encountered on those channels. Faster convergence can be achieved by implementing a more sophisticated algorithm belonging to the RLS family. High computational complexity compared to LMS and notoriously fickle behavior when implemented in finite precision have limited the appeal of this solution. However, it has been shown in [32] that it is possible to combine RLS algorithms with the algebraic structure of a STBC and obtain fast-convergence (RLS performance at LMS complexity). In this way, the system overhead can be reduced. We start with the single-user transmission case.

SINGLE-USER FDE-STBC: JOINT ADAPTIVE EQUALIZATION AND DECODING

The block diagram of the adaptive receiver proposed in [32] is depicted in Figure 3. The received signal is transformed to the FD via FFT processing, then the received is collected into a data matrix with quaternionic structure. A 2×2 orthogonal matrix of the form $\begin{bmatrix} a & b \\ -b^* & a^* \end{bmatrix}$ is said to have a quaternionic structure. The adaptive filter output is the product of the data matrix and the filter coefficients and is transformed back to the TD via an IFFT followed by a decision device. The output of the equalizer is compared to the desired response to generate an error vector, which is used to update the equalizer coefficients according to the RLS algorithm. The equalizer operates in a training mode until it converges, then it switches to a decision-directed mode where previous decisions are used to update the equalizer coefficients for tracking. When tracking channels with fast variations, retraining blocks might be needed to prevent divergence of the adaptive algorithm.

MULTIUSER FDE-STBC: JOINT ADAPTIVE EQUALIZATION, DECODING, AND INTERFERENCE CANCELLATION

The generalization of the adaptive FDE-STBC receiver structure to the N -user scenario with N receive antennas is

described in detail in [32]. In this case, the received signals from all N receive antennas are transformed to the FD using FFT, then N distinct quaternionic data matrices are formed and passed through a bank of N adaptive FDE filters (for each receive branch) to perform joint equalization and interference cancellation and to produce the FD estimates of the N -users' transmitted data $\hat{X}_1, \dots, \hat{X}_N$. These outputs are transformed back to the TD using IFFT and decision devices are used to generate the receiver outputs. The receiver first operates in a training mode where known training data are used to generate the error vectors and update the receiver coefficients until they converge; then, it switches to a decision-directed mode where previous decisions are used to update the receiver coefficients for tracking. For decision-directed operation, the reconstructed data are transformed back to FD and compared to the corresponding receiver outputs to generate error vectors which are used to update the coefficients according to the RLS algorithm. Again, the computational complexity can be significantly reduced and matrix inversion can be avoided by exploiting the quaternionic structure of the Alamouti STBC.

BLIND FDE

As mentioned above, adaptive equalizers typically operate in two different modes. In the training mode, a known sequence is used to initialize the tap gains in the equalizer filter, whereas in the tracking mode, tap gains are adjusted to follow slow channel variations. Here the term "tap" does not refer to the communication channel but to the transversal filter of an equalizer. In general, its meaning depends on the context in which it is used. However, the overhead introduced by the transmission of periodic training sequences may become intolerable for fast-fading environments, so that the adaptive algorithm may even diverge from the optimal solution. In these cases, blind equalizers may solve the problem. The derivation of blind equalization algorithms is commonly based on the adoption of specific cost

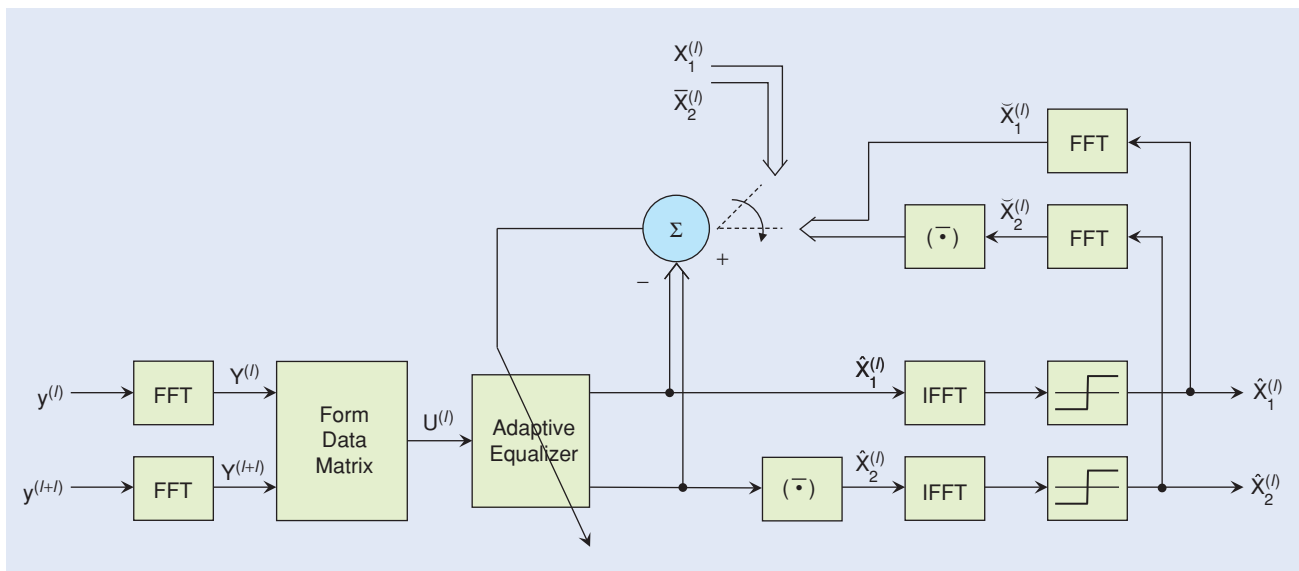

[FIG3] Proposed adaptive SC FDE-STBC block diagram for single-user scenario with two transmit and one receive antennas.

functions, which are minimized via a stochastic algorithm (e.g., the stochastic steepest descent algorithm). Unfortunately, cost functions are usually far from being smooth, and this implies that a) the convergence of blind equalizers is by far slower than that achievable with adaptive techniques and b) the steady state error is larger compared with that achievable by channel-estimate-based algorithms.

Blind equalizers may take advantage of the circulant structure characterizing the channel matrix when a CP-based signalling format is adopted. In particular, a FD constant-modulus algorithm (CMA) was derived in [33] to achieve reduced-complexity equalization in SISO systems. If the transceiver is equipped with an antenna array, FD subspace methods can be adopted to estimate channel parameters [34]. Recently, a transmitter precoding strategy has been proposed to induce particularly favorable statistical properties in the received signal to simplify the blind equalization task [33], [35].

EXTENSIONS AND RECENT RESULTS

In this section, we discuss generalization of the basic FDE structure and recent research results.

CPM

It is well known that CPM signals are characterized by a nonlinear dependence on the information symbols and may require complicated receiver schemes, even in the absence of ISI. Recently, the FD equalization principle has been successfully applied to CPM detection over frequency-selective channels. To simplify the derivation of equalization algorithms, CPM signals have been represented as the superposition of multiple linearly-modulated components, so that known equalization techniques are applied to each component. In particular, FD linear equalizers have been derived on the basis of both Gram-Schmidt orthogonalization procedures and the Laurent decomposition in [15], whereas a FD DFE based on Laurent decomposition has been proposed in [12].

FDE WITH FEEDBACK FILTER

It is well known that a DFE achieves better performance than a LE assuming no error propagation [3]. In a conventional TD DFE, symbol-by-symbol received data are filtered by a feedforward filter and the detected data are immediately exploited by a feedback filter to remove their interference effects from subsequently detected symbols.

Because of the block processing delay in FDE, this immediate decision feedback filtering action can not be implemented in the TD. A hybrid time-frequency domain DFE that avoids the above-mentioned feedback delay problem, using a FD feedforward filter and a TD

feedback filter, was introduced in [4], [18], and [22]. Distortion effects due to the sampling errors can be mitigated by oversampling the received signal at a higher rate than the symbol rate and decimating the equalized output of the feedforward filter in the TD. This transversal feedback is relatively simple since it does not require complex multiplications (for binary phase shift keying (BPSK) and quadrature phase shift keying (QPSK) constellations). Complexity is reduced by making the feedback filter sparse, corresponding to the largest CIR taps [18].

The block diagram of the hybrid time-frequency domain DFE introduced in [4] is depicted in Figure 4. The M FFT output coefficients $\{R_k^{(l)}\}$ are multiplied by M feedforward equalizer coefficients $\{W_k\}$. An FFT is applied to the feedforward filter output and the resulting sequence is passed to a TD feedback filter and ISI due to previously detected symbols is subtracted off in a symbol-by-symbol fashion. In the section “FDE with Feedback in MIMO Systems,” we show how this hybrid time-frequency domain DFE can be extended to MIMO systems.

A major challenge with the DFE approach is in mitigating error propagation. The DFE relies on delay-free hard decisions (before decoding) to cancel ISI in subsequent data symbols. The resulting error propagation limits the achievable coding gain of any coding technique. The error propagation in a hybrid time-frequency domain DFE is limited by implementing only a few feedback taps. However, if the hybrid DFE has a long feedback filter, the delay-free hard decisions are not reliable and the effects of error propagation become more pronounced. To remedy this problem, the authors in [23] have proposed to implement the feedback in a noise-predictive form [36]. The FDE with a noise-predictive feedback filter is shown in Figure 5. It consists of a FD feedforward filter and a TD noise-predictive filter. The noise predictor estimates the distortion of preceding symbols by linearly filtering the noise and residual ISI of the previously detected symbols. The feedforward filter and noise predictor are independently designed, while the feedforward and feedback filters of a hybrid time-frequency domain DFE are jointly designed. Hence, various performance and complexity tradeoffs can be obtained by only changing the noise predictor.

FDE WITH FEEDBACK IN MIMO SYSTEMS

In MIMO systems, the complexity of the optimum maximum likelihood (ML) detector increases exponentially with the

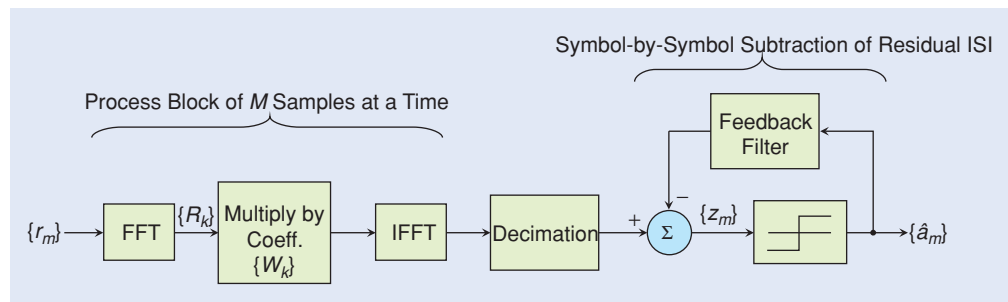

[FIG4] Hybrid DFE.

maximum channel memory and the number of transmit antennas. FDE techniques have been shown to be suitable for highly-dispersive MIMO channels [14], [37]. In this section, we extend the ideas of [18] and present new hybrid time-frequency domain receivers for highly dispersive MIMO channels.

HYBRID TIME-FREQUENCY LST RECEIVER

The hybrid time-frequency domain layered space-time (LST) receiver for detecting P streams of data symbols is shown in Figure 6. It consists of P successive multiple-input, single-output (MISO) hybrid time-frequency domain DFEs. At each stage, the best substream data block, in the minimum mean square error (MMSE) sense, is selected, detected by a MISO-DFE, transformed to the frequency domain by an FFT opera-

tion, subtracted from the received signal in the FD, and finally the residual signal is passed to the next stage for equalization and detection of the next best data block. The p th stage of the MISO-DFE, shown in Figure 7, has a FD feedforward filter with $M \cdot I$ (I is the oversampling factor) taps $\{w_{pn}^{l+kM}\}$ ($l = 0, \dots, M - 1; k = 0, \dots, I - 1$) at receive antenna n and B sparse TD feedback taps. The feedforward filter suppresses the ISI and spatial interference, and the residual ISI is cancelled by a feedback filter. For the hybrid time-frequency LST receiver, the only feedback at stage p consists of the previous data decisions of the p th data stream. The number of interfering signals is reduced by one at each stage due to interference cancellation. The simulated channel has six equal-power rays that fade independently and are uniformly spaced by the symbol rate. Each data block consists of $M = 64$ QPSK data symbols plus CP.

Each data block consists of $M = 64$ QPSK data symbols plus CP.

HYBRID TIME-FREQUENCY MIMO-DFE

The MIMO-DFE, shown in Figure 8, consists of a FD fractionally spaced feedforward filter and a TD feedback filter with a temporal span of K_B taps. It is fully connected since cross feedbacks are

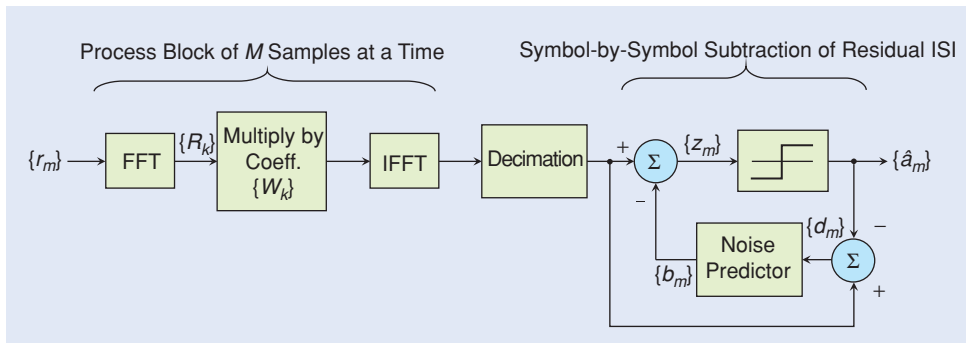

[FIG5] FDE with noise TD predictive feedback.

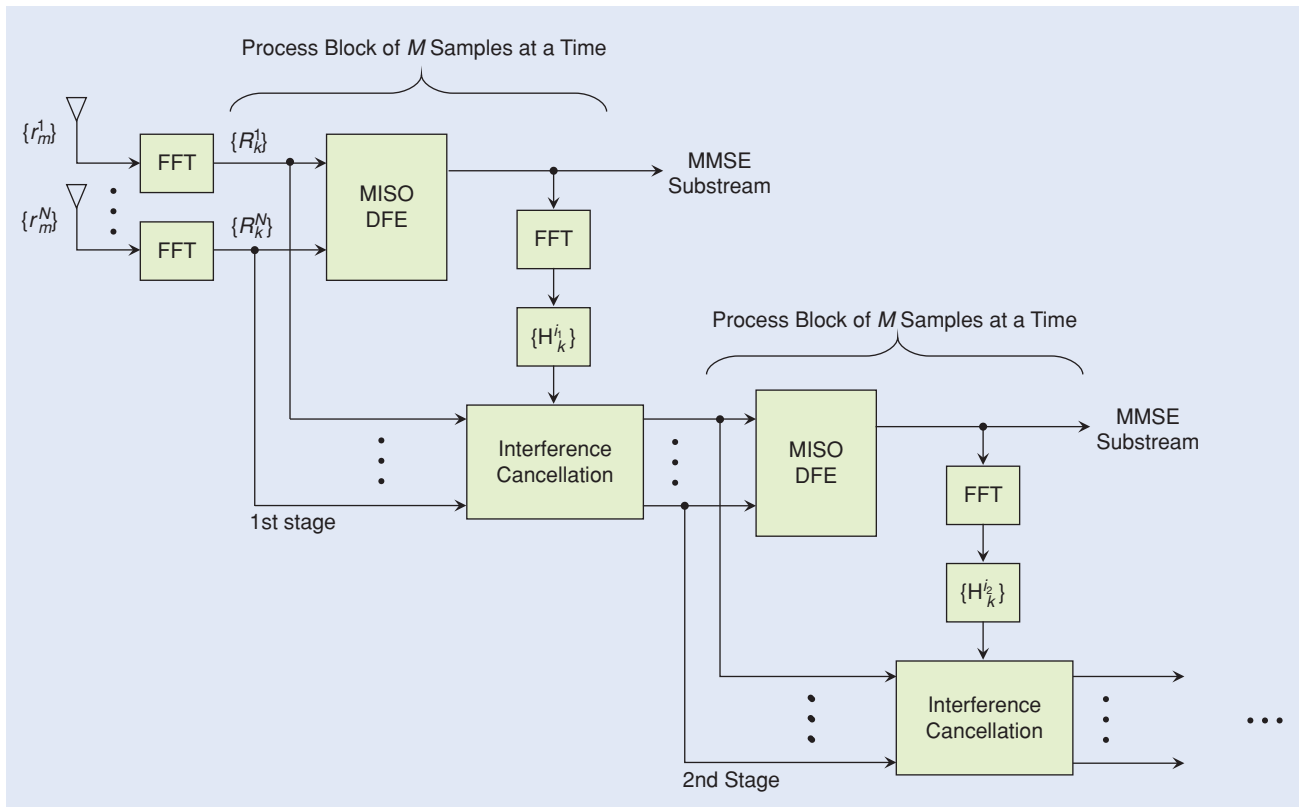

[FIG6] Hybrid time-frequency domain LST-DFE.

implemented to feed back all the past decisions from all substreams into the detection of each substream. The use of cross feedback in multiuser systems to couple the decisions from other users to the desired user was originally proposed in [39]–[41]. A hybrid MIMO-DFE has a more powerful feedback than a hybrid LST receiver but it is more sensitive to error propagation effects. The effect of different numbers of feedback taps for the MIMO-DFE is shown in Figure 9 [38]. The simulation parameters are the same as those adopted in the previous section.

In the MIMO-DFE, all substreams are detected simultaneously, each having a feedforward filter with taps $\{w_{l+kM}^{pn}\}$

($l = 0, \dots, M - 1, k = 0, \dots, I - 1$) at antenna n and a feedback filter with taps $\{f_k^p\}$ ($p = 1, \dots, P$).

ITERATIVE BLOCK MIMO-DFE

In the previous subsections, we briefly reviewed the receiver structures with feedback for MIMO channels. Although the performance of these nonlinear receivers is better than that of linear receivers, they suffer from error propagation, especially for long feedback filters. To reduce error propagation effects, a promising iterative block DFE (IB-DFE) for MIMO system employing FDE techniques was proposed in [9],

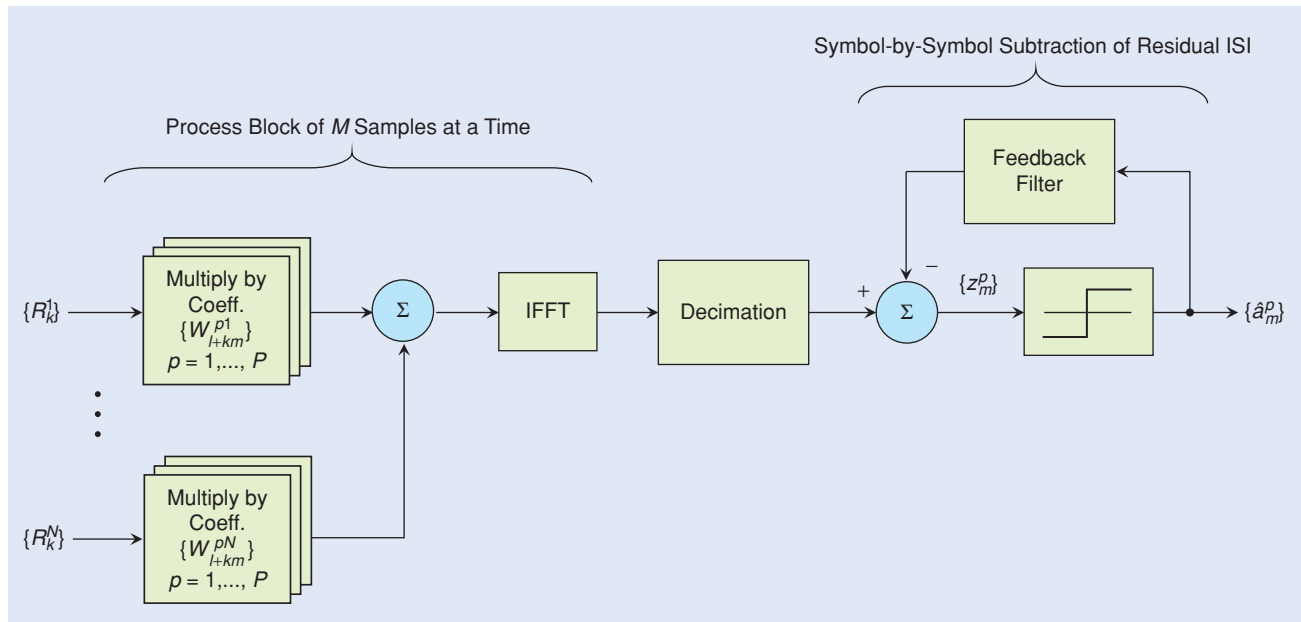

[FIG7] Block diagram of MISO-DFE.

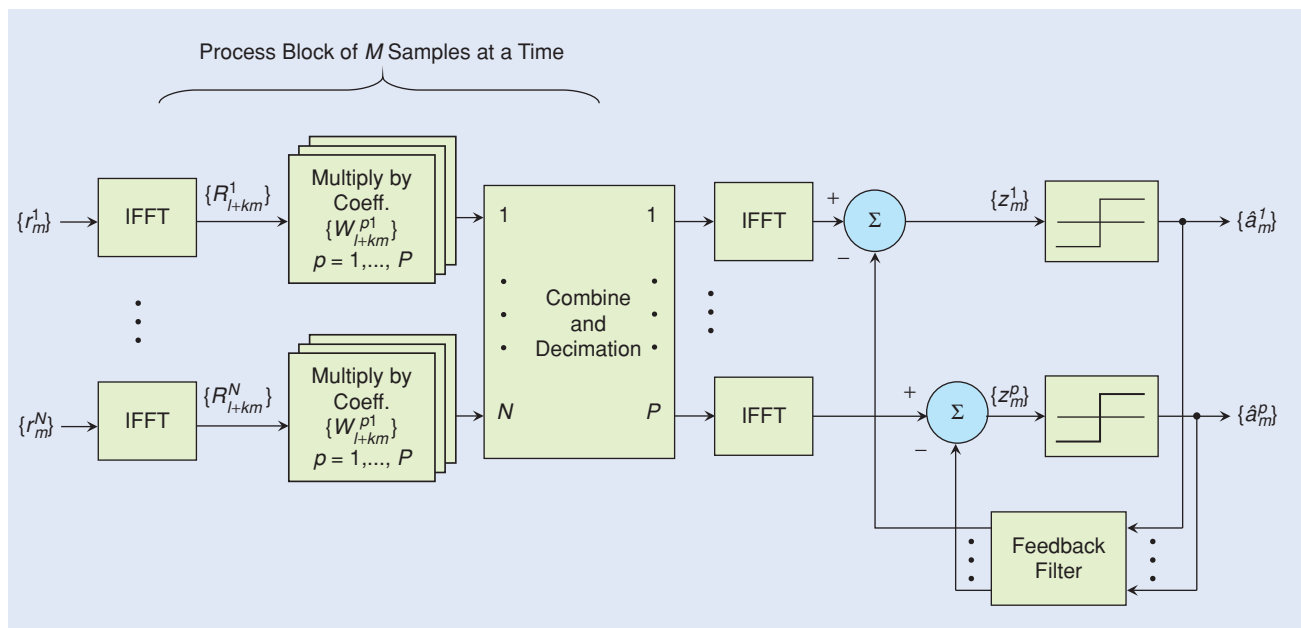

[FIG8] Block diagram of MIMO-DFE.

where both the feedforward and feedback filters are implemented in the FD. Since the feedback loop takes into account not just the hard-decisions for each block, but also the overall block reliability, error propagation is significantly reduced. Consequently, the MIMO-IB-DFE offers much better performance than the non-iterative receiver. The IB-DFE techniques can be regarded as low-complexity turbo equalization, since the feedback loop uses the equalizer output instead of the channel decoder outputs.

For a given iteration, the receiver for the detection of the p th layer has N FD feedforward filters (one for each antenna) and P FD feedback filters (one for each layer). The feedforward filters are designed to minimize both ISI and spatial interference that can not be cancelled by feedback filters, due to decision errors in the previous detections steps. After an IFFT operation, the corresponding TD outputs are passed through a decision device so as to estimate the transmitted stream. At the next iteration, these steps are repeated with a priori knowledge of the estimated streams from the previous detection steps. The proposed receiver requires N FFT operations, one for each receiver antenna, and a pair DFT/IDFT for the detection of each stream for each iteration. Interference cancellation can be performed either successively or in parallel [9].

TURBO FDE

Channel coding is a powerful tool to provide reliable communication links over fading channels. The optimal joint approach to equalization and decoding is usually unfeasible because of its formidable computational complexity; hence, these two tasks are usually carried out independently result-

ing in suboptimum performance. A more recent approach to coded-data detection over frequency-selective channels is turbo equalization, where the equalizer and the decoder exchange soft information to iteratively refine decisions on the transmitted symbols. The involved computational complexity is not substantially larger than that of the disjoint approach, whereas error performance is significantly improved. Several works on TD turbo equalization have appeared in the technical literature, but only a few consider FD turbo equalization including the pioneering work in [42] and the case of doubly-selective channels in [24]. The use of a FD-DFE equalizer was investigated in [10] for a SISO environment and in [11] for a MIMO scenario.

FDE FOR QUASI-ORTHOGONAL STBC

In [7], it was shown how an SC-FDE can be efficiently integrated with the Alamouti STBC scheme designed for two transmit antennas. This scheme is able to achieve the full diversity and rate 1 for both real and complex signal constellations. Addressing transmission rate efficiency, quasi-orthogonal STBCs (QO-STBCs) [43] were proposed to provide a partial diversity of 2 at rate 1 for four transmit antennas and can be easily generalized for 2^n ($n > 2$) transmit antennas. These codes allow a relatively low-complexity receiver implementation where the decoding complexity grows proportionally with C^2 , where C denotes the constellation size. Rotated QO-STBCs (R-QO-STBCs) [44] ensure full diversity at rate 1 while still keeping the same decoding complexity of their original counterparts. R-QO-STBCs are based on the original QO-STBCs, where half of the symbols in the original codes are chosen from a given signal constellation set while the other half is chosen from a phase-rotated version of the same constellation. Since QO-STBCs (both original and rotated versions) have been proposed for frequency-flat fading channels, it becomes a challenging design problem to apply them over frequency-selective channels. In [26], Mheidat et al. investigated the integration of FDE in QO-STBC schemes and their rotated versions. Their proposed scheme is essentially an extension of the QO-STBCs to frequency-selective channels by imposing the quasi-orthogonal structure at a block-level instead of the original symbol-level realization for the flat-fading channel case. The proposed block-level implementation allows pair-decoupling which brings significant reductions in receiver complexity. Further reductions in the complexity are also realized in [26] through the use of certain QO-STBCs which enjoy a favorable performance in medium SNR range (up to 20 dB), although their asymptotically high SNR performance is inferior. A comparative performance study of FDE-QO-STBC with TD equalization and OFDM can also be found in [26].

FDE IN RELAY NETWORKS

The revolutionary concept of space-time codes (STCs) introduced in the late 1990s has demonstrated that the deployment of multiple antennas at the transmitter allows for increase in throughput and reliability. Multiple-antenna techniques are very attractive for deployment in cellular applications at base stations

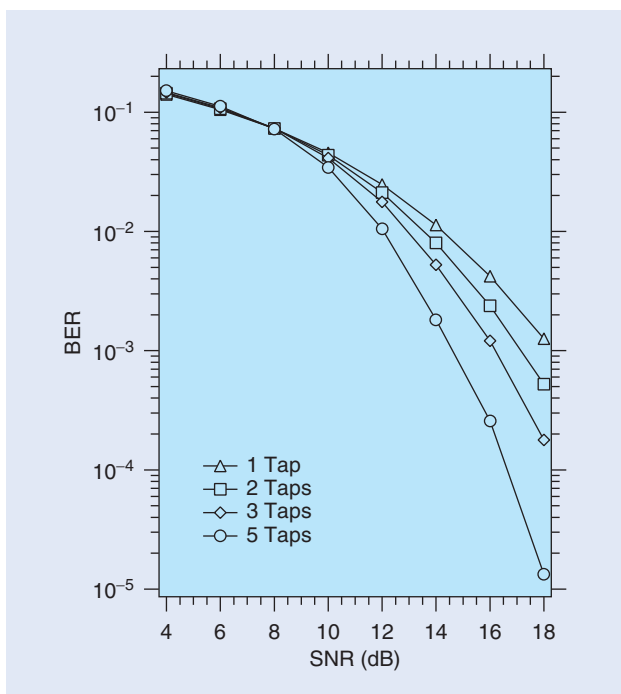

[FIG9] BER for different feedback taps for MIMO-DFE.

and have already been included in the 3G cellular wireless standards and next-generation wireless local area network (WLAN) standards (such as IEEE 802.11n). Unfortunately, the use of multiple antennas might not be practical at the mobile devices as well as in sensor networks due to size and power constraints. This limitation motivates cooperation between different nodes where a node attempts to use antennas of other nodes to relay its message. User cooperation, also known as cooperative diversity [45], [46], exploits the broadcast nature of wireless transmission and creates a virtual (distributed) antenna array through cooperating nodes to extract spatial diversity.

Conventional STCs can be used in a distributed fashion to leverage the cooperative diversity advantages. However, the implementation of distributed STCs raises several challenges since in a practical scenario the source and its relays are subject to different time delays typically larger than those encountered with colocated antenna elements. This would, in effect, convert the operating flat-fading channel into a frequency-selective channel. Frequency selectivity should also be considered for wide-band sensor network applications, such as video surveillance, that are supposed to handle huge traffic volumes of real-time video. A comprehensive investigation of TD and FD equalization techniques for relay networks has been recently reported in [13]. Specifically, [13] considers the distributed implementation of the Alamouti code within a single-relay scenario where the source-to-relay (S→R), relay-to-destination (R→D), and source-to-destination (S→D) links experience possibly different channel delay spreads. The performance analysis of distributed STBC with FDE demonstrates that a maximum diversity order of $\min(L_1, L_3) + L_2 + 2$ can be achieved, where L_1 , L_2 , and L_3 are the channel memory lengths for S→R, S→D and R→D links, respectively. This illustrates that the minimum of the multipath diversity orders experienced in S→R and R→D links becomes the performance bottleneck for the relaying path. For the case of a nonfading relaying path where line-of-sight propagation is possible in either one of these underlying links, we demonstrate that diversity orders of $L_1 + L_2 + 2$ and $L_3 + L_2 + 2$ are achievable assuming nonfading S→R and R→D links, respectively. A summary of achievable diversity orders for distributed STBC-FDE is provided in Table 3.

A similar analysis, not shown here due to space limitations, for distributed OFDM-STBC shows that uncoded OFDM is able to exploit only spatial diversity and achieves only a diversity order of two in a single-relay scenario [13]. Similar to traditional noncooperative communication, outer coding with frequency interleaving can be combined with OFDM to extract the available multipath diversity.

OVERLAP AND SAVE PROCESSING

The CP overhead in SC-FDE systems can be avoided by using well-known FD overlap-and-save (OAS) processing methods. This allows the computationally-efficient FDE methods to be applied to existing SC air interfaces which do not incorporate a CP [18]. The set of $2M$ coefficients of the OAS equalizer are the DFT of the M TD coefficients which have been zero-padded to

[TABLE 3] ACHIEVABLE DIVERSITY ORDERS FOR DISTRIBUTED STBC-FDE.

S → R	R → D	S → D	ACHIEVABLE DIVERSITY ORDER
FADING	FADING	FADING	$\min(L_1, L_3) + L_2 + 2$
FADING	NO FADING	FADING	$L_1 + L_2 + 2$
NO FADING	FADING	FADING	$L_2 + L_3 + 2$

size $2M$. Thus, the performance of the OAS equalizer with $2M$ coefficients is equivalent to the corresponding M -tap TDE. In OAS processing, the received symbols are parsed in blocks of length $2M$ which are overlapped by M symbols. The length- $2M$ block is converted and equalized in the FD and then converted to the TD, where the last part of the block is discarded.

A linear FDE with CP can invert the cyclic frequency response of the channel, whereas a TDE would in general require an infinite number of taps. Thus, an OAS equalizer cannot outperform the corresponding CP equalizer. Simulation results show that, for channels with delay spreads smaller than the block length M , their performances are comparable [18]. In fact, CP and OAS equalizers both need to use an FFT size much longer (at least eight to ten times) than the delay spread of the channel to reduce the CP overhead in SC-FDE systems and to ensure that the performance of the OAS equalizer is not degraded appreciably.

Computation of the OAS equalizer coefficients from the corresponding TD equalizer coefficients is unattractive because of the latter's high computational complexity. A pragmatic method to approximate the OAS equalizer coefficients from those found for the CP-based FDE was proposed in [18].

PERFORMANCE COMPARISONS BETWEEN OFDM AND SC-FDE

In this section, we discuss various performance results comparing OFDM systems to their SC-FDE counterparts. SISO, SIMO, and MIMO systems are considered both with and without channel coding. For the sake of fairness, it is important to note that, in most of the performance comparisons between OFDM and SC-FDE systems, nonadaptive OFDM is considered. Adaptive OFDM systems (i.e., those employing bit or power loading algorithms) are certainly able to outperform their SC counterparts. However, innovative SC modulation techniques, like IFDMA or LFDMA, seem to be able to fill this performance gap. In addition, the implementation of adaptive procedures in OFDM requires an accurate knowledge of the channel state information, and this makes it challenging to adopt them in mobile communications.

UNCODED SYSTEMS

FDE and OFDM share the following basic features: both transmission schemes are block based, rely on FFT/IFFT operations, and have a guard interval inserted in the individual blocks to mitigate IBI. In an OFDM scheme, IFFT and FFT blocks are employed at the transmitter and receiver, respectively. On the other hand, FDE schemes employ both FFT and IFFT blocks at the receiver side. Therefore, in SC-FDE, decisions are made in the TD whereas in OFDM, decisions are made in the FD. The use

of an IFFT operation at the receiver spreads the noise contributions of all of the individual subcarriers, therefore, narrowband notches in the channel frequency response have only a small impact on error probability.

In Figure 10, the error rate performance of two SC systems with a FDE and two OFDM systems is considered. A frequency-selective Rayleigh fading channel with $L = 3$ taps and uniform power delay profile is assumed. FFT size is chosen as 128 and the guard interval length is equal to channel memory. It is observed that MMSE SC-FDE outperforms OFDM by 8.3 dB at bit error rate (BER) = 10^{-3} . It should be further emphasized that although the considered SC-FDE system only enjoys partial diversity, this is sufficient for outperforming uncoded OFDM, which is limited to a diversity order of one. To have further insight into ultimate limits of SC-FDE and to provide a lower bound on suboptimal LE performance, we include the ML receiver performance of SC-FDE [47, p. 172], where the full multipath diversity of three for the considered scenario can be extracted. It is observed that the performance of MMSE-SC-FDE lies within 4 dB of the ML bound.

In Figure 11, we investigate the effect of spatial diversity on the performance of SC-FDE and OFDM. In fact, both schemes benefit from the spatial diversity advantages offered by three receive antennas capturing independently faded replicas of the transmitted signal. Comparing Figure 10 to Figure 11, it is inferred that the performance improvement in OFDM is 17.4 dB at BER = 10^{-3} . In MMSE-SC-FDE, the performance improvement is 11.1 dB. Interestingly, it is observed that the difference between an MMSE-SC-FDE and an ML-SC-

FDE [47] decreases as the number of receive antennas increases. Specifically, for BER = 10^{-3} , the performance of MMSE-SC-FDE is only 1 dB away from the ML bound. This is due to the fact that the performance of a MMSE LE improves with the increasing of the overall SNR, i.e., to the array gain of receive diversity.

A well-known approach to circumvent the diversity loss in OFDM is to employ different constellation sizes and variable powers for the individual subcarriers instead of fixed modulation and equal power. In the so-called adaptive OFDM, the modulation schemes and power allocation are adapted to the channel conditions. Practical implementation of adaptive OFDM requires the estimation of CSI which should be (implicitly or explicitly) fed back to the transmitter for the appropriate choice of transmission parameters in the next signalling interval. Adaptive OFDM may offer a significant performance improvement over its nonadaptive counterpart and also outperforms a SC scheme employing a MMSE-FDE. These results are somewhat optimistic since it is assumed that perfect CSI is readily available at the transmitter side. Practical implementation typically depends on the duplexing method. In time division duplex (TDD) systems, the downlink and uplink channels are often assumed to be the same due to channel reciprocity. Therefore, the base station can obtain the downlink channel information from the received signal through the uplink channel and relies on this estimate for optimization of transmission parameters. In frequency division duplex (FDD) systems, the downlink and uplink channels demonstrate significantly different characteristics.

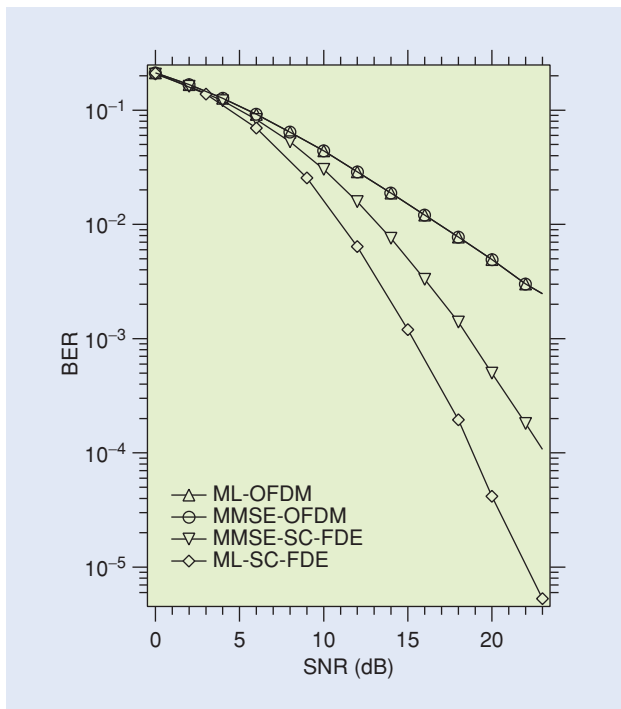

[FIG10] Performance comparison of two SC systems employing FDE with two OFDM systems. Ideal CSI at the receive side and SISO scenario are assumed.

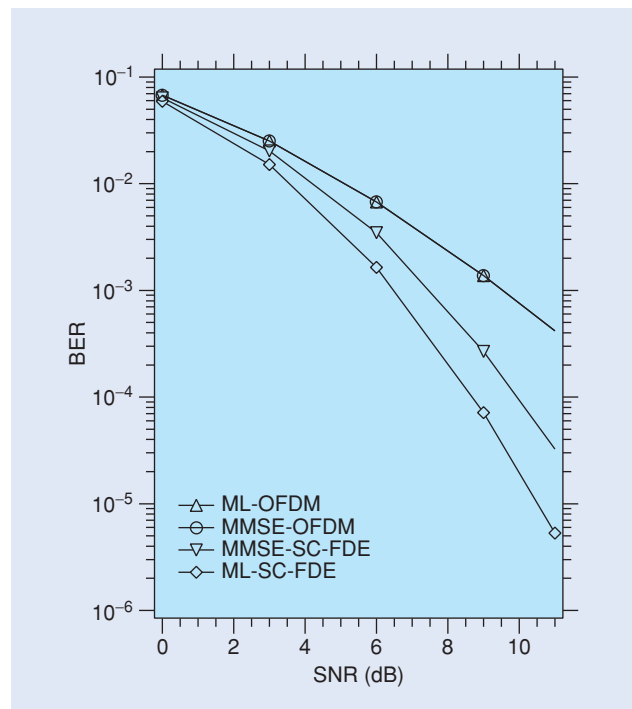

[FIG11] Performance comparison of two SC systems employing FDE with two OFDM systems. Ideal CSI at the receive side and SIMO scenario with three receive antennas are assumed.

Hence, the mobile should transmit the downlink channel information (possibly quantized) through an explicit feedback. The performance of adaptive OFDM can be degraded by various practical implementation considerations including channel estimation error, the feedback delay, quantization error, and Doppler spread in time-selective channels.

In Figure 12, a performance comparison between MMSE SC-FDE and a system employing adaptive OFDM is illustrated assuming multiple receive antennas. These results show that the performance advantages offered by adaptive schemes diminish in the presence of spatial diversity. This observation along with the additional complexity and practical implementation issues make SC-FDE an attractive choice.

So far, our comparisons between OFDM and SC-FDE systems have focused on their error rate performance. Another design concern is the PAPR, which imposes constraints on the choice and design of the high-power amplifier (HPA), which is a critical RF component in terms of cost. OFDM signals exhibit large amplitude variations and therefore suffer from a large PAPR and this results in intercarrier modulation and out-of-band radiation. Unless PAPR reduction techniques are incorporated, this requires a large power backoff in the HPA, significantly reducing its power efficiency. In [48], it is reported that the HPA for OFDM requires a 5.3–9.5 dB backoff as compared to SC schemes, depending on the constellation size. OFDM is also vulnerable to a CFO, that affects subcarrier orthogonality. It produces ICI and acts as a multiplicative noise term, effectively reducing the useful signal amplitude. ICI is obviously not a problem in SC-FDE and the

degrading effect of reduction in the useful signal amplitude has a smaller effect than ICI.

CODED SYSTEMS

One approach to circumvent the multipath diversity loss in uncoded OFDM is the incorporation of channel coding in conjunction with frequency-interleaving among subcarriers. Coded OFDM is able to extract multipath diversity and the achievable diversity order is mainly limited by the outer code structure.

Comparisons of SC-FDE systems with nonadaptive coded OFDM systems have shown that the two systems offer comparable error rate performance [4]. For SISO systems and code rates of about 1/2 or less, nonadaptive coded OFDM shows 0.5 to 1 dB gain in SNR over a coded SC-FDE system using a FD LE [4]. For higher code rates, linearly equalized SC-FDE performs about 1 dB better than the nonadaptive coded OFDM. SC-FDE performance can be further enhanced by the addition of a feedback filter as described in the section “Adaptive FDE-STBC”.

Figure 13 shows the BER performance results for the 2K mode (using an FFT size equal to 2048) for a DVB-H system with SC-FDE at a normalized (with respect to subcarrier spacing) Doppler frequency $F_d = 0.03$. It can be seen that the SC-FDE significantly outperforms OFDM for DVB-H under high mobility conditions that demonstrates the robustness of SC-FDE systems to high mobility. Note also that, for the given Doppler frequency, the 1-tap, 3-tap and 5-tap receivers exhibit similar performance. Moreover, at a BER of 10^{-3} , SC-FDE outperforms OFDM by about 5 dB.

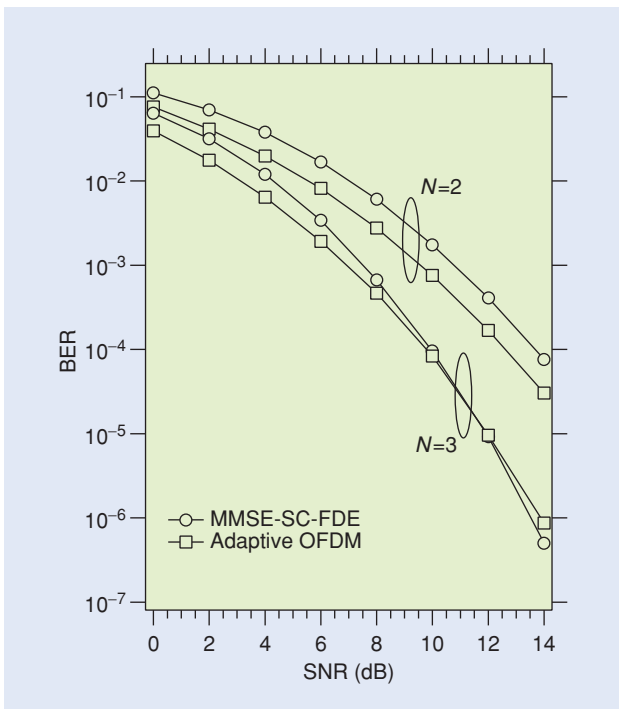

[FIG12] Performance comparison of SC systems employing MMSE FDE with adaptive OFDM systems in SIMO 1×2 and 1×3 scenarios. Ideal CSI at the receive side is assumed.

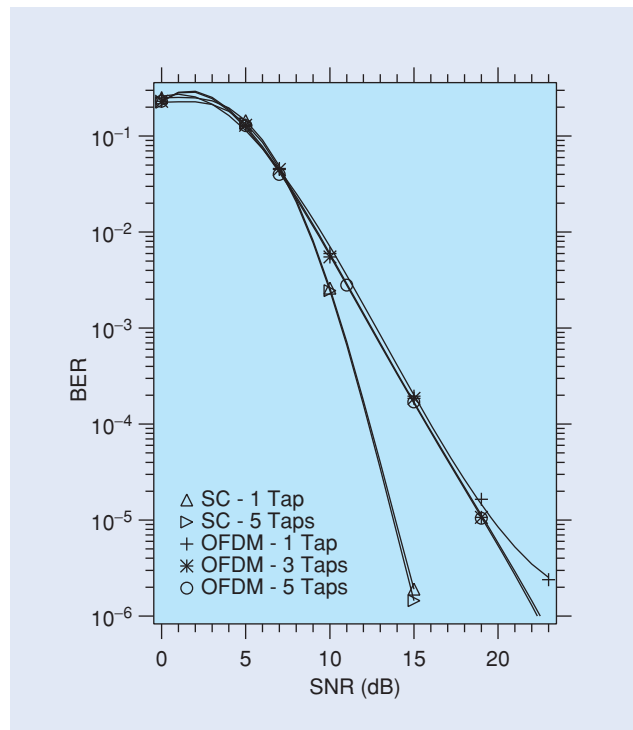

[FIG13] Performance comparison between OFDM and SC-FDE for DVB-H.

Figure 14 shows the average BER for a 4×4 MIMO system using a rate $1/2$ convolutional code and $M = 128$. The transmitted bits are interleaved over ten consecutive blocks. As this figure shows, for this coded system and at low SNRs, the performance of the nonlinear DFE receivers are worse than the linear receiver due to error propagation. Also, for this coded system at BERs below 10^{-2} , the MIMO-DFE performance is 3 dB worse than the LST receiver with five taps, while for uncoded systems they have almost the same performance. This is due to the fact that for the detection of each substream in MIMO-DFE, the nonML decision from all the other streams contribute to the detection process. We observe that both the linear MMSE-SC and LST-SC receivers outperform the corresponding OFDM receivers. Figure 15 depicts the performance of different receivers for a code rate of $3/4$ where the SC-FDE exhibits a large SNR gain over OFDM since it enjoys frequency diversity and the rate $3/4$ code is mainly used to deal with residual ISI and additive noise. In OFDM, this weak error control code tries to improve diversity and deal with interference and additive noise. The situation for OFDM-LST, which is the OFDM counterpart to SC-LST, is worse since the rate $3/4$ code has to cope with error propagation as well since the rate- $1/2$ code mitigates the error propagation more effectively than the rate $3/4$ code for each layer, so the detection of the next layer can enjoy more diversity.

CONCLUSIONS AND FUTURE DEVELOPMENTS

The driving force in today's wireless market is the increasing demand for wireless multimedia and interactive Internet services. OFDM has been widely accepted as a viable solution for such high-speed broadband applications. In this article, we have attempted to present a comprehensive overview of a promising alternative solution, SC-FDE, which has been historically shadowed by OFDM. Although the basic ideas behind SC-FDE can be traced back to Walzman and Schwartz's [2] work on adaptive equalizers in 1973, the recent surge of interest in SC-FDE was subsequent to the work of Sari et al. [6]. SC-FDE enjoys a comparable complexity to OFDM due to the similar transceiver architecture based on efficient FFT/IFFT operations. Owing to the single-carrier implementation, SC-FDE also avoids the inherent drawbacks of OFDM such as amplifier nonlinearities, carrier frequency offsets, and phase noise. OFDM is commonly used in practice in conjunction with coding and/or adaptive modulation. The comparative performance analysis of SC-FDE, coded OFDM, and adaptive OFDM schemes reveals that SC-FDE achieves comparable (or even better in some scenarios) performance compared to its OFDM counterpart. Several aspects in the practical implementation of SC-FDE have been further studied in the recent years including FD channel estimators, non-linear equalizers, training sequence design, interference rejection etc. These recent studies have also successfully integrated SC-FDE in

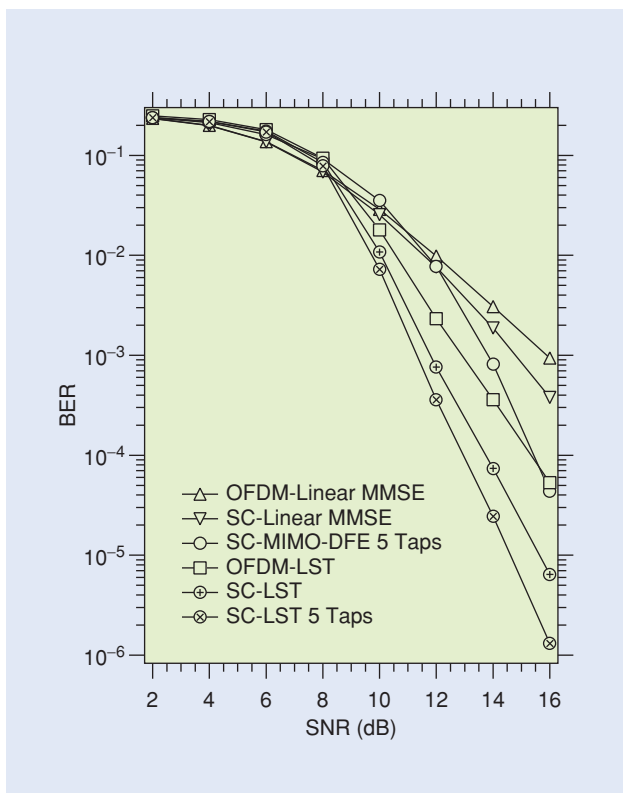

[FIG14] BER performance of various OFDM and SC receivers operating over a 4×4 six-ray channel. Convolutional coding with 64 states and rate $1/2$ is used.

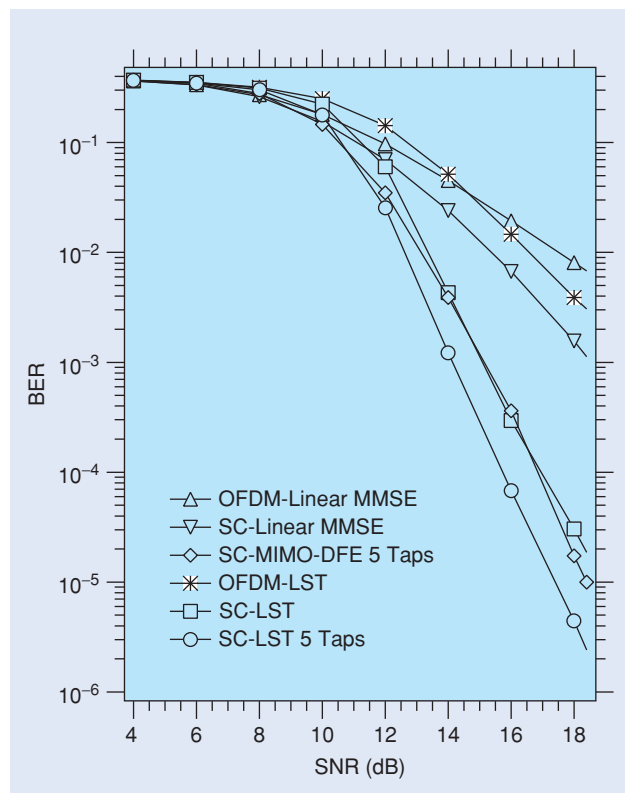

[FIG15] BER performance of various OFDM and SC receivers operating over a 4×4 six-ray channel. Convolutional coding with 64 states rate $3/4$ is used.

STC and spatial-multiplexing systems leveraging the potentials of MIMO communications. The literature on SC-FDE has reached to a certain maturity; however, there are still several open research areas for future work. These include:

- The use of SC-FDE techniques in future-generation multi-band cognitive wireless systems. The interest in this topic is due to the fact that SC-FDE techniques are less sensitive to RF impairment than OFDM; for this reason, they can be applied to multiband transmissions exploiting cognitive radio principles [52].
- The performance analysis of direct sequence CDMA (DS-SS) systems employing SC-FDE and the comparison of such systems with MC-SS techniques. Note that SC-FDE techniques in DS-SS systems should offer a substantially simpler solution than traditional TD-SS receivers.
- The design of noncoherent (and in particular differential) SC-FDE receivers not requiring the knowledge of CSI. Their performance should be compared with that of both channel-estimated-based and adaptive SC-FDE receivers under a variety of operating conditions.

AUTHORS

Fabrizio Pancaldi (fpancaldi@unimore.it) received the Dr.Eng. degree in electronic engineering (cum laude) and the Ph.D. degree in 2006, both from the University of Modena and Reggio Emilia, Italy. Since March 2006, he has held the position of research fellow at the same university. His research interests are in the area of wireless communications, with particular emphasis on detection/equalization techniques and statistical channel modeling. He is a Member of the IEEE.

Giorgio M. Vitetta (vitetta.giorgio@unimo.it) received the Dr. Ing. degree in electronic engineering (cum laude) in 1990 and the Ph.D. degree in 1994, both from the University of Pisa, Italy. From 1995 to 1998, he was a research fellow at the Department of Information Engineering of the University of Pisa. From 1998 to 2001, he was an associate professor of telecommunications at the University of Modena and Reggio Emilia. He is now a full professor of telecommunications in the same university. His main research interests lie in the broad area of communication theory, with particular emphasis on coded modulation, synchronization, statistical modeling of wireless channels, and channel equalization. He is an editor of both the *IEEE Transactions on Communications* and *IEEE Transactions on Wireless Communications* (in the area of transmission systems). He is a Senior Member of the IEEE.

Reza Kalbasi (kalbasi@sce.carleton.ca) received the B.S. and M.S. degrees from Isfahan University of Technology, Isfahan, Iran, in 1994 and 1997 respectively, and the Ph.D. degree in electrical engineering from Carleton University, Ottawa, Canada, in 2005. From 1994 to 2000 he worked at Foolad Technique, Isfahan, Iran in the area of industrial automation and control. From 2005 to 2006, he was a research fellow at the University of Texas at Dallas. Since October 2006, he has been with ArrayComm LLC, San Jose,

California, where he is a system research engineer working on WCDMA system design and analysis. His research interests include equalization, OFDM, and MIMO techniques. He is a Member of the IEEE.

Naofal Al-Dhahir (aldhahir@utdallas.edu) earned his M.S. and Ph.D. degrees from Stanford University in 1990 and 1994, respectively, in electrical engineering. He was an instructor at Stanford University in 1993. From 1994 to 1999, he was with GE R&D Center, New York. From 1999 to 2003, he was with AT&T Shannon Laboratory, Florham Park, New Jersey. In 2003, he joined the University of Texas at Dallas where he is a full professor. He has served as a consultant to the telecommunications industry. His current research interests include space-time coding and signal processing, OFDM, wireless networks, and digital subscriber line technology. He has authored over 175 journal and conference articles and holds 22 U.S. patents. He was an editor for *IEEE Transactions on Signal Processing* and *IEEE Communications Letters*. Currently, he is an editor for *IEEE Transactions on Communications*. He is coauthor of the book *Doppler Applications for LEO Satellite Systems* and is corecipient of the IEEE VTC Fall 2005 Best Paper Award, the 2005 IEEE Signal Processing Society Young Author Best Paper Award, and the 2006 IEEE Donald G. Fink Best Paper Award. He is a Fellow of the IEEE and a member of the IEEE SP4COM and SPTM technical committees.

Murat Uysal (muysal@ece.uwaterloo.ca) received the B.Sc. and the M.Sc. degrees in electronics and communication engineering from Istanbul Technical University, Turkey, in 1995 and 1998, respectively, and the Ph.D. degree in electrical engineering from Texas A&M University, College Station, in 2001. From 1995 to 1998, he was with the Communication Theory Group at Istanbul Technical University. From 1998 to 2002, he was with the Wireless Communication Laboratory, Texas A&M University. Since 2002, he has been with the Department of Electrical and Computer Engineering, University of Waterloo, Canada, where he is now an associate professor. He is an associate editor for *IEEE Transactions on Wireless Communications* and *IEEE Communications Letters*. He has served on the technical program committee of more than 40 international conferences in the communications area. He is a Senior Member of the IEEE.

Hakam Mheidat (hakam.mheidat@utoronto.ca) received his B.Sc. degree from Yarmouk University, Jordan, his M.Sc. degree from University of Wisconsin–Milwaukee, and his Ph.D. degree from University of Waterloo, Canada, in 1995, 1999, and 2006, respectively, all in electrical engineering. From 1997 to 1999, he was with the Signal Processing Group at the University of Wisconsin. From 2003 to 2006, he was with the MIMO Communications Group, University of Waterloo. Since October 2006, he has been with Department of Electrical and Computer Engineering at the University of Toronto, Toronto, Canada, as a postdoctoral fellow. His current research focuses on equalization, multicarrier communication techniques, and physical layer aspects of wideband cooperative networks.

REFERENCES

- [1] R.W. Chang, "Synthesis of band-limited orthogonal signals for multichannel data transmission," *Bell Syst. Tech. J.*, vol. 45, pp. 1775–1796, Apr. 1966.
- [2] T. Walzmann and M. Schwartz, "Automatic equalization using the discrete frequency domain," *IEEE Trans. Inform. Theory*, vol. 19, no. 1, pp. 59–68, Jan. 1973.
- [3] J.G. Proakis, *Digital Communications*, 3rd ed. New York: McGraw-Hill, 1995.
- [4] D. Falconer, S.L. Ariyavitakul, A. Benyamin-Seeyar, and B. Eidson, "Frequency domain equalization for single-carrier broadband wireless systems," *IEEE Commun. Mag.*, vol. 40, no. 4, pp. 58–66, Apr. 2002.
- [5] J.J. Shynk, "Frequency-domain and multirate adaptive filtering," *IEEE Signal Processing Mag.*, vol. 9, no. 1, pp. 14–37, Jan. 1992.
- [6] H. Sari, G. Karam, and I. Jeanclaude, "Transmission techniques for digital terrestrial TV broadcasting," *IEEE Commun. Mag.*, vol. 33, no. 2, pp. 100–109, Feb. 1995.
- [7] N. Al-Dhahir, "Single-carrier frequency-domain equalization for space-time block-coded transmissions over frequency-selective fading channels," *IEEE Commun. Lett.*, vol. 5, no. 7, pp. 304–306, July 2001.
- [8] A. Gusmão, R. Dinis, and N. Esteves, "On frequency-domain equalization and diversity combining for broadband wireless communications," *IEEE Commun. Lett.*, vol. 51, no. 7, pp. 1029–1033, July 2003.
- [9] R. Dinis, R. Kalbasi, D. Falconer, and A.H. Banihashemi, "Iterative layered space-time receivers for single-carrier transmission over severe time-dispersive channels," *IEEE Commun. Lett.*, vol. 8, no. 9, pp. 579–581, Sept. 2004.
- [10] F. Pancaldi and G.M. Vitetta, "Block channel equalization in the frequency domain," *IEEE Trans. Commun.*, vol. 53, no. 3, pp. 463–471, Mar. 2005.
- [11] F. Pancaldi and G.M. Vitetta, "Frequency domain equalization for space-time block coded systems," *IEEE Trans. Wireless Commun.*, vol. 4, no. 6, pp. 2907–2916, Nov. 2005.
- [12] F. Pancaldi and G.M. Vitetta, "Equalization algorithms in the frequency domain for continuous phase modulations," *IEEE Trans. Commun.*, vol. 54, no. 4, pp. 648–658, Apr. 2006.
- [13] H. Mheidat, M. Uysal, and N. Al-Dhahir, "Equalization techniques for distributed space-time block codes with amplify-and-forward relaying," submitted for publication.
- [14] R. Kalbasi, R. Dinis, D. Falconer, and A. Banihashemi, "Hybrid time-frequency layered space-time receivers for severe time-dispersive channels," in *Proc. IEEE 5th Workshop Signal Processing Advances in Wireless Communications (SPAWC'04)*, May 2004, pp. 218–222.
- [15] J. Tan and G.L. Stüber, "Frequency domain equalization for continuous phase modulation," *IEEE Trans. Wireless Commun.*, vol. 4, no. 5, pp. 2479–2490, Sept. 2005.
- [16] T. Aulin and C.E.W. Sundberg, "Continuous phase modulation—Part I: Full response signaling," *IEEE Trans. Commun.*, vol. 29, no. 3, pp. 196–209, Mar. 1981.
- [17] T. Aulin, N. Rydbeck, and C.E.W. Sundberg, "Continuous phase modulation—Part II: Partial response signaling," *IEEE Trans. Commun.*, vol. 29, no. 3, pp. 210–225, Mar. 1981.
- [18] D. Falconer and S.L. Ariyavitakul, "Broadband wireless using single carrier and frequency domain equalization," in *Proc. IEEE 5th Int. Symp. Wireless Personal Multimedia Communication*, vol. 1, Oct. 2002, pp. 27–36.
- [19] C.T. Lam, D. Falconer, F. Danilo-Lemoine, and R. Dinis, "Channel estimation for SC-FDE systems using frequency domain multiplexed pilots," in *Proc. IEEE 64th Vehicular Technology Conference 2006 Fall (VTC'06 Fall)*, Montreal, Quebec, Canada, Sept. 2006.
- [20] R. Kalbasi, R. Dinis, D. Falconer, and A. Banihashemi, "Channel estimation for MIMO systems employing single-carrier modulations with iterative frequency-domain equalization," in *Proc. IEEE 60th Vehicular Technology Conf. 2004 Fall (VTC'04 Fall)*, vol. 7, pp. 4942–4946.
- [21] J. Siew, J. Coon, R.J. Piechocki, A. Dowler, A. Nix, M. Beach, S. Armour, and J. Mc Geehan, "A channel estimation algorithm for MIMO-SCFDE," *IEEE Commun. Lett.*, vol. 8, no. 9, pp. 555–557, Sept. 2004.
- [22] N. Benvenuto and S. Tomasin, "On the comparison between OFDM and single carrier modulation with a DFE using a frequency-domain feedforward filter," *IEEE Trans. Commun.*, vol. 50, no. 6, pp. 947–955, June 2002.
- [23] Y. Zhu and K.B. Letaief, "Single carrier frequency domain equalization with noise prediction for broadband wireless systems," in *Proc. IEEE Global Telecommunications Conf. (GLOBECOM'04)*, vol. 5, Nov. 2004, pp. 3098–3102.
- [24] P. Schniter and H. Liu, "Iterative equalization for single-carrier cyclic-prefix in doubly-dispersive channels," in *Proc. 38th Asilomar Conf. Signals, Systems and Computers*, vol. 1, Nov. 2004, pp. 667–671.
- [25] B.K. Ng and D. Falconer, "A novel frequency domain equalization method for single-carrier wireless transmissions over doubly-selective fading channels," in *Proc. IEEE Global Telecommunications Conf. (GLOBECOM'04)*, vol. 1, Nov. 2004, pp. 237–241.
- [26] H. Mheidat, M. Uysal, and N. Al-Dhahir, "Time- and frequency-domain equalization for quasi-orthogonal STBC over frequency-selective channels," in *Proc. IEEE Int. Conf. Communications (ICC'04)*, vol. 2, June 2004, pp. 697–701.
- [27] J.H. Jang, H.C. Won, and G.H. Im, "Cyclic prefixed signal carrier transmission with SFBC over mobile wireless channels," *IEEE Signal Processing Lett.*, vol. 13, no. 5, pp. 261–264, May 2006.
- [28] L. Liu and F. Adachi, "Joint frequency-domain differential detection and equalization for DS-CDMA signal transmissions in a frequency-selective fading channel," *IEEE J. Select. Areas Commun.*, vol. 24, no. 3, pp. 649–658, Mar. 2006.
- [29] Y. Wang and X. Dong, "A time-division multiple-access SC-FDE system with IBI suppression for UWB communications," *IEEE J. Select. Areas Commun.*, vol. 24, no. 4, pp. 920–926, Apr. 2006.
- [30] P. Vandenameele, L. Van der Perre, B. Gyselinckx, M. Engels, M. Moonen, and H. De Man, "A single-carrier frequency-domain SDMA base station," in *Proc. IEEE Int. Conf. Acoustic, Speech and Signal Processing (ICASSP'00)*, vol. 6, June 2000, pp. 3714–3717.
- [31] M.V. Clark, "Adaptive frequency-domain equalization and diversity combining for broadband wireless communications," *IEEE J. Select. Areas Commun.*, vol. 16, no. 8, pp. 1385–1395, Oct. 1998.
- [32] W.M. Younis, A.H. Sayed, and N. Al-Dhahir, "Efficient adaptive receivers for joint equalization and interference cancellation in multiuser space-time block-coded systems," *IEEE Trans. Signal Processing*, vol. 51, no. 11, pp. 2849–2862, Nov. 2003.
- [33] Y.G. Yang, N.I. Cho, and S.U. Lee, "Fast blind equalization by using frequency domain block constant modulus algorithm," in *Proc. IEEE Int. Symp. Circuits and Systems (ISCAS'95)*, vol. 2, Aug. 1995, pp. 1003–1006.
- [34] J. Gunther and A. Swindlehurst, "Algorithms for blind equalization with multiple antennas based on frequency domain subspaces," in *Proc. IEEE Int. Conf. Acoustic, Speech and Signal Processing (ICASSP'96)*, vol. 5, May 1996, pp. 2419–2422.
- [35] J.Y. Wu and T.S. Lee, "Periodic-modulation-based blind channel identification for single-carrier block transmission with frequency-domain equalization," *IEEE Trans. Signal Processing*, vol. 54, no. 3, pp. 1114–1130, Mar. 2006.
- [36] M.V. Eyuboglu, "Detection of coded modulation signals on linear severely distorted channels using decision-feedback noise prediction with interleaving," *IEEE Trans. Commun.*, vol. 36, no. 4, pp. 401–409, Apr. 1988.
- [37] J. Tubbs, L. Vanderperre, S. Donnay, and M. Engels, "Single-carrier communications using decision-feedback equalization for multiple antennas," in *Proc. IEEE Int. Conf. Communications (ICC'03)*, vol. 4, May 2003, pp. 2321–2325.
- [38] R. Kalbasi, "Frequency domain processing for MIMO Channels," Ph.D. dissertation, Dept. Systems Computer Eng., Carleton Univ., Ottawa, Ontario, Canada, Sept. 2005.
- [39] A. Duel-Hallen, "A family of multiuser decision-feedback detectors for asynchronous code-division," *IEEE Trans. Commun.*, vol. 43, no. 2/3/4, pp. 421–434, 1995.
- [40] N. Al-Dhahir and A. H. Sayed, "The finite-length multi-input, multi-output MMSE-DFE," *IEEE Trans. Signal Processing*, vol. 48, no. 10, pp. 2921–2936, Oct. 2000.
- [41] S. Roy and D. Falconer, "Multi-user decision-feedback space-time processing with partial cross-feedback connectivity," in *Proc. IEEE 51th Vehicular Technology Conf. 2000 Spring (VTC'00 Spring)*, vol. 3, pp. 2172–2177.
- [42] M. Tüchler and J. Hagenauer, "Linear time and frequency domain turbo equalization," in *Proc. IEEE 53rd Vehicular Technology Conf. 2001 Spring (VTC'01 Spring)*, vol. 2, pp. 1449–1453.
- [43] H. Jafarkhani, "A quasi-orthogonal space-time block code," *IEEE Trans. Commun.*, vol. 49, no. 1, pp. 1–4, Jan. 2001.
- [44] W. Su and X.G. Xia, "Signal constellations for quasi-orthogonal space-time block codes with full diversity," *IEEE Trans. Inform. Theory*, vol. 50, no. 10, pp. 2331–2347, Oct. 2004.
- [45] J.N. Laneman, D.N.C. Tse, and G.W. Wornell, "Cooperative diversity in wireless networks: efficient protocols and outage behavior," *IEEE Trans. Inform. Theory*, vol. 50, no. 12, pp. 3062–3080, Dec. 2004.
- [46] R. Nabar, H. Bolcskei, and F. Kneubühler, "Fading Relay Channels: Performance limits and space-time signal design," *IEEE J. Select. Areas Commun.*, vol. 22, no. 6, pp. 1099–1109, Aug. 2004.
- [47] S. Zhou and G.B. Giannakis, "Single-carrier space-time block-coded transmissions over frequency-selective fading channels," *IEEE Trans. Inform. Theory*, vol. 49, no. 1, pp. 164–179, Jan. 2003.
- [48] M. Sabbaghian and D. Falconer, "Reducing required power back-off of non-linear amplifier in serial modulation using SLM methods," in *Proc. IEEE 62nd Vehicular Technology Conf. 2005 Fall (VTC'05 Fall)*, vol. 3, pp. 1882–1886.
- [49] J.-H. Jang, H.-C. Won, and G.-H. Im, "Cyclic prefixed single carrier transmission with SFBC over mobile wireless channels," *IEEE Signal Processing Lett.*, vol. 13, no. 5, pp. 261–264, May 2006.
- [50] R. Kalbasi, R. Dinis, D. Falconer, and A. Banihashemi, "Frequency-domain space-time precoders for severe time-dispersive channel employing single-carrier modulations," in *Proc. IEEE 61st Vehicular Technology Conf. 2005 Spring (VTC'05 Spring)*, vol. 2, pp. 1215–1219.
- [51] W.S. Leon and Y.C. Liang, "Blind frequency domain equalization for CP-CDMA downlink," in *Proc. IEEE 62nd Vehicular Technology Conf. 2005 Fall (VTC'05 Fall)*, vol. 1, pp. 114–117.
- [52] D. Falconer and M. Muck, "Feasibility of multi-bandwidth transmission in future broadband wireless systems," in *Proc. Information Society Technologies (IST) Summit*, Dresden, Germany, June 2005, pp. 19–23.
- [53] H.G. Myung, J. Lim, and D.J. Goodman, "Single carrier FDMA for uplink wireless transmission," *IEEE Veh. Technol. Mag.*, vol. 1, no. 3, pp. 30–38, Sept. 2006. **SP**