

3D Body & Medical Scanners' Technologies: Methodology and Spatial Discriminations

Julio C. Rodríguez-Quiñonez¹, Oleg Sergiyenko¹, Vera Tyrsa²,
Luís C. Básaca-Preciado¹, Moisés Rivas-Lopez¹,

Daniel Hernández-Balbuena¹ and Mario Peña-Cabrera³

¹*Autonomous University of Baja California, Mexicali-Ensenada,*

²*Polytechnic University of Baja California, Mexicali,*

³*Research Institute of Applied Mathematics and Systems (IIMAS – UNAM)
Mexico*

1. Introduction

Medical practitioners have traditionally measured the body's size and shape by hand to assess health status and guide treatment. Now, 3D body-surface scanners are transforming the ability to accurately measure a person's body size, shape, and skin-surface area (Treleaven & Wells, 2007) (Boehnen & Flynn, 2005). In recent years, technological advances have enabled diagnostic studies to expose more detailed information about the body's internal constitution. MRI, CT, ultrasound and X-rays have revolutionized the capability to study physiology and anatomy in vivo and to assist in the diagnosis and monitoring of a multitude of disease states. External measurements of the body are more than necessary. Medical professionals commonly use size and shape to production of prostheses, assess nutritional condition, developmental normality, to analyze the requirements of drug, radiotherapy, and chemotherapy dosages. With the capability to visualize significant structures in great detail, 3D image methods are a valuable resource for the analysis and surgical treatment of many pathologies.

Taxonomy of Healthcare 3D Scanning applications				
Application	Epidemiology	Diagnosis	Treatment	Monitoring
Size	Anthropometric surveys	Growth defects	Scoliosis	Fitness and diet
Shape	Screening	Abdominal shape	Prosthetics	Obesity
Surface area		Lung volume	Drug dosage	Diabetes
Volume	Eczema		Burns	
Head Visualization		Melanomas	Eating disorders	
Chest Visualization			Facial reconstruction	
Hole Body Visualization			Cosmetic surgery	

Table 1. Taxonomy of Healthcare 3D Scanning applications

1.1 Scanning technologies

Three-dimensional body scanners employ several technologies including 2D video silhouette images white light phase measurement, laser-based scanning, and radio-wave linear arrays. Researchers typically developed 3D scanners for measurement (geometry) or visualization (texture), using photogrammetry, lasers, or millimeter wave (Treleven & Wells, 2007).

Taxonomy of 3D Body Scanners		
Technique	Measurement	Visualization
Millimeter Wave	Radio Waves	
Photogrammetry	Structured light	Close-range photogrammetry
	Moire fringe contouring	Digital surface
	Phase - measuring profilometry	photogrammetry
Laser	Laser Scanners	
	Laser range Scanners	

Table 2. Taxonomy of 3D Body Scanners

In the following section it will be described the diverse measurement techniques (see table 2) used in medical and body scanners. Listing applications, scanners types and common application areas, as well of how they operate.

2. Millimeter wave

Millimeter wave based scanners, send a safe, lower radio wave toward a person’s fully clothed body; most of the systems irradiate the body with extremely low-powered millimeter waves a class of non-ionizing radiation (see Figure 1) not harmful to humans. The amount of radiation emitted in the millimeter-wave range is 10^8 times smaller than the amount emitted in the infrared range. However, current millimeter-wave receivers have at least 10^5 times better noise performance than infrared detectors and the temperature contrast recovers the remaining 10^3 . This makes millimeter-wave imagine comparable in performance with current infrared systems.

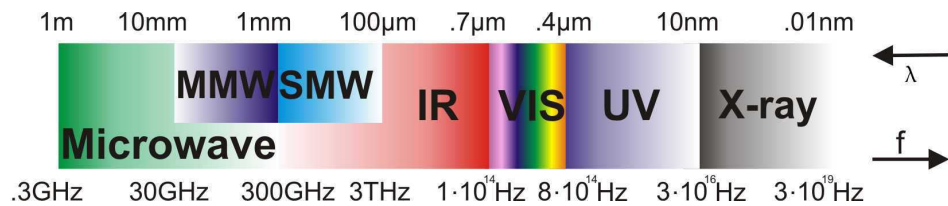

Fig. 1. Electromagnetic spectrum showing the different spectral bands between the microwaves and the X-rays

Millimeter (MMW) and Submillimeter (SMW) waves fill the gap between the IR and the microwaves (see Figure 1). Specifically, millimeter waves lie in the band of 30-300 GHz (10-1 mm) and the SMW regime lies in the range of 0.3-3 THz (1-0.1 mm). MMW and SMW radiation can penetrate through many commonly used nonpolar dielectric materials such as

paper, plastics, wood, leather, hair and even dry walls with little attenuation (Howald et al., 2007) (Liu et al., 2007). Clothing is highly transparent to the MMW radiation and partially transparent to the SMW radiation (Bjarnason et al., 2004). Consequently, natural applications of MMW and SMW imaging include security screening, nondestructive inspection, and medical and biometrics imaging. Low visibility navigation is another application of MMW imaging

Is also true that MMW and SMW open the possibility to locate threats on the body and analyze their shape, which is far beyond the reach of conventional metal detection portals. A recently demonstrated proof-of-concept sensor developed by QinetiQ provides video-frame sequences with near-CIF resolution (320×240 pixels) and can image through clothing, plastics and fabrics. The combination of image data and through-clothes imaging offers potential for automatic covert detection of weapons concealed on human bodies via image processing techniques (Haworth et al., 2006). Other potential areas of application are mentioned below.

Medical: provide measurements of individuals who are not mobile and may be difficult to measure for prosthetic devices.

Ergonomic: provide measurements and images for manufacturing better office chairs, form-fitting car and aviation seats, cockpits, and custom sports equipment.

Fitness: provide personal measurements and weight scale for health and fitness monitoring.

2.1 3D Body millimeter wave scanner: Intellifit system

The vertical wand in the Intellifit system (see Figure 2) contains 196 small antennas that send and receive low-power radio waves. In the 10 seconds it takes for the wand to rotate around a clothed person, the radio waves send and receive low-power signals. The signals don't "see" the person's clothing, but reflect off the skin, which is basically water (Treleven & Wells, 2007). The technology used with the Intellifit System is safer than using a cell phone. The millimeter waves are a form of non-ionizing radiation, which are similar to cell phone signals but less than 1/350th of the power of those signals, and they do not penetrate the skin. When the wand's rotation is complete, Intellifit has recorded over 200,000 points in space, basically x, y, and z coordinates. Intellifit software then electronically measures the "point-cloud", producing a file of dozens of body measurements; the raw data is then discarded.



Fig. 2. Intellifit System, cloth industry application and point cloud representation of the system

Although the system is functional to obtain a silhouette of the body, object detection as a security system and as a tool in the cloth design industry, the problem of this system is the inaccurate measurements that are closed to 1cm, which makes the system not appropriate for medical applications.

3. Photogrammetry

Photogrammetry is the process of obtaining quantitative three-dimensional information about the geometry of an object or surface through the use of photographs (Leifer, 2003). Photogrammetric theories have on a long history of developments for over a century. Intensive research has been conducted for the last 20 years for the automation of information extraction from digital images, based on image analysis methods (Emmanuel, 1999). In order for a successful three-dimensional measurement to be made, targeting points, each of which is visible in two or more photographs, are required. These targets can be unique, well-defined features that already exist on the surface of the object, artificial marks or features attached to the object, or a combination of both types. The accuracy of the reconstruction is directly linked to the number and location of the targets, as well as number of photographs and camera positions chosen. Intricate objects generally require more targets and photographs for a successful reconstruction than do flat or near-flat surfaces. (Leifer, 2003). The latest shift in photogrammetry has been the passage to fully digital technologies. In particular, low cost digital cameras with high pixel counts (> 6 mega-pixels image sensors), powerful personal computers and photogrammetric software are driving a lot of new applications for this technology. (Beraldin, 2004). As shown in Table 2, the measurement photogrammetry techniques can be refer as show below.

3.1 Structured-light systems

One of the simplest systems consists of a projector that emits a stripe (plane) of light and a camera placed at an angle with respect to the projector as shown in Figure 3. At each point

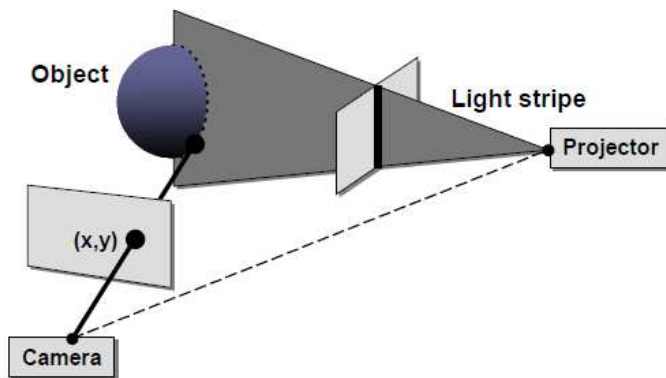

Fig. 3. Schematic layout of a single-camera, single-stripe-source triangulation system in time, the camera obtains 3D positions for points along a 2D contour traced out on the object by the plane of light. In order to obtain a full range image, it is necessary either to

sweep the stripe along the surface (as is done by many commercial single-stripe laser range scanners) or to project multiple stripes. Although projecting multiple stripes leads to faster data acquisition, such a system must have some method of determining which stripe is which (Rusinkiewicz et al., 2002). There are three major ways of doing this: assuming surface continuity so that adjacent projected stripes are adjacent in the camera image, differentiating the stripes based on color, and coding the stripes by varying their illumination over time. The first approach (assuming continuity) allows depth to be determined from a single frame but fails if the surface contains discontinuities. Using color allows more complicated surfaces but fails if the surface is textured. Temporal stripe coding is robust to moderate surface texture but takes several frames to compute depth and, depending on the design, may fail if the object moves (Rusinkiewicz et al., 2002).

3.1.1 Body and medical 3D structured light scanner: Formetric 3D/4D

The system Formetric 3D/4D is based on structured light projection. The scanning system consists of four main components: electro-mechanical elevating column for height adjustment, projector, camera and software. The projection unit emits a white light grid onto the dorsal surface of the patient standing in a defined way toward the projection device, which then obtains measuring data on the dorsal profile by means of a video-optic device from another direction (Hierholzer & Drerup, 1995). Rasterstereography excels by its precision (methodic error < 0.1 mm) and allows a radiation-free representation of the profile. For angular data, the reproducibility of an individual rasterstereographic shot is indicated with 2.8°. The measuring speed of 0.04 seconds can be considered as quick, and the total dorsal surface is registered simultaneously (Lippold et al., 2007). An automatic recognition of anatomical structures by means of the connected software provides the basis for a reconstruction of the three-dimensional profile of the dorsal surface. Figure 4 shows the Formetric 3D/4D Scanning System. By means of mathematical algorithms, a two-dimensional median sagittal or frontal-posterior dorsal profile is generated (Lippold et al., 2007). The gained information is of use for analysis and diagnosis.



Fig. 4. Formetric 3D/4D Scanning System

However, one of the disadvantages of this procedure is when a 360° view of an object is required; it is unable to use simultaneously multiple systems around the object because of interference between multiple light projections. It can give inaccurate data. Although, multiple systems use in sequence will increment the scanning time.

3.2 Moiré fringe counteracting

In optics moiré refers to a beat pattern produced between two gratings of approximately equal spacing. It can be seen in everyday things such as the overlapping of two window screens, the rescreening of a half-tone picture, or with a striped shirt seen on television (Creath & Wyant, 1992). The moiré effect is obtained as a pattern of clearly visible fringes when two or more structures (for example grids or diffraction gratings) with periodic geometry are superimposed. It has also been verified that the obtained fringes are a measure of the correlation between both structures. Additionally, it has been shown that the moiré effect can be obtained when other types of structures are superimposed, such as random and quasi-periodic ones or fractals. Fringe projection entails projecting a fringe pattern or grating over an object and viewing it from a different direction. It is a convenient technique for contouring objects that are too coarse to be measured with standard interferometry. A simple approach for contouring is to project interference fringes or a grating onto an object and then view it from a different direction (Calva et al., 2009). The first use of fringe projection for determining surface topography was presented by Rowe and Welford in 1967. Fringe projection is related to optical triangulation using a single point of light and light sectioning where a single line is projected onto an object and viewed in a different direction to determine the surface contour. Moiré and fringe projection interferometry complement conventional holographic interferometry, especially for testing optics to be used at long wavelengths. Although two-wavelength holography (TWH) can be used to contour surfaces at any longer-than-visible wavelength, visible interferometry environmental conditions are required. Moiré and fringe projection interferometry can contour surfaces at any wavelength longer than 10-100 μm with reduced environmental requirements and no intermediate photographic recording setup (Creath & Wyant, 1992). However doesn't exist commercial scanners who take advantage of the combine technique of moiré fringe.

3.3 Phase Measuring Profilometry (PMP)

A well-known non-contact 3D measurement technique has been extensively developed to meet the demands of various applications. In such system (see Figure 5), generally, periodic

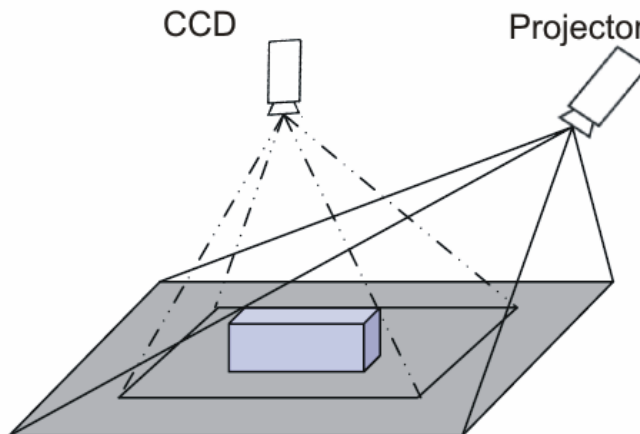

Fig. 5. The Phase Measuring Profilometry system

fringe patterns are projected on the objects surface, and the distorted patterns caused by the depth variation of the surface are recorded. The phase distributions of the distorted fringe patterns are recovered by phase-shifting technique or the method based on Fourier transformation analysis and then the depth map of the object surface is further reconstructed. Currently, light pattern is designed and generated by computer and Digital Light Projector (DLP) is popularly used to project the periodic sinusoidal fringe patterns on object surfaces. It is more flexible and accurate than conventional approaches in which grating is used for generating the sinusoidal fringe images. However, some problems still exist in PMP using DLP. One of them is that the inherent gamma nonlinearity of the DLP and CCD camera affects the output. As a result, the actual obtained fringe waveform is nonsinusoidal (Di & Naiguang 2008).

3.3.1 White light scanners by 3D3 solutions

The scanning system (see figure 6) consists of three main components: Projector (2200 Lumens to 2700 Lumens, 1024 + resolution), two 5MP high-speed HD machine vision cameras and a PC with FlexScan3D image capture software. The scanner use a projector to emit a white light pattern on to the surface of an object, two simple video cameras placed at different position scan the object and the software by triangulation of patterns renders the model in three dimensions. The first step in the scan procedure is the camera calibration using a pattern board, which the software needs to interpret the position of both cameras. When the pattern is projected the cameras provide the information to the software and render the image. The system needs a minimal 4 scans for a 360° view and is Recommended 8 scans for a full 360° view, the working range is 0.4 meters to 5 meters, and the scan speed is 1 to 6 seconds depending on scanner configuration. The common applications are: scanning faces for cosmetic surgery and burn treatments (in table 1 are presented medical applications for 3D scanners), bracing products (Knees, elbows and ankles), dental scanning replaces the need to create physical dental molds for patients.

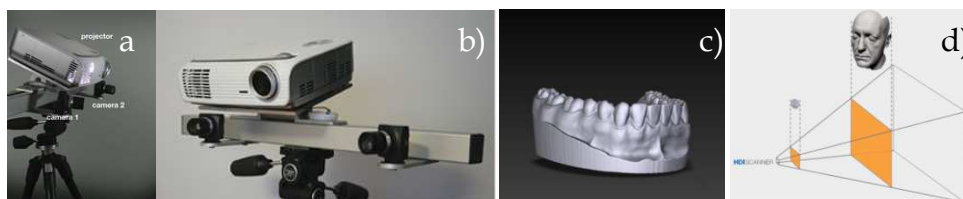

Fig. 6. a) Right view of 3D3 scanning system b) Front View of scanning system c) Dental scanning d) Field of view and face scanning

However this system only generates a 3D image and does not give as an output dimension measurements.

4. Laser scanning

Most of the contemporary non-contact 3D measurement devices are based on laser range scanning. The simplest devices, and also the least reliable, are based on the triangulation method. Laser triangulation is an active stereoscopic technique where the distance of the object is computed by means of a directional light source and a video camera. A laser beam is deflected from a mirror onto a scanning object. The object scatters the light, which is then

collected by a video camera located at a known triangulation distance from the laser (Azernikov & Fischer, 2008). Using trigonometry, the 3D spatial (XYZ) coordinates of a surface point are calculated. The charged couple device (CCD) camera's 2D array captures the surface profile image and digitizes all data points along the laser. The disadvantage of this method is that a single camera collects only a small percentage of the reflected energy. The amount of collected energy can be drastically increased by trapping the whole reflection conus. This improvement significantly increases the precision and reliability of the measurements. The measurement quality usually depends on surface reflection properties and lighting conditions. The surface reflection properties are dictated by a number of factors: a) angle of the laser ray hitting, b) surface material, and c) roughness. Owing to these factors, with some systems the measured object must be coated before scanning. More advanced systems provide automatic adaptation of the laser parameters for different surface reflection properties (Azernikov & Fischer, 2008).

There are a number of laser scanning systems on the market specifically engineered to scan manufactured parts smaller (10" L x 10" W x 16" H) than the human body. These systems are smaller than the typical laser body scanners mentioned below and employ a different scanning mechanism. The industrial units may pass a single laser stripe over the part or object multiple times at different orientations or rotate the part on a turntable. The smaller systems often have increased accuracy and resolution in their measurements when compared to their larger counterparts because of their reduced size and different scanning mechanisms. (Lerch et al., 2007)

4.1 Spatial discrimination

Given the nature of light there are discriminations to be performed in laser scanning systems, for example even in the best emitting conditions (single mode), the laser light does not maintain collimation with distance (e.g. check the beam divergence on scanner specifications sheets). In fact, the smaller the laser beam, the larger is the divergence produced by diffraction. For most laser scanning imaging device, the 3D sampling properties can be estimated using the Gaussian beam (see Figure 7) propagation formula and the Rayleigh criterion. This is computed at a particular operating distance, wavelength and desired spot size within the volume. Figure 4 illustrates that constraint ($\lambda = 0.633 \mu\text{m}$) (Beraldin, 2004).

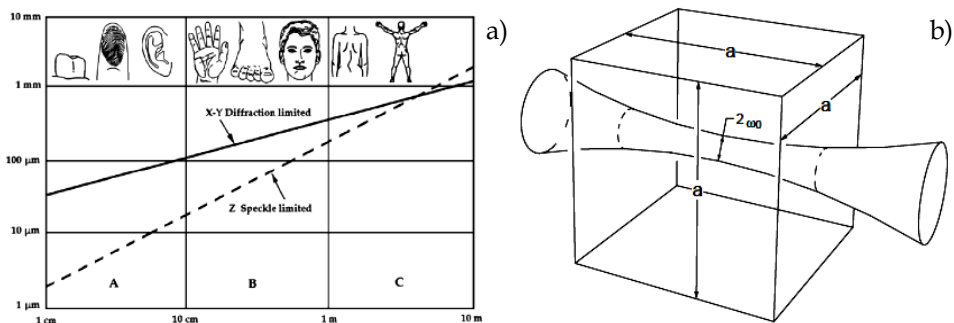

Fig. 7. a) Physical limits of 3D laser scanners as a function of volume measured. Solid line: X-Y spatial resolution limited by diffraction, Dashed line: Z uncertainty for triangulation-based systems limited by speckle. b) Gaussian Beam (Beraldin, 2004)

4.2 Body and medical 3D laser scanners

Of the diverse current methods for body scanning, laser scanners are used to graphically represent the silhouette and perform accurate measurements. The following systems are appropriate to perform the representation task but they have disadvantages which can decrease its measurement precision.

4.2.1 Vitus Smart 3D laser scanner

The scanning system developed by Human Solutions consists of two main components: the scanning assembly or booth and a PC with image reconstruction software. The scanning assembly is 4' wide by 4' deep by 10' high. (See figure 8) with a structural frame to keep the device stationary; curtains are hung from the frame to minimize outside light. Located in each of the four corners is a vertical column containing the essential scanning equipment: a low energy laser, and two charge coupled device (CCD) cameras, all of which ride together in an elevator assembly that travels up and down in the vertical column. When the system is calibrated correctly, the four elevator assemblies travel down the columns in unison, sweeping the scanning zone with a horizontal plane of laser light.

The laser light illuminates the contours of an object standing within the scanning zone and the CCD cameras record discrete points on these contours at each horizontal plane. The entire scan takes approximately 12 seconds (Lerch et al., 2007).



Fig. 8. Vitus 3D Laser Scanning

A computer attached to the scanner contains the user interface, data acquisition/reconstruction, and data analysis software, while interfacing with the motor controller. The computer software acquires data from the A/D converter and triangulates the discrete points for all of the horizontal planes, creating a point cloud representation of the object scanned. This process takes approximately 2 minutes to complete. After the data acquisition/reconstruction program is completed, a 3D image of the object is displayed on the computer screen. The point cloud data can be exported into proprietary and standard file formats (obj. dxf sdl. ascii) which can be imported into various computer aided design (CAD), finite element analysis (FEA). and rapid prototyping software packages (Lerch et al., 2007).

The elevated production costs of hardware components for the Vitus 3D Laser Scanning could be considered as a disadvantage. Moreover, precision electric motors should be used

for the displacement of the scanner units. Lastly, the whole scanner system must be calibrated so that the geometrical disposition of all the elements can be accurately determined. Any error in calibration will result in inaccurate measurements because there is no gap uncertainty in the calibration.

4.2.2 Konica Minolta 910

The Vivid 910 scanner (see figure 9) from Konica Minolta consists on a single camera and laser stripe, and acquires 3D data using triangulation. According to Konica the scanning process is comfortable, although subjects can see a quick flash of red when the laser stripe crosses the pupil. The laser is eye safe so the subject's eyes can remain open during scanning. The scan takes approximately 2.5 seconds and the subject must remain motionless during that time or a poor scan will result. The Vivid 910 managed to be accurate with a repeatability of 0.003 mm. (Boehnen & Flynn, 2005). There are three different zoom lenses available and an automatic focus system that allows scanning at a wide variety of distances from the camera (there is a tradeoff between image resolution and standoff). It is somewhat sensitive to lighting conditions and is necessary to operate on indoors environments (Boehnen & Flynn, 2005).

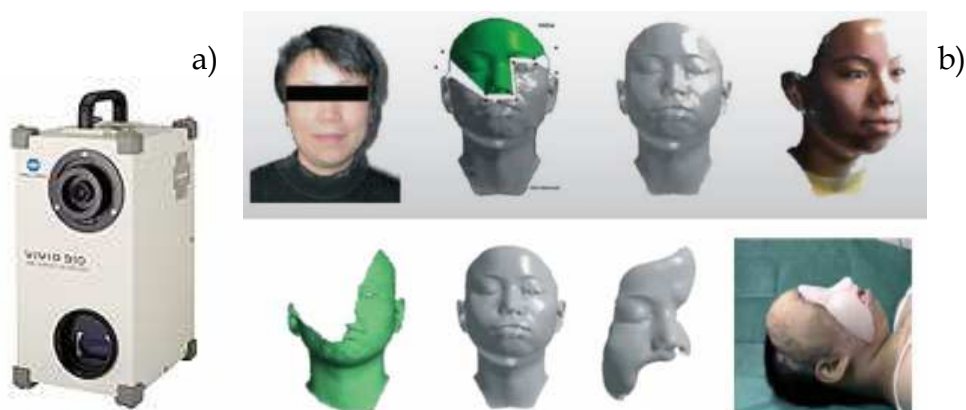

Fig. 9. a) Vivid 910 b) Rough procedures to create the missing part for visualization using Vivid scanner

4.2.3 3D Dynamic Triangulation scanner

The scanning system consists of four main components: electro-mechanical inclining angle system, laser beam projector, photodetector and software. A laser beam is projected onto the body and is detected by a photodetector which sets the angle of incidence. The system has a rotating system that allows inclining the angle for a complete scan. The system reduces measurement error because doesn't have independent elements to coordinate like Vitus Smart. The precision is 0.04 mm and allows a radiation-free representation of the profile.

The laser and the collimator are installed in own laser positioning system (PL) see figure 10. PL has its step drive, which on a command from the onboard computer can turn PL in a horizontal plane at each for one angle pitch (Rivas et al., 2008). On the other end of the bar is

located a scanning aperture (SA) (Sergiyenko et al, 2009). B_i is the angle detected and C_i is the output angle of the laser. The system works in the next way. By the command from the computer the bar is installed so that the SA rotation axis becomes perpendicular to plane XOY of reference system. PL puts the laser with the collimator, for example, in an extreme right position. The axis of the collimator (with the help of PV-step drive) then takes extreme top position (above the horizon). The laser and the SA are switched on. SA is rotated by the electromotor EM. At each SA turn a laser ray should hit an obstacle, is reflected diffusely by it (point S_{ij}) and returns to mirror in SA. At the moment when three objects - the point of reflection S_{ij} , the perpendicular to mirror and the vertical axis of SA - takes their common plane, perpendicular to plane XOY while SA is rotating, an optical signal, having travelled a path " S_{ij} - mirror M - objective O - optical channel OC - photoreceiver PR ". It makes an electrical stop signal. A start signal is previously formed by SA by means of a zero-sensor (installed on a bar b axis) (Rivas et al., 2008).

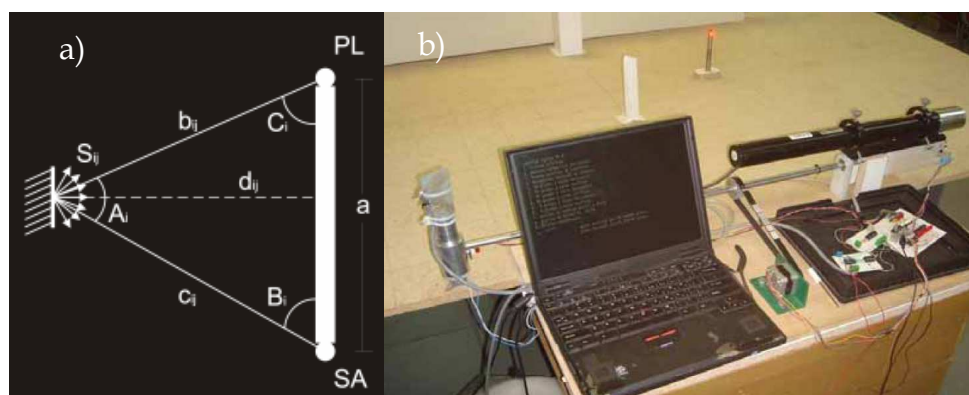

Fig. 10. a) Triangulation scheme, b) Dynamic triangulation scanner

The principle of this system is promising, although it has multiples disadvantages when the system is actually developed and running. The usage of the timing belts for the angular rotation of the system is one of them. Moreover, the system must undergo a thoroughly calibration to guarantee that the mirror rotates parallel to the system, and the receptor motor is not sufficient to guarantee constant rotational speed. Lastly, there are some components that vibrate and generate unwanted noise.

4.2.4 3D Rotational Body Scanner

The Rotational Body Scanner uses the principals of Dynamic Triangulation Scanner. (Basaca & Rodriguez, 2010). Increases its precision, decreases the mechanic noise sources and makes the addition of a stationary rotation system independent of timing belts (Rivas et al.,2008). The system receptor (see Figure 11) consist of 5 main components A) 45 degree rotational mirror, whose principal function is to direct the laser light beam towards the lenses (targets). B) Targets, whose function is to concentrate the light beam onto photodetector. C) DC Motor, which rotates the mirror. D) Photodetector, it captures the light beam located within the frequency range of the laser. E) Flat Bearing, allows the rotation in the angular axis of the system.

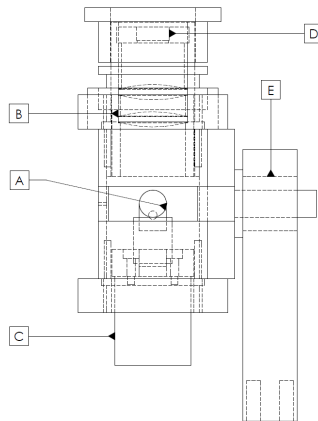

Fig. 11. System receptor

The system projector has 5 main components (see figure 12), which are the following: 1) Step Motor of angular rotation, whose main function is to control the rotation of the entire system. 2) Step motor for the mirror rotation, which controls the mirror rotation. 3) System's rotation gear, increases the precision of the system since it gives a 10:1 ratio gear-motor. 4) Mirror's rotation gear increases the precision of the system giving a 10:1 ratio gear. 5) Mirror, reflects the laser light beam towards the scanning body.

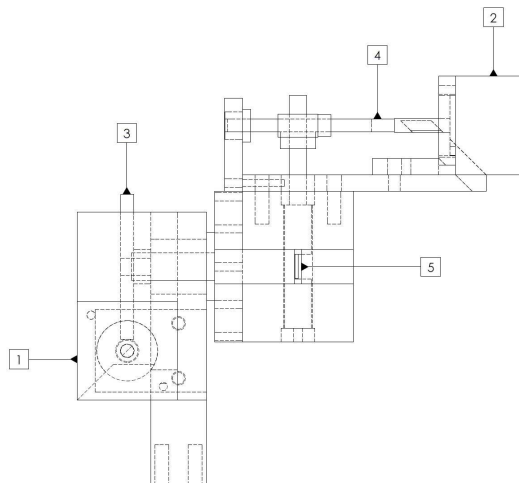

Fig. 12. System projector

The laser light projector emits the light at different angles towards the body. And at the same time the receptor rotates until it detects the light deflected by the body. When the mirror of the receptor deflects the scattered light towards the target and concentrates the light towards the photodetector, an electronic pulse is emitted which indicates the point has been detected. A relationship between the rotation time and detection time shows the angle

in which the receptor detects the point. Since the projector rotation is controlled by the user, the angle of the projector is known at all times. The relationship between the 2 angles and the known distance between the projector and receptor gives each of the captured coordinates.

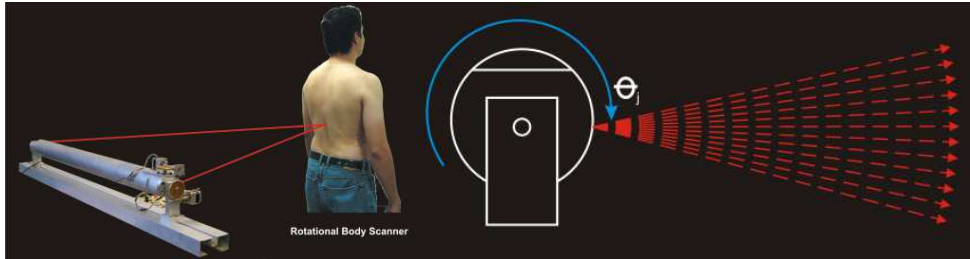

Fig. 13. 3D Rotational Body Scanner

As shown in figure 13, the projector and receptor are separated by a bar that gives the exact distance of 1 meter between them, and located in the bar is the laser light source. Within the bar the laser also gets aligned and locked avoiding measurement errors. The triangulation principle used is well known, and some of the advantages given by this system is the angular rotational mechanism (see figure 13) which allows the rotation with no chains, an increment in resolution of 10 times by using gears that gives 1 rotation for each 10 rotations that gives the step motor, inaccuracy caused by friction are decreased by using polytetraflourtethylene flat bearings which has the lowest friction coefficient of all materials, and the fabrication cost is economic.

4.3 Traceable 3D laser imaging metrology

The statement of uncertainty is based on comparisons with standards traceable to the national units (SI units) as requested by ISO 9000-9004. For example, manufacturers of theodolites and CMM manufacturers use specific standards to assess their measuring instruments. A guideline called VDI/VDE 2634 has been prepared in Germany for close range optical 3D vision systems. It contains acceptance testing and monitoring procedures useful for practical purposes for evaluating the accuracy of optical 3D measuring systems based on area scanning - bundle of rays. These systems work according to the principle of triangulation, e.g. fringe projection, Moiré techniques and photogrammetric/scanning systems based on area scanning (Beraldin et al., 2007). According to National Institute of Standards and Technology (NIST) in the Proceedings of the LADAR Calibration Facility Workshop, Gaithersburg, June 12 - 13, 2003 the steps to perform a 3D laser scanning calibration could be the following.

Calibration of the direction component: Using theodolite-type scanners, the direction affecting instrumental errors of the laser-scanner could be calibrated by procedures known from theodolites These are:

1. Vertical axis wobble, which acts as a lever effect, if the scanner does not correct this influence by inclination sensors.
2. Eccentricity of scan center.
3. Collimation axis error.
4. Horizontal axis error.

However no internationally recognized standard or certification method exists; the evaluation of the accuracy, resolution, repeatability or measurement uncertainty of a 3D imaging system still remains the responsibility of the user.

5. Conclusions

Not all scanning methods are as accurate as the diverse applications demands. None of the systems is superior in every area of applications.

The MillimeterWave based systems are sufficient for object detection but underdeveloped to be used in the medical environment where accuracy is needed. The main disadvantage of these systems is that their accuracy and contrast are sacrificed to be able to perform real time scanning.

The diverse techniques used in Photogrammetry are appropriate to perform the modeling representation of the scanned objects, although not all techniques have the capability to perform measurements, such as the White Light Scanner by 3D3 Solutions mentioned above. This is one of the main reasons why the laser scanner based systems are preferred when measurements and surface areas are needed to be known, due to their attributes such as accuracy and efficiency.

If one of the system requirements to be met is that the 3D Model can be digitally rotated to offer its view in different angles, multiple laser scanner based systems can be used simultaneously. The speed of the laser scanning will be proportional to the number of systems used, since the simultaneously measurements of the multiple systems do not interfere between them. This laser scanning system attribute differs with the Photogrammetry based systems since they cannot perform the scan operation simultaneously due to the light projections interference, such as Formetric 3D/4D, which makes the speed ratio inversely proportional.

The 3D Rotational Body Scanner increases by 10 times its resolution in comparison with the former 3D Triangulation method. This is possible by using gears that gives 1 rotation per each 10 that gives the step motor. The increase in accuracy given by this improved method can be potentially used in other applications, for example, the scan of small parts of the human body, such as fingers and teeth.

Moreover, the 3D Rotational Body Scanner decreases significantly the mechanical sources of noise, and guarantee less calibration since is a more stable than the former 3D Dynamic Triangulation scanner.

The combination of the photogrammetry method and the 3D dynamic triangulation method could be an interesting area of opportunity. The image modeling phase could be obtained through the photogrammetry techniques and the accuracy and dimensional measurements could be complemented by the improved 3D Rotational Body Scanner system, although this is yet to be explored.

6. References

- Azernikov, S.; Fischer, A. (2008). Emerging non-contact 3D measurement technologies for shape retrieval and processing, *Virtual and Physical Prototyping*, Vol. 3, No. 2 (June 2008) pp 85-91, ISSN: 1745-2759.
- Básaca, Luis C.; Rodríguez, Julio C.; Sergiyenko, Oleg.; Tyrsa, Vera V; Hernández, Wilmar.; Nieto Hipólito, Juan I; Starostenko, Oleg. 3D Laser Scanning Vision System for

- Autonomous Robot Navigation, *Proceedings of IEEE (ISIE-2010)*, Bari, Italy, July 4-7, 2010, pp.1773-1779, ISBN 978-1-4244-6390-9.
- Beraldin, J.A.; Rioux, M.; Cournoyer, L.; Blais, F.; Picard, M.; Pekelsky, J (2007). Traceable 3D Imaging Metrology, *Proc. SPIE 6491*, ISBN: 9780819466044, California, USA, January 2007, SPIE, San Jose.
- Beraldin, J.A. (2004) Integration of Laser Scanning and Close-range Photogrammetry the Last Decade and Beyond, *ISPRS Journal of Photogrammetry and Remote Sensing*, Volume XXXV, No. B5 (July 2004) pp. 972-983, ISSN: 1682-1750.
- Bjarnason, J. E.; Chan, T. L. J.; Lee, A. W. M.; Celis, M. A.; Brown, E. R. (2004) Millimeter-wave, terahertz, and mid-infrared transmission through common clothing, *Applied Physics Letters*, Vol. 85, No. 4, (June 2004) pp. 519 -521, ISSN: 0003-6951.
- Boehnen, C.; Flynn, P. (2005) Accuracy of 3D Scanning Technologies in a Face Scanning Scenario, *Proceedings of 3-D Digital Imaging and Modelling*, pp 310-317, ISBN: 0-7695-2327-7, Ontario Canada, June 2005, IEEE, Ottawa.
- Calva, D.; Calva, S.; Landa, A.; Rudolph, H.; Lehman1, M. (2009). Face recognition system using fringe projection and moiré: characterization with fractal parameters, *IJCSNS*, Vol.9, No.7, (July 2009) pp 78 - 84, ISSN: 1738-7906.
- Creath, K.; Wyant, J. C. (1992). Moiré and Fringe Projection Techniques, *Optical Shop Testing*, Editor: Daniel Malacara pp. 653 - 685, John Wiley & Sons, ISBN: 0-471-52232-5, New York.
- Di, W.; Naiguang, L (2008). A pre-processing method for the fringe image in phase measuring profilometry, *Proc. SPIE*, Vol. 6623, No. 66231A, (March 2008) pp 1 - 8, ISSN: 0277-786X.
- Emmanuel P. Baltasvias (1999). A comparison between photogrammetry and laser scanning. *ISPRS Journal of Photogrammetry and Remote Sensing*, Vol. 54, No. 2-3, (March 1999) pp. 83 - 94, ISSN: 0924-2716.
- Haworth, C.D.; De Saint-Pern, Y.; Clark, D.; Trucco, E.; Petillot, Y.R. (2006). Detection and Tracking of Multiple Metallic Objects in Millimetre-Wave Images, *International Journal of Computer Vision*, Vol. 71, No. 2, (June 2006) pp 183-196, ISSN: 0920-5691
- Hierholzer, E. Drerup, B. (1995). High-resolution rasterstereography. *Three-Dimensional Analysis of Spinal Deformities*, Editors: Amico, D' M. Merolli, A. Santambrogio, G.C. pp. 435 - 439, The Netherlands: IOS Press, ISBN: 90-5199-181-9, Amsterdam.
- Howald, R.L.; Clark, G.; Hubert, J. Ammar, D. (2007), Millimeter Waves: The Evolving Scene, *Technologies for Homeland Security IEEE Conference on HST*, pp.234-239, ISBN: 1-4244-1053-5, Massachusetts USA, June 2007, IEEE, Woburn.
- Leifer, J. (2003) A close-range photogrammetry laboratory activity for mechanical engineering undergraduates, *Frontiers in Education*, 2003. FIE 2003. 33rd Annual, Vol 2, No F2E, (November 2003) pp 7 - 12, ISSN: 0190-5848.
- Lerch, T.; MacGillivray, M.; Domina, T. (2007). 3D Laser Scanning: A Model of multidisciplinary research, *Journal of Textil and Apparel, Technology and Management*, Vol. 5, No. 4 (October 2007) pp 1-21, ISSN: 1533-0915.
- Lippold, C.; Danesh, G.; Hoppe, G.; Drerup, B.; Hackenberg, L. (2007). Trunk Inclination, Pelvic Tilt and Pelvic Rotation in Relation to the Craniofacial Morphology in Adults, *Angle Orthodontist*, Vol. 77, No 1, (January 2007) pp 29 - 35, ISSN: 0003-3219.

- Liu, H.B.; Zhong, H.; Karpowicz, N.; Chen, Y. (2007) Terahertz Spectroscopy and Imaging for Defence and Security Applications, *Proceedings of the IEEE*, Vol. 95, No. 8, (October 2007) pp.1514-1527, ISSN: 0018-9219.
- Rivas Lopez, M.; Sergiyenko, O. & Tyrsa, V. (2008). Machine vision: approaches and limitations, In: *Computer vision*, Xiong Zhihui, (Ed.), pp. 395-428. Editorial: INTECH, ISBN 978-953-7619-21-3, Vienna, Austria.
- Rusinkiewicz, S.; Hall-Holt, O.; Levoy, M. (2002). Real-time 3D model acquisition. *ACM Transactions on Graphics (TOG)*, Vol. 21, No. 3, (July 2002) pp. 438 - 446, ISSN: 0730-0301.
- Sergiyenko, O.; Hernandez, W.; Tyrsa, V.; Devia Cruz, L.; Starostenko, O. & Pena-Cabrera, M. (2009). Remote Sensor for Spatial Measurements by Using Optical Scanning, *Sensors*, 9(7), July, 2009, MDPI, Basel, Switzerland, pp. 5477-5492. ISSN 1424-8220.
- Treleaven, B.; Wells, J. (2007). 3D Body Scanning and Healthcare Applications. *Computer*, Vol. 40, No. 7, (August 2007) pp. 28 - 34, ISSN : 0018-9162.

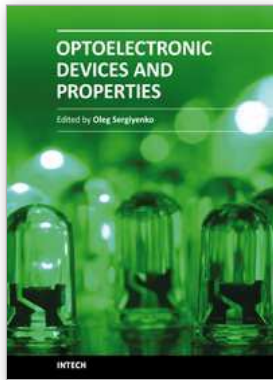

Optoelectronic Devices and Properties

Edited by Prof. Oleg Sergiyenko

ISBN 978-953-307-204-3

Hard cover, 660 pages

Publisher InTech

Published online 19, April, 2011

Published in print edition April, 2011

Optoelectronic devices impact many areas of society, from simple household appliances and multimedia systems to communications, computing, spatial scanning, optical monitoring, 3D measurements and medical instruments. This is the most complete book about optoelectromechanic systems and semiconductor optoelectronic devices; it provides an accessible, well-organized overview of optoelectronic devices and properties that emphasizes basic principles.

How to reference

In order to correctly reference this scholarly work, feel free to copy and paste the following:

Julio C. Rodríguez-Quiñonez, Oleg Sergiyenko, Vera Tyrsa, Luís C. Básaca-Preciado, Moisés Rivas-Lopez, Daniel Hernández-Balbuena and Mario Peña-Cabrera (2011). 3D Body & Medical Scanners' Technologies: Methodology and Spatial Discriminations, Optoelectronic Devices and Properties, Prof. Oleg Sergiyenko (Ed.), ISBN: 978-953-307-204-3, InTech, Available from: <http://www.intechopen.com/books/optoelectronic-devices-and-properties/3d-body-medical-scanners-technologies-methodology-and-spatial-discriminations>

INTECH

open science | open minds

InTech Europe

University Campus STeP Ri
Slavka Krautzeka 83/A
51000 Rijeka, Croatia
Phone: +385 (51) 770 447
Fax: +385 (51) 686 166
www.intechopen.com

InTech China

Unit 405, Office Block, Hotel Equatorial Shanghai
No.65, Yan An Road (West), Shanghai, 200040, China
中国上海市延安西路65号上海国际贵都大饭店办公楼405单元
Phone: +86-21-62489820
Fax: +86-21-62489821

© 2011 The Author(s). Licensee IntechOpen. This chapter is distributed under the terms of the [Creative Commons Attribution-NonCommercial-ShareAlike-3.0 License](#), which permits use, distribution and reproduction for non-commercial purposes, provided the original is properly cited and derivative works building on this content are distributed under the same license.