

A TD-LTE Prototype System with Modules for General-Purpose Cognitive Resource Management and Radio-Environmental Mapping

Tao Cai · Jaap van de Beek · Jad Nasreddine ·
Marina Petrova · Petri Mähönen

Received: 5 February 2011 / Accepted: 14 June 2011 / Published online: 28 June 2011
© Springer Science+Business Media, LLC 2011

Abstract In this article we describe a demonstrator that shows how the cognitive resource manager (CRM) and the radio-environmental map (REM) can be efficiently implemented in full commercial grade cellular system (i.e., LTE system). The demonstrator shows how the modular CRM together with its open interface, the universal link-layer API (ULLA), facilitates the implementation of efficient radio resource management techniques guaranteeing the quality of service in the LTE system. The CRM, through ULLA, is able to obtain PHY/MAC status information of the link between the tested eNode B and the user equipment, and reconfigure link parameters. This measure-and-control by CRM/ULLA is independent of the underlying radio access technology, which shows the neutrality of CRM/ULLA towards PHY/MAC characteristics. The article also shows how the REM can be easily implemented in such system and how the REM provides the CRM with environmental information that enhances system management performance.

Keywords Cognitive resource manager · Open interfaces · Radio environmental map · LTE · Prototype

1 Introduction

Many radio access technologies and their associated radio resource management (RRM) algorithms are developed and deployed in order to cope with the fast-increasing demand for mobile wideband services. Effective control over the radio resources is one of the most challenging design targets especially because radio resources, in the form of e.g., time slot resources and frequency spectrum resources, are limited and the wireless environment appears hostile with many impacting factors being rapidly changing and unpredictable.

Traditionally, RRM approaches cope with this increase in the demand on service and the involvement of different technologies by systematically adding more codes to RRM functionality, leading to a monolithic deployment. This makes RRM modules complex and difficult to understand, maintain and extend. Therefore, there is a need for new RRM architectures offering flexibility to suit advances in technologies and services demand but keeping the system complexity at relatively low levels with sustainable cost of development and ownership.

A second challenge in the design of efficient RRM approaches is the interdependency of different OSI stack layers that requires the existence of appropriate cross-layer optimization mechanisms to accomplish better performance. Thirdly, the presence of different access technologies with multiple interfaces requires the deployment of different RRM modules in the same equipment or even the use of different equipments. Hence, proper RRM architectures should accommodate integrated cross-layer

T. Cai · J. van de Beek
Huawei Technologies, Skalholtsgatan 11, Stockholm, Sweden
e-mail: tao.cai@huawei.com

J. van de Beek
e-mail: jaap.vandebeek@huawei.com

J. Nasreddine (✉) · M. Petrova · P. Mähönen
Institute for Networked Systems, RWTH Aachen University,
Kackertstrasse 9, 52072 Aachen, Germany
e-mail: jad@inets.rwth-aachen.de

M. Petrova
e-mail: mpe@inets.rwth-aachen.de

P. Mähönen
e-mail: pma@inets.rwth-aachen.de

optimization modules that can communicate with the external environment and modules of other equipments using unified interfaces to share information and decisions.

Modular architectures based on cognitive radio (CR) concept [1] may provide a solution for these design challenges. However, much of the recent research on CR has been focusing on dynamic spectrum access (DSA) and the few exceptions that considered the general CR concept in a wider perspective produced little progress on practical implementations [2–6]. Moreover many recently proposed conceptual CR architectures focus on new, clean-stable radio systems with only marginal interest in the possibility to apply CR and software-defined radio (SDR) principles [7] to *existing* high-value systems such as today's cellular systems.

A fourth and final challenge we address for the design of an efficient RRM architecture, is related to the underlying data used by the RRM modules and how radio environmental information (reflecting, for example, the amount of radio resources as well as the characteristics of interference) can be properly gathered and exploited by the CRM. Recent developments point in the direction of utilizing sensor-networks in collecting data that reflect the state of the radio environment and straightforwardly assist the CRM.

In this article we present a prototype system that reflects the above aspects through three key components. As a first component, in the heart of the prototype system, a cognitive resource manager (CRM) in the spirit of Mitola's CR concept, enables an easy implementation of complex control, cross-layer optimization and learning mechanisms. As a second component, a radio-environmental map (REM) provides the essential and necessary radio environmental information on which the CRM operates [8]. Finally, a prototype TD-LTE base station and user equipment (UE) provide the third system component: a radio transceiver whose transmission characteristics are controlled by the CRM. The CRM module has been developed and implemented within the framework of the ARAGORN project [9–11], the REM component is developed and implemented within the framework of the FARAMIR project [12], and the TD-LTE transceiver system has been developed by Huawei Technologies Co., Ltd.

The important innovations reflected in this prototype are the following. Compared to traditional RRM architectures the CRM exhibits the concept of modularity, run-time re-configurability, open interfaces and open policy languages. The CRM framework enables the CR to be aware of its environment and be able to configure its system parameters based on knowledge provided through a state-of-the-art sensing and mapping REM module. Finally, this concept is applied, implemented and evaluated in one of today's most rapidly growing cellular systems, an LTE system.

The article proceeds as follows. In Sect. 2 we describe the main conceptual architecture and the envisaged purpose, functionality and interaction of the three system components. Section 3 sketches the details of the particular prototyping characteristics and in Sect. 4 we present the results of our evaluation. In Sect. 5 we summarize and conclude this article.

2 System Description

Figure 1 illustrates the system architecture we study in this article (a more detailed description can be found in [11]). It includes the CRM core with its set of toolboxes, libraries, its open interfaces and its policy management layer. It also includes the REM module consisting of a large number of distributed sensor measurements inputs, an intelligent processing unit and a storage unit. The REM processing unit is responsible of defining measurement requirements and handling collected measurement results. Finally, there is the actual radio transceiver unit whose behavior is controlled by the CRM.

2.1 The CRM Core Module

The CRM core is a software entity that acts as the heart of the system. It facilitates the construction and management of the components that provide optimization control loops, and their interaction with the environment and the communication stack. The toolboxes and libraries provide a set of algorithms, components and tools that are used by system programmers, and also used by the CRM to optimize the use of the radio resources in real time.

Three external inputs provide the necessary information for CRM decisions. First, the REM provides input from the physical nature of the radio environment. Second, the rules and policies set by different stakeholders are provided and managed by the policy layer that resolves any conflict between them. Policies can be regulatory in nature, such as spectrum use rules, but also provide user preferences, device manufacturer configurations, or operator specific policies.

In addition to these external inputs, the CRM can access the information of the different layers of the OSI stack using open interfaces. These interfaces provide also the means to control configurable parameters of the different layers. This interaction between the CRM and the OSI stack facilitates the implementation of cross-layer optimization and learning techniques. The open interfaces are the universal link-layer API (ULLA), used for interaction with the link/physical layer, the generic network interface (GENI), used for interaction with the transport/network layer, and the common application requirement interface (CAPRI) for imposing application layer requirements.

Fig. 1 High level architecture of CRM framework together with the REM

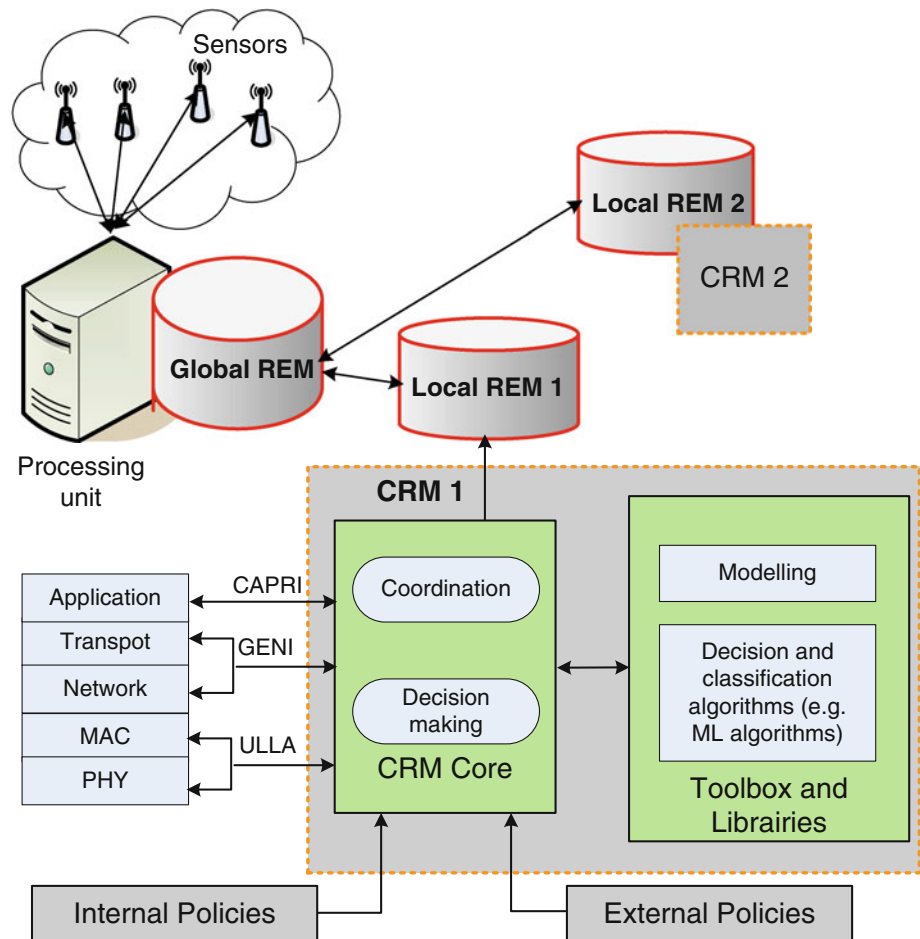

ULLA was originally developed in the GOLLUM project [13, 14] and extended by ARAGORN [15] to demonstrate the possibility of using single generic interface to extract information from and control various PHY/MAC layer technologies, and to enable cross-layer optimization in heterogeneous systems independently of the used radio access technology. It also supports spectrum sensing mechanisms and policy handling. One of the key benefits from a practical industrial point-of-view is that ULLA enables a massive reuse of code base, as one does not rewrite all the code for changing air interfaces. Moreover, ULLA supports flexible data and control hiding, i.e., some of the parameters can be opened for third-parties or sub-contractors, but others can be hidden.

Due to the presence of the open interfaces, the CRM can be implemented independently of the used radio access technology in the network. This gives the CRM a high flexibility and enables the developer to implement the same algorithms for different technology platforms. CRM concept has been earlier tested and partially implemented as research prototype especially for ISM-band devices [16]. However, in this article we report on the first

implementation prototype that is done for a full commercial-grade cellular system, where there are strict legacy technology rules. We will specifically explore and report our experience on using CRM/ULLA to partially overtake the role of the RRM and control the PHY/MAC layers of the evolved universal terrestrial radio access (E-UTRA).

A final important feature of the CRM architecture is to separate machine-learning and optimization modules from kernel components of the controller. This does not only provide increased modularity but also enables easier integration with legacy systems through well-defined interfaces. Moreover, the generality of the cognitive architecture prevents the CRM from being too closed or too prototype-oriented.

2.2 The REM Module

Another key component in the prototype system is the REM module that deals with the collection of measurements and transformation of measurement results into a map that represents the state of the radio environment. Typically such a REM is a geographical map of the radio

field strength in different positions. This map will naturally change from one time to another as the radio environment is seldom static in nature.

Input data are collected by a network of distributed sensors. The received power at the sensors' locations along with a time stamp and a location stamp are uploaded to a central network node where sensor measurements are stored in a global REM and then processed. Processing of the sensor data in an intelligent module attached to the storage, serves the purpose of estimating the field strength in positions other than the sensor positions and hence to create a map that enhances the performance of the CRM. In the proposed architecture each CRM will be connected to a local REM where the required data are pulled from the global REM. A local REM will also contain data which are collected and used locally. In practice, a sensor can be a stand-alone entity that provides power/location measurements, or it can be an add-on measurement module (e.g., TV band measurement module) embedded into LTE terminals. In fact, actual LTE terminals have the capability to make different types of measurement such as intra/inter frequency and inter-RAT mobility measurements that are required for the REM. However, an add-on measurement module is needed in the case of TV white space measurement since this capability is still not foreseen in third generation partnership project (3GPP) release ten terminals.

The estimation of the field strength can be accomplished in one of two approaches. The first approach is based on direct signal processing algorithms that attempt to interpolate the sensor measurements in order to create a 2D map of the signal strength [17]. The second approach involves an intermediate step, where the locations and the transmit power of any active unknown transmitters are estimated in a first processing step. A second step then involves the application of an appropriate radio path loss and propagation model in order to generate the REM from the set of transmitter location-power pairs [18].

In [19], the conceptual feasibility of generating such a REM was demonstrated, in a distributed sensor network consisting of 16 heterogeneous sensors with different capabilities. Algorithms for estimating the unknown location and power of a transmitter, along with proper radio propagation models allowed for the dynamic generation of radio field maps, only based on the power measurements at the sensors' locations.

2.3 The TD-LTE Platform Module

Within the 3GPP the specification of E-UTRA is currently ongoing [20, 21]. E-UTRA is the long term evolution (LTE) of the third generation radio access technology. Starting from years 2007 to 2008, LTE standardization has progressed from feasibility study to technical

specifications. 3GPP Release 8 is the first LTE release with features that are sufficiently stable now for commercial implementation, and commercial systems have been deployed in many countries. Meanwhile 3GPP has been progressing with LTE release 10 and release 11.

Compared with previous generations of wireless access technology, LTE is not only able to operate in different frequency bands but can also flexibly support different bandwidths, thereby allowing a flexible use of the assigned, or available, spectrum for different types of services. This is very important and beneficial capability in the perspective of spectrum usage. Depending on the regulatory aspects in different geographical regions, radio spectrum bands and their usage for services are mandated under various rules and policies, including major differences in the way of regulating frequency bands, bandwidths, duplexing and interference constraints. The flexible spectrum capability of LTE can make it suitable access technology for both fixed spectrum allocation and dynamic spectrum sharing paradigms.

One unique feature of LTE is that different uplink (UL) and downlink (DL) bandwidths can be used in the same access network, allowing for asymmetric spectrum utilization. LTE network can support both paired frequency-division duplexing (FDD) standard mode (where UL and DL transmissions use separate frequency bands) and unpaired time-division duplexing (TDD) standard mode (where UL and DL transmissions share the same frequency band). The use of FDD in the network, to some extent, limits the flexibility needed to keep track of the changing traffic conditions and requirements: TDD operation is better suited for flexible spectrum.

One network deployment scenario where flexible spectrum use is beneficial is the single operator heterogeneous network deployment, where (public) macro cells share the same spectrum with many femtocells [22]. Femtocell deployments are normally massive, uncoordinated and dynamic, which very often lead to interference-limited network and therefore necessitate flexible allocation of the spectrum resource and constant optimization thereof. Spectrum is dynamically reused to balance between femtocells' and macrocells' loads. Furthermore, TDD operation is again better suited for the heavy data traffic that appears in femtocell deployments.

In another type of network deployment scenario, different radio access technologies might need to be able to operate jointly in the same overall spectrum. Spectrum flexibility from LTE technology, and especially LTE TDD operation, can make LTE access a suitable component part of such coexisting network composition.

Moreover, LTE is readily capable of using new possibilities provided by CR and DSA principles, e.g., *TV White Space* and its utilization.

In order to coordinate spectrum resource management across different radio-access technologies (RATs) and within single operator single RAT heterogeneous network deployment, the technology-platform neutral ULLA/CRM and the environment characterization tool (i.e., REM) are envisaged as the critical entities to enable efficient spectrum resource management. In this study we demonstrate that the combination of LTE and ULLA/CRM/REM modules is a promising approach for RRM and cross-layer optimization with limited overall system complexity.

3 Demonstrator Architecture

The architecture of ULLA/CRM implemented on LTE platform is illustrated with the physical nodes and their connections in Fig. 2.

The LTE system is built upon Huawei’s LTE TDD platform and comprises of one LTE TDD UE and one LTE TDD eNode B. More specifically, the following components form the demonstration architecture:

- LTE TDD UE is terminal equipment compliant with 3GPP release 8 specifications. It has all the components of user equipment except a user interface (the screen), which is implemented with a PC (PC1).
- LTE TDD eNode B is based on Huawei’s LTE platform with TDD functionalities [23, 24]. It has all the necessary functions which are needed to communicate with the LTE TDD UE. The LTE UE and eNodeB are shown in Fig. 3.



Fig. 3 LTE prototype equipment. Baseband unit (top), RF unit (bottom)

Fig. 2 Architecture of the LTE demonstration system

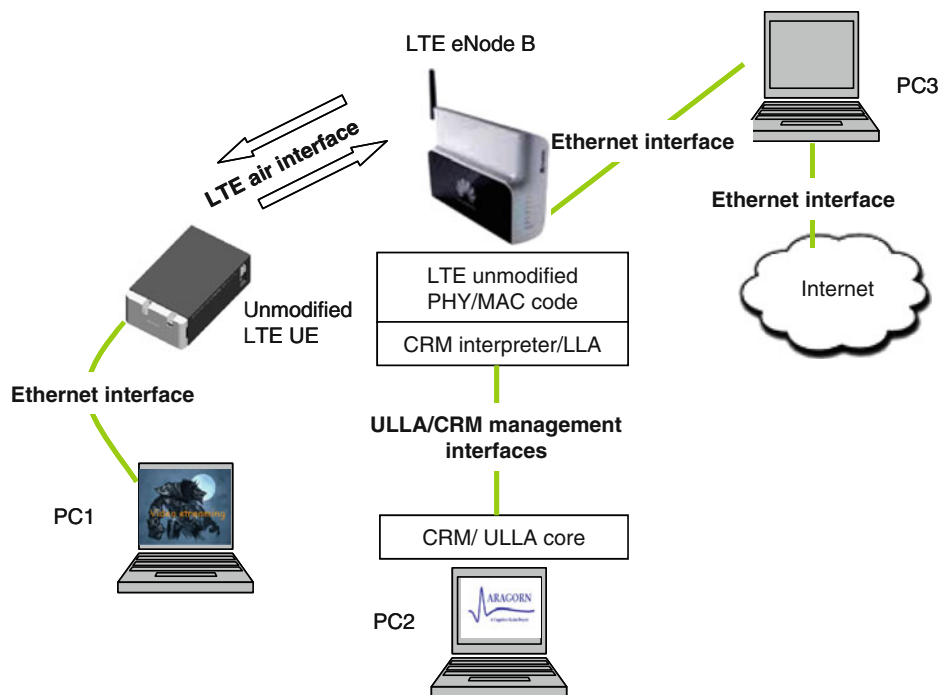

- PC1 is connected with UE through Ethernet link and is used as the user interface, e.g., for showing video stream applications and monitoring the performance characteristics. Meanwhile PC1 is able to present the link status between UE and eNode B. Link status information includes signal to interference noise ratio (SINR), block error rate (BLER), modulation and code scheme (MCS), buffer status, bandwidth usage, etc.
- PC2 is connected with eNode B through Ethernet link and it is based on Linux OS system. The resource management part, which is demonstrated in the article, is performed by ULLA/CRM that are running on PC2, instead of e.g., an eNode B scheduler. A link layer adapter (LLA) for LTE TDD is used to adapt between ULLA/CRM and LTE system.

- PC3 is used as application server; it is also connected to Internet.
- The REM function and its associated (off-the-shelf) SQL database are implemented in PC2, where the CRM resides. The CRM can thus utilize REM/SQL database directly without the need of a specific interface and data model.

In general, the CRM/ULLA does not need to be in separate computing platform. Naturally these functionalities could be embedded to products themselves. In our case, the implementation approach is not only practical but it also demonstrates some special values. First, by showing that CRM control entity can be implemented separately and can provide real-time control demonstrates that CRM can be built as a general management entity that can control several RATs through its interfaces. Second, our implementation shows that with very *minimal* extra components, and without changes to core parts of the product we can integrate CRM and ULLA also to finalized (legacy) systems. Third, we show with this approach that both functional and physical separation of key components is possible and does not generate extra software development burden.

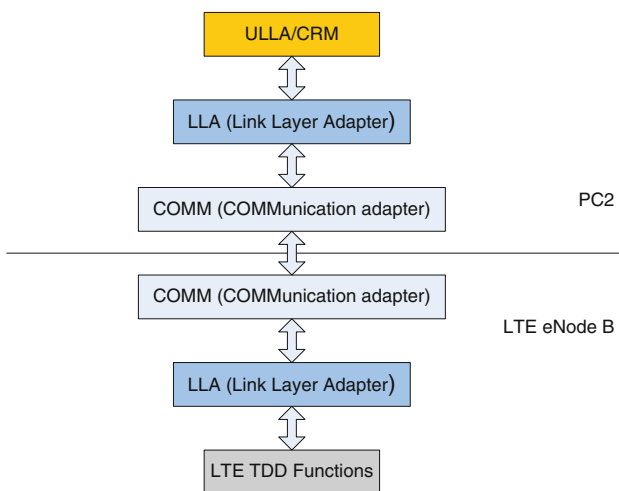
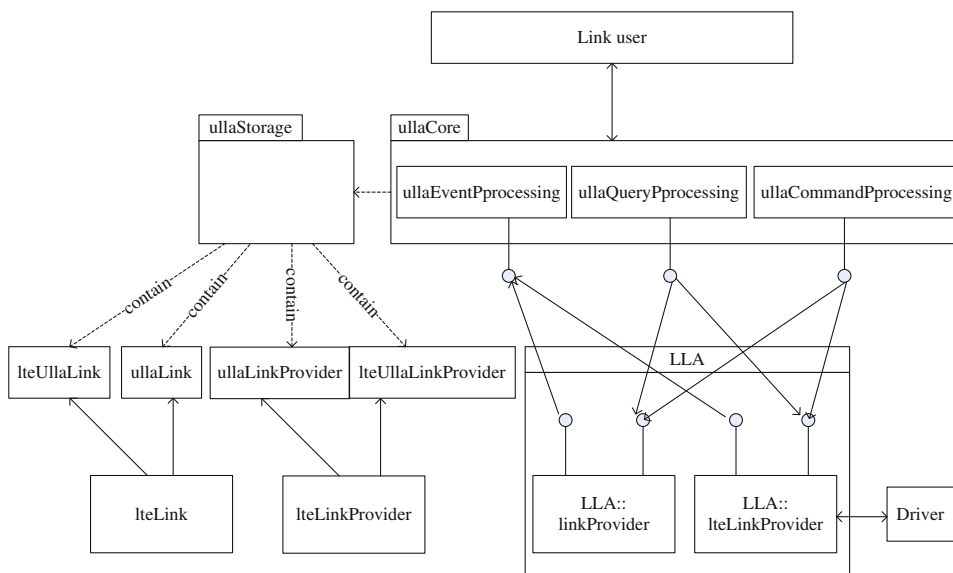

Fig. 4 Integration of ULLA/CRM and LTE TDD MAC/PHY

3.1 Interfaces

To integrate ULLA/CRM to the LTE system, there is need for a link layer adapter (LLA) to act as the interface between ULLA and LTE MAC/PHY layer as shown in Fig. 4.

Fig. 5 Data model of LTE LLA



- LLA is the interface between ULLA/CRM and LTE TDD MAC/PHY. It receives message from LTE MAC/PHY.

PHY layers and later modifies the parameters of the LTE TDD MAC/PHY layers according to the decision by CRM/ULLA, and in such way to control LTE TDD system.

- The COMM (COMMunication adapter) layer is a communication module which employs SOCKET communication protocols to exchange information between PC2 and LTE TDD eNode B. The COMM layer is used on the Ethernet link between PC2 and eNode B for the

specific implementation of this demonstration system. If the ULLA/CRM are integrated with LTE TDD in one single physical equipment, this communication will become internal function and a COMM interface is not needed.

- LLA in eNode B is an agent which translates the ULLA/CRM information into proper format which can be interpreted by LTE TDD functions in the eNode B.

Fig. 6 Attributes of LTE link and LTE link provider that are used in our prototype architecture

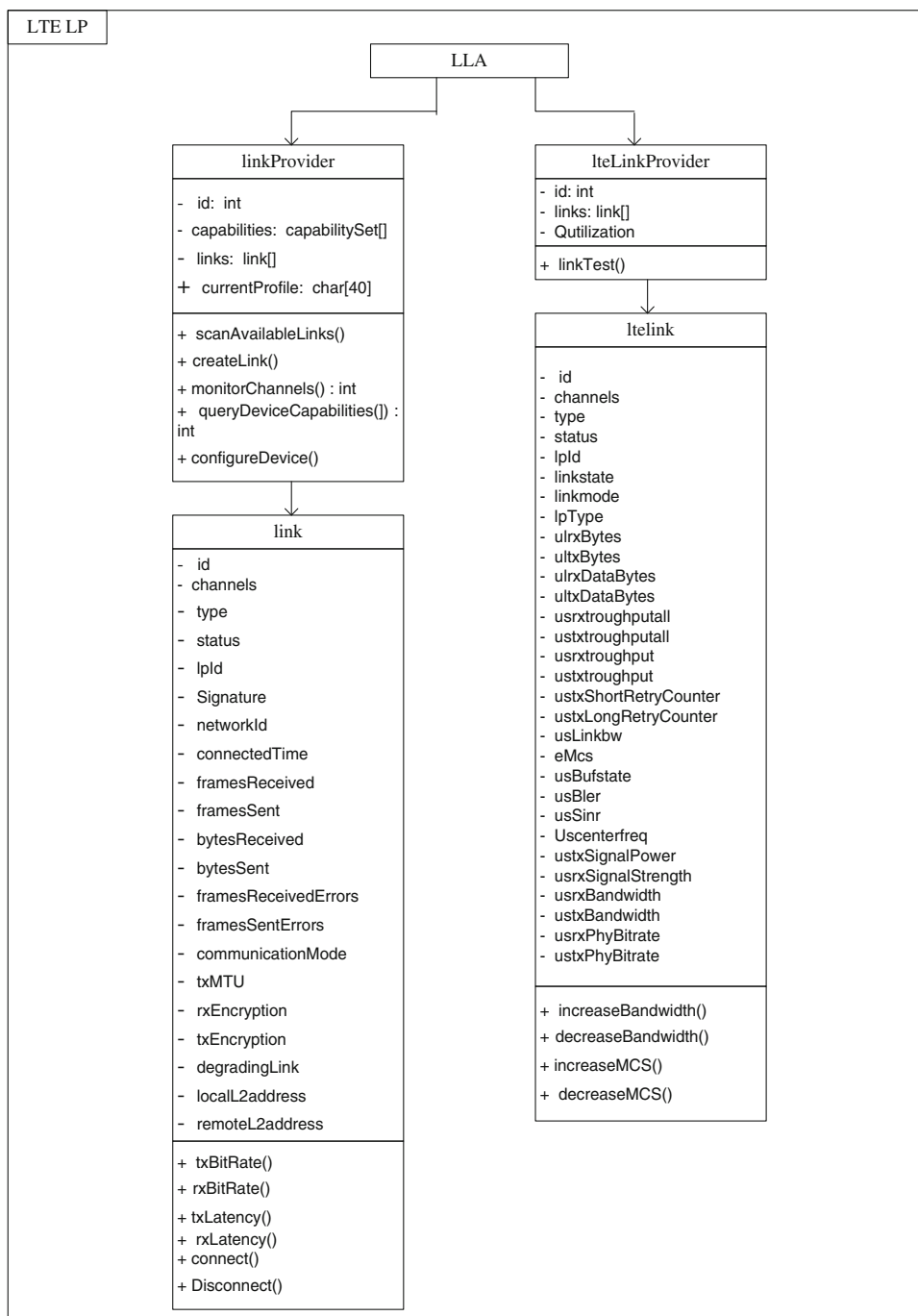

3.2 Data Model of System Status Information and Control Signalling

In the LTE-based implementation of the CRM, the devices' status information and corresponding control signaling are abstracted as data objects or classes. LTE LLA supports basic classes that are not technology-specific (e.g., link and link provider), as well as technology-specific classes (e.g., LTE link and LTE link provider). The architecture of data

model of LTE LLA is illustrated in Fig. 5. Detailed description on LLA link and link provider model can be found in [14].

The two link providers help the link user to get the low-layer information and to control the hardware and PHY layer. The link provider is the basic class and provides common link information while the LTE link provides LTE specific information, e.g., modulation coding scheme (MCS) and channel-quality indicator (CQI). The two link

Fig. 7 REM-generation module. Input screen entering the environment (*top*) and output screen illustrating the estimated location and no-talk region around an unknown interfering transmitter (*bottom*)

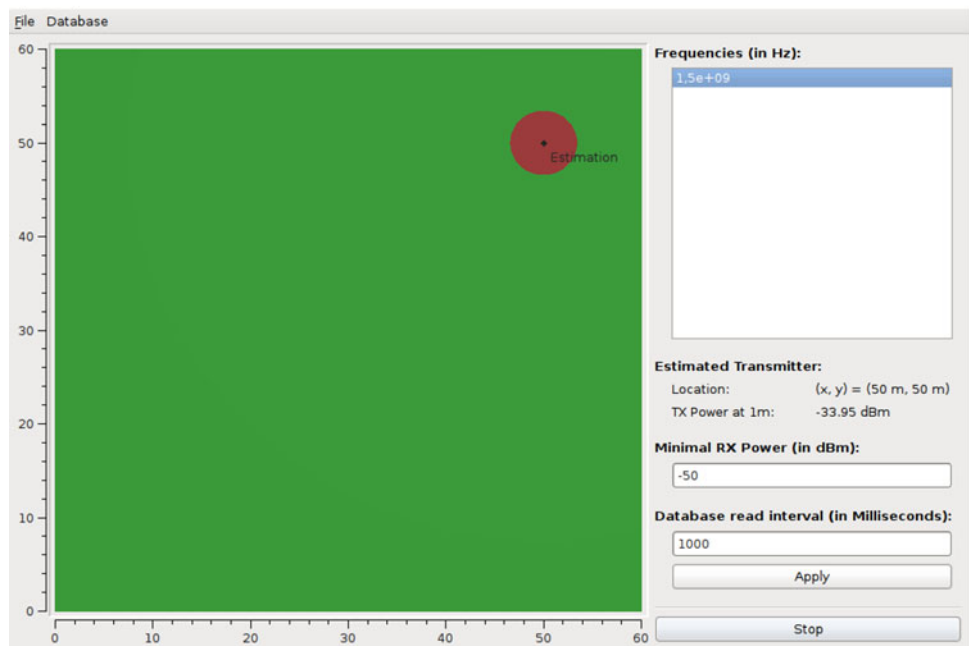
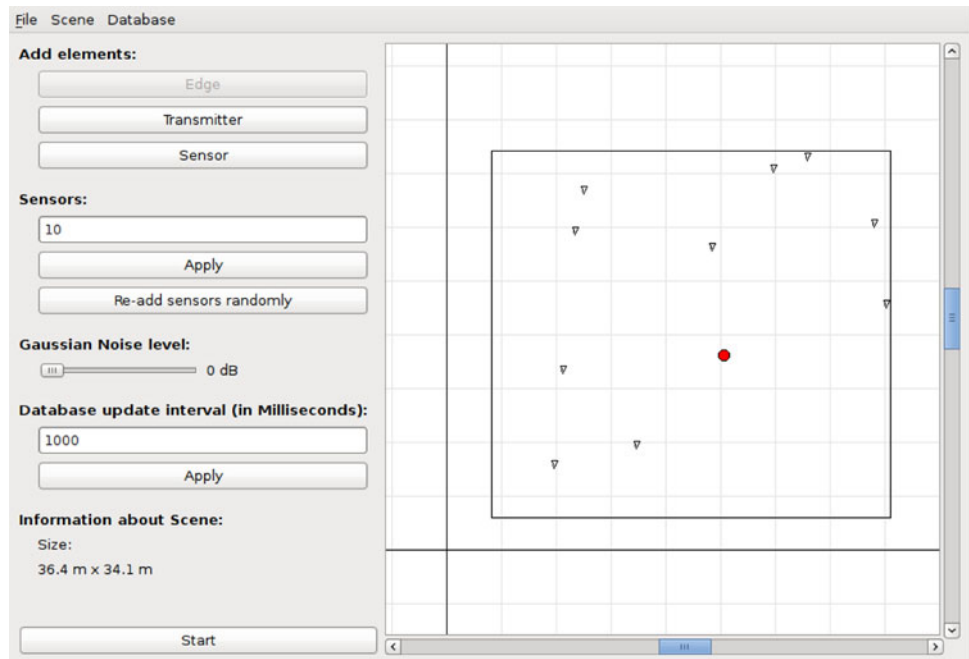

providers operate independently; the parameters in the link provider and LTE link provider are supported simultaneously in order to obtain the complete information from LTE system.

The driver (illustrated on the bottom right of Fig. 5) can be configured by both the link provider and LTE link provider that can also obtain hardware status information from the driver.

In the storage part of ULLA, ULLA link, status information of LTE ULLA link, ULLA link provider and LTE ULLA link provider will all be stored. For the LTE specific link and link provider, the detailed attributes of information model are illustrated in Fig. 6. Especially, in the LTE link provider, one function *linkTest* is defined and is used to test whether the link is ready or not. After *linkTest* is done, four functions can be used for the link control/reconfiguration: *increaseMCS*, *decreaseMCS*, *increasebandwidth* and *decreasebandwidth*.

4 Results

4.1 REM Generation

Figure 7 shows the results produced by the REM module and used by the CRM in the system. The top figure illustrates the graphical user interface of a sensor-emulating unit. Given the geographical positions of a (large) number of sensor units on an interactive map, along with the position and the transmit power of one or a few fictitious interfering transmitters, this unit writes emulated sensor measurements to an SQL database with regular time intervals. These measurements will form the basis of further intelligent processing in order to generate a relevant REM.

The bottom figure illustrates the user interface of the (independently running) software module that generates the actual REM. Based on the sensor measurements it reads from the SQL database, the location and power of unknown interfering transmitters are estimated. Then based on these estimates, the strength of the radio field is computed according to a relevant path-loss model. Depending on a user-indicated field-strength threshold a *no-talk* area is graphically indicated on the map, illustrating in which coordinates a cognitively operating TD-LTE transceiver is either not allowed to operate or will not be able to operate within reasonable quality of service (because of the interference from the apparent other transmitter will negatively impact SINR value on LTE link).

The information generated by this REM is then immediately exploited by the CRM module in the second part of our demonstration.

4.2 CRM Performance Evaluation

In the current demonstration system, the cognitive resource management is responsible of bandwidth assignment and MCS adaptation. Here the bandwidth refers to the number of LTE resources blocks (RBs) used by one LTE link. MCS is to be adapted according to channel quality. All the controls are done by CRM that jointly uses above functions to achieve efficient resource utilization.

The prototype of CRM/ULLA-enabled LTE is used for demonstration and system performance measurements, and to show that the system is fully functional. Our LTE platform has demonstrated following results:

- *System start-up*: When system starts, LLA will register the LTE TDD link and link provider to the ULLA/CRM. Then, ULLA/CRM will send to the LTE TDD eNode B query requests about the equipment, link and radio environment information Through LLA. The LTE TDD eNode B accepts the query request, measures the system status and reports the information queried back to ULLA/CRM. The latter will determine, according to pre-defined policies for resource usage, if there are link or equipment parameters that should be changed to achieve a better performance. Policy engine and repository [24] are in PC2 where the CRM is also running. The dynamic loading of the policies can be easily demonstrated. The optimization algorithms, which can be implemented in different manners, reside in CRM.
- *Bandwidth adaptation*: ULLA/CRM change the bandwidth according to service bit rate requirement. When a new service is added to an existing user of the LTE link in the system, more bandwidth is needed for this link. The bandwidth is increased in order to satisfy the QoS of the new service. On the other hand, when the assigned bandwidth exceeds the requirement for one link, e.g., when a service is terminated, the “surplus” bandwidth is to be released. In this demonstration, ULLA/CRM use traffic buffer size as indicator to detect if the bandwidth is sufficient or not. If the bandwidth assigned for the link matches the QoS requirement, there shall be neither overflow nor starvation. If overflow happens, it indicates that the bandwidth of the link needs to be increased. In starvation case, CRM will decrease the bandwidth of the link. In order to maintain efficient resource management, the CRM periodically queries the services and link status.
- *Link adaptation*: ULLA/CRM adapt the MCS according to link status, and changes the bandwidth as to maintain the service QoS: MCS adaptation in LTE is based on SINR of the active link. If the SINR is

sufficiently high, CRM will ask the link to adjust use higher order MCS (e.g., from 16QAM to 64QAM). With the adjustment of MCS, the service bit rate will be increased accordingly. At the same time, the bandwidth can be decreased if there are no enough traffic data to be transmitted. On the other hand, ULLA/CRM will decrease the MCS order when link quality is bad and will increase the bandwidth if the requirement on service throughput is still high.

In Figs. 8, 9, 10, 11, 12, 13, and 14, we show the demonstration user interface where CRM/ULLA can be seen tracing system status and change parameters. The service shown is a video streaming application. The status information collection and controlling signaling are shown below the video window. System status is shown with various parameters on the left (i.e., SINR, buffer status, bandwidth, modulation and throughput). These figures show how the CRM efficiently reacts to different changes by tuning the configurable parameters accordingly.

Our testing platform has shown that the CRM/ULLA modules are robust and provide real-time control capability towards LTE equipments. The link adaptation can be done in millisecond time-scale which is sufficient for all our current test scenarios.

The developed LTE LLA and CRM message interpreter in LTE equipment has required only limited amount of coding

time (few weeks) and code base is also small. In fact, the simplest way to implement LTE LLA and CRM command interpreter would require one or two thousands lines of code. In our LTE LLA/CRM interpreter, we have considered scalability and a future proof architecture, and therefore the lines of code increased to around four thousand. For reference, a commercial LTE resource management system requires effort at level of hundred thousand lines of code.

Currently, the experiments are on single LTE link where CRM makes mostly baseband adaptation based on REM input. In the future we will consider frequency (channel) change in DSA fashion as one of the optimization possibilities with multiple LTE links.

5 Conclusions

In this article, we have demonstrated that ULLA/CRM can provide efficient resource management for an LTE system. Due to their neutrality towards the PHY/MAC characteristics of LTE, the same CRM/ULLA can be also used for other access technologies and systems. This proves the capability of ULLA/CRM to manage resource utilization for different technology platforms.

The hybrid approach of our current coding is quite novel. CRM is responsible for handling high abstraction

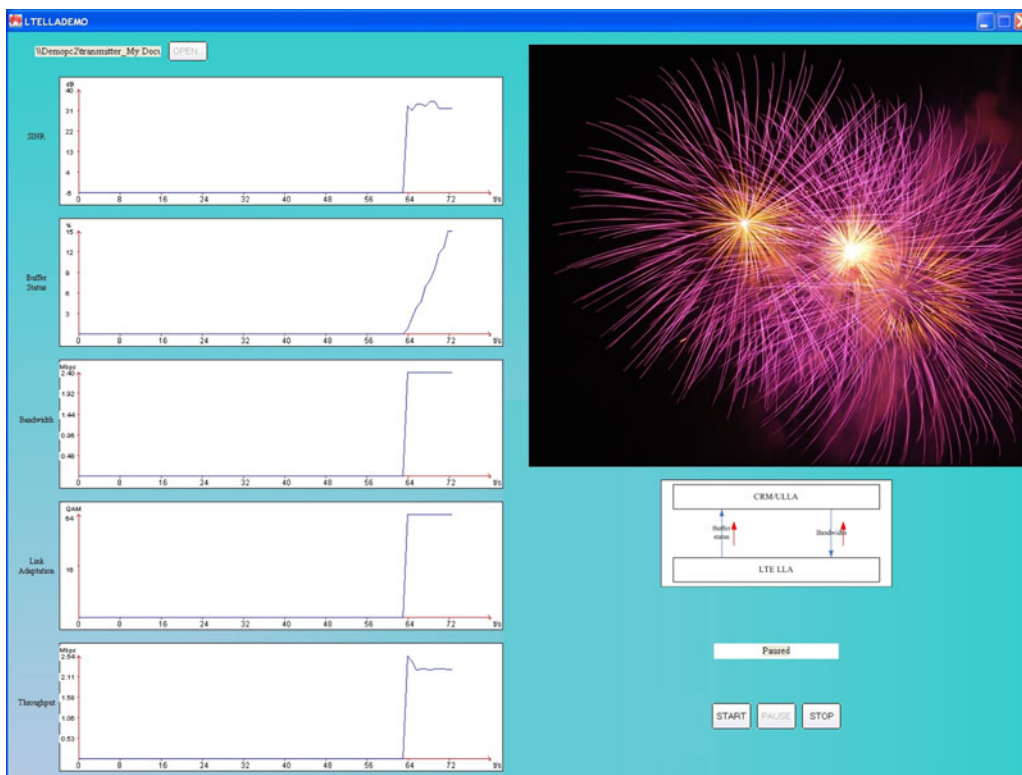

Fig. 8 The system starts, the initial bandwidth is insufficient and user data buffer is built up

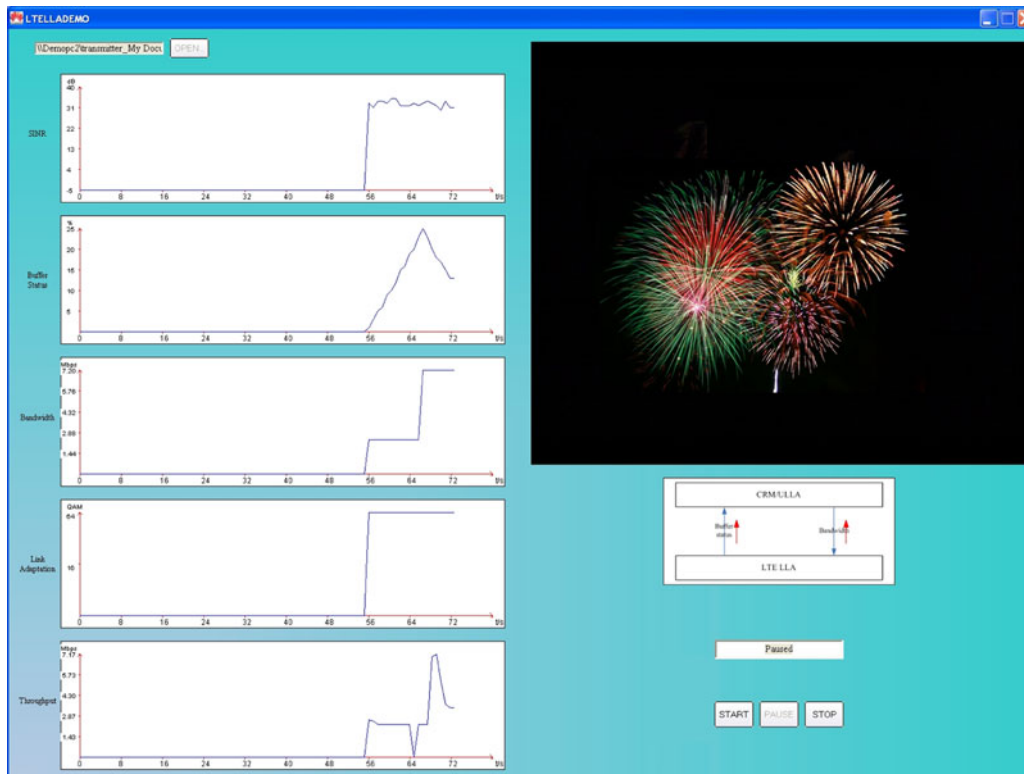

Fig. 9 CRM/ULLA allocates higher bandwidth and increases system throughput

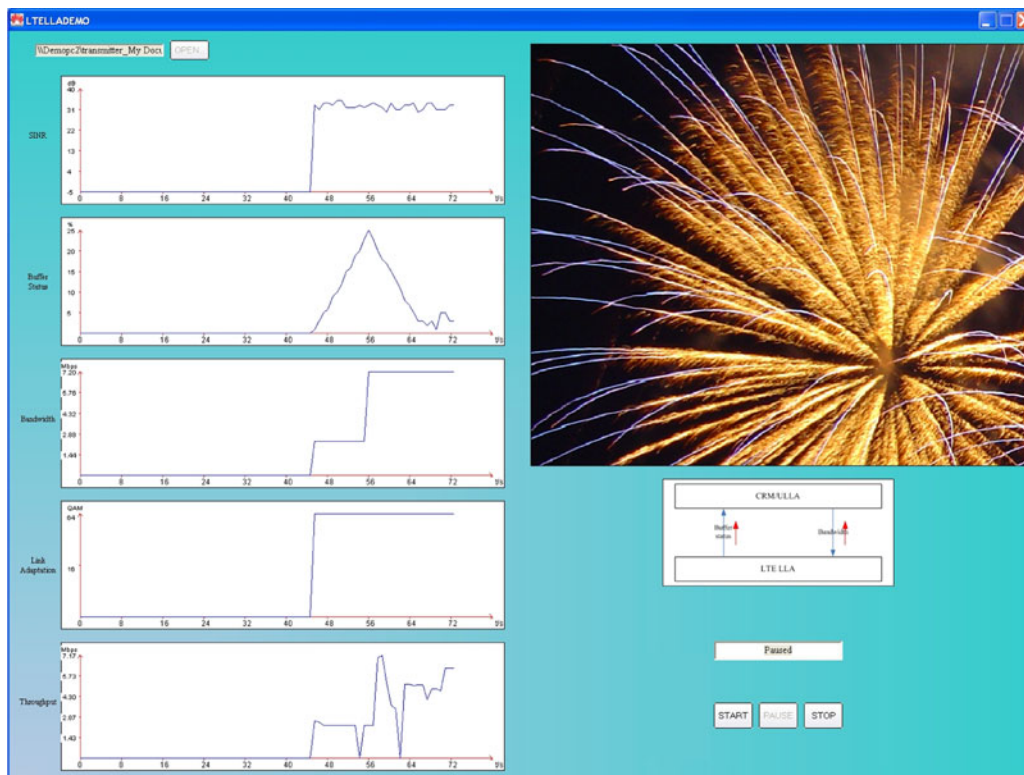

Fig. 10 Buffer overflow is avoided and buffer size is decreased

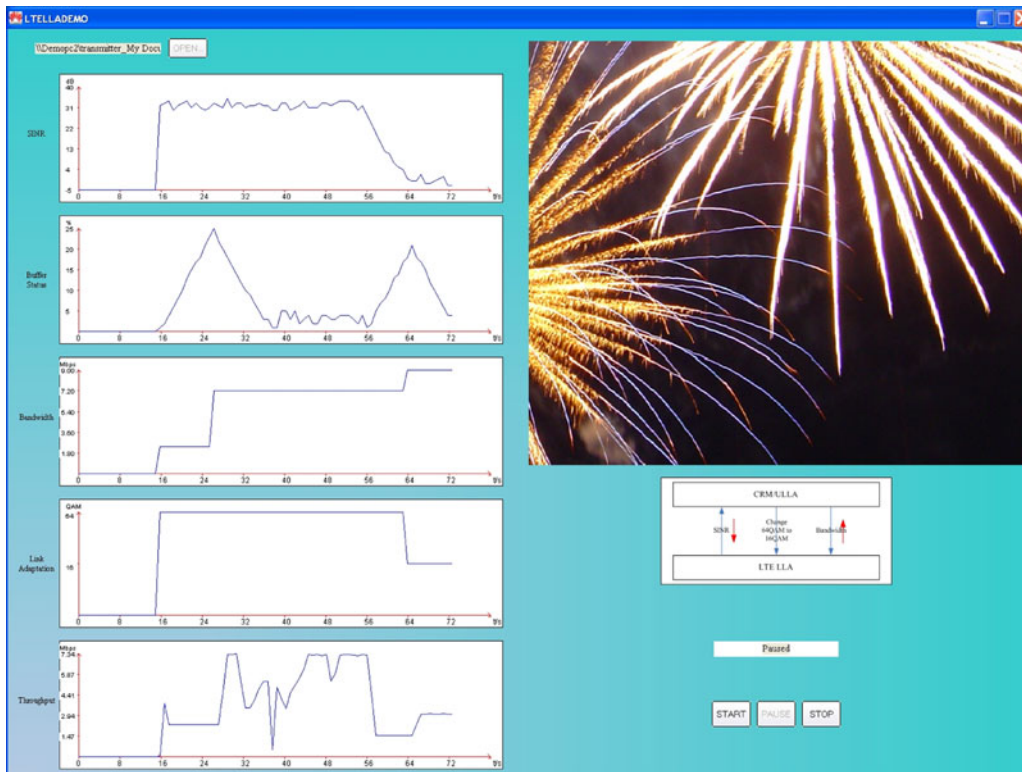

Fig. 11 When the system suffers bad radio environment detected by the low SINR, the CRM performs link adaptation and increases bandwidth allocation as compensation

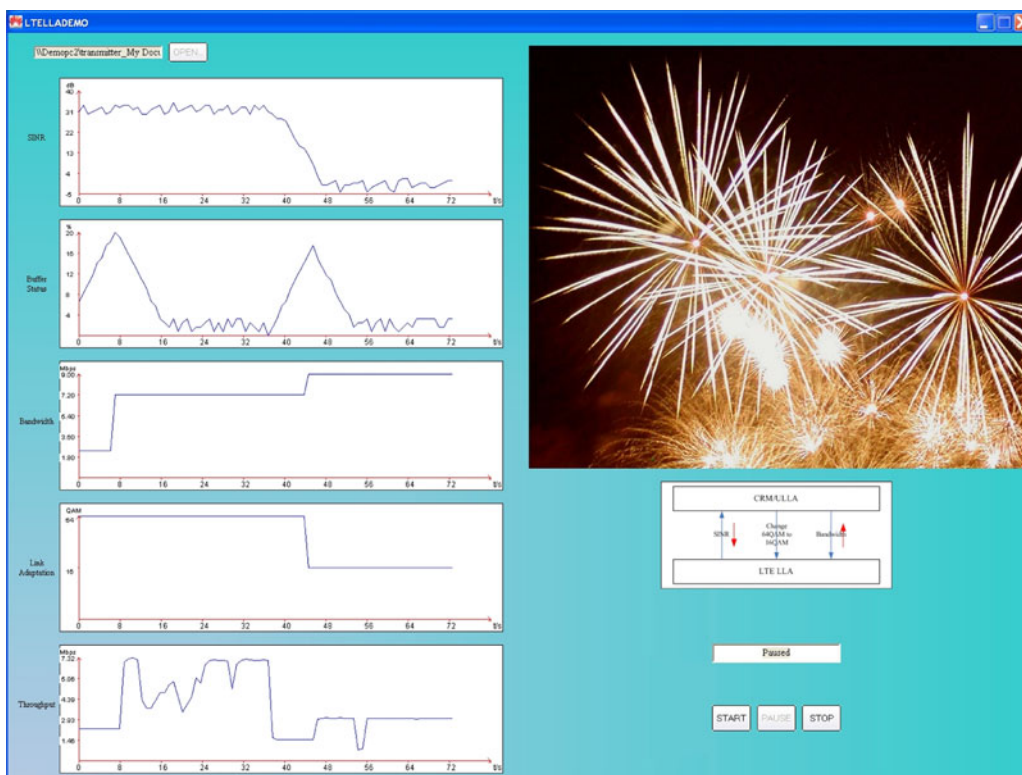

Fig. 12 Buffer size goes back to normal status and system throughput is acceptable for the streaming service



Fig. 13 Radio condition has improved and CRM increases modulation order and decreases bandwidth to ensure efficient use of radio resource

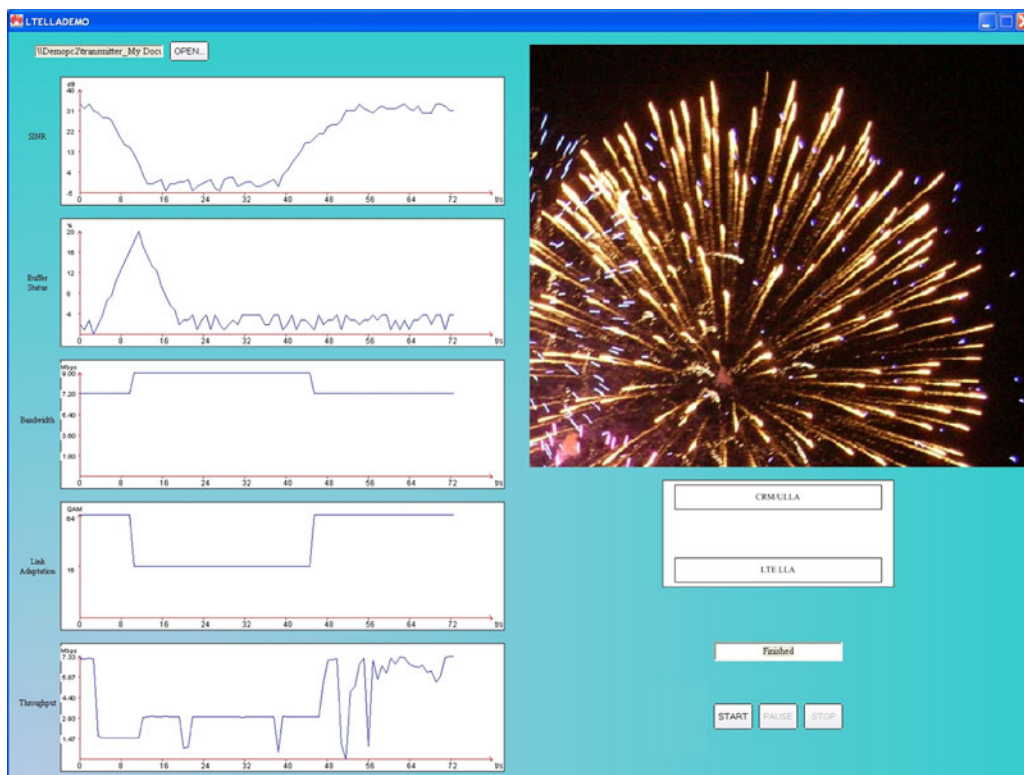

Fig. 14 CRM/ULLA continues with tracing system status and changes parameters accordingly

layer control functions (e.g., policies) and also handling directly some of traditional RRM tasks. Moreover legacy RRM functionality exists and can be controlled by the CRM. This shows that migration towards new CRM/ULLA type of approach does not need to be ‘clean stable’ approach. One can choose more gradual integration path and two different architectures can even co-exist and cooperate when properly designed.

In addition the article has shown how a radio environmental map can be implemented in a cellular network to provide the CRM with necessary information about the environment in order to assist the RRM.

In this demonstration, ULLA/CRM have shown their capability to react upon the changes of system and radio link status and tune system parameters to achieve efficient resource usage. More advanced control algorithms can be added into CRM, which will be for the further study.

Acknowledgments The work reported in this contribution was carried out with financial support from the European Commission under the ARAGORN project (grant number ICT-216856) and the FARAMIR project (grant number ICT-248351), which we gratefully acknowledge.

References

1. J. Mitola, Cognitive radio: an integrated agent architecture for software defined radio. PhD thesis, KTH, Royal Institute of Technology, 2000.
2. R. W. Thomas, D. H. Friend, L. A. DaSilva, and A. B. MacKenzie, Cognitive networks: adaptation and learning to achieve end-to-end performance objectives, *IEEE Communications Magazine*, Vol. 44, No. 22, pp. 51–57, 2006.
3. D. Raychaudhuri, N. B. Mandayam, J. B. Evans, B. J. Ewy, S. Seshan, and P. Steenkiste, CogNet: an architectural foundation for experimental cognitive radio networks within the future internet. In: *1st ACM/IEEE International Workshop on Mobility in the Evolving Internet Architecture (MobiArch 2006)*, pp. 11–16, Dec 2006.
4. K. E. Nolan, P. Sutton, and L. Doyle, An encapsulation for reasoning, learning, knowledge representation, and reconfiguration cognitive radio elements. In: *1st International Conference on Cognitive Radio Oriented Wireless Networks and Communications (CROWNCOM 2006)*, pp. 1–5, June 2006.
5. M. Petrova, P. Mähönen, J. Riihijärvi, and M. Wellens, Cognitive wireless networks: your network just became a teenager. In: *Poster in IEEE INFOCOM*, Barcelona, April 2006.
6. M. Petrova and P. Mähönen, Cognitive resource manager. In F. Fittzek and M. Katz, editors. *Cognitive Wireless Networks*, Springer, Heidelberg, pp. 397–422, 2007.
7. M. Dillinger, K. Madani, and N. Alonistioti, editors, *Software Defined Radio: Architectures, Systems and Functions*, Wiley, New York, 2003.
8. Y. Zhao, B. Le, and J. H. Reed, Network support: the radio environment map. In: B. A. Fette, editor. *Cognitive Radio Technology*, Elsevier, Burlington, pp. 337–363, 2006.
9. <http://www.ict-aragorn.eu/>. Accessed 5 Feb 2011.
10. ARAGORN Project deliverable D5.3, Final Prototype Description. http://www.ict-aragorn.eu/fileadmin/user_upload/deliverables/ARAGORN_D53_v1.00.pdf. Accessed 30 May 2011.
11. ARAGORN Project deliverable D3.3, Final System Architecture. http://www.ict-aragorn.eu/fileadmin/user_upload/deliverables/Aragorn_D33.pdf. Accessed 5 May 2011.
12. <http://www.ict-faramir.eu/>. Accessed 5 Feb 2011.
13. M. Sooriyabandara, et al., Unified link layer API: a generic and open API to manage wireless media access, *Computer Communications*, Vol. 31, No. 5, pp. 962–979, 2008.
14. GOLLUM Project deliverable D2.4, Final architecture and API. http://www.ist-gollum.org/fileadmin/user_upload/deliverables/Gollum_D24-Final-architecture-and-API.pdf. Accessed 30 May 2011.
15. ARAGORN Project deliverable D2.4, Final Specification of Generic Interfaces. http://www.ict-aragorn.eu/fileadmin/user_upload/deliverables/Aragorn_D24.pdf. Accessed 30 May 2011.
16. V. Atanasovski et al., Cognitive radio for home networking. In: *IEEE Symposium on New Frontiers in Dynamic Spectrum Access Networks (DySPAN 2010)*, demo paper, Singapore, pp. 1–2, Oct 2010.
17. C. Rohrig and F. Kunemund, Estimation of position and orientation of mobile systems in a wireless LAN. In: *Proceedings of the 46th IEEE Conference on Decision and Control*, New Orleans, LA., pp. 4932–4937, Dec 12–14, 2007.
18. R. K. Martin and R. Thomas, Algorithms and bounds for estimating location, directionality, and environmental parameters of primary spectrum users, *IEEE Transactions on Wireless Communications*, Vol. 8, No. 11, pp. 5692–5701, 2009.
19. V. Atanasovski et al., Constructing radio environment maps with heterogeneous spectrum sensors. In: *Proceedings of the 2011 IEEE International Dynamic Spectrum Access Networks Symposium (DySPAN 2011)*, Aachen, Germany, May 3–6, 2011.
20. 3GPP, “Evolved Universal Terrestrial Radio Access (E-UTRA), Long Term Evolution (LTE) physical layer, General description”, 36.201, V8.3.0.
21. 3GPP, “Evolved Universal Terrestrial Radio Access (E-UTRA) and Evolved Universal Terrestrial Radio Access Network (E-UTRAN), Overall description, Stage 2”, 36.300, V9.0.0.
22. Y. Bai, J. Zhou, and L. Chen, Hybrid spectrum usage for over-laying LTE macrocell and femtocell. *IEEE Global Telecommunications Conference (GLOBECOM 2009)*, pp. 1–6, Nov–Dec 2009.
23. 3GPP, “Evolved Universal Terrestrial Radio Access, User Equipment (UE) transmission and reception”, 36.101, v.8.0.0.
24. 3GPP, “Evolved Universal Terrestrial Radio Access, Base Stations (BS) transmission and reception”, 36.104, v.8.0.0.

Author Biographies

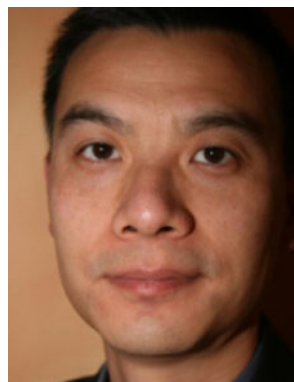

Tao Cai received his B.Sc. degree in physics from Fudan University, China in 1990 and his Ph.D. degree in Electrical Engineering from Beijing University of Posts and Telecoms in 1999. From 1999 to 2001, he worked at Ericsson Research Beijing Lab, where he focused on RRM aspects for WCDMA/HSDPA system. From 2001 to 2002, he was Research Associate with Radio Communication Systems of KTH, Royal Institute of Technology in Sweden.

Since August 2002, he has worked for the Sweden R&D centre of Huawei Technologies as senior research engineer, senior system

architect and expert in cognitive radio networks. He has worked on various research projects including EU Frame Program 7 (FP7) projects. His research interests include RRM algorithm design/performance optimization, self-organizing networks and cognitive radio as applied to next generation mobile network technologies.



Jaap van de Beek is a principal research engineer with Huawei Technologies Sweden. He holds a M.Sc. degree in applied mathematics from the University of Twente, The Netherlands, and a Ph.D. degree in Signal Processing from Lulea University, Sweden. Since 1994 he has been in the telecommunications industry. Prior to joining Huawei in 2002 he worked for Telia Research, Nokia Networks, and was an assistant professor with Lund

University, his work concentrating on the physical layer of radio access networks, on topics ranging from signal design, modulation and coding to synchronization and receiver optimization. He is a recipient of the 2010 IEEE ComSoc Heinrich Hertz award for best communications letter. Currently he is engaged in collaborative European research through the EU's Seventh Framework Programme. His research interests include interference mitigation strategies in cellular networks, modulation techniques for the MIMO channel, along with opportunistic access of the radio spectrum in cognitive systems.



Jad Nasreddine is currently working as a senior researcher at the Institute for Networked Systems at RWTH Aachen University. Between 2005 and 2010 he was working as Post-doctoral researcher at Telecom Bretagne, BarcelonaTech (UPC) and RWTH Aachen University. He received his Ph.D. degree in March 2005 from the University of Rennes I and his engineering diploma in computer science and telecommunications in 2001 from the Lebanese university.

During his Ph.D., he was working as research assistant at Telecom Bretagne. Dr. Nasreddine has participated in national and industrial projects in France, Spain and Germany as well as IEEE P1900.4 working group. He has also managed and participated in several

European projects. He is an IEEE member and has served as chair, TPC and reviewer for several conferences and journals. His research interests include cognitive and composite networks, spectrum and radio resource management, Femtocells and propagation models.

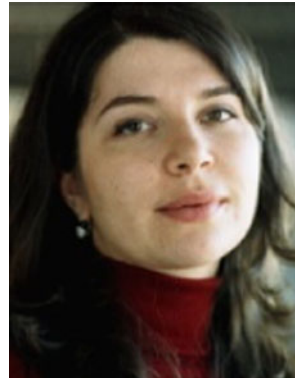

Marina Petrova is with the Faculty of Electrical Engineering and Information Technology at RWTH Aachen University. She is currently a chief research scientist in the Institute for Network Systems. Her research interests are focused on cognitive wireless networks, cognitive radios and adaptive wireless systems technologies. Dr. Petrova has participated in several international cooperative projects and industry projects in the field of wireless

communications and cognitive radios. Moreover, she is also heavily involved in research activities towards prototype implementation of cognitive resource management solutions for cognitive radios. Dr. Petrova holds a degree in engineering and telecommunications from University Ss. Cyril and Methodius, Skopje and a Ph.D. from RWTH Aachen University, Germany. She has served in technical program committees of numerous IEEE conferences and workshops. This year she served as a TPC-co Chair of DySPAN 2011.



Petri Mähönen is currently a full professor and head of the Institute for Networked Systems at RWTH Aachen University. Before joining to the faculty of RWTH in 2002 he was a professor and research director at the Centre for Wireless Communications in Finland. He has extensive experience in mobile communications research both in radio network technologies and applications domain. He is also one of the research area coordinators of UMIC Research

Centre at RWTH Aachen, which is one of German research excellence clusters. Dr. Mähönen has acted as a principal investigator for both ARAGORN and FARAMIR research projects. His current research focuses on novel mobile systems applications and architectures, cognitive radio technologies, low-cost low-power communications, and wireless sensor networks.